

# Custom Track Service Handbook

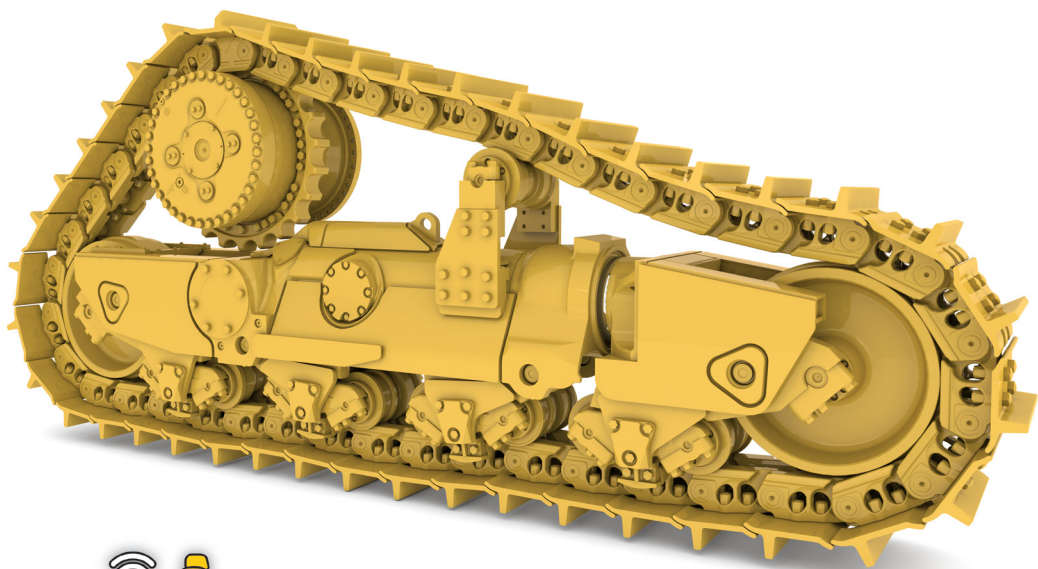

17th Edition

**CATERPILLAR®**

**NOTE:**

**Blue text throughout this PDF will link you to the page indicated.**

**To navigate this PDF in Adobe Reader: set the "Back" and "Previous" buttons on your tool bar by following these steps:**

1. Go to "View" on Menu bar at the top
2. Click Show/Hide Tool Bar Items
3. Click Page Navigation
4. Click Show All Navigation Tools

**Then you will see small arrow buttons to go back and forth to previous pages**

---

# Section

Page

---

Last Updated: >mofi 2015

<b>Introduction</b> .....	<b>3</b>
<b>General Information</b> .....	<b>5</b>
Measurement Tools .....	5
Controllable Variables .....	10
Partially Controllable Variables .....	22
Component Discussions .....	23
Links .....	24
Former Link Service Limits .....	30
Sealed & Lubricated Track Pins & Bushings .....	31
Sealed Track Pin & Bushings .....	39
Shoes .....	44
Idlers .....	49
Carrier Rollers .....	53
Track Rollers .....	56
Sprockets .....	60
Guards .....	64
<b>Management &amp; Merchandising</b> .....	<b>65</b>
Track Management .....	65
Wear Limits .....	65
Track Seal Replacement Recommendations .....	67
CTS Inspection Report .....	69
Calculations .....	71
Using CTS Reports To Manage Undercarriage .....	72
CTS on the Personal Computer .....	81
Competitive Machine Undercarriage Conversion .....	82
<b>Elevated Sprocket Machines</b> .....	<b>85</b>
Introduction .....	85
D4H, D5M, D5N - 6.75 IN. (171.5 mm) .....	107
D5H, D6M, D6N - 7.50 in (190 mm) .....	131
D6H, D6R, D6T - 8.00 in. (203.2 mm) .....	155
D7H, D7R, 572R - 8.50 in. (215.9 mm) .....	184
D8N, D8R, D8T - 8.58 in. (218 mm) .....	209
D8L, D8N, D8R, D8T, 578, 583R, 583T, 587R, 587T, PL83, PL87 - 8.50 in. (215.9 mm) .....	210
D9N, D9R, D9T - 9.45 in. (240 mm) .....	227
D9L, 589 - 9.00 in. (228.6 mm) .....	237
D10N, D10R, D10T - 10.25 in. (260.4 mm) .....	245
D10 - 10.25 in. (260.4 mm) .....	255
D11N, D11R, D11T - 12.50 in. (317.5 mm) .....	263
<b>Low Sprocket Machines</b> .....	<b>283</b>
Introduction .....	283
D3C, D3G, D3K, D4C, D4G, D4K - 6.91 in. (175.5 mm) .....	299
D3, 931, 933, 935, D4B, D4C, D4G - 6.125 in. (155.6 mm) .....	310
D4, 941 - 6.75 in. (171.5 mm) .....	327
D5K - 7.50 in. (190 mm) .....	342
D5K - 6.75 in. (171.5 mm) .....	343
D5G, D5C, 939 - 6.75 in. (171.5 mm) .....	357

D5, 955, 951, 561 - 6.91 in. (175.5 mm).....	378
D6K, D6K2, PL61 - 7.50 in. (190 mm).....	400
D6, 955 - 8.00 in. (203.2 mm) .....	412
D7E - 8.50 in. (215.9 mm) .....	445
D7, 977 - 8.50 in. (215.9 mm) .....	454
D8, 583, 983 - 9.00 in. (228.6 mm) .....	480
D9, 594 - 10.25 in. (260.4 mm) .....	492
<b>Hydrostatic Loaders.....</b>	<b>503</b>
Introduction.....	503
943 - 6.75 in. (171.5 mm) .....	512
953 - 7.50 in. (190 mm) .....	520
953 - 6.91 in. (175.5 mm) .....	538
963 - 8.00 in. (203.2 mm) .....	549
973 - 8.50 in. (215.9 mm) .....	570
<b>Excavators &amp; Forest Machines .....</b>	<b>589</b>
Introduction.....	589
304, 304.5, 305, 305.5, 306 - 5.31 in. (135 mm) .....	597
307, 308 - 6.06 in. (154 mm), 5.31 in. (135 mm) .....	606
312B, 312C - 6.75 in. (171.5 mm) .....	617
311, 312, 313, 314 - 6.75 in. (171.5 mm).....	618
313D2 LGP, 315, 316, 317, 318, 319, 320, 320 FM, 321, 322, 322 FM, 323, 324, 326, 1090 - 7.50 in. (190 mm).....	628
320 FM, TK711, 1090 - 7.50 in. (190 mm) .....	629
320S, 320 FM, 322 FM, 323S, 324 FM, 325, 329, 511, TK711, 1090 - 8.00 in. (203.2 mm).....	650
324 FM, 325 FM, 521, 522, 1190, 1390, TK721, TK722, TK741 - 8.00 in. (203.2 mm).....	651
328, 330, 330 FM, 336, 340, 532, 541, 1290, 1390, TK732 - 8.50 in. (215.9 mm) .....	667
325 FM, 330 FM, 345, 349, 551, 552, 568, TK751, TK752 - 8.50 in. (215.9 mm) .....	680
345FM, 350 - 9.00 in. (228.6 mm).....	693
365, 374 - 10.25 in. (260.4 mm) .....	701
375, 385, 390, 5080, 5090 - 10.25 in. (260.4 mm) .....	702
5110 - 10.25 in. (260.4 mm) .....	715
5130 - 12.50 in. (317.5 mm) .....	723
5230 - 14.90 in. (378.5 mm) .....	733
<b>Paving Products/Drive Belts .....</b>	<b>739</b>
Introduction.....	739
PM465 - 5.31 in. (135 mm).....	740
AP650, AP1050, BG225, BG245 — 6.125 in. (155.6 mm).....	748
SF250B, TR225B, PR450, SF350 — 6.125 in. (155.6 mm) .....	759
PR750, PR1000, SF500, SF550, TR500 — 6.75 in. (171.5 mm) .....	766
PM565 — 6.75 in. (171.5 mm).....	772



Edition Seventeen is a comprehensive update to the CTS Handbook in conjunction with the release of CTSi 1.0. The smaller handbook size is a result of dealer feedback and now fits easily inside the UWI tool kit. Updates were made to the General Information and the Management and Merchandising sections. The Introduction sections of each product type were also updated.

Some of the changes you will notice include:

- Undercarriage Codes are no longer utilized with the new CTSi computer program. Instead, the individual Wear Chart number applicable to the model's undercarriage component is located beneath each chart. UC codes are no longer listed at the front of each product type's introduction section of the handbook.
- The machine models and applicable wear charts are up-to-date.
- Classic undercarriage wear charts are now incorporated into the various product type sections.
- The 200 series and 'E' series Excavators have been removed from the CTS Handbook. A separate e-book in PDF format, Media No. PEKP9414, is available for download via the Cat Media Information Center (CMIC). These models will still reside in the CTSi computer program.
- Information regarding the new CTS Reports formats that can now be generated in CTSi, including 'Simple' and 'Detailed' formats (Percent Worn report also includes a 'Graph' format).



## 6V-9413 CTS Tool Kit

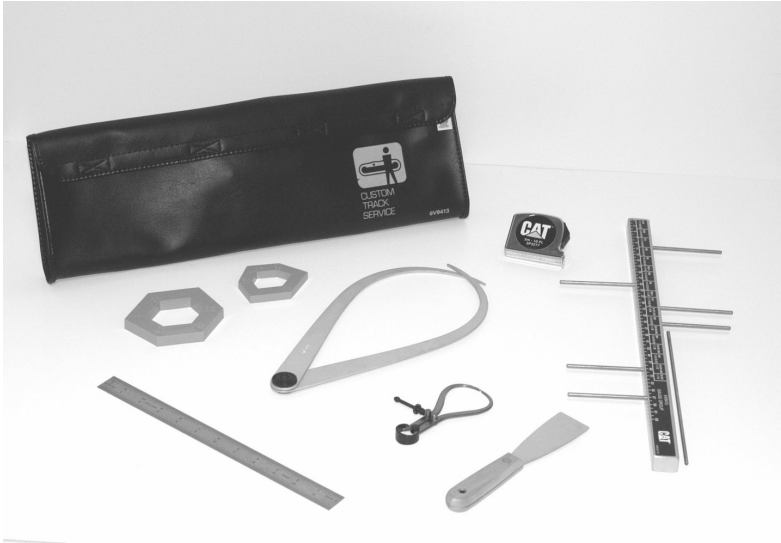

Part Number	Description	Use
6V-9413	CTS Tool Kit	Complete Set of Tools
6V-7784	CTS Pouch	Carrying Tools
8H-8580	Scraper	Cleaning U/C Components
5P-3920	12 in. Steel Rule	With Caliper and Depth Gauge
4S-9404	12 in. Caliper	Bushing O.D.
8T-7790	6 in. Caliper	D11N - D11T Bushing O.D.
4S-9405	12 in. Caliper	Roller Diameter
5P-3277	12 ft. tape	Track Pitch, D4H-D11T Sprockets
6V-9410 <sup>(1)</sup>	Depth Gauge	Multi-Purpose All Models

1 Replacement parts for the 6V-9410 Multi-Purpose Depth Gauge:  
 6V-9409 — 10 in. Probe  
 6V-9408 — 4 in. Probe

# Measurement Tools

## 423-0478 Ultrasonic Wear Indicator IV Group



Part Number	Description
<b>423-0478</b>	<b>Ultrasonic Wear Indicator IV Group with case and other CTS tools, includes:</b>
415-4055	Ultrasonic Wear Indicator IV Group
8H-8580	Scraper
5P-3920	12" Steel Ruler
4S-9405	12" Caliper
5P-3277	10" Tape Measure
423-0483	Depth Gauge
9U-7981	Ultrasonic Couplant (2)
<b>415-4055</b>	<b>Ultrasonic Wear Indicator IV Group with case, includes:</b>
415-4051	Ultrasonic Wear Indicator IV
415-4052	Ultrasonic Probe
415-4053	Soft Case
415-4054	Foam Assembly
267-6532	Towel (19)
6V-7145	Case
<b>415-4051</b>	<b>Ultrasonic Wear Indicator IV, includes:</b>
425-6888	Serial Cable
370-8059	USB to Serial Adapter
	Rubber Connector Plugs (4)
NEHS1164	Tool Operating Manual



**Former Ultrasonic Wear Indicator III Group**



<b>Part Number</b>	<b>Description</b>
	Ultrasonic Wear Indicator III Group
	Ultrasonic Wear Indicator III
415-4052	Ultrasonic Probe
9U-7981	Couplant
4C-5490	Couplant Holder
6V-7145	Case (without foam insert)
4C-4772	Foam Insert
4C-3024	Battery Charger (120 or 230 volts 50/60 Hertz)
267-6532	Paper Towels (19 towels)
1U-7445	Rechargeable Batteries, Nickel Cadmium (AA)
9U-6175	Ultrasonic Wear Indicator Soft Protective Case
1U-9533	Non rechargeable Batteries, Alkaline (AA)
4C-5488	Cable Assembly, 9 pin female connector, for personal computer
4C-5489	Cable Assembly, 25 pin female connector, for personal computer
370-8059	Adapter Kit — USB to Serial Port (for computers with no serial port)
NEHS0730	Tool Operating Manual

**NOTE**

A 12-volt automotive power supply adapter (6 volts DC) and an earphone are available through many electronic supply retailers.

## Ultrasonic Wear Indicator

---

The new Ultrasonic Wear Indicator IV for measuring undercarriage components is now available. It replaces the Ultrasonic Wear Indicator III.

The Ultrasonic Wear Indicator IV will electronically download data to the new CTSi version 1.0 or greater software. There are three options for current users of CTS v5.7:

- The Ultrasonic Wear Indicator IV can be used to measure undercarriage components, and the measurements can be manually entered into CTS v5.7.
- CTSi v1.0 will be available in late July. Users of this version can load machines that already exist in their CTS v5.7 data. This option is best for current CTS v5.7 users who need to purchase a new tool because they do not have a working UWI tool.
- CTSi v1.1 will be available in October 2013. Users of this version will have complete web access, including the capability to add additional machines. This option is best for new CTSi users who need the ability to add new machines and who need a new UWI tool. This option is also recommended for CTS v5.7 users who desire to upgrade to the new CTSi functionality.

**Note:** The previous Ultrasonic Wear Indicator III does work in conjunction with the new CTSi v1.0 and v1.1. The Ultrasonic Wear Indicator IV is not required to function with the new CTSi v1.0 and v1.1.

- Smaller size – easier carrying and storage
- Larger display – enhanced readability
- Improved ultrasonic probe – faster inspections
- Multiple inspection modes – greater capability for various inspection needs
- Custom inspection – customized personal inspection sequence
- More memory – increased storage of machines (up to 100)
- Percent worn calculation – immediate feedback of component wear level
- Beeper and lights – visual and audible confirmation when tool is ‘coupled’
- Contrast adjustment – adjustable screen visibility for different lighting conditions

## Ultrasonic Wear Indicator

The Ultrasonic Wear Indicator measures components thickness by sending high frequency sound waves through the material to be measured. The elapsed time between sending and receiving the sound waves allows the tool to determine thickness.

This electronic CTS tool has the following key features and benefits:

- Ultrasonic wave emitting probe
  - Reduces time spent cleaning parts (especially bushings and shoes).
  - Eliminates measurement errors due to dirt packing around parts.
  - Measures bushings after turning.
  - Eliminates errors due to measurement technique differences among inspectors.
  - Measures idler center flange wear.
- Memory
  - Reduces on-site measurement recording.
  - Stores inspections for 100 machines
  - Downloads to CTS computer program for automatic percent worn and projected life calculations.
  - Uploads previous inspections from CTS computer program to improve speed and quality.
- Language capability
  - English, French, German, Portuguese, Spanish.
- Earphone connector
  - Allows users to hear "Coupled" beeping indicator.
- Backlight feature
  - Allows users to see the display in poor lighting conditions.

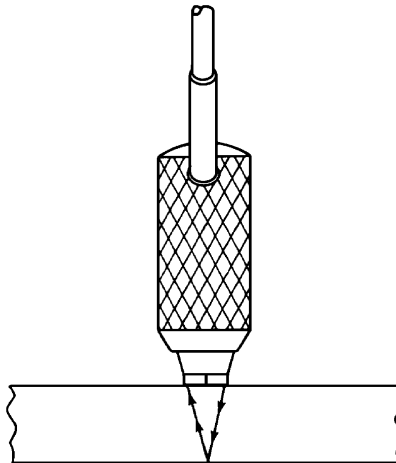

# Controllable Variables

---

## Variables That Affect Undercarriage Life

The variables that determine undercarriage system life and wear balance between components can be divided into three major groupings. The first are those that are controllable. Controllable variables would include track tension, shoe width, machine balance, and alignment of components.

The second major group, non-controllable variables, are 100 percent determined by the underfoot conditions. They include impact, abrasiveness, packing, moisture, terrain and even machine application (what the machine is doing).

The third major group is partially controllable variables. These mainly involve machine operator controllable events or "habits", including working the load always on one side of the machine.

A thorough knowledge of each of the elements of all these three major groups is essential if the CTS expert is going to be able to not only explain "what has happened", but also "what could be expected to happen," especially as any of these variables were to change. Awareness of the relative interplay between these variables on the final wear or structural life of specific components, and even on the system is so important that their discussion has been placed at the front of this book. To use the rest of the book before understanding these would be counterproductive.

## Controllable Variables

Controllable variables that affect undercarriage life can have a major economic effect on the operation of undercarriage systems. The three significant controllable variables include track adjustment (tension/sag), track shoe width, and alignment.

Shoe width can cause a wide range of problems, including track seal and lubricant integrity; link cracking, roller flange wear, and bushing wear. Shoe width is controllable because the user, with your advice, chooses which shoe to order

Alignment, the third and least critical controllable variable is discussed here because, particularly on low sprocket machines, it is wrongly blamed as a cause for many symptoms. It is beneficial to know how misalignment does and does not affect wear patterns so you can better identify the real cause, controllable or not. A short discussion on track-excited vibration is also placed in this area even though it is only controllable at a machine design time.

## Track Adjustment

Tight track can drastically affect bushing life (increasing wear rate as much as three times) and is listed frequently as a "cause" or "accelerator" under the wear and structural problems section for many components. Reference the separate machine sections for instructions on how to measure and adjust track sag.

Shoe width can cause a wide range of problems, including track seal and lubricant integrity, link cracking, roller flange wear, and bushing wear. Shoe width is controllable because the user, with your advice, chooses which shoe to order.

Use the chart [on, page 44](#) to help choose the right shoe based on the factors described below.

---

### Factors Affecting Machine Production

---

#### Flotation

Choose a shoe width that provides adequate flotation, but not more than is needed. The narrowest shoe that provides adequate flotation will prevent the machine from sinking into the underfoot material.

#### Penetration-Traction

Additional shoe width does not provide greater penetration or traction and consequently does not increase production, assuming adequate flotation.

#### Maneuverability

Wide shoes increase turning resistance, making the machine harder to handle and decreasing productivity.

#### Versatility

Increased shoe width improves machine versatility by allowing it to work in both “hard” and “softer” underfoot conditions without losing flotation. Unfortunately, wider shoes accelerate wear and structural damage.

---

### Undercarriage System Wear and Structural Life Factors

---

#### Shoe Wear Life

Wider shoes do not improve wear life. The extra wear material provided by wider grousers gives little extra life. The largest variable affecting shoe wear life is slippage.

#### Shoe Structural Life

Bending stress on shoes increases proportionately with width. Cracking, bending, and hardware loosening increase as shoe width increases.

Basic Rule of Thumb: Always specify the narrowest shoe possible that will provide adequate flotation and traction without excessive track slippage.

#### Link-Roller-Idler Wear Life

Wear rates increase on link rail sides, roller flanges and idler flanges as shoe width increases because of increased interference.

#### Pin and Bushing Wear Life

External bushing wear rate on Sealed and Sealed and Lubricated Track and internal wear rate on Sealed Track increases as shoe width increases. This is due to the increased loads, weight and twisting.

#### Pin and Bushing Structural Life

Too wide shoes in high impact or steep terrain can cause pins and bushings to loosen in the link bores, resulting in dry joints. Loss of pin and bushing retention prevents successful pin and bushing turns.

## Controllable Variables – Shoe Width

---

### Undercarriage System Wear and Structural Life Factors (Cont'd.)

---

The following chart shows the effect of track link assembly bending stresses as shoe width increases.



---

### Sealed and Lubricated Track Joint Life

---

The most costly effect of too wide shoes is the loss of lubricant and seal life resulting in premature dry joints. The wider the shoe, plus the higher the impact, the greater the chance of a pressed track joint "opening up," allowing loss of lubricant. The loss of lubricant occurs when the bushing slides back and forth along the pin. The clearance between the links created by this "opening up" is called end play. End play can only be eliminated by pressing the components tight when track press work is performed. For maximum lubricant and seal life the machine should be equipped with the narrowest possible shoes which will provide adequate flotation.

Proper roller frame, idler and sprocket alignment is important to avoid accelerated, unbalanced wear on moving undercarriage components (roller tread and flanges, link rails and rail sides and sprocket sides).

As a general rule any wear pattern differences between left and right, inner and outer, or front and rear may be due to improper alignment of one or more parts of the roller frame, idlers or sprockets.

Following is a description of the more common types of alignment problems, their cause, effect, and the steps required to correct the cause:

---

### NOTE

The D9R (SN 7TL1212-up and 8BL1422-up). D10R (SN 3KR1331-up) and D11R (SN 9TR202-up and 9XR154-up) have unique Track Roller Frame alignment to increase link and roller life. This is detailed in Service Magazine SEPD0469.

---

## Roller Frame (including diagonal brace)

---

### Toe-In and/or Toe-Out

When viewed from the top, the roller frame is not parallel to the center line of the tractor.

**Cause:** temporarily (during load only) or permanently bent diagonal brace or roller frame.

**Effect:** unbalanced wear when comparing inboard versus outboard roller and idler flanges and rail sides — rollers worsen from rear to front

**Remedy:** straighten diagonal braces and repair mounting bearings.

---

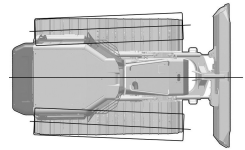

### Tilt

When viewed from front or rear the roller frame tilts toward or away from tractor.

**Cause:** bent diagonal brace, broken mountings or bearings

**Effect:** unbalanced wear when comparing inboard versus outboard roller, idler, link treads and flanges — unbalance from front to rear on rollers.

**REMEDY:** straighten diagonal brace and/or repair mountings

---



### Bow

Similar to toe-in and toe-out, but roller frame is bent and curves in or out with respect to tractor.

**Cause:** bent roller frame

**Effect:** similar to toe-in and toe-out except rear rollers are not affected

**REMEDY:** straighten roller frame

---

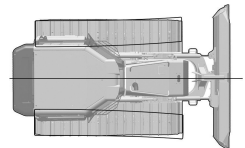

## Controllable Variables – Alignment

---

### Roller Frame(including diagonal brace) (Cont'd.)

---

#### Twist

When viewed from the front, the roller frame is twisted, with the front end of the roller frame tilted out.

**Cause:** roller frame twisted around a horizontal axis parallel to the tractor

**Effect:** similar to effect of tilt except that rear rollers should not be affected

**Remedy:** straighten roller frame

---

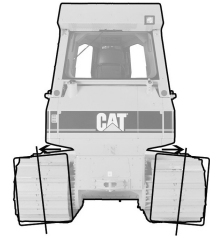

### Idler Mounting

---

#### Toe-in or Toe-out

When viewed from top, idler is not parallel to center line of roller frame

**Cause:** bent idler support box sections or bent idler yoke

**Effect:** wears inner rail sides and idler flanges most — may affect wear on front roller flanges

**Remedy:** straighten idler support box sections or yoke

---

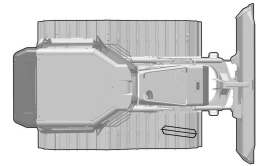

#### Idler Height

Idler height is the distance between the bottom tread surface of the idler and the bottom tread surface of the adjacent track roller. The idler should always be higher than the track roller.

**Cause:** insufficient or excessive idler height, due to incorrect original adjustment, track roller wear, or deterioration or loss of bogie pads

**Effect:** if idler height is too low, excessive machine vibration. If idler height is too high, poor dozing control, particularly during finish dozing operations

**Remedy:** use shims to set the correct idler height

---

#### Lateral Displacement

When viewed from top, idler is parallel to, but moved toward or away with respect to the tractor and roller frame.

**Cause:** improper shimming

**Effect:** wears idler flanges, inner rail sides, and adjacent track roller(s)

**Remedy:** correct shimming

---

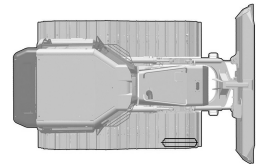

#### Twist — Tilt

When viewed from front, idler tilts out of vertical plane.

**Cause:** bent idler support box frame

**Effect:** same as toe-in or toe-out

**Remedy:** same as toe-in or toe-out

---

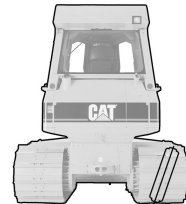



### Sprocket

---

#### Toe-in, Toe-out

When viewed from the top, sprocket not parallel to center line of roller frame.

**Cause:** sprocket shaft bent

**Effect:** wears inner link sides and segments sides

**Remedy:** straighten or replace sprocket shaft

---

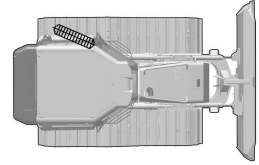

#### Twist

When viewed from rear, sprocket is leaned or tilted in or out with respect to the roller frame

**Cause:** sprocket shaft bent up or down

**Effect:** same as toe-in, toe-out

**Remedy:** same as toe-in, toe-out

---

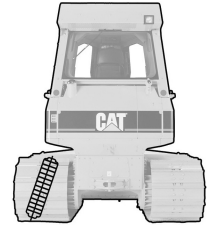

#### Lateral Displacement

When viewed from top or rear, sprocket is parallel to but moved in or out with respect to tractor and roller frame

**Cause:** sprocket not pressed proper distance onto shaft

**Effect:** inboard or outboard sprocket sides and rail insides worn, may affect rear roller flanges

**Remedy:** re-position sprocket on shaft

---

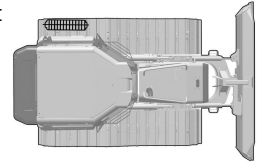

### General Statements about Alignment Problems, Symptoms, Causes, Effects and Remedies:

1. The larger and heavier the machine and the more severe the impact, the greater likelihood of alignment problems.
2. Alignment problems of roller frame, idler, and sprocket will affect all **links** the same.
3. Alignment problems of roller frame, idler, and sprocket will affect **track rollers** unequally (front to rear rollers, inner to outer flanges, and inner and outer treads).
4. Horizontal straightness of roller frame will not affect links but will affect front and/or rear roller treads compared to center.
5. Snaky track will not cause near the degree of damage as caused by misalignment.
6. Carrier roller wear can be used as a visual indicator of roller frame alignment.
7. Some alignment problems are temporary (caused by working loads). If both sides of a machine have the same misalignment type wear patterns, the cause may be flexing of the track roller frames due to working loads.
8. If misalignment is suspected, it is important to completely correct it before installing new under-carriage components.
9. Tight track increases the effect of all types of alignment problems because it increases the loads between the interfering components.

# Vibration

---

## Track-Excited Vibration

Track-excited vibration is the most widely encountered vibration on track-type machines. As the machine moves, each link, as a part of an endless rail, makes contact with two curved surfaces, idlers and track rollers.

Contact between the idlers and the links causes wear in the center of the link. Contact between the track rollers and the links causes wear on the ends of the links where they overlap with the adjacent link. As a result of this wear, a scallop pattern is formed on the surface of each track link. [See, page 25](#)

This type of link wear can be accelerated by abrasiveness and moisture content of the soil, machine weight, travel speed, and underfoot conditions. It is sometimes possible that track-excited vibration will go unnoticed on rough terrain, yet be apparent when the machine is working on a smooth surface.

The depth of scallop and the scallop-roller spacing determine how smoothly the machine travels. If the spacing of the track roller and scallops are uneven, so that some of the rollers are on the high points of the link while others are over the low points, the machine will move across the scallops more smoothly. However, if the spacing is the same, the rollers will rise and fall in unison with each scallop as they pass over the links, thus creating vibration.

The relationship between machine speed and the depth of the scallops also affects the vibration. The speed of the machine determines the frequency of the vibration while the depth of the scallops controls the amplitude of the vibration. In addition, natural frequencies, which occur in all structures, can respond to the vibration. Because of this response, it is possible for certain parts of a machine, such as the roll-over protection structure, sheet metal components, or, sometimes, the whole machine, to respond to the initial frequency and begin vibrating.

The vibration can be reduced by replacing deteriorated isolation mounts where necessary, replacing any broken or missing fasteners and by generally keeping the machine in good repair. A change in operating speed or technique, or a change of counterweights or attachments may reduce the effect.

## Non-Controllable Variables — Underfoot Conditions

---

There are a number of variables that affect rates and patterns of wear which cannot be controlled. Non-controllable variables include soil and underfoot conditions (abrasion, impact, moisture, packing, corrosion, etc), terrain conditions, and application conditions (what the machine is doing).

---

### Soil & Underfoot Conditions

---

#### Abrasiveness

Abrasiveness of underfoot conditions is the most difficult to accurately measure except by its effect.

#### Abrasiveness Ratings

**High** — Saturated wet soils containing a majority of hard, angular or sharp sand particles.

**Moderate**— Slightly or intermittently damp soils containing a low proportion of hard, angular or sharp particles.

**Low** — Dry soils or rock containing a very low proportion of hard, angular sharp sand or rock chip particles.

The amount of moisture plays a big role in defining abrasiveness. For example, dry, pure quartz sand may be only 1/10 as abrasive as saturated wet, pure quartz sand slurry and only half as abrasive as it is in a damp condition. This is because moisture affects the rate that particles are carried to and stuck to the metal surface being worn. Some abrasive combinations tend to attack the bushing, others the grousers and still others the links and rollers. These differences are difficult to quantify except by actual experience.

Usually, the link is the best component to use for comparing overall relative abrasive effects because it is least subjected to other variables at the same time. The link is commonly used as the base component when comparing wear lives of different components in different abrasive conditions.

#### Impact

Impact of underfoot conditions is determined by weight of the machine and speed is defined under APPLICATION CONDITIONS later in this sub-section.

#### Impact Ratings Description

**High** — Non-penetrable hard surfaces with constant exposure to 6 in. (15 cm) or higher “bumps”.

**Moderate** — Partially penetrable surfaces with constant exposure to smaller bumps.

**Low** — Completely penetrable surfaces which provide full shoe plate support, with low exposure to any height bumps.

The most noticeable affect of impact is on structural problems such as bending, cracking, breaking, chipping, spalling, roll-over, and hardware and pin and bushing retention.

Generally, wear life of larger machines is less affected by variations in impact than smaller machines.

Wide Shoes accentuate the effects of impact conditions. Machines with single grouser shoes are more susceptible to higher impact effects than those with multi-grouser shoes.

#### Packing

Packing describes any condition where underfoot material sticks to or packs between undercarriage components. It has two major effects. First, it can prevent mating parts from properly engaging each other. This can cause interference, high loads and increased wear rates. Examples of this effect include sprocket teeth packing and packing between shoes and bushings, causing the teeth to engage the bushings incorrectly.

## Non-Controllable Variables — Underfoot Conditions

---

### Soil & Underfoot Conditions (Cont'd.)

---

The second major affect of packing is increased wear because abrasive material sticks to wear surfaces. The best example of this is a sand-clay mixture packed around idlers, carrier and track rollers causing constant abrasion when these components contact track links. The result is similar to a grinding or polishing wheel. Parts subjected to this effect are usually polished smooth.

Severe cases of packing will prevent the rollers, particularly carrier rollers, from turning. Then links must slide across roller treads causing flat spots.

Packing materials vary widely and extend far beyond clay and mud that are normally associated with it. The following list of materials can result in one or both of the major effects listed above. Obviously, the moisture content of most of these materials helps determine its stickiness and its compactability. Many underfoot conditions are composed of various combinations of these materials and the effect may be cumulative. Packing materials fall into two categories; (A) those that can usually be extruded or squeezed out from between the parts when wet and (B) those which cannot be extruded with the pressures and opening sizes normally available in track-type machines.

#### Packing Materials

##### A. Extrudable (when wet)

Sanitary Landfill (garbage)  
Silt soils  
Clay soils  
Sandy soils  
Snow and ice  
Metallic ores (taconite)  
Non-metallic ores (gypsum)

##### B. Non-extrudable

Sanitary Landfill (garbage)  
Branches, twigs, and brush  
Stones, rocks, and gravel  
Demolition debris  
Sod-like materials

Generally, the affect of packing cannot be controlled.

Some modifications or component options for use in minimizing the affects of packing are described below. The most common modification to undercarriage components or use of option attachments involves providing Trapezoidal openings for the packing type material to extrude or fall out, thus relieving the pressure. These modifications or attachments should only be used in the presence of extrudable type materials.

1. Trapezoidal Openings in shoes. Caterpillar recommends that track shoes with trapezoidal openings be used in the presence of extrudable material. These shoes are available for most machines. These shoes are not "standard" because, in the absence of packing, they allow underfoot material to enter the system and reduce wear life.
2. Full length track roller guards. These should **not** be used in packing materials except when rocks could enter between the rollers and cause crushing damage. Roller guards are harmful because they tend to keep the packing material in the system.
3. Mud and snow sprockets and segments. These should only be used in the constant presence of soft extrudable packing materials. In any other material they will result in much accelerated external bushing wear due to reduced contact area in the sprocket root.

### Other Environment Variables

---

There are other conditions that may or may not be associated with the soil and underfoot conditions.

#### **Moisture**

The effects of moisture as contributing to abrasiveness and packing have been explained in the previous section. Moisture or water in itself can corrode steel resulting in the loss of wear material.

Moderate amounts of moisture increase the corrosive effects of many other chemicals and compounds; both those found in nature and man made, such as sulfur, salt and fertilizers.

Water in liberal amounts has the beneficial effect of washing abrasive particles away, softening many packing materials to ease their extrusion and finally, diluting some chemical corrosion agents to lessen their effect.

#### **Chemicals**

Corrosive chemicals found in nature plus man-made compounds may have the effect of either eating away at wear material or increase the rate of certain types of cracks. Ironically, most hardened steels are more susceptible to corrosion cracking than softer, unhardened steels. Highly acidic and saline soils can contribute to these effects.

Organic chemicals such as petroleum products can attack rubber load rings and toric rings in rollers and idlers causing them to fail.

#### **Temperature**

High temperatures increase the rate of chemical action. Extremely high temperatures, like those found in slag removal in steel mills, can damage seals and soften hardened steels found in under-carriage parts.

Very low temperatures, near or below -40° F (-40°C), can result in steel brittleness, loss of rubber seal resiliency, and reduction in the needed lubricant flow in Sealed and Lubricated Track, roller and idlers.

# Non-Controllable Variables — Underfoot Conditions

---

## Other Environment Variables (Cont'd.)

---

### Terrain Conditions

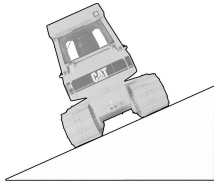

#### Working on Sidehill

Shifts weight balance to the downhill side of the machine. This increases the wear rate on components on the downhill side of the machine. It also increases wear on rail sides, roller and idler flanges, bushing ends, and grouser ends.

---

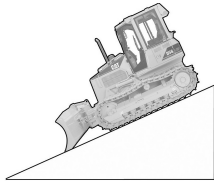

#### Working Downhill

Shifts weight balance forward causing relatively high wear on front track rollers and idlers and on the reverse drive side of the sprocket and bushing.

---

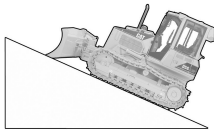

#### Working Uphill

Shifts weight balance to the rear causing relatively higher wear on rear track rollers and idlers and on the forward drive side of the sprocket and bushing.

---



#### Working on a Crown

The side of components that is nearer the center of the machine carries heavier loads. This results in increased wear on the inside wear surface of links, rollers, idler treads and grouser ends. In extreme cases, the inner bushing-to-sprocket contact surfaces also may experience greater wear.

---

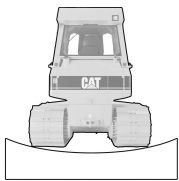

#### Working in a Depression

Causes loads to be carried by the side of components that is on the outside of the machine. This increases wear on the outside wear surface of links, rollers, idler treads, and grouser ends. In extreme cases the outer bushing-sprocket contact surfaces also may experience greater wear.

---

### Application Conditions

---

The word “application” is often misused to describe underfoot condition. It should be thought of as describing what the machine is doing.

#### **Dozing and Push Loading**

Shifts machine weight balance toward the front causing faster wear on front rollers and idlers.

#### **Ripping and Drawbar**

Shifts the weight balance towards the rear of the machine, increasing wear on rear rollers, idlers and sprockets.

#### **Loading (Track-Type Loaders)**

Shifts weight from front to rear of machine as it changes from digging to carrying. The greatest effect is increased wear on front and rear rollers as compared with center rollers.

#### **Excavating with Hydraulic Excavators**

Shifts weight balance from left to right of machine with the possible effect of wearing outer link treads, roller treads and flanges at a greater rate than inner flanges and treads.

## Partially Controllable Variables

---

Some of the variables affecting undercarriage life can only be partially controlled. To some extent they may be influenced by uncontrollable variables but can be partially offset by the operator. These are called operating conditions.

The word “operating” is often misused to describe underfoot or application conditions. It should be thought of as describing what the machine operator is doing.

### Speed

Wear rate is a direct function of speed because wear is a function of distance traveled and not just the time worked.

As speed increases, wear rates increase on all components. Wear rates and impact (structural) effects also increase with speed due to the increased material loads caused by the rate at which the parts contact each other. Link-roller, link-carrier roller, link-idler, and bushing-sprocket wear rates increase as a result of the increased impact between these parts. Shoe and grouser wear rates increase due to the increased impact with the ground. High speed reverse has a particular effect on the bushing-sprocket contact wear rates due to the design of the track. Non-productive speed should be discouraged. Non-productive forward-reverse direction changes should be avoided.

### Turning

Wear rates increase with increased turning. Turning increases interference loads between links and rollers and links and idlers, particularly on rail sides and roller and idler flanges. Turning in reverse can accelerate bushing-sprocket wear as compared to turning in forward. The effects of always turning in one direction can be balanced by changing tracks from one side of the machine to the other half way through their life.

### Slipping Tracks

Wear rates on all components increase when tracks are slipped. Track shoe grousers particularly are affected when tracks are slipped due to the increased sliding between the grouser and the ground. The increased loads that slipping tracks cause is accelerated when the ground is resistive to shear.

### Preferred-Side Dozing or Other Work

Wear rates on the loaded side of a dozer will increase on all components if only one side of the machine is used. Wear rates increase as more power is applied to the loaded side. More slippage and packing will occur on the loaded side; this also increases wear.

Putting more loads and packing onto one side of the machine may result in up to twice the wear rate on that side. This wear rate effect may be balanced by switching all components from one side to the other. This should be done when the link and/or rollers reach half of their potential wear life on the most worn side.



### Components

Each component has individual measurement techniques, wear limits, wear charts, rebuildability criteria, wear patterns and structural problems. The general information for each component is covered in the following section. Specific additions and exceptions are covered in the individual product sections.

### Percent Worn Charts

The percent worn charts section of this handbook translates component measurements into percent worn for Caterpillar parts only.

All percent worn figures shown are percent of time used and not percent of material used. This allows them to be used to directly calculate projected life to the service limit. These charts consider the slower rate of wear when the hardened case is still there and the faster rate of wear that occurs when softer material is exposed.

Charts are provided for high and low impact applications where applicable. Greater and lesser allowable wear charts are also provided for structural integrity for links and bushings on certain machines. Guidance for the selection of high, moderate or low impact and lesser or greater allowable wear charts is provided at the front of each section of wear charts. Measurements corresponding to 100 percent worn (the service limit) are underlined.

In most cases, service limit projections made from less than 30 percent worn cannot be considered accurate. However, such projections can be used to determine call back dates.

Percentages above 100 percent have been provided so projections to 120 percent worn can be calculated. Backward projections to service limit (100 percent) can also be made to determine when the service limit was reached.

A separate discussion under each component sub-section (links, bushings, etc.) describes how the service limit was derived and the risk involved when the component is worn past that point.

---

#### NOTE

*Competitive undercarriage inspection, wear life and maintenance/rebuild projection cannot be determined from information contained in the handbook because of a lack of information about design, expected wear rates and service limits even when some important dimensions are similar.*

---

## Links

---

### Link Rail Wear

---

#### Measurement Technique

Track links may be measured by the depth gauge or by the Ultrasonic Wear Indicator.

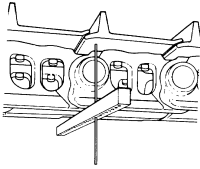

The depth gauge measures link height from the rail surface to the track shoe. The correct location for track link measurement is outside of the links at the end of the track pin. Position the depth gauge as close to the end of the pin as possible, making sure links and shoe surface are clean. Ensure the gauge is flat against the link rails and perpendicular to the shoe surface. Measurement should be made to the closest 0.01 in. or 0.25 mm.

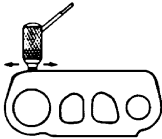

The Ultrasonic Wear Indicator measures the distance from the rail surface to the bushing bore. Place the probe on the link above the centerline of the bushing and slide the probe along the tread surface to get the smallest reading.

#### Wear Limits

Link wear limits are determined by setting the allowable wear equal to some fraction of the clearance between the link and the roller. On some machines this clearance is between the link pin boss and the roller flange. On other machines the clearance is between the bushing and the inner flanges of a double flange roller.

On a 100 percent worn link matched together with a 100 percent worn roller, the roller flanges are in contact with either the link pin bosses or the bushing. As wear proceeds past 100 percent, wear on the link pin boss reduces pin retention, wear on the bushings may cause cracking.

If the link is worn past 100 percent, structural damage may result in the form of cracking, breaking and pin and bushing loosening.

#### Wear Limits — Greater and Lesser

Wear limits for Sealed and Lubricated Track links are determined by remaining crack resistance strength. Two percent worn columns titled “Greater Allowable Wear” and “Lesser Allowable Wear” are provided in link wear charts. At 100 percent worn, the lesser allowable wear column provides more link rail thickness than the greater allowable wear column. Note, for example, in the wear charts under the ultrasonic measurements, the link rail is always thicker, and thus more crack resistant, on the lesser allowable wear column than on the greater allowable wear column.

The selection of optimum allowable wear column will maximize the link life while preventing link cracking. The optimum percent worn column depends on the relative link cracking required in your situation. The amount of required crack resistance depends on several factors including sprocket position (high or low), underfoot conditions, link projected life and application. Refer to the management section in front of each product section for the criteria to use in selecting which allowable wear chart to use.

#### Wear Charts

Wear charts for links have a built in factor allowing for faster wear rate as the hardness of the steel decreases below the hardened case depth. Different wear charts are provided for different links, and for the same link running with different rollers.

## Link Wear Patterns

### Rail (Top) Wear

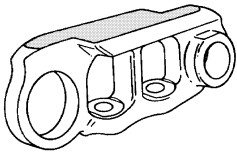

(Normal expected wear position)

**Causes:** Rolling and sliding contact with roller and idler treads.

**Accelerators:** Horsepower, weight, speed, impact, abrasiveness, shoe width, and tight track.

**Remedies:** Eliminate or reduce controllable accelerators listed above.

### Uneven (Scalloping) Wear on Rail Top

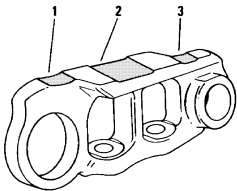

**Causes:** Locations 1 & 3: Faster wear rate due to reduced contact with rollers at narrower link overlap area.

**Causes:** Location 2: Rolling and sliding contact with idler at center of link rail.

**Accelerators:** Same as Rail (Top) Wear above, particularly tight track and machine not balanced.

**Effect:** Machine vibration and wear limit over pin boss reached prematurely.

**Remedies:** Eliminate or reduce controllable accelerators listed above.

### Excessive Pin & Pin Boss Side Wear

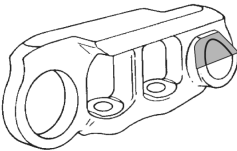

**Causes:** Sliding contact with guiding guards and/or roller guards.

**Accelerators:** Uneven terrain and side-hill operation. Wide shoes, worn track roller flanges, and track roller frame misalignment.

**Remedies:** Eliminate or reduce controllable accelerators.

### Rail Side Wear (inside and/or outside)

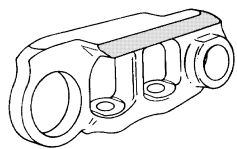

**Causes:** Rolling and sliding contact with roller and idler flanges.

**Accelerators:** Same as "Rail Top Wear" plus uneven terrain, turning, side-hill operation, track roller frame misalignment, and wide shoes.

**Effect:** Reduces rail wear life to service limit.

**Remedies:** Controllable accelerators.

### Rail Inside Wear

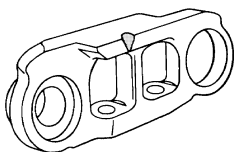

**Causes:** Sprocket tooth interference due to misalignment of track with sprocket, carrier roller and/or idler (see sprocket wear).

**Accelerators:** Side hill or uneven terrain, turning, wide shoes.

**Remedies:** Reduce or eliminate controllable causes and accelerators.

## Links

---

### Link Wear Patterns (Cont'd.)

---

#### Elongation of Counterbore (Sealed Track)

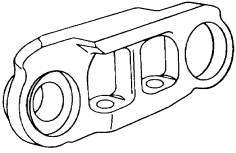

**Causes:** Contact with the bushing end in Sealed Track (see Sealed Track bushing counterbore wear).

**Effect:** Reduces sealability of counterbore even with new seals in Sealed Track.

**Remedies:** Turn pins and bushings in Sealed Track at bushing service limit.

---

#### Depth Wear in Counterbore (Sealed Track)

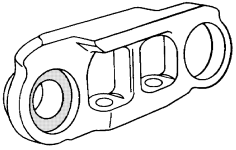

**Causes:** Contact between Sealed Track seals or bushing end with bottom of counterbore (see Sealed Track Bushing End Wear).

**Accelerators:** Abrasiveness, side hill loads, turning, side thrust impact and wide shoes.

**Effect:** Reduces sealability of counterbore even with new seals in Sealed Track.

**Remedies:** Reduce or eliminate controllable accelerators.

---

#### Pin Boss Tip Wear

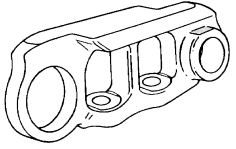

**Causes:** Sliding and rolling contact with track roller flanges (see roller flange wear).

**Accelerators:** Nonuniform wear on track rollers.

**Effect:** Loss of pin retention and reduced ability to turn bushings.

**Remedies:** At mid-life, swap track rollers to balance wear.

---

#### Face Wear (Sealed Track)

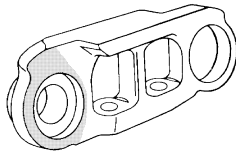

**Causes:** Contact between adjacent link faces following Sealed Track link counterbore depth wear, seal wear and bushing end wear, all which allow end play.

**Accelerators:** Abrasiveness, side hill loads, turning, side thrust impact and wide shoes.

**Remedies:** Reduce or eliminate accelerators.

---

#### Pin Boss End – Guiding Guard Wear

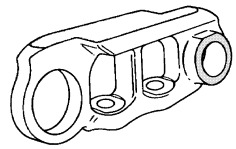

**Causes:** Sliding contact between pin boss ends and guiding guards or roller guards.

**Accelerators:** Side hill or uneven terrain, turning, wide shoes.

**Effect:** Loss of pin retention and reduced ability to turn bushings.

**Remedies:** Reduce or eliminate controllable accelerators.

---

---

**Link Structural Problems**

---

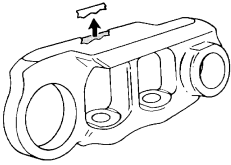
**Rail Spalling**

**Causes:** Repeated high impact contact with roller treads and / or flanges.

**Accelerators:** Impact, machine speed, horsepower, weight, wide shoes , and tight track.

**Effect:** May reduce wear life if over 30 percent of rail surface is affected; otherwise only a cosmetic effect.

**Remedies:** Reduce or eliminate controllable accelerators, particularly wide shoes that leverage loads on uneven terrain.

---

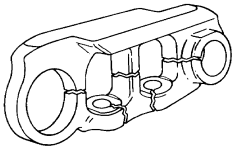
**Link Cracking**

**Causes:** Repeated twisting of link.

**Accelerators:** Same as "Rail Spalling" plus rail material worn away. The biggest accelerator is wide shoes.

**Effect:** Short link assembly life and track separation.

**Remedies:** Reduce or eliminate controllable accelerators particularly wide shoes and tight track.

---

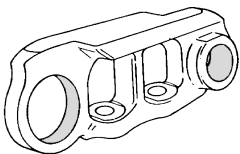
**Pin & Bushing Bore Enlargement**

**Causes:** Bore material broached out during bushing turn; material stretched during movement of flexing pins and bushings.

**Accelerators:** Same as "Rail Spalling" plus material worn off of pin bosses. The biggest accelerator is wide shoes.

**Remedies:** (1) Improve track press alignment and tooling to prevent broaching during bushing turn.

(2) Reduce or eliminate controllable accelerators especially wide shoes and tight track.

---

## Links

---

---

### Split Master Link

---



Five Tooth Master Link



Single Tooth Master Link  
D10/D11

Measuring and interpreting master link rail and other wear patterns is the same for the split master link as for regular link.

**Split master link structural problems are usually related to improper assembly and bolt tightening. Split master links are even more susceptible to detrimental effects of wide shoes.**

## Assembling and Tightening Procedure

See the following Undercarriage Reconditioning Bulletins for detailed Installation and Removal instructions for Master Links:

REHS2220 – Installation and Removal of SystemOne Clamp Masters

SEBF8620 – Reusability Guidelines for Single Tooth Master Links

SEBF8621 – Shop Disassembly and Assembly of Single Tooth Master Links

SEBF8622 – Field Removal and Installation of Single Tooth Master Links

The importance of proper assembly sequence and torquing cannot be overstressed. Follow these steps for both new and used split master links.

To ensure proper master link life and bolted joint integrity, the specified torque plus turn procedure must be properly followed. Note that Five Tooth and Single Tooth torque turn angle values are different as the bolts have different threads.

1. Before installing the track, the point of connection for the master link must be clean and not have damage. Remove all paint from points of connection.
2. Apply anti-seize compound to bolt threads, body, washer face, and bolt contact areas on the shoe during assembly.
3. Put master links together and check alignment of holes for master bolts. Install one master bolt in each link. Bolts must turn easily in the threads when turned by hand.
4. Remove the bolts. Install the master track shoe and all four master bolts. Turn the master bolts by hand.
5. Tighten the master bolts to initial torque, plus turn. The actual Torque specifications can be found in the Management section of each machine type.

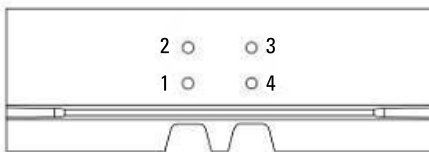

Torque sequence for open window clamp master

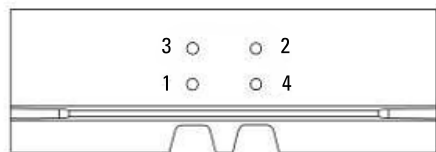

Torque sequence for standard track and center strut clamp master

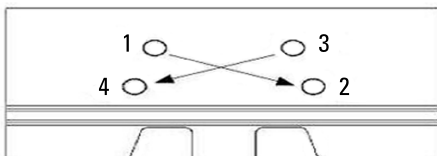

Torque sequence for single tooth master

## Former Link Service Limits

These former links do not appear on wear chart pages. But, by using this procedure and chart you can calculate the percent worn measurement.

$$\begin{array}{l} \text{STEP 1} \\ \text{New Link Height} - \text{Worn Link Height} = \text{Amount Worn} \end{array} \qquad \begin{array}{l} \text{STEP 2} \\ \text{Amount Worn} \\ \text{Allowable Wear X 100} = \text{Percent Worn} \end{array}$$

Model	Track Pitch	Link Part Number	New Link Height	Allowable Wear	Service	
D2	6.12 in (155.4 mm)	5B-3129 & 30	3.00 in (76.2 mm)	.25 in. (6.4 mm)	2.75 in (69.9 mm)	
D3	6.125 in. (155.3 mm)	6S-3143 & 44	3.18 in (81 mm)	.26 in (7 mm)	2.92 in (74 mm)	
D4	6.75 in. (171.5 mm)	5K-9423 & 24	3.66 in (93.0 mm)	.25 in (6.4 mm)	3.41 in (86.6 mm)	
	6.75 in (171.5 mm)	5K-9457 & 58	3.66 in (93.0 mm)	.25 in. (6.4 mm)	3.41 in (86.6 mm)	
	6.75 in. (171.5 mm)	4K-6647 & 48	3.66 in (93.0 mm)	.25 in (6.4 mm)	3.41 in (86.6 mm)	
	6.75 in (171.5 mm)	4K-7039 & 40	3.66 in (93.0 mm)	.25 in (6.4 mm)	3.41 in. (86.6 mm)	
	6.75 in. (171.5 mm)	6B-4645 & 46	3.53 in. (87.7 mm)	.25 in (6.4 mm)	3.28 in. (83.3 mm)	
D5	6.91 in (175.5 mm)	5S-683 & 84	4.06 in (103.1 mm)	.37 in. (9.4 mm)	3.69 in (93.7 mm)	
D6	8.00 in (203.2 mm)	9M-5627 & 28	4.50 in (114.3 mm)	.30 in (7.6 mm)	4.20 in (106.7 mm)	
	6.75 in (171.5 mm)	2S-5959 & 60	4.00 in (101.5 mm)	.34 in (8.6 mm)	3.66 in (93.0 mm)	
	6.75 in (171.5 mm)	7M-8863 & 64	3.91 in (99.3 mm)	30 in. (7.6 mm)	3.61 in (91.7 mm)	
D7	8.50 in (215.9 mm)	2S-1749 & 50	4.75 in (120.7)	.35 in (8.9 mm)	4.40 in (111.8 mm)	
	8.50 in. (215.9 mm)	1M-9001 & 02	4.75 in (120.7 mm)	.35 in (8.9 mm)	4.40 in (111.8 mm)	
	8.00 in (203.2 mm)	1S-6433 & 34	4.63 in (117.6 mm)	.38 in (9.7 mm)	4.25 in (108.0 mm)	
	8.00 in. (203.2 mm)	7M-8085 & 86	4.50 in (114.3 mm)	.38 in. (9.7 mm)	.38 in (9.7 mm)	
	8.00 in. (203.2 mm)	1S-1863 & 64 1S-6433 & 34	4.62 in (117.5 mm)	.38 in (9.7 mm)	4.24 in (107.5 mm)	
	8.00 in. (203.2 mm)	7M-6763 & 64	4.50 in. (114.3 mm)	.38 (9.7 mm)	4.12 in (104.6 mm)	
	8.00 in. (203.2 mm)	2M-7265 & 66	4.50 in. (114.3 mm)	.38 in (9.7 mm)	4.12 in (104.6 mm)	
	D8	9.00 in (288.6 mm)	1S-4033 & 34	5.25 in (133.3 mm)	.42 in (10.7 mm)	4.83 in (122.7 mm)
		9.00 in (288.6 mm)	2M-8813 & 14	5.12 in (130.0 mm)	.38 in. (9.7 mm)	4.74 in (120.7 mm)
9.00 in (288.6 mm)		2M-8813 & 14	5.12 in (130.0 mm)	.37 in (9.7 mm)	4.75 in (116.6 mm)	
9.00 in. (288.6 mm)		9M-3843 & 44	5.12 in (130.0 mm)	.37 in (9.7 mm)	4.75 IN (120.7 mm)	
8.00 in (203.2 mm)		1S-8839 & 40	4.97 in (126.2 mm)	.38 in (9.7 mm)	4.59 in (116.6 mm)	
8.00 in. (203.2 mm)		7H-3799 & 800	4.88 in (124.0)	.33 in (8.4 mm)	4.55 in (115.6 mm)	
D9	10.25 in. (260.4 mm)	9S-1927 & 28	6.12 in (155.5 mm)	.50 in (13.0 mm)	5.62 in (142.5 mm)	
	10.25 in (260.4 mm)	7S-3925 & 26	5.68 in (144.5 mm)	.38 in (10.0 mm)	5.30 in. (134.5 mm)	
	10.25 in. (260.4 mm)	1S-6323 & 24	5.68 in (144.5 mm)	.38 in (10.0 mm)	5.30 in (134.5 mm)	
	10.25 (260.4 mm)	8M-6901 & 02	5.56 in. (141.2 mm)	.37 in. (9.4 mm)	5.19 in (131.8 mm)	
	10.25 (260.4 mm)	2M-5649 & 50	5.56 in (141.2 mm)	.37 in (9.4 mm)	5.19 (131.8 mm)	
	9.00 in. (228.6 mm)	2M-1623 & 24	5.25 in. (133.4 mm)	.35 in (8.9 mm)	4.90 in. (124.5 mm)	
	9.00 in. (228.6 mm)	2F-5879 & 80	5.000 in. (127.0 mm)	.38 in (9.7 mm)	4.62 in. (117.3 mm)	



## Sealed & Lubricated Track Bushing Wear

### Measurement Technique

The track bushing is the most important component in the undercarriage to measure and interpret accurately.

To do this, three measurement methods are available.

You should refer to individual model family sections for specific recommendation on which method to use because the third tool described here, the depth gauge, records vertical position wear only.

### 1. Ultrasonic Wear Indicator Method

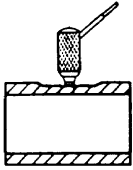

This method is the most accurate because it directly measures the most critical dimension, bushing wall thickness. It also can be used to accurately measure bushings after a bushing turn.

Measure the bushing wall thickness by slowly sliding the probe around the reverse, vertical, and forward drive sides. Use the smallest dimension to determine percent worn.

### 2. Caliper Method

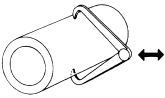

This method measures the bushing diameter. With careful cleaning and proper technique it can be accurate, but is susceptible to error if not properly measured. The most common errors using the caliper method are:

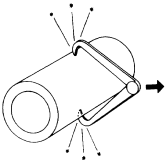

(A) Calipers Squeezed Too Tight — Calipers that are over-tightened can be spread like a spring, providing a measurement that is too small.

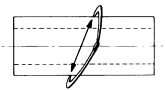

(B) Calipers at Wrong Angle to Bushing Axis — Calipers that are set at an angle to the bushing will give an oversize measurement.

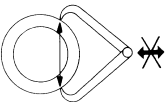

(C) Calipers Not Slid Back and Forth Across Position to be Measured — Calipers that are not passed back and forth over the diameter of the bushing position being measured will give an undersize reading.

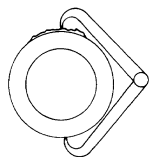

(D) Bushing not Cleaned Well Before Measurement — If the bushing surface is not clean the measurement taken will be oversized.

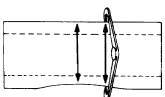

(E) Calipers Not Placed at Most Worn Portion of Bushing — If the caliper is located inboard or outboard of the minimum diameter along its length the measurement will be undersized.

# Sealed & Lubricated Track Pins & Bushings

## Sealed & Lubricated Track Bushing Wear (Cont'd.)

### PRACTICE!

The best way to practice measuring bushing wear is with bushings removed from the track. You should be able to repeat the measurements made by yourself and others with an accuracy of  $\pm 0.01$  in. ( $\pm 0.25$  mm).

### 3. Depth Gauge Method

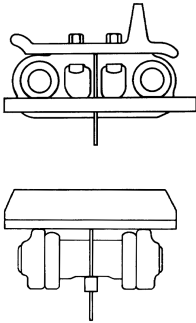

The method for measuring the vertical position of bushings uses the same depth gauge used for links. This method is more free of the measurement technique errors encountered with the caliper, but may be subject to slight track link dimensional differences and track shoe bending. It is also subject to the same technique errors as link height measurements. These include: (a) parts not cleaned, (b) depth gauge base not positioned correctly with respect to bushing length and (c) depth gauge probe not forming a perpendicular or  $90^\circ$  angle with the shoe.

#### Disadvantages of the depth gauge method

(A) Cannot determine reverse or forward drive side wear, which is critical in most applications.

#### Advantages of the Depth Gauge Method

(A) Backside of bushing can be measured after bushing turn (the importance of this will be explained in the next discussion).

## Sealed and Lubricated Track Bushing Wear

### Measurement Positions

Refer to individual product sections for specific guidelines.

### Wear Limits — Greater and Lesser

Wear limits for Sealed and Lubricated Track bushings are determined by remaining crack resistance strength. Two percent worn columns titled “Greater Allowable Wear” and “Lesser Allowable Wear” are provided in bushing wear charts. At 100 percent worn, the lesser allowable wear column provides more bushing wall thickness than the greater allowable wear column. Note, for example, in the wear charts under the ultrasonic measurements, the bushing wall is always thicker, and thus more crack resistant, on the lesser allowable wear column than on the greater allowable wear column.

The selection of the optimum allowable wear column will maximize the bushing life while preventing bushing cracking. The optimum percent worn column depends on the relative bushing crack resistance required in your situation. The amount of required crack resistance depends on several factors including sprocket position (high or low) underfoot conditions, bushing projected life and application. Refer to the management section in front of each product section for the criteria to use in selecting which allowable wear chart to use.

### Wear Charts

The bushing wear rate after the hardened case has been completely worn through is approximately 2 times the rate expected in the hardened case depth. As with most other components, projections made to the service points based on less than 30 percent worn will not be accurate.

### Sealed & Lubricated Track Bushing Wear (Cont'd.)

---

#### **Sealed and Lubricated Track vs. Sealed Track**

The expected life of the Sealed and Lubricated Track bushings is approximately 50 percent more than the Sealed Track bushings.

This increase depends on the following:

1. The amount of internal wear that contributed to the external wear on the Sealed Track bushing.
2. Properly adjusted track.
3. Absence of severe packing.
4. Similar working conditions.

#### **Sealed and Lubricated Track Bushing Turnability**

The Sealed and Lubricated Track bushing should be turned based on the guidelines in following sections entirely devoted to specific model families.

The bushing may be expected to provide life after turn wear equal to or exceeding the wear life of the first or front side prior to the turn.

Sealed and Lubricated Track bushings may be successfully turned dry, (with or without internal wear at turn time) as long as there are no cracks through the bushing wall and internal wear does not exceed Sealed Track service limits.

**Life after dry turn cannot be expressed as a percent of wet life before turn. It will most closely approximate life after turn of Sealed Track.**

# Sealed & Lubricated Track Pins & Bushings

---

## How to Interpret Sealed & Lubricated Track Bushing Wear Patterns

---

These patterns are found on wet joints. For dimensions on wear patterns of dry joints see Sealed Track bushings.

---

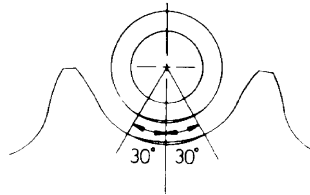

**Vertical Position** ( $0^\circ$  to  $30^\circ$  from vertical is normal expected wear pattern on low sprocket machines).

**Causes:** Sliding contact with root of sprocket tooth during forward to reverse direction changes and due to pitch mismatch from minor packing and advanced sprocket wear.

**Accelerators:** Horsepower, weight, speed, impact, abrasiveness, tight track, packing, and wide shoes.

**Effect:** Cracking will occur when 100% wear is exceeded using the lesser allowable wear column.

**Remedies:** Eliminate or reduce controllable accelerators.

---

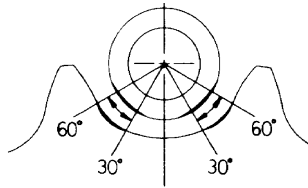

**Reverse Drive Side** ( $30^\circ$  to  $60^\circ$  from vertical is the normal wear pattern on elevated sprocket machines)

**Causes:** Sliding contact with the sprocket.

**Accelerators:** Excessive reverse operation, tight track, packing and reverse operation up-hill.

**Effect:** Short wear life of bushings.

**Remedies:** Eliminate tight track and minimize reverse operation.

**Forward Drive Side** ( $30^\circ$  to  $60^\circ$  from vertical)

**Causes:** Contact with the sprocket under load.

**Accelerators:** Packing and worn bushings & sprockets.

---

## How to Interpret Sealed & Lubricated Track Bushing Wear Patterns (Cont'd.)

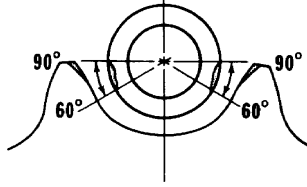

### Reverse and/or Forward Drive Side Pocket Wear (60° to 90° from vertical)

**Causes:** (1) Sliding contact with the sprocket due to: (1) Severe packing. (2) On low sprocket machines track is too loose, causing “back jamming” at the bottom of the sprocket in reverse operation.

**Accelerators:** Packing, uphill reverse loading of machine with loose track.

**Effect:** (1) Short wear life of bushings. (2) Track may jump over sprocket teeth if sprocket tooth tip height is worn excessively.

**Remedies:** Eliminate or reduce controllable accelerators.

### Off Center Wear

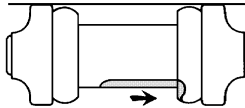

**Causes:** Misalignment of track and sprocket.

**Accelerators:** (1) Alignment problems with track roller frame, track roller, carrier roller and/or sprocket. (2) Worn rear guiding and/or final drive guiding guards. (3) Side-hill operation.

**Effect:** Should not increase wear rate of bushing to wear limits.

**Remedies:** (1) Correct alignment. (2) Replace guiding and/or final drive guiding guards.

### Roller Flange Wear

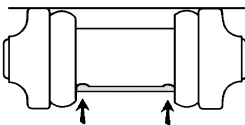

**Causes:** Track Rollers inner flanges and/or carrier roller flanges contacting bushing due to one or more of (a) links (b) carrier rollers or (c) track rollers being well past 100 percent worn.

**Effect:** Causes bushing to be prematurely fail.

**Remedies:** Replace carrier rollers or track rollers.

# Sealed & Lubricated Track Pins & Bushings

---

## Sealed and Lubricated Track Bushings Structural Problems

---

### Bushing Cracks (Through the wall)

---

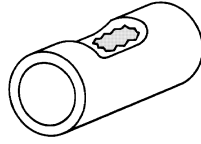

**Causes:** Exceeding 100% wear.

**Accelerators:** Wide shoes, high loads.

**Effect:** (1) Loss of lubricant and resulting internal wear. (2) Bushing is not reusable.

**Remedies:** Re-evaluate decision to run past wear limit.

---

### Bushing (and/or Pin) Loose in Link

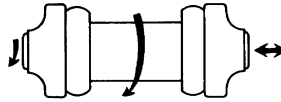

**Causes:** Bore material broached out during bushing turn; material stretched during movement of flexing pins and bushings.

**Accelerators:** (1) Severe repeated impact loads (biggest accelerator is wide shoes). (2) Improper track press alignment or damaged track press tooling.

**Effect:** (1) Loss of press-fit into link bores. (2) Loss of lubricant. (3) Pin, Bushing and Links not reusable.

**Remedies:** (1) Reduce or eliminate controllable variables which accelerate impact. (2) Control track press alignment capability and use acceptable tooling.

---

### Dry Sealed and Lubricated Track Joints

---

Premature dry joints in Caterpillar Sealed and Lubricated Track maybe detected by any of the following methods:

1. Identifying warm joints using an infrared temperature gun or hand feeling the pin ends after the machine has been operating.
2. Measuring or seeing pitch extended (internal wear) over single sections of track.
3. Finding bushings significantly more worn than others in the same track.

Refer to the individual product sections for the single joint wear limits.

---

### Wear and Structural Problems on Sealed and Lubricated Track Pins

---

Once dry, the wear pattern and rate on Sealed and Lubricated Track pins and bushings should be approximately equal to the wear on Sealed Track. For a discussion of those wear patterns, see the section entitled "SEALED TRACK PINS & BUSHINGS."

There are four types of Sealed and Lubricated Track pin wear/structural problems.

#### Pin Galling

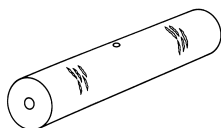

**Causes:** Metal-to-metal contact (without lubrication) between the pin and bushing.

**Accelerators:** Impact underfoot conditions, tight track , severe packing, wide shoes and lack of lubrication.

**Effect:** Score marks on pin surface. Pin may be reusable at bushing turn time. This is only a cosmetic problem and does not result in track pitch extension like internal wear.

**Remedies:** Eliminate or reduce accelerators (especially tight track and wide shoes).

---

# Sealed & Lubricated Track Pins & Bushings

---

## Wear and Structural Problems on Sealed and Lubricated Track Pins (Cont'd.)

---

### Pin Spalling

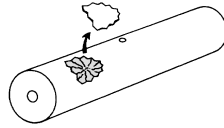

**Causes:** Flexing pin causes cracks to begin in the oil reservoir hole and spread out to the surface at a slow fatigue rate.

**Accelerators:** Same as "Pin Galling."

**Effect:** Chip or flake of material may become loose from pin surface. Pin should not be reused at bushing turn time.

**Remedies:** Eliminate or reduce accelerators (especially tight track and wide shoes).

---

### Pin Breakage

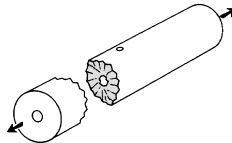

**Causes:** Crack starts on outer surface and spreads through entire pin at a fast rate. This is not nearly as common as with Sealed Track Pins.

**Accelerators:** High impact underfoot conditions, tight track, severe packing, wide shoes.

**Effect:** Track separation with little or no warning.

**Remedies:** Eliminate or reduce controllable accelerators, particularly wide shoes and entry of non-extrudable packing materials (rocks, etc.) into the sprocket bushing contact area.

---

### Pin End Wear

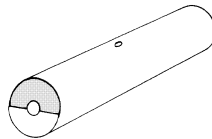

**Causes:** Sliding contact with track guiding guards, track roller guards and/or rocks.

**Accelerators:** Uneven terrain, side-hill operation, wide shoes, and misalignment.

**Effect:** Turning pins & bushings may be more expensive.

**Remedies:** Eliminate or reduce controllable accelerators.

---



### Sealed Track Bushing Wear

---

In early hours, the wear patterns on Sealed Track bushings should be very similar to those shown for Sealed and Lubricated Track. However, as internal wear takes place, the external wear pattern will change positions and accelerate, thus reducing bushing life due to greater interference loads and sliding motion against the sprocket.

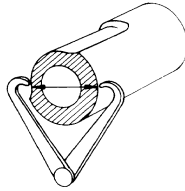

#### Measurement Technique

The Ultrasonic Wear Indicator or small caliper must be used to measure wear at the vertical, forward and reverse drive locations to identify the minimum wall thickness. This is because the Sealed Track bushings must have sufficient strength to resist cracking after the turn.

For a discussion on errors that can be made using the caliper to measure bushings, see the section entitled "Sealed and Lubricated Track Bushing Wear Measurement Technique — Caliper Method."

#### Wear Limits

As mentioned above, wear limits for Sealed Track bushings are determined on the basis of remaining strength before and after the turn. The allowable wear for Sealed Track external bushings is considerably less than for the Sealed and Lubricated Track bushings. The lesser allowable wear to the service point is 0.12 in. (3.1 mm). The greater allowable wear to the service point is 0.19 in. (4.8 mm). Wear limits should always be chosen on the basis of degree of expected impact, not on the basis of abrasiveness or desired life.

Wear charts for Sealed Track bushings have the built-in effect of (a) approximately twice as fast expected wear rate after the bushing case depth is worn through and (b) a faster yet expected wear rate (approximately three times) after a significant amount of internal wear would have further accelerated wear due to greater interference loads and relative motion between the bushing and the sprocket.

---

### How to Interpret Wear on Sealed Track Bushings

---

Since the successful turnability and total life of Sealed Track pins and bushings is a function of both internal and external wear, interpretation of external bushing wear alone will not accurately determine if and when to turn. However, the type and degree of external bushing wear is a good indicator of abnormal problems. Knowledge of these patterns and the causes of each will be useful.

# Sealed Track Pin & Bushings

---

## External Wear

---

The early hour wear patterns for Sealed Track bushings are similar to those for Sealed and Lubricated Track due to little or no internal wear. Shown here are typical wear patterns for late hour normal conditions where internal wear has begun to have a measurable pitch extension effect on the external pattern.

---

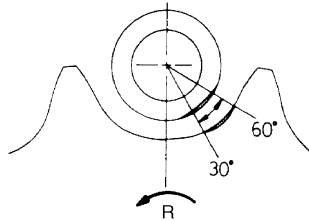

**Reverse Drive Side Wear is Critical** (30° to 60° from vertical)

**Causes:** Rotation and sliding contact with the sprocket.

**Accelerators:** Excessive reverse operation, tight track, speed and abrasiveness.

**Remedies:** Reduce or eliminate controllable accelerators.

---

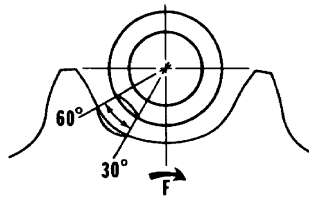

**Forward Drive Side Wear is Critical** (30° to 60° from vertical)

**Causes:** Rotation and sliding contact with the sprocket.

**Accelerators:** Same as Reverse Drive Side described above plus uneven terrain and worn rear rollers.

**Remedies:** Eliminate or reduce controllable accelerators such as tight track and worn rear rollers.

---

## Off-Center Wear Pattern and Roller Flange Wear Pattern

See "How to Interpret Sealed and Lubricated Track Bushing Wear Patterns."

---

## Other Wear Patterns — Disassembled Track

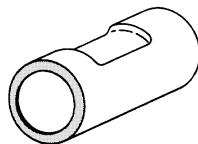

### Bushing End Wear

**Causes:** Contact between seal or abrasive and link counterbore.

**Accelerators:** Abrasiveness, side hill loads, turning, side thrust impact and wide shoes.

**Effects:** Reduces sealability of joint at turn time. Reduces internal wear life after turn.

**Remedies:** Keep guiding components in good condition.

### External Wear (Cont'd.)

---

---

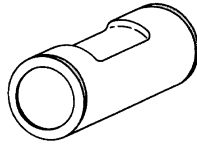

#### **Bushing — Link Counterbore Wear**

**Causes:** Rotational sliding contact with link counterbore due to track pitch extension from internal wear.

**Accelerators:** Abrasiveness, side hill loads, turning, side thrust impact and wide shoes.

**Effects:** Reduces sealability of joint. Reduces internal wear life after turn.

---

### Structural Problems on Sealed Track Bushings

---

The limitation of a Sealed Track joint is usually due to structural failure in the bushing caused by cracking or loosening after exceeding 100% worn internally or externally.

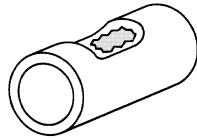

#### **Bushing Breaks Through the Entire Wall**

**Causes:** Exceeding internal and/or external wear limit (100% worn).

**Accelerators:** Loads between sprocket and bushing caused by weight, speed, impact, wide shoes, worn rear rollers and tight track.

**Effects:** Bushing not reusable during turn. Unscheduled down time.

**Remedies:** Eliminate or reduce controllable accelerators.

---

#### **Bushing Loose in Links**

See "Sealed and Lubricated Track Bushing Structural Problems."

---

## Sealed Track Pin & Bushings

---

---

### Sealed Track Pitch Internal Wear

---

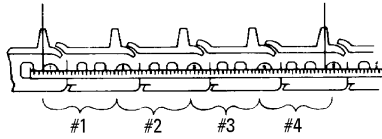

#### Measurement Technique

Sealed Track internal wear is measured by determining the pitch extended length over four adjacent sections with a tape measure calibrated in 0.02 in. (0.5 mm) increments.

Except on 5230, measure only 3 adjacent sections.

The track and tape must be stretched tight and straight to obtain an accurate measurement. The reading should be made from one side of a pin to the same side of the fourth pin away (to include 4 track sections).

The hook on the 0 in. (0 mm) end of the tape should not be used (see diagram above). This measurement should be taken at least 3 sections away from one-piece type master link joints and should be repeated at least twice over different sections of the track on both sides of the machine. This measurement can be used directly to find percent worn in the charts.

#### Wear Limit and Percent Worn Chart

The wear limits and wear charts for internal wear include only the 0.12 in. (3.1 mm) per joint lesser allowable wear.

---

## Wear and Structural Problems on Sealed or Dry Track Pins

---

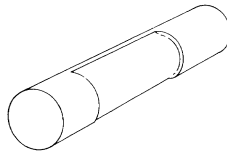

#### Internal Wear (Pin O.D. Wear and Bushing I.D. Wear)

**Causes:** Rotational contact with abrasive and/or bushing.

**Accelerators:** Tight track, wide shoes, worn rear rollers, high speed, abrasiveness, loss of sealing, impact, and packing.

**Effect:** Track pitch increase with resulting mismatch (see sprocket wear patterns).

**Remedies:** Eliminate or reduce controllable accelerators, turn Sealed Track pins and bushings at service limit. Use Sealed and Lubricated Track.

---

### Wear and Structural Problems on Sealed or Dry Track Pins (Cont'd.)

---

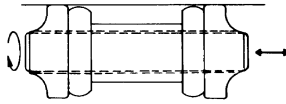

#### Pin Loosening

**Causes:** Loss of press fit retention in link pin bore.

**Accelerators:** (1) Severe repeated impact yields or cracks link bore. (2) Uneven terrain and too-wide shoes increase flexing of pin in bores. (3) Link bore broached by improper track press alignment at reassembly time. (4) Loose track shoes.

**Effect:** Loss of pin and separation of track; loss of parts reusability and rebuildability.

**Remedies:** (1) Eliminate or reduce controllable variables which increase impact loads and flexing of joint such as too-wide shoes. (2) Control track press alignment capability and re-chamfer worn pin ends to reduce bore broaching.

Also reference "Wear and Structural Problems on Sealed and Lubricated Track Pins."

---

### Sealed Track Pins & Bushing Turn and Replacement Guidelines

---

The following guidelines should be used in determining if and when Sealed Track pins and bushings should be turned and/or replaced. The general guidelines discussed in the section entitled "Track Management" should be understood and practiced before applying these specifics.

1. If a pin and bushing turn is required, it should be done on or before either the internal wear or external bushing service points (100 percent worn) are reached.
2. If a pin and bushing replacement is required following the turn of a previous set of pins and bushings, it should be done on or before either the internal wear exceeds the service point (100 percent worn) or the external bushing surface is run to destruction (120 percent worn).
3. When in doubt, turn early for best after turn or replacement wear and structural life performance.

---

### Grease Lubricated Track Pins & Bushings

---

Excavators are equipped from the factory with Grease Lubricated Track (GLT). These Tracks are similar to Sealed Track, with the added benefit of joint (pin & bushing) lubrication with grease and track seals. Unlike Sealed and Lubricated Track, the GLT will not provide lubrication for the life of the track.

For as long as the GLT track joint retains the grease, there will be no internal wear of the bushing and pin. Once the grease lubrication is depleted, internal wear will begin in the same manner as Sealed Track. The length of time that the joints remain lubricated will vary with the excavator model, but generally the lubricated life will range from 1200 to 2500 hours.

#### Measurement Technique

All measurements for GLT follow the same procedures as described previously for Sealed Track. In many cases external bushing wear will be the limiting wear factor compared to internal bushing wear for Sealed Track.

## Shoes

---

### Grouser Wear

---

#### Measurement Technique

Grouser wear is the only measurable wear position on the shoe for which limits and percent worn charts are provided. Plate thickness can be measured and compared with new dimension to determine wear. Track shoes may be measured with the Ultrasonic Wear Indicator or the depth gauge.

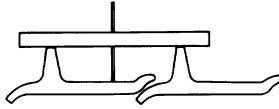

The Ultrasonic Wear Indicator measures the distance from the tip of the grouser to the bottom of the plate. This measurement should be taken 1/3 of the way in from the outer edge of the shoe and the probe can be placed either on the top or bottom. On double grouser and triple grouser shoes, do not measure the rear grouser bar due to interference with the shoe trailing edge. On regrousered shoes, if the weld does not completely penetrate, the instrument may read only the thickness of the grouser bar. In this case, a depth gauge will be required to determine percent worn.

Grouser height wear is measured with the depth gauge, setting the base across two adjacent grousers and measuring down to the plate. The position of the depth gauge should be 1/3 of the way in from the outer edge of the shoe. When measuring single grousers, two shoes must be spanned and the track should be straight between these two sections. Measurements should be made to the closest 0.02 in. or 0.5 mm.



#### Wear Limits

Wear limits for all shoes are based on three criteria, in the following order:

1. Remaining beam or bending resistance strength width shoe.
2. Remaining grouser base available for regrousering purposes.
3. Remaining traction-penetration ability of the shoe to prevent production losses.

The service point is represented by 100 percent worn.

#### Wear Charts

Shoe percent worn rates reflect an approximate uniform rate of wear to the service and destruction limits. Only a minor allowance has been built into the charts for faster rate of wear after the grouser case depth is worn away, since the rate does not change appreciably.

---

### Track Shoe Cause and Effect Performance

---

Shoe wear and structural life is more affected by underfoot conditions and application than any other component in the undercarriage system. However, proper selection of shoe type and width has a substantial impact on the performance of other undercarriage components.

## How to Interpret Shoe Wear Patterns

### Grouser Wear

**Causes:** Sliding contact with underfoot material.

**Accelerators:** Weight, speed, impact, abrasiveness, and operating practices that cause non-productive slippage, turning or sliding.

**Effects:** Loss of traction, bending strength and regrouserability.

**Remedies:** (1) Reduce or eliminate controllable accelerators. (2) Use extreme service or super extreme service shoes if moderate service shoe life is too short to match link or bushing life.

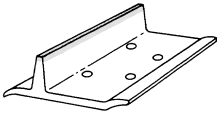

### Plate Wear and Leading/Trailing Edge Wear

**Causes:** Same as grouser wear.

**Accelerators:** Same as "Grouser Wear."

**Effects:** Worn leading and trailing edges allow debris to enter the undercarriage system, reducing wear life of all other components (especially bushings, links and rollers). Plate wear causes loss of bending or beam strength and may prevent successful regrousering.

**Remedies:** Reduce or eliminate controllable accelerators.

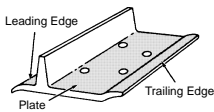

### Grouser Corner Wear

**Causes:** Same as "Grouser Wear."

**Accelerators:** Same as "Grouser Wear" except terrain is probably rougher. Wide shoes in high impact condition on rough terrain will accelerate this effect particularly where much turning is evident.

**Effects:** Reduces effective shoe wear life and regrouserability.

**Remedies:** Reduce or eliminate controllable accelerators and use the narrowest shoe that will give adequate flotation.

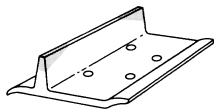

## Shoe Structural Problems

### Shoe Bending, Cracking and Breaking

**Causes:** Bending load on shoe exceeds shoe beam strength due to loss of grouser and plate wear material and/or shoe too wide for underfoot conditions.

**Accelerators:** Same as "Shoe Grouser Wear," particularly shoe width.

**Effect:** Loss of unused shoe wear life. Loss of regrouserability.

**Remedies:** Use heavier extreme service or super extreme service shoes and/or narrower shoes.

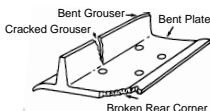

# Shoes

## Shoe Structural Problems (Cont'd.)

### Bolt Hole Wallowing Out (With loose hardware)

**Causes:** Loss of clamping between shoe and link or loose bolts.

**Accelerators:** (1) Same as "Shoe Bending Cracking and Breaking" particularly wide shoes, plus having too much turning resistance resulting from high grouser. (2) Incorrectly tightened hardware.

**Effects:** Loss of unused shoe wear life; loss of shoe regrouserability; damage to link bolt holes and resulting loss of wear life.

**Remedies** (1) Use narrowest shoe that will give adequate flotation. Clip ends of grouser to reduce turning resistance of wide shoes. (2) Use multi-grouser shoes to reduce turning resistance. (3) Use extreme service shoe if single grouser shoe is bent.

Tighten (and retighten) hardware if necessary according to proper torque procedure and specifications.

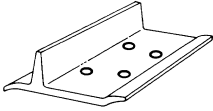

## Proper Shoe Selection

Shoe selection should be based on the underfoot conditions, machine application and undercarriage wear life. The best general rule is to choose the narrowest shoe that provides adequate flotation.

Some choices require compromise. Make the user aware of the advantages (productivity) and disadvantages (reduced undercarriage component life). A good example is very wide shoes that can vastly increase productivity by working in places no other machine could, but with an expected undercarriage wear and structural life of as little as 1/10 of the same sized machine working on firm soil with standard width shoes. Use the following chart to weigh the factors.

### Proper Shoe Selection Chart

These As these increase . . .	Machine Productivity Factors				Undercarriage System Wear & Structural Life Factors		
	Flotation	Penetration Traction	Maneuver- ability	Versatility	Shoe W.L.	Shoe S.L.	Other Undercarriage Component W.L. & S.L.
Shoe Width (grouser & plate)	↑	⇒	↓	↑	⇒	↓	↓
Shoe Section Thickness	⇒		⇒	⇒	↑	↑	
Number of Grousers	⇒	↓	↑		↓	↑	
Height of Grousers	⇒	↑	↓	⇒	↑	↑	

W.L. = Wear Life      S.L. = Structural Life

How to use this chart:

1. First identify the machine productivity factors that are most important to the user.
2. Note the other productivity effects of the shoe that were identified.
3. Look straight across to find what wear and structural life effects may be expected.



---

## Modify Shoes for Special Conditions

---

Caterpillar offers a wide range of shoe types and sizes to meet most needs, however, dealers or users may wish to modify them to balance machine productivity and undercarriage life. Following is a brief description of some modifications.

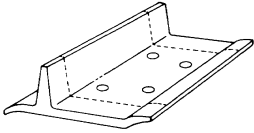

### Shortening or Offsetting

Shoes may be cut off at one or both ends to reduce width on inner and/or outer sides as required.

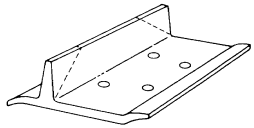

### Extreme Clipping

Shoes may have the grouser corners cut off to reduce turning resistance and bending force without loss of flotation and with little loss of overall wear life.

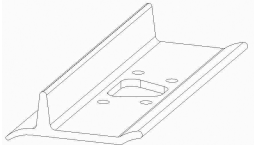

### Center Holes

Shoes may have a hole cut between the bolts to provide a place to relieve extrudable type packing material. (See discussion on Extrudable and Non-extrudable Material under “Soil and Underfoot Conditions – Packing”). Should not be done in rocky conditions due to possible entry of rocks into track system.

---

## Correctly Fasten Shoes

---

The principle controllable cause of shoe loosening is inadequately tightened shoe hardware. Refer to the special assembling and torquing procedure for master shoes [on, page 29](#). Use the following procedure to tighten and re-tighten regular track bolts. When experience dictates, track hardware should be re-tightened after 50-100 hours of operation.

1. Remove all rust and paint from mating surfaces of links and shoes.
2. Lubricate the bolt threads and bolt washer faces.
3. Tighten the bolts to the specified torque.
4. Give each bolt an additional 1/3 turn.

Initial torque draws the parts together tightly. An additional 1/3 turn gives the bolt proper stretch for good retention. Stretching stresses the bolt until some permanent deformation occurs in the bolt. The deformation insures that the bolt’s maximum clamping force is used.

---

### NOTE

See Individual Model Family Sections for Shoe Bolt Torque Specifications.

---

## Self-Locking Track Nuts

---

Self-Locking Track Nuts are installed with the rounded corners against the link and the chamfered edges away from the link.

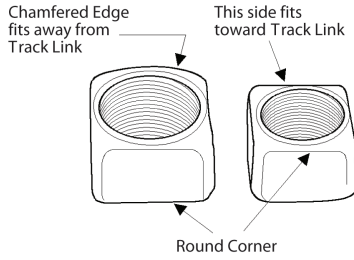

## Idler Wear – Conventional Idlers

### Measurement Technique

Tread and center flange wear are the measurable wear positions on idlers.

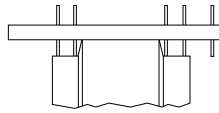

Tread wear is determined by measuring with the depth gauge from the idler center flange to the tread surface. Take a reading on both sides of the center tread and average the measurements. The greatest error in measuring idler tread wear arises from wear on the center flange which alters the reference point. If this wear is suspected, some attempt to compensate for it should be made in the reading taken. Remember idler tread wear measurements increase as tread wear occurs and decreases as center flange wear occurs.

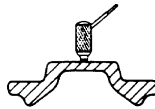

Center flange wear is measurable with the Ultrasonic Wear Indicator on fabricated and sound reduction idlers only. It measures the thickness of the center flange and should be taken directly in the center of the flange. Use the conventional depth gauge to measure wear on the tread surface, then add the center flange wear to the depth gauge measurement before determining percent worn.

### Wear Limits

Idler tread wear limits are based on two basic criteria: Rebuildability of the tread surface plus center flange to track bushing clearance. If the idler is worn beyond 110 percent the tread will become too thin to successfully rebuild.

### Wear Charts

Wear charts for idlers are direct reading from the measurement taken. They have a built-in factor allowing for faster wear rate after the hardened case depth is worn away. The wear rate is about three times as fast in the unhardened material below the case depth.

### Rebuildability

Idler tread and flange can be successfully rebuilt (welded) several times if they are not worn beyond service limits and if center flange wear is considered into this service point.

Welded idlers generally provide wear life equal to original tread wear life to respective limits if welded to original dimensions.

## Idlers

---

### Swapping Idlers

---

Idlers can be swapped from side to side or front to rear (on elevated sprocket machines) to balance wear. Consider swapping whenever the ratio of most worn to least worn is greater than 1.5 to 1 and the average percent worn is 45 to 55 percent.

Elevated sprocket machines where idlers cannot be swapped front to rear due to the idlers being a different diameter are listed below.

Machine Model:

D4H (std), D4H XL

D5N/M XL

D6H LGP (with large front idler)

D8N/R/T

---

### Idler Wear Patterns

---

Idler wear patterns can be used to help interpret abnormal wear causes on mating parts, track links, plus interpret other controllable and non-controllable accelerators, which may be affecting non-mating parts such as rollers which are harder to see and inspect.

The idler tread wear rate is very sensitive to tight track.

---

#### Tread Wear

Normal wear pattern



**Causes:** Sliding contact with the track link rail surface.

**Accelerators:** Tight track, impact, abrasiveness, turning, speed, and improper machine balance.

**Effects:** Idlers may wear out before other critical components.

**Remedies** Eliminate tight track and balance the machine as needed.

---

#### Flange Side Wear

**Causes:** Sliding contact with inside of track link rail.

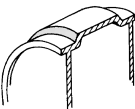

**Accelerators:** Operation on sidehills, wide shoes, turning, worn guards and misalignment with carrier roller or track roller. Reference topic "Alignment" under Controllable Variables.

**Effects:** Reduces idler tread rebuildability due to difficulty welding. Reduces wear life of the link.

**Remedies** Reduce or eliminate controllable accelerator.

---

#### Flange Top Wear

**Causes:** (1) Sliding contact with abrasive material or rocks packed into the idler area. (2) Contact with track links that have jumped out of tread area.



**Accelerators:** (1) Rocky underfoot conditions. (2) Loose track.

**Effects:** Reduces wear measurement distance and resulting accuracy. Reduces rebuildability in extreme cases.

**Remedies** Rebuild if critical. Install idler top guards or clean packed material from behind the idler. Correct the cause of links jumping out of tread.

---

---



---

## **Idler Position**

---

Some machines have two-position idlers that can be adjusted to provide either “high” or “low” idler position. With idlers in the “high” position, there is less track-to-ground contact area, but the machine is more maneuverable. With idlers in the “low” position there is more track-to-ground contact area and greater stability, but the machine is less maneuverable, vibration is greater, and wear life is reduced. Idlers should be adjusted to the “high” position except where the “low” position is necessary for machine stability. <sup>(1)</sup>

---

## **Idler Wear – Center Tread Idlers and Relieved Center Tread Idlers**

---

### **Measurement Technique**

Center Tread Idler tread wear is measured with the Ultrasonic Wear Indicator, Depth Gauge, or with the small caliper.

Relieved Center Tread Idler wear is measured with the Depth Gauge or with the small caliper. These cannot be measured with the Ultrasonic Wear Indicator.

Both Relieved Tread and Center Tread Idlers must be measured on the side of the idler with the part number.

To provide a measurement location, the side of the idler with the part number is either machined around the entire inside diameter or notched. Only the early version idlers were notched.

Relieved Tread and Center Tread Idlers must be measured on the machined or notched surface as indicated below. This is very close to the outside edge of the tread surface. Care must be exercised to not measure onto the radius.



For complete details on Relieved Tread idler wear and re-use guidelines, reference Special Instruction REHS7608.

### **Wear Limits**

Center Tread Idler allowable wear and resulting wear limits are based on the rebuildability of the idler.

If the idler is worn past 100 percent, the tread will become too thin to successfully rebuild. Note that Relieved Tread idlers are not rebuildable.

### **Wear Charts**

Relieved Tread and Center Tread Idlers wear at a slower rate than conventional idlers, and the wear rate will not increase as rapidly after the hardened case depth is worn away.

## Idlers

---

---

### Idler Wear – Center Tread Idlers and Relieved Center Tread Idlers (Cont'd.)

---

#### **Rebuildability**

Rebuildability of Center Tread Idlers is comparable to conventional idlers. The Relieved Center Tread Idlers are not rebuildable.

#### **Installation**

Note that only the part number side of the idler is machined or notched and that the part number side should be installed to face the outside of the machine.

---

#### **NOTE**

**For information regarding the D6K Sprocketed Center Tread Idlers, reference the Low Sprocket Machines Introduction section [on, page 288](#).**

---

## Carrier Roller Tread Wear

### Measurement Technique

Carrier roller tread wear may be measured with the large caliper or with the Ultrasonic Wear Indicator.

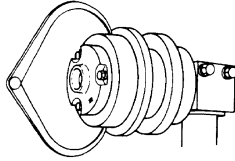

Position the caliper so the tips are touching the tread in its most worn position. Measurements should be made to the closest 0.01 inches (0.25 mm).

The Ultrasonic Wear Indicator measurement technique depends on the type of carrier roller being measured. On **carrier rollers with press-on rims**, as shown below, the thickness of the rim is measured, so find the location with the smallest reading.

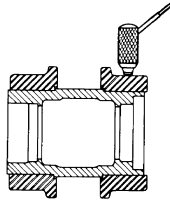

On **carrier rollers with one-piece rims**, the ultrasonic measurement is from the tread surface to the inside diameter of the roller. It is important to place the probe on the **outer** half of the tread surface on the side of the roller opposite the shaft as shown in the following illustration. Take caution because, due to the use of tapered roller bearings, more than one thickness can be found along each tread surface.

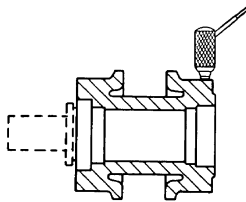

The Ultrasonic Wear Indicator may not accurately measure cast iron, so the carrier rollers on some machines may need to be measured with the caliper.

On **SystemOne carrier rollers**, the ultrasonic measurement is from the tread surface to the inside diameter of the roller. It is important to place the probe on the **inner** half of the tread surface on the side of the roller opposite the shaft as shown in the following illustration. Take caution because, due to the use of tapered roller bearings, more than one thickness can be found along each tread surface.

## Carrier Rollers

---

---

### Carrier Roller Tread Wear (Cont'd.)

---

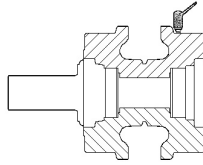

#### **Wear Limits**

Carrier roller wear limits are based on preventing flange interference with the track bushing.

#### **Wear Charts**

Wear charts for carrier rollers are a direct reading from the measurement. They have a built-in factor for higher wear rate after the hardened case is worn through. For some model sizes the hardened case covers the entire allowable wear so the expected wear rate is uniform.

#### **Swapping Carrier Rollers**

Carrier rollers can be swapped from front to rear and left to right to help balance their wear life in cases where conditions have caused unequal wear rates. Criteria are: greater than 1.5:1 ratio and the average percent worn is 50 to 60 percent.



---

## Carrier Roller Wear Patterns

---

There are three principle wear patterns found on carrier rollers. In each case the effect on the links may be more critical, considering total undercarriage life, than on the carrier rollers themselves.

### Tread Wear (Uniform)

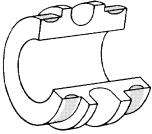

**Causes:** (1) Rolling and sliding contact with link rail and abrasives. (2) Sliding contact with packing material on roller frame.

**Accelerators:** Weight of track, which is affected by shoe width and packing material, and loose track.

**Effect:** Shortened wear life of carrier rollers and links.

**Remedies:** Maintain proper track tension and use narrow shoes.

---

### Uneven Flange Side Wear and Off-center Tread Wear

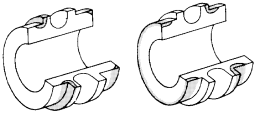

**Causes:** Rolling and sliding contact with link rail and sides due to misalignment.

**Accelerators:** Operation on side hills and misalignment of carrier rollers with sprockets and/or idlers.

**Effects:** Loss of wear life of carrier rollers and links.

**Remedies:** Correct any alignment problems. Swap carrier rollers to balance wear.

---

### Flat Spots on Tread

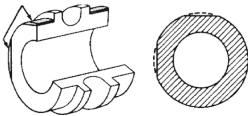

**Causes:** Sliding contact with link rail when carrier roller is not turning (seized).

**Accelerators:** Packing between track roller frame and carrier roller.

**Effect:** Reduced wear life of carrier rollers and links.

**Remedies:** Clean packing material away from carrier rollers.

---

# Track Rollers

---

---

## Roller Tread Wear

---

---

Track roller wear is the most difficult of all to measure and interpret. In some cases not all measurements will be possible due to guards.

### Tread Measurement Technique

Track roller tread wear can be determined by three methods, measuring tread diameter with a large caliper, flange height with a depth gauge, and rim thickness with an Ultrasonic Wear Indicator.

### Caliper Measurement

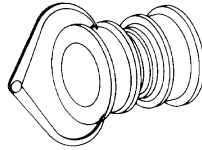

1. Position the caliper so the tips of the caliper are touching the tread in its most worn position on the diameter.
2. Pass the caliper back and forth to find the true minimum diameter.

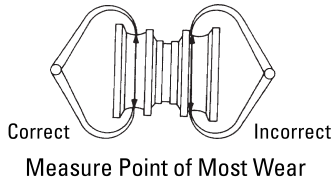
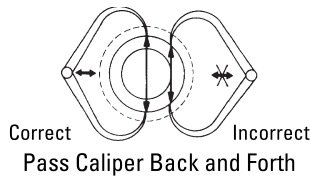

### Common Caliper Measurement Errors

1. Failure to clean surfaces before measurement will understate the amount of wear.
2. Failing to pass the calipers back and forth across the tread surface to find the true minimum diameter.
3. Failure to measure both outer and inner treads. This may tend to understate the effect of wear if the inner tread is more worn.
4. Over tightening calipers will result in an overstatement of wear due to the spring-back effect when calipers are removed from compression contact with the treads.

All these errors are similar to errors and results made when measuring track bushings.

---

## Roller Tread Wear (Cont'd.)

---

### Depth Gauge Measurement

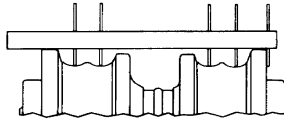

1. Set the farthest probe on the measurement tool as a reference hook on the outside of one flange. Then set the probes in the numbered holes for the model being measured.
2. On machines with elevated sprockets, the probes should be resting in the wear cusps on the roller tread. For all other machines the probes should be adjusted to the most worn surface.
3. Push the bar down flush with the flanges, then measure the exposed length of all tread probes and use the largest measurement (most worn position) to determine percent worn.

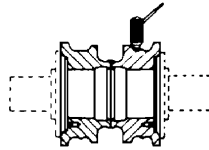

### Ultrasonic Wear Indicator Measurement

The Ultrasonic Wear Indicator measures the distance from the wear surface of the roller to the inside diameter of the roller.

It is important not to measure to the retainer bolt holes. On elevated sprocket machines and hydrostatic loaders with retainer rollers, observe the location of the retainer bolts and place the probe between them.

Most current track rollers are 'End Collar Rollers' that do not have retainer bolts, so measuring can be done anywhere on the surface of the roller.

On low sprocket track-type tractors, former track-type loaders, and excavators, the retainer bolts are not visible. For these rollers, observe the thickness readout closely from roller to roller to catch any abnormally small thicknesses which would indicate a reading to the bolt hole.

On track rollers with noticeable cusp wear, slide the probe across the cusp to get the smallest reading. To speed the process, select the cusp that normally is most worn (the cusp closer to the center of the roller), rather than sliding the probe over both cusps each time.

### Rear and Front Rollers Most Important

If roller guards or other conditions prevent measurement of all rollers, then the most important roller to be measured or estimate wear on is the rear roller. The next most important roller to be measured is the front roller. These two rollers should definitely be inspected by any means possible that does not present a safety hazard. The rear and/or front rollers generally will be most worn and therefore critical in maintenance decisions.

# Track Rollers

---

## Roller Tread Wear (Cont'd.)

---

### Wear Limits

Track roller wear limits are determined by setting the allowable wear equal to some fraction of the clearance between the link and the roller. On some machines this clearance is between the link pin boss and the roller flange. On other machines the clearance is between the bushing and the inner flanges of a double flange roller.

On a 100 percent worn link matched together with a 100 percent worn roller, the roller flanges are in contact with either the link pin bosses or the bushing.

### Wear Charts

Track roller wear charts have a built-in factor to account for expected faster wear rate after the hardened case depth is worn away.

Different wear charts are provided for different link-roller combinations where applicable and are identified by the link part number and roller description.

---

## Roller Wear Patterns

---

### Tread Wear

(Normal wear pattern)

**Causes:** (1) Rolling contact with abrasives crushed between roller tread and link rail. (2) Sideways sliding contact between link rail and roller tread.

**Accelerators:** Weight, machine speed, impact, abrasiveness, wide shoes. Machine application can cause unbalanced inner to outer tread and front to rear roller wear rate. Unusual roller frame distortion problems can accelerate selective wear rates. Turning increases sideways sliding contact.

**Effect:** Reduced wear life.

**Remedies:** Reduce or eliminate controllable accelerators, particularly machine balance, non-productive turning and wide shoes.

Swap rollers to balance final wear lives.

---

### Flange Side Wear

(Inner and/or outer sides)

**Causes:** Rolling and sliding contact with rail sides.

**Accelerators:** Side-hill operation, uneven terrain, turning, track roller frame misalignment, worn guiding guards and wide shoes.

**Effect:** Reduces the ability of track rollers to guide the track. Reduces the wear life of track links.

**Remedies:** Reduce or eliminate controllable accelerators.

---

### Flange Top Wear

**Causes:** Rolling and sliding contact with link pin bosses after loss of clearance.

**Effect:** Damages link pin bosses, which potentially results in the loss of pin retention and the ability to turn track.

**Remedies:** Replace worst track rollers or entire undercarriage system.

---

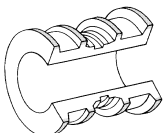
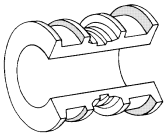
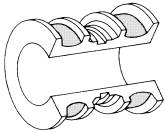

## Roller Welding, Swapping, or Replacement Guidelines

### Roller Swapping

Due to the unbalanced wear rate among track rollers, it's often desirable to swap rollers midway through their average wear lives. The result will be to increase the life of the track roller system, with most rollers reaching end of life at about the same time. To avoid downtime, roller swapping is frequently scheduled when pins and bushings are being turned.

The cost of roller swapping must be compared with the additional life to be achieved. Swapping should be considered when the percent worn of the most worn rollers exceeds the percent worn of the least worn rollers by a ratio of 1.3. To calculate this ratio, divide the percent worn of the least worn roller with the percent worn of the most worn roller.

Example of situation where roller swapping at bushing turn time should be considered:

#### LINKS: 40 percent worn ROLLERS:

ORIGINAL POSITION	% WORN	TYPE	MOVE TO POSITION NUMBER
Front (1)	50%	D.F.	4
2	40%	D.F.	No change
3	30%	S.F.	Rear (7)
4	30%	D.F.	Front (1)
5	40%	S.F.	No change
6	40%	D.F.	No change
Rear (7)	50%	S.F.	3

Average % Worn 40% (Same as Links)

The ratio of the two rollers that are being swapped is 1.66 (50/30). If the link projected life to 100% is 5,000 hours, then the roller projected life is 4,000 hours. Swapping the rollers will increase the life by 1,000 hours, reducing the cost per hour substantially.

If not swapped, front and rear rollers will be 100% worn when links are only 80% worn and pin boss to roller flange interference will occur when the links are 90% worn. If the rollers are swapped, both links and rollers will reach 100% worn at the same time.

### Swapping Rules

1. Swap rollers if the percent worn of the most worn exceeds the percent worn of the least worn by more than 1.3:1 ratio.
2. Swap rollers when the average percent worn is between 50% and 60%.
3. First swap the most worn with the least worn of same flange type; swap the second most worn with the second least worn of same flange type, etc.
4. Take advantage of swaps from left to right side of the machine.

#### NOTE

See other references to roller swapping guidelines specific to overall undercarriage management alternatives in the Management/Merchandising and Elevated Sprocket Tractor Section.

# Sprockets

---

## Sprocket Wear

It is recommended to replace sprocket segments at bushing turn time or link assembly replacement.

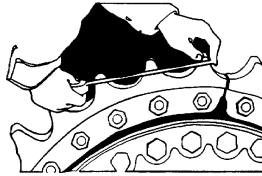

On elevated sprocket machines, sprocket wear is determined by measuring the distance across the tips of three sprocket teeth. Measure the distance between the drive side of one tooth tip and the opposite drive side of a sprocket tooth tip located three teeth away as shown in the illustration above. It is important to note that the distance measured should be between teeth on the same segment. Avoid measuring between teeth on different segments. Measurements for sprockets with less than 30% wear are unreliable and should be avoided.

---

## Sprocket Wear Patterns

---

These are the most common profile wear patterns found with Sealed and Sealed and Lubricated Track as identified in each case.

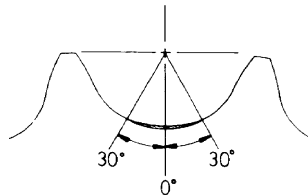

### Root Wear

(0° to 30° from vertical) is the normal wear pattern of Sealed and Lubricated Track on low sprocket machines.

**Causes:** Sliding contact with the bushing during forward to reverse direction changes and due to pitch mismatch from minor packing and advanced bushing wear.

**Accelerators:** Horsepower, weight, speed, impact, abrasiveness, tight track, packing and wide shoes.

**Effect:** None on sprocket itself.

**Remedies:** Eliminate or reduce controllable accelerators.

---

---

---

## Sprocket Wear Patterns (Cont'd.)

---

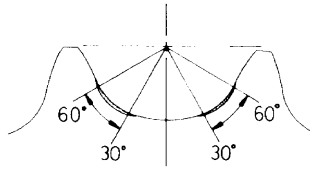

### Reverse Side Wear

(30° to 60° from vertical) is the normal wear pattern on elevated sprocket machines.

**Causes:** Sliding contact with the bushing.

**Accelerators:** Excessive reverse operation, tight track, packing and reverse operation up-hill.

**Effect:** Short wear life of sprockets.

**Remedies:** Eliminate tight track and minimize reverse operation.

---

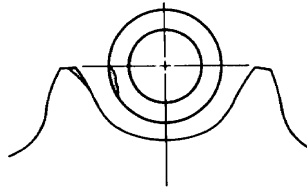

### Forward Drive Side (30° to 60° from vertical)

**Causes:** Contact with the bushing under load.

**Accelerators:** Tight track, Packing and worn bushings & sprockets.

**Effect:** Short wear life of sprockets.

**Remedies:** Eliminate tight track.

---

# Sprockets

---

## Sprocket Wear Patterns (Cont'd.)

---

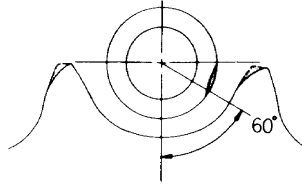

### Reverse Drive Side Tip Wear

**Causes:** Sliding contact with the bushing due to: (1) Severe packing. (2) On low sprocket machines track is too loose, causing "back jamming" at the bottom of the sprocket in reverse operation. Accompanied by bushing reverse drive side pocket wear.

**Note:**

To determine the cause of reverse drive side tip wear note the direction of the scratches on the tooth tip. If they point toward the tip then the cause is probably too loose track; if they point toward the root, the cause is probably severe packing.

**Accelerators:** Packing, uphill reverse loading of machine with loose track.

**Effect:** (1) Short wear life of bushings. (2) Track may jump over sprocket teeth if sprocket tooth tip height is worn excessively.

**Remedies:** Eliminate or reduce controllable accelerators. Do not change or replace segments based on tip wear alone.

---

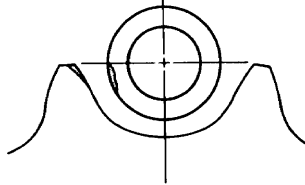

### Forward Drive Side Tip Wear

**Causes:** Sliding contact with the bushing due to packing material that causes sprocket pitch to be different from track pitch. Accompanied by bushing forward drive side pocket wear.

**Accelerators:** Packing.

**Effect:** Short wear life of bushings and track may jump over sprocket teeth if sprocket tooth tip height is worn excessively.

**Remedies:** Eliminate or reduce controllable accelerators. Do not change or replace segments based on tip wear.

---



---

## Sprocket Wear Patterns (Cont'd.)

---

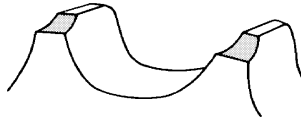

### Sprocket Side Wear and Corner Wear or Gouging

(Inner and/or Outer)

**Causes:** (1) If inner or outer side wear is on all sprocket teeth, principal cause is loss of guiding guard capability. (2) If limited to inner or outer, or not on all sprocket teeth, then principal cause is misalignment of sprocket with track roller frame.

**Accelerators:** Uneven terrain, side-hill operation, turning, wide shoes, misalignment, worn guiding guards.

**Effect:** Link, bushing and sprocket structural problems.

**Remedies:** Eliminate or reduce controllable accelerators.

---

## Mud & Snow Segments and Rims

---

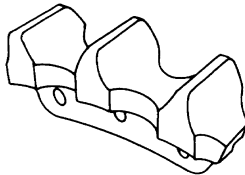

Mud & snow sprockets, rims and segments have the same tooth profile as standard segments. Through a slot cut into the tooth root, they provide an avenue to relieve extrudable packing material.

They should be recommended only where packing material is extrudable (see discussion on "Packing" in section entitled "Underfoot Conditions") and is always present.

In the absence of constant, extrudable packing material, the smaller contact area in the root of the tooth will reduce bushing wear life.

---

## How to Properly Torque Segment Hardware

---

The principal cause of segment loosening is improper tightening.

To install segment hardware, first, lubricate the bolt threads and the washer face of the nut with 5P-3931 Antiseize Compound or an equivalent lubricant.

Second, tighten all nuts on any one segment to the specified initial torque. This draws the mating parts tightly together.

Third, tighten each nut an additional 1/3 turn. This stretches the bolt properly for good segment retention.

The torque specifications can be found in the "Management" section of each type machine.

## Guards

---

### Guiding Guard Wear

---

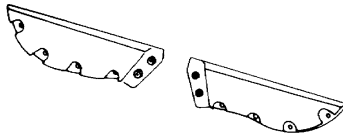

End and center guiding guards have no measurement technique, service limits or wear charts.

They should, however, be a part of every undercarriage inspection and their condition should be described.

Guiding guard wear on pin ends is a good indicator of guiding guard condition but should not be assumed to be the only indicator since wear strips might have been replaced since the track was first installed.

Guiding guard replaceable wear strips should be replaced before any wear or damage is done to the guard itself. The most convenient times to check and maintain guard wear strips is at pin and bushing maintenance and track replacement time.

---

### Need for Roller Guards

---



Full Roller Guard



Partial Roller Guard

Although roller guards (full or partial type) provide some track guiding, their purpose is to prevent structural damage caused by rocks, tree limbs, and other large material entering the roller areas.

Roller guards should be avoided in underfoot material that flows into the system. This is because roller guards tend to 'trap' abrasives in the undercarriage system, significantly reducing undercarriage life.

---

### Conditions for Use of Roller Guards

---

1. Rocks or gravel of 1 in. (25 mm) to 6 in. (150 mm).
2. Tree limbs, branches or other non-extrudable wood products or waste materials.
3. Sanitary landfill and demolition materials only if large metal, wood or other high strength objects of 1 in. to 6 in. (25 to 150 mm) in size are frequently encountered.

Remember, roller guards should only be used to keep foreign objects out, not for track guiding.

**The Disadvantages of using Roller Guards in the wrong conditions or for the wrong reasons include:**

1. **Difficulty in measuring, inspecting and maintaining rollers.**
2. **Reduces undercarriage wear life by keeping packing material in. Doesn't prevent material from entering the system.**
3. **May unnecessarily increase wear on link rail sides, pin bosses and on pin ends.**

---

## Introduction to Track Management

---

The link is the base or core component to which other components should be matched. Use the guidelines described below.

### Track management guidelines:

Match pin and bushing life with link life by turning or replacing bushings as needed.

- Match track roller life to link life by swapping rollers as needed.
- Match idler life to link life by swapping idlers as needed.
- Match shoe life to link life by regrousering or replacing as needed.
- Time these maintenance actions to achieve the lowest cost per hour while minimizing machine downtime.

---

## Wear Limits

---

The wear charts always display the wear measurements to 100% and 120%. The 100% point is considered the service/maintenance point. As shown on the table below, only a few components require maintenance.

The 120% wear point is frequently described as the destruction point. As a general guideline, the undercarriage may begin to fail or 'destruct' near this 120 percent wear point. However, the undercarriage (except for bushings) may operate well beyond 120 percent worn before 'destruction' actually occurs. This depends on several factors including application, underfoot conditions, past experience, and customer resistance to downtime.

When running to destruction, it is important to leave the parts on the machine as long as possible to minimize the cost per hour. Use the following guidelines when performing an undercarriage inspection near 120 percent worn to determine if the parts should continue to operate or be replaced.

## Maintenance

	Maintenance at 100% Worn
Link	None
Pins & Bushings	Turn
Rollers	None
Carrier Rollers	None
Idler	Rebuild (weld)
Sprocket	None
Shoe	Regrouser

## Destruction

Component	Failure Mode
Links	Cracking, pin and bushing loosening, pin boss damage
Bushings	Cracking
Shoes	Cracking, bending, loss of traction
Idlers	Cracking, damage to track bushings

## Track Management

### Wear Limits (Cont'd.)

#### Destruction (Cont'd.)

Component	Failure Mode
Carrier Rollers	Cracking, damage to track bushings
Track Rollers	Cracking, damage to track bushings, link pin bosses, and/or roller flanges

### Pin/Bushing to Link Ratio

The ratio of pin/bushing percent worn to link percent worn helps determine when and if to turn bushings. This ratio is calculated by dividing the percent worn of the pin/bushing (maximum of internal or external worn) by the percent worn of the track link. The goal is to minimize cost per hour by maximizing the life of the link assembly.

#### Pin/Bushing to Link Ratios

Pin/Bushing to Link % Worn Ratios	Actions to be Taken	
	Sealed Link Assembly	Sealed & Lubricated Link Assembly
Less than or equal to 1:1	Do not turn bushings.	Do not turn bushings.
Approximately 1.5:1	Turn bushings because pin and bushing life is less after turn.	Use CTS to determine the cost per hour with and without turning. If the decision is to turn bushings, turn between half of the link life to destruction and the bushing service point.
Approximately 2:1	Turn bushings at the pin/bushing service point.	Turn at the bushing service point.
Between 2:1 & 3:1	Turn bushings at the pin/bushing service point and consider replacing pins & bushings at the service point of the second side of the bushing. Use CTS to determine the cost per hour with and without pin & bushing replacement.	Turn bushings at the bushing service point and consider replacing bushings at the service point of the second side of the bushing. Use CTS to determine the cost per hour with and without bushing replacement. Determine if the cause of short bushing life can be remedied. Perhaps track tension is being run too tight.
Greater than or equal to 4:1	1. Turn, replace & turn at service points of pin or bushing. 2. Replace with Sealed and Lubricated Track.	See Above.

## Track Seal Replacement Recommendations

Good track seal maintenance practices assure maximum life for tracks. Use the following guidelines for determining when to replace track seals.

### Rigid Track Seals

All track-type machines with Sealed & Lubricated Track currently use Rigid Track Seals. This type of seal has excellent sealability, but its life is limited, eventually allowing oil to leak and joints to become dry. To maximize undercarriage life, replace these seals according to the intervals in the following chart.

### Post Turn Seals

This type of seal, introduced first on the D11, was designed for use during a pin & bushing turn or track reseal. Post Turn Seals are smaller in diameter than standard seals so that they seal against an unused bushing surface away from the original seal groove.

Use Post Turn Seals when bushing end grooving does not exceed the limit of the 4C-8613 (formerly 8T-9291) end grooving gauge. If bushing end grooving exceeds the limit of this gauge, replace the bushing using a new standard seal.

### Crescent Track Seals (noncurrent)

This type of seal provides adequate sealability. Reuse crescent seals because of established wear patterns between the seal and the end of the bushing.

Always reuse crescent track seals at bushing turn time.

### Elevated sprocket machines: D4H - D7R

### Low sprocket machines: D3 - D7G, 943 - 973 and 933 - 977

Projected Bushing Life to 100% Worn	Track Seal Recommendation <sup>(1)</sup>
0 to 2,000 SMU	<b>Reuse</b> seals during bushing turn.
2,000 to 4,000 SMU	<b>Replace</b> seals during bushing turn.
4,000 to 6,000 SMU	<b>Replace</b> seals at 4,000 SMU intervals.
	Consider turning bushings before 100% wear. <sup>(2)</sup>
6,000 SMU and greater	<b>Replace</b> seals at 4,000 SMU intervals.

1 EXCEPTION: When a bushing is replaced, always replace the seals used with that bushing.

2 The decision whether or not to turn bushings (versus reseal only) before 100% wear should depend on projected link life. For example, if projected link life for a D8T is less than 8,000 SMU, achieve full link life with a bushing turn at 4,000 SMU even if the bushings are only 50% worn. If projected link life is over 8,000 SMU, a cost per hour analysis should determine whether to turn bushings or to reseal at 4,000 SMU.

## Track Management

### Track Seal Replacement Recommendations (Cont'd.)

**Elevated sprocket machines: D8L - D11T (Except Sleeve Bearing Track)**  
**Low sprocket machines: D8 - D9H**

<b>Projected Bushing Life to 100% Worn</b>	<b>Track Seal Recommendation <sup>(3)</sup></b>
0 to 4,000 SMU	<b>Replace</b> seals during bushing turn.
4,000 to 6,000 SMU	<b>Replace</b> seals at 4,000 SMU intervals. Consider turning bushings before 100% wear. <sup>(4)</sup>
6,000 SMU and greater	<b>Replace</b> seals at 4,000 SMU intervals.

#### **D11N, D11R, D11T with Sleeve Bearing Track**

<b>Projected Bushing Life to 100% Worn</b>	<b>Track Seal Recommendation <sup>(3)</sup></b>
0 to 6,000 SMU	<b>Replace</b> seals during bushing turn.
6,000 to 8,000 SMU	<b>Replace</b> seals at 6,000 SMU intervals. Consider turning bushings before 100% wear. <sup>(4)</sup>
8,000 SMU and greater	<b>Replace</b> seals at 6,000 SMU intervals.

#### **NOTE**

Average track seal life is about 4,000 SMU, but life varies considerably depending on application and underfoot conditions. Actual seal life ranges from as low as 2,000 SMU to over 5,000 SMU. Generally, seal life will be shorter on machines working in severe conditions. To maximize pin & bushing life, around 3,500 SMU begin checking on a regular basis for dry joints. Resealing should be considered if joints become dry.

- 3 EXCEPTION: When a bushing is replaced, always replace the seals used with that bushing.
- 4 The decision whether or not to turn bushings (versus reseal only) before 100% wear should depend on projected link life. For example, if projected link life for a D8T is less than 8,000 SMU, achieve full link life with a bushing turn at 4,000 SMU even if the bushings are only 50% worn. If projected link life is over 8,000 SMU, a cost per hour analysis should determine whether to turn bushings or to reseal at 4,000 SMU.

## CTS Inspection Report

---

The Custom Track Service Inspection Report (PEEP7212, PFEP7212, PGEP7212, PSEP7212, PPEP7212) provides a convenient format for recording information and computed values that are important to report undercarriage condition to the user. It also acts as a history record of past conditions and recommendations. On the back of the form is a Recommendation Checklist and space for drawing two maintenance options.

### How to Fill-Out CTS Inspection Report <sup>(5)</sup>

1. **Customer and Machine Information**
2. **Component History** — This section should be filled in from history records prior to the inspection. It should reflect date(s) or meter reading(s) which will allow calculations of hours on the parts. Lines are provided next to the track roller positions to enter a flange type for each roller. Use "S" for single flange and "D" for double flange as installed on the machine.
3. **Inspection Information** — Meter reading is used to determine hours on parts. Hours per week is for expected future usage of the machine and is used for projecting dates to schedule alternative actions.

The notes section is for any additional information pertinent to the inspection which is not on this form. Major recommendations to the user may also be included on the reverse side of the CTS Inspection Form.

Record the measurement of each component to the closest 0.01 in.(0.1 mm) for the left and right side of the machine.

4. **Calculated Data** — Hours on Wear Surface is very important data and may be calculated by subtracting the hours installed from the current hour meter reading.

Percent Worn is obtained by using the measurement and the appropriate impact or allowable wear ratings from the wear chart portion of this handbook.

Total Potential Hours to 100% Worn are calculated by dividing the hours on wear surface by the percent worn. This will give the potential to the service limit assuming similar conditions. It may not be reliable using percent worn values less than 30 percent.

Total Potential Hours to 120% Worn are calculated by multiplying the total potential hours to 100% Worn by 1.2.

A line is provided to show the calculated average of track roller data. This line is used to determine track roller swapping considerations.

---

5 Refer to the example on the next page.

# Track Management

## CTS Inspection Report (Cont'd.)



CUSTOM  
TRACK  
SERVICE

### CTS INSPECTION REPORT

PREPARED BY \_\_\_\_\_

DEALER \_\_\_\_\_

NEXT INSPECTION DATE \_\_\_\_\_

Model _____ Serial Number _____ Equipment Number _____ Manufacturer _____ Customer Name <b>1</b> _____ Number _____ Location _____ Maintenance Date _____ Hour Meter Operative? Yes <input type="checkbox"/> No <input type="checkbox"/> Undercarriage Code _____ Undercarriage Brand _____	Inspection Date _____ Hour Meter Reading _____ Hours per Week _____ Odometer Reading _____ Job Site _____ Underfoot Conditions   Low   Mod.   High Impact <input type="checkbox"/> <input type="checkbox"/> <input type="checkbox"/> Abrasive <input type="checkbox"/> <input type="checkbox"/> <input type="checkbox"/> Moisture <input type="checkbox"/> <input type="checkbox"/> <input type="checkbox"/> Packing <input type="checkbox"/> <input type="checkbox"/> <input type="checkbox"/> Bushing Allowable Wear   Greater <input type="checkbox"/> Lesser <input type="checkbox"/> Track Sag                Left _____ Right _____ Frame Extension       Left _____ Right _____ Dry Joints               Left _____ Right _____	Notes _____ _____ _____ _____ _____ _____ _____ _____
---	---	--

COMPONENTS	SMR OR DATE INSTALLED Turned/ New   Welded	HOURS on Wear Surface **	TOOL USED	MEASUREMENT		% WORN		TOTAL POTENTIAL HOURS					
				Left	Right	Left	Right	To 100% Worn Left	To 100% Worn Right	To 120% Worn Left	To 120% Worn Right		
<b>LINKS</b> Part No. _____ No. of Sections _____			Depth <input type="checkbox"/> Sonic <input type="checkbox"/>										
<b>BUSHINGS</b> Internal <input type="checkbox"/> Sealed <b>2</b> <input type="checkbox"/> Sealed & Lubricated External <input type="checkbox"/> Rotating Bushing		<b>4</b>	Tape Caliper <input type="checkbox"/> Depth <input type="checkbox"/> Sonic <input type="checkbox"/>							<b>4</b>			
<b>SHOES</b> <input type="checkbox"/> M.S. <input type="checkbox"/> D.G. <input type="checkbox"/> E.S. <input type="checkbox"/> T.G. Width _____ <input type="checkbox"/> S.E.S. <input type="checkbox"/> _____			Depth <input type="checkbox"/> Sonic <input type="checkbox"/>										
<b>IDLERS</b> <input type="checkbox"/> Two Sizes Front Part No. _____ Rear Part No. _____			Depth <input type="checkbox"/> Sonic <input type="checkbox"/> Depth <input type="checkbox"/> Sonic <input type="checkbox"/>										
<b>CARRIER ROLLERS</b> Front Part Number 2 3			Caliper <input type="checkbox"/> Sonic <input type="checkbox"/>										
<b>TRACK ROLLERS</b> Position Type Front _____ 2 _____ Part Number 3 _____ 4 _____ Single Flange 5 _____ 6 _____ Double Flange 7 _____ 8 _____ 9 _____ 10 _____ Average			Depth <input type="checkbox"/> Caliper <input type="checkbox"/> Sonic <input type="checkbox"/>										
<b>SPROCKETS</b>			Tape										

PEEP7212-11

\*\* Hours on component wear surfaces required to accurately manage undercarriage.

CATERPILLAR INC.



The objective of CTS calculations is to project time remaining on components to their 100 percent worn (maintenance point) and/or 120 percent worn (destruction). Simply determining percent worn is only the first step. Projecting service points allows you to schedule downtime to increase machine availability and reduce the customer's cost per hour.

The sequence of steps to project service points is as follows:

1. Determine percent worn from charts in CTS Handbook.
2. Determine Hours on Wear Surface. Subtract the hour meter reading when the components were installed from the hour meter reading at the time of the inspection
3. Determine Total Potential Hours to 100% worn by dividing the Hours on Wear Surface by the percent worn:

**Example:**

$$\begin{aligned} 500 \text{ SMU now} \div .25 \text{ (25\% worn)} \\ = 2000 \text{ SMU} \\ \text{(total potential to 100\% worn)} \end{aligned}$$

4. Determine the potential hours to 120% worn by multiplying the Total Potential Hours to 100% worn times 1.2:

**Example:**

$$\begin{aligned} 2000 \times 1.2 = 2400 \text{ SMU} \\ \text{(total potential to 120\% worn)} \end{aligned}$$

5. Find the hours remaining on the part until it would reach its total potential by subtracting the Hours on Wear Surface:

**Example:**

$$\begin{aligned} 2000 - 500 = 1500 \text{ SMU} \\ \text{(remaining until 100\% worn)} \end{aligned}$$

**Example:**

$$\begin{aligned} 2400 - 500 = 1900 \text{ SMU} \\ \text{(remaining until 120\% worn)} \end{aligned}$$

6. Note the part with the lowest total potential or fewest hours left. Calculate the time in weeks or months until reinspection, maintenance, or replacement is needed.

## Using CTS Reports To Manage Undercarriage

---

In conjunction with the release of CTSi 1.0, you will notice improvements to the various CTS Reports options:

- Reports are now available in 'Detailed' and 'Simple' formats, and the Percent Worn report also includes a 'Graph' format.
  - Detailed reports display complete inspection data for all measured undercarriage components. These reports also display component part numbers and wear chart numbers.
  - Simple reports display a more condensed inspection summary, and an undercarriage system graphic with component labeling provides a good discussion tool for the PSSR and customer.
  - All reports now include conditional formatting to hi-lite in color the higher percent worn components data fields. Percent Worn 80-95% is displayed in Yellow; percent worn greater than 95% is displayed in Red. The PSSR has the option to alter these ranges in the CTSi Preferences.

# Using CTS Reports To Manage Undercarriage



Custom Track Service  
Percent Worn

MICHIGAN TRACTOR

County-Line Excavating

Prepared By: Richard J Welch

Phone Number

Cell Number

Model :	D5G XL	Hour Meter Reading :	8,371	Inspection Date :	6/5/2013
Manufacturer :	Caterpillar	Hours Per Week :	50	Next Inspection Date :	6/5/2013
Serial Number :	0FDH00607	Odometer Reading :		Next Inspection Hours :	
Equipment Number :		Forward Odometer Reading :		<u>Underfoot Conditions</u>	
Job Site :		Reverse Odometer Reading :		Impact :	Moderate
				Abrasion :	High
		Track Sag :	Left 1.90 Right 2	Moisture :	Moderate
			OK OK	Packing :	Low
		Frame Extension :		Bushing Allowable Wear :	Greater
		Maximum :		Link Allowable Wear :	Greater
		Dry Joints :			

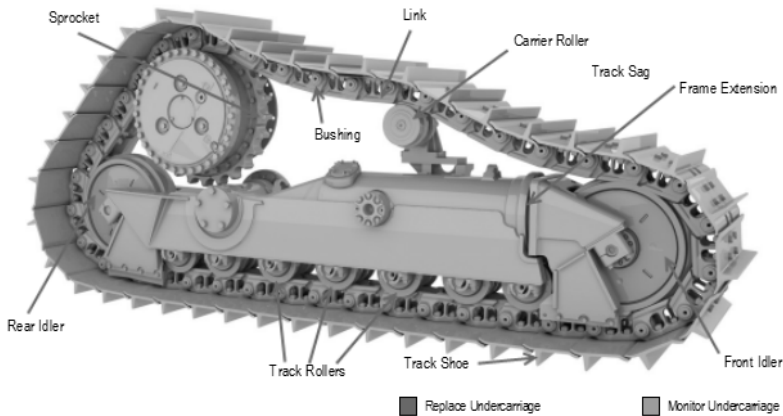

	Position	Status		Percent Worn	
		Left	Right	Left	Right
LINKS		Replaced	Replaced	30 %	30 %
BUSHINGS	External	Replaced	Replaced	64 %	66 %
SHOES		Replaced	Replaced	60 %	55 %
IDLERS	Front	Replaced	Replaced	76 %	82 %
CARRIER ROLLERS		Replaced	Replaced	96 %	93 %
TRACK ROLLERS	Worst	Replaced	Replaced	85 %	87 %
SPROCKETS		Replaced	Replaced	Fair	Fair

Notes : Plan to turn bushings no later than 9,000 SMU. At that time, also replace carrier rollers, weld idlers and consider replacing track rollers.

# Using CTS Reports To Manage Undercarriage



Custom Track Service

Percent Worn

MICHIGAN TRACTOR

County-Line Excavating

Prepared By: Richard J Welch

Phone Number :

Cell Number :

Model :	D5G XL	Hour Meter Reading :	8,371	Inspection Date :	6/5/2013
Manufacturer :	Caterpillar	Hours Per Week :	50	Next Inspection Date :	6/5/2013
Serial Number :	0FDH00607	Odometer Reading :		Next Inspection Hours :	
Equipment Number :		Forward Odometer Reading :		Last Service Date :	11/5/2012
Link Manufacturer :	Caterpillar	Reverse Odometer Reading :			
Roller Manufacturer :	Caterpillar	Job Site :		<u>Underfoot Conditions</u>	
Idler Manufacturer :	Caterpillar			Impact :	Moderate
		Track Sag :	Left 1.90 OK	Right 2 OK	Abrasion : High
		Frame Extension :		Moisture :	Moderate
		Maximum :		Packing :	Low
		Dry Joints :		Bushing Allowable Wear :	Greater
				Link Allowable Wear :	Greater

		Status		Date Installed		SMU Installed		Hours On Wear Surface		Measurement (Inches)		Percent Worn			
Position	Left	Right	Left	Right	Left	Right	Left	Right	Tool Used	Left	Right	Left	Right		
<b>LINKS (48)</b>		6Y9261		Sections : 39		Track Group :		Link Assembly : 2279960							
			6/20/2006	6/20/2006	7,044	7,044	1,327	1,327	Ultrasonic	0.98	0.98	30 %	30 %		
<b>BUSHINGS (642)</b>		2243959		Sealed and Lubricated											
External	Replaced	Replaced	11/5/2012	11/5/2012	7,044	7,044	1,327	1,327	Ultrasonic	0.29	0.28	64 %	66 %		
<b>SHOES (1243)</b>		8E9812		Master Shoes :		Moderate Service		Width : 20.08 (Inches)							
	Replaced	Replaced	6/20/2006	6/20/2006	4,178	4,178	4,193	4,193	Ultrasonic	1.70	1.75	60 %	55 %		
<b>IDLERS (4344)</b>		Front : 9L9055		Rear :		Conventional									
Front	Replaced	Replaced	6/20/2006	6/20/2006	4,178	4,178	4,193	4,193	Depth Gauge	0.86	0.90	76 %	82 %		
<b>CARRIER ROLLERS (4647)</b>		6K9880		Conventional											
Front	Replaced	Replaced	6/20/2006	6/20/2006	4,178	4,178	4,193	4,193	Caliper	5.36	5.40	96 %	93 %		
<b>TRACK ROLLERS (5244,5244)</b>		Single Flange : 1248237		Double Flange : 1248240											
	L	R													
Front	S	S	Replaced	Replaced	6/20/2006	6/20/2006	4,178	4,178	4,193	4,193	Ultrasonic	1.04	1.03	85 %	87 %
2	D	D	Replaced	Replaced	6/20/2006	6/20/2006	4,178	4,178	4,193	4,193	Ultrasonic	1.09	1.08	78 %	79 %
3	S	S	Replaced	Replaced	6/20/2006	6/20/2006	4,178	4,178	4,193	4,193	Ultrasonic	1.06	1.07	82 %	81 %
4	D	D	Replaced	Replaced	6/20/2006	6/20/2006	4,178	4,178	4,193	4,193	Ultrasonic	1.06	1.06	82 %	82 %
5	S	S	Replaced	Replaced	6/20/2006	6/20/2006	4,178	4,178	4,193	4,193	Ultrasonic	1.04	1.05	85 %	84 %
6	D	D	Replaced	Replaced	6/20/2006	6/20/2006	4,178	4,178	4,193	4,193	Ultrasonic	1.05	1.05	84 %	84 %
7	S	S	Replaced	Replaced	6/20/2006	6/20/2006	4,178	4,178	4,193	4,193	Ultrasonic	1.06	1.04	82 %	85 %
<b>SPROCKETS</b>		First : 1979677		Second : 1979678											
	Replaced	Replaced	6/20/2006	6/20/2006	4,178	4,178	0	0			Fair		Fair		

Notes : Plan to turn bushings no later than 9,000 SMU. At that time, also replace carrier rollers, veld idlers and consider replacing track rollers.

# Using CTS Reports To Manage Undercarriage

<b>CATERPILLAR</b>		Custom Track Service		<b>MICHIGAN TRACTOR</b>	
		<b>Percent Worn</b>			
<b>County-Line Excavating</b>		Prepared By: Richard J Welch	Phone Number:	Call Number:	
<b>Model:</b> D5G XL	<b>Hour Meter Reading:</b> 8,371	<b>Inspection Date:</b> 6/5/2013	<b>Underfoot Conditions</b>		
<b>Manufacturer:</b> Caterpillar	<b>Hours Per Week:</b> 50	<b>Next Inspection Date:</b> 6/5/2013	<b>Impact:</b> Moderate		
<b>Serial Number:</b> OFDH00607	<b>Odometer Reading:</b>	<b>Next Inspection Hours:</b>	<b>Abrasion:</b> High		
<b>Equipment Number:</b>	<b>Forward Odometer Reading:</b>	<b>Last Service Date:</b> 11/5/2012	<b>Moisture:</b> Moderate		
<b>Link Manufacturer:</b> Caterpillar	<b>Reverse Odometer Reading:</b>	<b>Left:</b>	<b>Right:</b>	<b>Packing:</b> Low	
<b>Roller Manufacturer:</b> Caterpillar	<b>Job Site:</b>	<b>Track Sag:</b> 1.90	<b>2.00</b>	<b>Bushing Allowable Wear:</b> Greater	
<b>Idler Manufacturer:</b> Caterpillar		<b>OK</b>	<b>OK</b>	<b>Link Allowable Wear:</b> Greater	
		<b>Frame Extension:</b>			
		<b>Maximum:</b>			
		<b>Dry Joints:</b>			

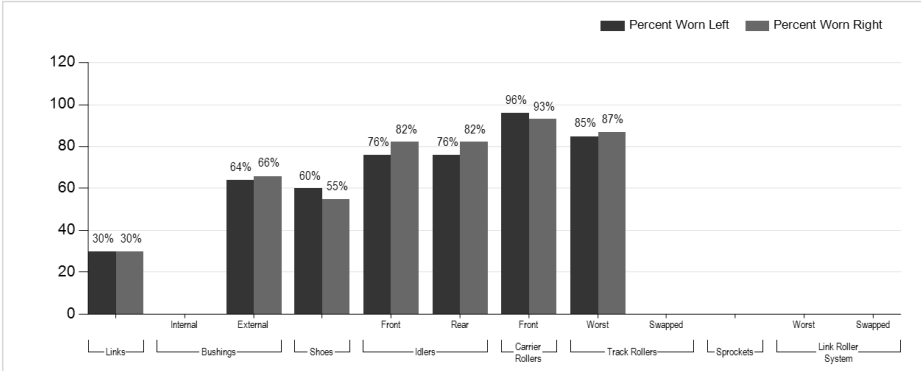

Notes: Plan to turn bushings no later than 9,000 SMU. At that time, also replace carrier rollers, weld idlers and consider replacing track rollers.

The CTS Percent Worn report, shown above in “Simple”, “Detailed”, and “Graph” format options, is the most commonly used report. This is an excellent report to share with customers to give them a status report on a machine’s undercarriage. This report is not intended to be the single source of information when attempting to manage undercarriage.

Problems with using this report to manage undercarriage include:

- If components are replaced at different times, the percent worn values cannot be compared. On this report, for example, the link assemblies were replaced more recently than the other components.
- Some components need maintenance at 100% worn (turn bushings) while others need to be replaced at 120% worn (carrier rollers). This makes it difficult to compare the percent worn values for different components.
- These problems commonly cause PSSRs to measure undercarriage more often than necessary to check on the status of the undercarriage.

# Using CTS Reports To Manage Undercarriage



Custom Track Service

## Projected Hour Meter Reading

MICHIGAN TRACTOR

### County-Line Excavating

Prepared By: Richard J Welch

Phone Number :

Cell Number :

Model :	DSG XL	Hour Meter Reading :	8,371	Inspection Date :	6/5/2013
Manufacturer :	Caterpillar	Hours Per Week :	50	Next Inspection Date :	6/5/2013
Serial Number :	0FDH00607	Odometer Reading :		Next Inspection Hours :	
Equipment Number :		Forward Odometer Reading :		Last Service Date :	11/5/2012
Link Manufacturer :	Caterpillar	Reverse Odometer Reading :			
Roller Manufacturer :	Caterpillar	Job Site :		<u>Underfoot Conditions</u>	
Idler Manufacturer :	Caterpillar			Impact :	Moderate
		Track Sag :	Left 1.90 Right 2	Abrasion :	High
			OK OK	Moisture :	Moderate
		Frame Extension :		Packing :	Low
		Maximum :		Bushing Allowable Wear :	Greater
		Dry Joints :		Link Allowable Wear :	Greater

Position	Status		Hours On Wear		Tool Used	Measurement (Inches)		Percent Worn		Projected Hour Meter Reading					
	Left	Right	Left	Right		Left	Right	Left	Right	100 %		120 %			
<b>LINKS (48)</b>		6Y9261		Sections : 39		Track Group :		Link Assembly : 2279960							
			1,327	1,327	Ultrasonic	0.98	0.98	30 %	30 %	11,467	11,467	12,351	12,351		
<b>BUSHINGS (642)</b>				2243959		Sealed and Lubricated									
External	Replaced	Replaced	1,327	1,327	Ultrasonic	0.29	0.28	64 %	66 %	9,117	9,055	9,531	9,457		
<b>SHOES (1243)</b>		8E9812		Master Shoes :		Moderate Service		Width : 20.08 (Inches)							
	Replaced	Replaced	4,193	4,193	Ultrasonic	1.70	1.75	60 %	55 %	11,166	11,802	12,563	13,326		
<b>IDLERS (4344)</b>		Front : 9U9065		Rear :		Conventional									
Front	Replaced	Replaced	4,193	4,193	Depth Gauge	0.86	0.90	76 %	82 %	9,685	9,291	10,798	10,313		
<b>CARRIER ROLLERS (4647)</b>				6K3880		Conventional									
Front	Replaced	Replaced	4,193	4,193	Caliper	5.36	5.40	96 %	93 %	8,546	8,687	9,419	9,588		
<b>TRACK ROLLERS (5244,5244)</b>				Single Flange : 1248237		Double Flange : 1248240									
	L	R													
Front	S	S	Replaced	Replaced	4,193	4,193	Ultrasonic	1.04	1.03	85 %	87 %	9,111	8,998	10,097	9,962
2	D	D	Replaced	Replaced	4,193	4,193	Ultrasonic	1.09	1.08	78 %	79 %	9,554	9,486	10,629	10,547
3	S	S	Replaced	Replaced	4,193	4,193	Ultrasonic	1.06	1.07	82 %	81 %	9,291	9,355	10,313	10,390
4	D	D	Replaced	Replaced	4,193	4,193	Ultrasonic	1.06	1.06	82 %	82 %	9,291	9,291	10,313	10,313
5	S	S	Replaced	Replaced	4,193	4,193	Ultrasonic	1.04	1.05	85 %	84 %	9,111	9,170	10,097	10,168
6	D	D	Replaced	Replaced	4,193	4,193	Ultrasonic	1.05	1.05	84 %	84 %	9,170	9,170	10,168	10,168
7	S	S	Replaced	Replaced	4,193	4,193	Ultrasonic	1.06	1.04	82 %	85 %	9,291	9,111	10,313	10,097
<b>SPROCKETS</b>				First : 1979677		Second : 1979678									
	Replaced	Replaced	0	0		Fair				Fair					

Notes : Plan to turn bushings no later than 9,000 SMU. At that time, also replace carrier rollers, weld idlers and consider replacing track rollers.

The CTS Hour Meter Reading report shown above in "Detailed" format, from the CTS computer program, is probably the most valuable report for managing undercarriage. On the right side of the page the hour meter reading is projected for each component to 100% and 120%. Reference the 120% projection for components that will be replaced (links, rollers, sprockets) and 100% for components to be serviced (bushings, shoes, idlers).

Find the first component requiring service or replacement. For this machine that component is the right side bushing at an hour meter reading of 9,055. Next determine if other components should be serviced at the same time. Perhaps the carrier rollers should be replaced, idlers should be welded. If the customer wants to avoid additional downtime, the track rollers could be replaced.

Estimate the date of the service by subtracting the projected hour meter reading of the bushing from the current hour meter reading then dividing the result by the hours per week. For this

# Using CTS Reports To Manage Undercarriage

machine, subtracting 8,371 from 9,055 then dividing the result (684 hours) by 50 hours per week gives us 12 weeks (three months).

Advantages of using this report to manage undercarriage include:

- The PSSR and customer have an expectation (the projected hour meter reading) as to when the next maintenance is to be expected.
- Grouping of maintenance points is simplified.
- An estimated date of the next service or next inspection can be calculated.

<b>CATERPILLAR®</b>	Custom Track Service <b>Remaining Life</b>	<b>MICHIGAN TRACTOR</b>
<b>County-Line Excavating</b>		Prepared By: Richard J Welch      Phone Number : Cell Number :
<b>Model :</b> D5G XL	<b>Hour Meter Reading :</b> 8,371	<b>Inspection Date :</b> 6/5/2013
<b>Manufacturer :</b> Caterpillar	<b>Hours Per Week :</b> 50	<b>Next Inspection Date :</b> 6/5/2013
<b>Serial Number :</b> 0FDH00607	<b>Odometer Reading :</b>	<b>Next Inspection Hours :</b>
<b>Equipment Number :</b>	<b>Forward Odometer Reading :</b>	<b>Last Service Date :</b> 11/5/2012
<b>Link Manufacturer :</b> Caterpillar	<b>Reverse Odometer Reading :</b>	
<b>Roller Manufacturer :</b> Caterpillar	<b>Job Site :</b>	<u>Underfoot Conditions</u>
<b>Idler Manufacturer :</b> Caterpillar		
	<u>Left</u> <u>Right</u>	<b>Impact :</b> Moderate
<b>Track Sag :</b>	1.90      2	<b>Abrasion :</b> High
	OK      OK	<b>Moisture :</b> Moderate
<b>Frame Extension :</b>		<b>Packing :</b> Low
<b>Maximum :</b>		<b>Bushing Allowable Wear :</b> Greater
<b>Dry Joints :</b>		<b>Link Allowable Wear :</b> Greater

Position	Status		Hours On Wear				Measurement (Inches)		Percent Worn		Remaining Life				
	Left	Right	Surface		Tool Used	Left	Right	Left	Right	100 %		120 %			
<b>LINKS (48)</b>	6Y9261		Sections : 39				Track Group :		Link Assembly : 2279960						
			1,327	1,327	Ultrasonic	0.98	0.98	30 %	30 %	3,096	3,096	3,980	3,980		
<b>BUSHINGS (642)</b>			2243959				Sealed and Lubricated								
External	Replaced	Replaced	1,327	1,327	Ultrasonic	0.29	0.28	64 %	66 %	746	684	1,160	1,086		
<b>SHOES (1243)</b>	8E9812		Master Shoes :				Moderate Service		Width : 20.08 (Inches)						
	Replaced	Replaced	4,193	4,193	Ultrasonic	1.70	1.75	60 %	55 %	2,795	3,431	4,192	4,965		
<b>IDLERS (4344)</b>	Front : 9L9065		Rear :				Conventional								
Front	Replaced	Replaced	4,193	4,193	Depth Gauge	0.86	0.90	76 %	82 %	1,324	920	2,427	1,942		
<b>CARRIER ROLLERS (4647)</b>	6K9880						Conventional								
Front	Replaced	Replaced	4,193	4,193	Caliper	5.36	5.40	96 %	93 %	175	316	1,048	1,217		
<b>TRACK ROLLERS (5244,5244)</b>			Single Flange : 1248237				Double Flange : 1248240								
	L	R													
Front	S	S	Replaced	Replaced	4,193	4,193	Ultrasonic	1.04	1.03	85 %	87 %	740	627	1,726	1,591
2	D	D	Replaced	Replaced	4,193	4,193	Ultrasonic	1.09	1.08	78 %	79 %	1,183	1,115	2,258	2,176
3	S	S	Replaced	Replaced	4,193	4,193	Ultrasonic	1.06	1.07	82 %	81 %	920	984	1,942	2,019
4	D	D	Replaced	Replaced	4,193	4,193	Ultrasonic	1.06	1.06	82 %	82 %	920	920	1,942	1,942
5	S	S	Replaced	Replaced	4,193	4,193	Ultrasonic	1.04	1.05	85 %	84 %	740	799	1,726	1,797
6	D	D	Replaced	Replaced	4,193	4,193	Ultrasonic	1.05	1.05	84 %	84 %	799	799	1,797	1,797
7	S	S	Replaced	Replaced	4,193	4,193	Ultrasonic	1.06	1.04	82 %	85 %	920	740	1,942	1,726
<b>SPROCKETS</b>			First : 1979677				Second : 1979678								
	Replaced	Replaced	0	0				Fair				Fair			

Notes : Plan to turn bushings no later than 9,000 SMU. At that time, also replace carrier rollers, weld idlers and consider replacing track rollers.

The CTS Remaining Life report shown above in "Detailed" format, from the CTS computer program, is another valuable report for managing undercarriage. On the right side of the page the remaining life is projected for each component to 100% and 120%. Reference the 120% projection for

## Using CTS Reports To Manage Undercarriage

---

components that will be replaced (links, rollers, sprockets) and 100% for components to be serviced (bushings, shoes, idlers).

Find the first component requiring service or replacement. For this machine that component is the right side bushing, with a remaining life of 684 hours. Next determine if other components should be serviced at the same time. Perhaps the carrier rollers should be replaced, idlers should be welded. If the customer wants to avoid additional downtime, the track rollers could be replaced.

Estimate the date of the service by dividing the remaining life by the hours per week. For this machine, dividing 684 hours by 50 hours per week gives us 12 weeks (three months).

Advantages of using this report to manage undercarriage include:

- The PSSR and customer have an expectation (the remaining hours) as to when the next maintenance is to be expected.
- Grouping of maintenance points is simplified.
- Estimating the date of the next service or next inspection is easy.



# Using CTS Reports To Manage Undercarriage



Custom Track Service

**Projected Life**

**MICHIGAN TRACTOR**

**County-Line Excavating**      Prepared By: Richard J Welch      Phone Number      Cell Number

Model :	D5G XL	Hour Meter Reading :	8,371	Inspection Date :	6/5/2013
Manufacturer :	Caterpillar	Hours Per Week :	50	Next Inspection Date :	6/5/2013
Serial Number :	0FDH00607	Odometer Reading :		Next Inspection Hours :	
Equipment Number :		Forward Odometer Reading :		<u>Underfoot Conditions</u>	
Job Site :		Reverse Odometer Reading :			
		Left      Right		Impact :	Moderate
		Track Sag :	1.90      2	Abrasion :	High
			OK      OK	Moisture :	Moderate
		Frame Extension :		Packing :	Low
		Maximum :		Bushing Allowable Wear :	Greater
		Dry Joints :		Link Allowable Wear :	Greater

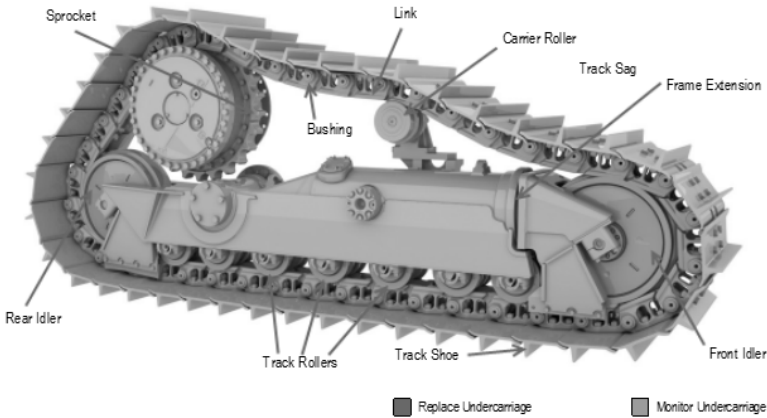

	Position	Status		Percent Worn		Projected Life 100 %		Projected Life 120 %	
		Left	Right	Left	Right	Left	Right	Left	Right
<b>LINKS</b>		Replaced	Replaced	30 %	30 %	4,423	4,423	5,307	5,307
<b>BUSHINGS</b>	External	Replaced	Replaced	64 %	66 %	2,073	2,011	2,487	2,413
<b>SHOES</b>		Replaced	Replaced	60 %	55 %	6,988	7,624	8,385	9,148
<b>IDLERS</b>	Front	Replaced	Replaced	76 %	82 %	5,517	5,113	6,620	6,135
<b>CARRIER ROLLERS</b>		Replaced	Replaced	96 %	93 %	4,368	4,509	5,241	5,410
<b>TRACK ROLLERS</b>	Worst	Replaced	Replaced	85 %	87 %	4,933	4,820	5,919	5,784
<b>SPROCKETS</b>		Replaced	Replaced				Fair		Fair

Notes : Plan to turn bushings no later than 9,000 SMJ. At that time, also replace carrier rollers, weld idlers and consider replacing track rollers.

The CTS Projected Life report shown above in "Simple" format, from the CTS computer program, is another useful report for managing undercarriage. On the right side of the page the projected life is displayed for each component to 100% and 120%. This report is valuable in estimating the life advantage of alternate maintenance options. Some analyses include:

- How many additional hours will the link assembly get if bushings are turned?
- How many additional hours will the undercarriage run if track rollers are swapped?
- How many additional hours will the undercarriage run if idlers are swapped?

To estimate the additional hours from turning bushings, add the bushing life to 120% (2,413) to the life to 100% (2,011) and compare that to the link life to 120% (5,307). Both sides of the bushing will

## Using CTS Reports To Manage Undercarriage

---

get 4,424 hours. This is less than the link life, so the additional life is bushing life to 100%, 2,011 hours. Using this value with the cost of the turn will allow an estimation of the cost per hour of that maintenance.

To estimate the additional hours from swapping track rollers, just compare the Link Roller System life worst and swapped. For this machine, this value is not calculated by CTS because the links and track rollers were not installed at the same time.

The advantage of using this report to manage undercarriage is the ability to estimate the value of alternative maintenance options.

You're a Product Support Representative visiting a customer about undercarriage management. The customer understands the high quality of Cat undercarriage, but needs to be convinced that it represents a greater value than competitive undercarriage. The computerized version of Custom Track Service can help. This software program helps you and the customer make informed decisions by calculating percent worn, projecting life, and estimating the cost per hour of various options.

### **How It Works**

You can measure and store up to 100 machines at a time with the Ultrasonic Wear Indicator IV, then plug a cable into your laptop computer and download all the measurements into the computer program. It takes about 1 second per machine.

The program is designed for field or office use, at a customer location or in a dealer office. It was built to provide integration with your dealer business system.

Numerous reports, including Custom Track Service forms and graphs can be printed for or e-mailed to customers to help them understand the value and professionalism of your services. The program will calculate the expected life of the undercarriage, using wear charts from the CTS Handbook.

### **Features**

- Provides multiple report options.
- Prints a Fleet Summary report.
- Stores virtually unlimited number of machines, inspections and service histories.
- Maintains a callback schedule for future undercarriage inspections.
- Eliminates manual entry of data by importing directly from the Ultrasonic Wear Indicator.
- Improves quality and reduces time by exporting previous inspections to the Ultrasonic Wear Indicator.
- Allows you to compare various maintenance alternatives so you can identify the lowest cost per hour.
- Screens are available in English, French, German, Portuguese, Spanish, and Japanese.

### **To Order**

Dealer License: JMRC7100

# Competitive Machine Undercarriage Conversion

---

Conversion to Caterpillar undercarriage is a commonly accepted practice among many owners of competitive track-type tractors, loaders and excavators.

---

## Why Consider Undercarriage Conversion?

---

Customers convert to Cat undercarriage for many reasons including:

- Lower cost per hour
- Dealer Undercarriage Management Program (CTS)
- Caterpillar product innovations
- Consistent parts quality
- Expertise of Caterpillar dealer
- Full quality repair, service
- Unmatched parts availability
- Caterpillar dealer is their One Safe Source for undercarriages
- Better parts price than many OEMs

Converting a machine to Cat undercarriage can be as simple as wrap-ping a track group on the competitive machine, or as extensive as changing the track, sprocket and rolling components. Some competitive machines require no modification at all while a few require extensive modification. (Reference IRM UC96-12)

---

## Determining Basic Convertibility In The Field

---

**Basic convertibility** is defined as installing a Cat track group with minimum, if any, modification to the machine. This may or may not require a change to Cat sprockets. Basic convertibility can be quickly and easily determined in the field using only four measurements.

### Track Group Convertibility

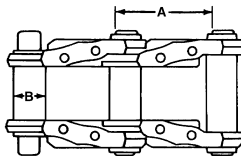

#### Measure

- A. — Pitch
- B. — Bushing O.D.

#### Result

These two dimensions determine if change to Cat sprocket is required.

## Determining Basic Convertibility In The Field (Cont'd.)

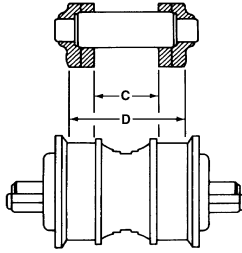

### Measure

C. — Inside Rail Spread

D. — Outside Rail Spread

### Result

These two dimensions determine if change to Cat rolling components is required.

Pitch may vary by  $\pm 0.03$  in. (0.8 mm) and the Cat bushing O.D. may be smaller by 0.12 in. (3 mm). Rail spreads must fit within outside roller flanges and clear inside flange if double flange rollers are used.

## Sprocket Convertibility

If change to Cat sprocket is necessary or desirable, a weld-on rim or adapter is required. Overall tip diameter and weld surface diameter available should be measured.

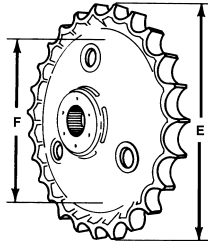

### Measure

E. — Tip Diameter

F. — Weld Surface

### Result

This dimension determines appropriate Cat adapter or rim.

This dimension helps determine if adequate material is available to weld on Cat rim or adapter.

Overall diameter of Cat sprocket (E) must clear competitive machine roller frame, guards, etc. Weld surface diameter (F) must allow for cutting competitive machine hub to appropriate Cat rim or adapter weld dimension. Care should be taken to assure sprocket remains in line with rollers when converting to Cat segments or rims.

# **Competitive Machine Undercarriage Conversion**

---

---

## **Track Roller, Carrier Roller and Idler Convertibility**

---

If change to Cat track roller and/or other rolling components is either necessary or desirable, some component removal may be required to obtain accurate measurements for comparison to Cat dimensions. Modification to the mounting bolt holes or the track roller end collars may be required.

For further details on conversion procedure and modification, refer to the following conversion information source:

Undercarriage Report  
Form/Worksheet  
IRM UC96-12

PEEP0210

## Introduction

The D8T through D11T use an exclusive undercarriage design to increase machine productivity and improve serviceability. The bogie mounted rollers and idlers allow for better traction, reduced impact loading and a better ride. The result is greatly increased productivity.

Elevated sprockets on D4H through D11T remove the final drives from abrasives and damaging implement loads. Final drive life has doubled and steering clutch/brake life has nearly tripled. Final drive repair times are shorter because roller frames do not have to be removed. For example, D9L final drive modules can be removed and installed in only five hours versus 45 hours on a D9H or Komatsu D355.

This innovative design results in undercarriage wear patterns different from those found on low sprocket track-type tractors. Different wear patterns require different management guidelines. These guidelines are reviewed on the following pages.

## Link Assembly Identification Code Markings

A uniform identification marking system has been adopted to improve follow-up reporting and warranty tracking of link assembly performance. For all models, locate the second full link from the bushing end (prior to 1991, the pin end) of the master link. The identification code is stamped on the shoe pad surface on the right hand link (as viewed during track press work).

The code is alphanumeric (eg. AC210Y04). For details of code interpretation see IRM PELJ0151.

## Undercarriage Identification

The easiest way to identify track is to read the part number forged into the link. The following list cross references link part numbers to the wear chart pages.

Model	Pitch	Link Part Number	Wear Chart Pages
D4H D5M, D5N 561H, 561M, 561N	6.75 in. (171.5 mm)	235-2514 108-0947 & 48 6Y-9261 & 62	<a href="#">From, page 107</a> – <a href="#">To, page 130</a>
D5H, D5R D6M, D6N 517	7.50 in. (190 mm)	235-2501 229-6909 & 10 106-1625 & 26 6Y-9267 & 68 417-3595 & 96	<a href="#">From, page 131</a> – <a href="#">To, page 154</a>
D6H, D6R, D6T 527	8.00 in. (203.2 mm)	234-9699 228-2735 & 36 195-6515 & 16 8E-7405 & 06 8E-2355 & 56 378-8241 & 42 418-2091 & 92	<a href="#">From, page 155</a> – <a href="#">To, page 182</a>
D7H, D7R 572R	8.50 in. (215.9 mm)	225-4789 & 90 6I-9239 & 40 9G-2417 & 18 289-3083 & 84 422-2659 & 60	<a href="#">From, page 184</a> – <a href="#">To, page 207</a>
D8N, D8R D8T	8.58 in. (218 mm)	304-5680 260-0300	<a href="#">See, page 209</a>
D8L, D8N D8R, D8T	8.50 in. (215.9 mm)	8E-4505 & 06 8E-4513 & 14	<a href="#">From, page 210</a> –

## Introduction

<b>Model</b>	<b>Pitch</b>	<b>Link Part Number</b>	<b>Wear Chart Pages</b>
578, 583R, 583T, 587T, PL83, PL87		391-3943 & 44	<a href="#">To, page 226</a>
D9N, D9R D9T	9.45 in. (240 mm)	7T-2275 & 26 9W-2743 & 44	<a href="#">From, page 227 – To, page 236</a>
D9L 589	9.00 in. (228.6 mm)	7T-7629 & 30 7T-4137 & 38	<a href="#">From, page 237 – To, page 244</a>
D10N, D10R D10T	10.25 in. (260.4 mm)	7T-0715 & 16 9W-5265 & 66 9W-5933 & 34 320-3053 & 54	<a href="#">From, page 245 – To, page 254</a>
D10	10.25 in. (260.4 mm)	9W-5723 & 24 9W-5933 & 34	<a href="#">From, page 255 – To, page 262</a>
D11N, D11R, D11T	12.50 in. (317.5 mm)	200-6325 & 26 6T-8049 & 50 320-3541 & 42	<a href="#">From, page 263 – To, page 280</a>



## Variables That Affect Wear Life

See the following pages for details on the effects of:

	<b>Page</b>
Controllable Variables	<a href="#">See, page 10</a>
Track Adjustment	<a href="#">See, page 10</a>
Shoe Width	<a href="#">See, page 11</a>
Alignment	<a href="#">See, page 13</a>
Non-Controllable Variables	<a href="#">See, page 17</a>
Soil & Underfoot Conditions	<a href="#">See, page 17</a>
Environmental Variables	<a href="#">See, page 19</a>
Partially Controllable Variables	<a href="#">See, page 22</a>

## Sealed and Lubricated Track

Sealed and Lubricated Track is used exclusively on the elevated sprocket tractors because internal pin and bushing wear, found in Sealed Track, would be accelerated on these models.

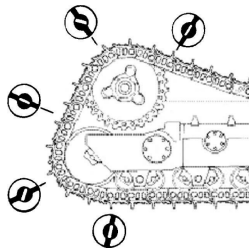

On low sprocket track-type tractors with Sealed Track, internal pin and bushing wear occurs in one position. The elevated sprocket design has three positions where internal pin and bushing wear would occur if it used Sealed Track. Sealed and Lubricated Track reduces internal pin and bushing wear as a maintenance consideration. The only time internal pin and bushing wear can occur is when a track joint loses its lubricant. If a track joint goes dry on a machine with elevated sprockets, internal pin and bushing wear may soon become critical. Therefore, on the elevated sprocket tractors, we recommend that operators inspect the track weekly for dry joints. [See, page 90](#) for the proper procedure.

## Components

---

---

### Links

---

See, [page 24 through, page 30](#) for detailed link information.

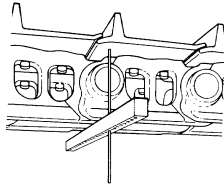

**Measurement** — Measure the track link over the centerline of the pin and bushing bores. See, [page 24](#) for details.

**Link Allowable Wear** — Two-level allowable wear percent worn charts are provided for the D8 through D11. The Greater Allowable Wear column should be used for nearly all applications except when link cracking due to structural fatigue has been experienced or suspected. If link cracking has been experienced then use the Lesser Allowable Wear column located in the rear of the elevated sprocket machine wear chart section.

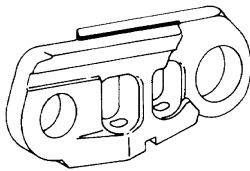

**Wear Patterns** — The undercarriage design of elevated sprocket machines and the absence of “snakiness” in Sealed and Lubricated Track allow it to “track” very straight. This straight tracking causes the roller to wear with a slight ridge running down the center of the tread. This ridge results from less wear occurring on the center of the roller tread as it passes over the links in their overlap area. The ridge on the roller may in turn wear a groove down the center of the link rail. This wear pattern is normal for these machines. It may occur less often on machines with non-suspended undercarriage. D9T, D10T, and D11T machines with improved alignment undercarriage also minimize or eliminate this wear pattern.

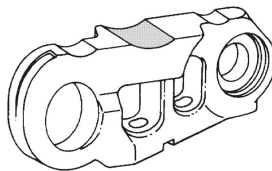

As elevated sprocket undercarriage wears, a larger scallop develops over the link strut than on oval undercarriage machines. This is because the track link goes around two idlers instead of one. This wear is not considered critical. Evaluate link wear based on wear directly over the pin area.

**Split Master Links** — Use the assembly procedures for [Split Master Link, page 28](#). For bolt torque specifications, [refer to, page 90](#).

---

## Pins and Bushings

---

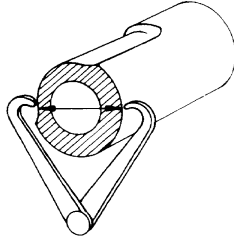

Elevated Sprocket Machines use Sealed and Lubricated Track. [See, page 31 through, page 38](#) for details. The following points are specifically for elevated sprocket machines:

### Measurement

Use the caliper or the Ultrasonic Wear Indicator to measure all three bushing contact sides: forward, reverse, and vertical. Use the most worn position to make projections. This practice is necessary because wear can occur in all three positions, depending on the degree of packing. The depth gauge should not be used before a bushing turn because it only measures vertical bushing wear. After a bushing turn, the depth gauge can be used to approximate wear based on the vertical dimension.

### Bushing Allowable Wear

Bushing allowable wear is based on the remaining strength to resist cracks. For low sprocket machines, the choice between two allowable wears is based on high or low impact conditions because the sprocket is close to the ground and subject to impact.

For elevated sprocket machines in most conditions, use the greater allowable wear scale. For underfoot conditions in which the bushing experiences high shock loads such as breaking rock when ripping or dozing, use the lesser wear scale. (Track jumping may cause high loads on the bushing.) The lesser wear scale may also be used for specific underfoot conditions and applications in which the bushing cracked when the greater wear scale was applied.

### Dry Joints

Link assemblies should be checked weekly for dry joints. This should be done by lightly touching the pin end or bushing after a machine has been working. A dry pin or bushing will be relatively warmer from metal-to-metal friction.

**CAUTION — the pin and bushing of a dry joint may be hot enough to burn fingers.**

Warm, squeaking and kinking joints are only indicators of potential dry joints. The only positive means of determining whether a dry track joint has developed is when pitch extension occurs. The decision to remove the track from the machine should be based on pitch extension only. Measure the next pin away from the dry joint in both directions to be sure you have recorded the pitch extension correctly. The single joint pitch extension should not exceed the wear limits shown in the following chart.

## Components

### Pins and Bushings (Cont'd.)

#### Dry Joint Wear Limit

Model	New Track Pitch	Single Joint Wear Limit
D4H D5M, D5N 561M, 561N	6.75 in. (171.5 mm)	7.25 in. (184.2 mm)
D5H D6M, D6N 517	7.50 in. (190 mm)	8.00 in. (203.2 mm)
D6H, D6R, D6T 527	8.00 in. (203.2 mm)	8.50 in. (215.9 mm)
D7H, D7R	8.50 in. (215.9 mm)	9.00 in. (228.6 mm)
D8L, D8N, D8R 572R 578 583R	8.50 in. (215.9 mm)	8.75 in. (223.3 mm)
D8T	8.58 in (218 mm)	8.83 in (224.3 mm)
D9L, 589	9.00 in. (228.6 mm)	9.25 in. (235 mm)
D9N, D9R, D9T	9.45 in. (240 mm)	9.70 in. (246.4 mm)
D10 D10N, D10R, D10T	10.25 in. (260.4 mm)	10.50 in. (266.7 mm)
D11N, D11R, D11T	12.50 in. (317.5 mm)	12.75 in. (323.9 mm)

#### Shoe & Master Link Bolt Torque/Turn Specifications

Model	Bolt Size	Torque <sup>(1)</sup>	Additional Turn	
			Regular Shoe	Master Link Master Shoe
D4H D5H, D5M, D5N 561M, 561N	5/8 in.	125 ± 30 ft. lb. 170 ± 40 Nm	+ 1/3 turn	+ 1/2 turn
D5H D6M, D6N D6H, D6R, D6T D7H 572R 517 527	3/4 in.	300 ± 50 ft. lb. 400 ± 70 Nm	+ 1/3 turn	+ 1/3 turn
D7H, D7R	7/8 in.	250 ± 50 ft. lb. 340 ± 70 Nm	+ 1/3 turn	+ 1/2 turn
D8L, D8N, D8R, D8T, 578 583R	7/8 in.	480 ± 50 ft. lb. 650 ± 70 Nm	+ 1/3 turn	+ 1/3 turn
D9L, D9N, D9R, D9T 589	1 in.	650 ± 50 ft. lb. 870 ± 70 Nm	+ 1/3 turn	+ 1/3 turn

1 See, page 29 and, page 47 for assembling and torque tightening procedures.

**Pins and Bushings (Cont'd.)**

**Shoe & Master Link Bolt Torque/Turn Specifications (Cont'd.)**

Model	Bolt Size	Torque <sup>(1)</sup>	Additional Turn	
			Regular Shoe	Master Link Master Shoe
D10	1-1/8 in.	650 ± 70 ft. lb. 870 ± 90 Nm	+ 1/3 turn	+ 1/3 turn
D10N, D10R, D10T 5-tooth Masters	1-1/8 in.	650 ± 70 ft. lb. 870 ± 90 Nm	+ 1/3 turn	+ 1/3 turn
D10N, D10R, D10T Single Tooth Masters	1-1/8 in.	516 ± 52 ft. lb. 700 ± 70 Nm	+ 1/3 turn	+ 1/4 turn
D11N, D11R, D11T 5-tooth Masters	1-3/8 in.	1105 ± 110 ft. lb. 1500 ± 150 Nm	+ 1/3 turn	+ 1/2 turn
D11N, D11R, D11T Single Tooth Masters	1-3/8 in. M36	1105 ± 110 ft. lb. 1500 ± 150 Nm	+ 1/3 turn	+ 1/4 turn

**SystemOne Shoe and Master Link Track Torque/Turn Specifications\***

Model	Bolt Size	Standard Links Track Shoes		Clamp Master (Open Window)		Clamp Master (Center Strut)	
		Pre Torque	Additional Turn	Pre Torque	Additional Turn	Pre Torque	Additional Turn
D4H D5M, D5N	16 mm	107 ± 18 ft-lb 145 ± 25 Nm	1/3 Turn	184 ± 18 ft-lb 250 ± 25 Nm	4 x 1/4 turn <sup>(2)</sup>		
D6N, D6M	20 mm	295 ± 18 ft-lb 400 ± 25 Nm	1/3 Turn	221 ± 18 ft-lb 300 ± 25 Nm	4 x 1/4 turn <sup>(2)</sup>	295 ± 18 ft-lb 400 ± 25 Nm	1/2 turn
D6H, D6R, D6T	22 mm	369 ± 18 ft-lb 500 ± 25 Nm	1/3 Turn	295 ± 18 ft-lb 400 ± 25 Nm	4 x 1/4 turn <sup>(2)</sup>	369 ± 18 ft-lb 500 ± 25 Nm	1/2 turn
Split Master							
D8N, D8R D8T	7/8 in	480 ± 50 ft-lb 650 ± 70 Nm	1/3 Turn	480 ± 50 ft-lb 650 ± 70 Nm	1/3 Turn		

\* For detailed Installation and Removal of SystemOne Clamp Masters, see Undercarriage Reconditioning Bulletin, REHS2220.

\*\* Use the [Assembling and Tightening Procedure](#), page 29.

- 1 See, page 29 and, page 47 for assembling and torque tightening procedures.
- 2 Turn each bolt 90 degrees (1/4) at a time for four (4) turns so deflection is uniform. These turns are to be completed in a clockwise pattern.

## Components

---

---

### Shoes

---

See, [page 44 through, page 47](#) for detailed shoe information.

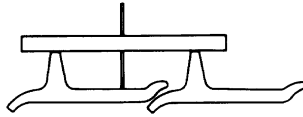

**Measurement** — Use the depth gauge or the Ultrasonic Wear Indicator to measure shoes.

**Shoe Width** — Wide track shoes are a major cause of undercarriage component failures and dry joints. See [Shoes, page 44](#) for a detailed discussion of the effects of wide track shoes.

---

### Idlers

---

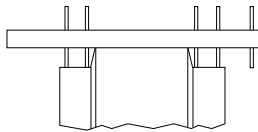

See, [page 49](#) for detailed idler information.

**Measurement** – Use the depth gauge to measure both treads of the idler. Use the same depth gauge probe positions as you use for rollers, but do not use the reference hooks. For D8 through D11 tractors, position the bar so two posts are over each tread and press the bar down. Measure the length of all four posts and use the largest measurement to determine percent worn. For D4 through D7 tractors, position the bar so that one probe is over the center of each tread. Use the average measurement to determine percent worn.

**Idler Swapping** – In some situations, wear between front to rear or left to right idlers may be uneven. If this occurs, follow the guidelines [on, page 50](#) to determine if a swap is necessary.

Due to differences in front and rear idler diameters, swapping is not possible on the D4H, D4H XL, D5M XL, D5N XL, D6H (serial number ranges 1KD402-661, 2TG1-543, 3YG1-556, 4GG1-465, 5HG1-441, 8FC1-717, 8FC461-964, 8YC473-UP), D8N, D8R, and D8T.

#### **Idler Wear – Center Tread Idlers and Relieved Center Tread Idlers**

##### **Measurement Technique**

Center Tread Idler tread wear is measured with the Ultrasonic Wear Indicator, Depth Gauge, or with the small caliper.

Relieved Center Tread Idler wear is measured with the Depth Gauge or with the small caliper. These cannot be measured with the Ultrasonic Wear Indicator.

Both Relieved Tread and Center Tread Idlers must be measured on the side of the idler with the part number.

To provide a measurement location, the side of the idler with the part number is either machined around the entire inside diameter or notched. Only the early version idlers were notched.

Relieved Tread and Center Tread Idlers must be measured on the machined or notched surface as indicated below. This is very close to the outside edge of the tread surface. Care must be exercised to not measure onto the radius.

## Idlers (Cont'd.)



For complete details on Relieved Tread idler wear and re-use guidelines, reference Special Instruction REHS7608.

### Wear Limits

Center Tread Idler allowable wear and resulting wear limits are based on the rebuildability of the idler.

If the idler is worn past 100 percent, the tread will become too thin to successfully rebuild. Note that Relieved Tread idlers are not rebuildable.

### Wear Charts

Relieved Tread and Center Tread Idlers wear at a slower rate than conventional idlers, and the wear rate will not increase as rapidly after the hardened case depth is worn away.

### Rebuildability

Rebuildability of Center Tread Idlers is comparable to conventional idlers. The Relieved Center Tread Idlers are not rebuildable.

### Installation

Note that only the part number side of the idler is machined or notched and that the part number side should be installed to face the outside of the machine.

### Idler Guard Wear Packages for D8T, D9T, D10T, D11T

Increase link, roller and idler wear life by up to 40% by installing flexible rubber idler guards. These guards are for use in moderate to high abrasive and low impact underfoot conditions. They work by preventing abrasive material from entering the undercarriage system. For details, reference IRM UC01-06 (PELM1002).

### Testing and Adjusting Front Idler Position and Machine Balance (D4H to D7R)

Operator complaints of uncomfortable ride are generally caused by an idler that is lower than the track rollers, a machine that is not balanced, or scalloped track links.

Special Instruction entitled "Adjustment of the Position of the Front Idlers and the Balance of the Machine for Improved Ride or Improved Fine Dozing," REHS0862-02, dated June 01, 2001, covers the following topics:

- Correct Track Installation
- Measuring Grouser Rise Height
- Verify the Installation of the Correct Idlers
- Measuring the Depth of the Link Scallop
- Shim Charts for Idlers
- Measuring the Height of the Front Idler Tread
- Checking the Balance of the Machine

## Components

### Idlers (Cont'd.)

- Adjusting the Height of Center Tread Idlers

#### Procedure to Determine Idler Height

(D8L, D8N, D8R, D8T, D9L, D9N, D9R, D9T, D10, D10N, D10R, D10T, D11N, D11R, D11T Tractors)

Model	Applicable Serial Numbers
D8L	All
D8N	All
D8R	All
D8T	All
D9L	All
D9N	All
D9R	All
D9T	All
D10	All
D10N	All
D10R	All
D10T	All
D11N	All
D11R	All
D11T	All

As track rollers wear and bogie pads deteriorate or are lost, excessive machine vibration may result. This vibration is the result of insufficient idler height. Idler height is the distance that the tread of the track idler is above the tread of the adjacent track roller. See Illustration 1 for the area to be measured.

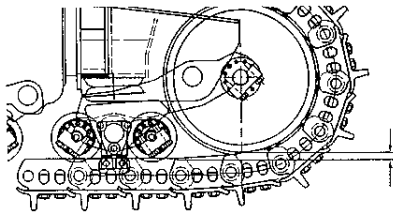

Illustration 1. Idler Height

Under typical operating conditions, wear causes the radius of the track roller treads to decrease at approximately twice the rate of the idlers. When the front or rear rollers reach approximately 70 percent worn, the idler height may approach the minimum recommended value. Variations in operating conditions influence the wear rates.

Additionally, the installation of new or rebuilt idlers on machines with partially worn track rollers directly affects idler height.



## Idlers (Cont'd.)

To measure idler height, use the following procedure.

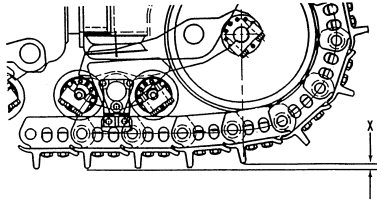

Illustration 2. Measurement points on a hard surface.

- 1** Move the machine to a hard, level surface. Inspect to make sure all bogie pads are in place. If any pads are missing or deteriorated, they should be replaced.
- 2** To check front idler height, carefully move the machine in REVERSE until a track shoe grouser is directly below the center of the idler shaft. See Illustration 2.
- 3** Measure the distance (dimension X), between the bottom of the track shoe grouser in full contact with the surface and the bottom of the track shoe grouser directly below the idler shaft.
- 4** Repeat the procedure of aligning the track shoe grouser directly below the center of the idler shaft on the rear idler by carefully moving the machine forward. Measure dimension X for the rear idler.
- 5** Idler height varies from model to model and between front and rear idlers. Compare dimension X with the recommended nominal and minimum values for the front and rear idlers that correspond to your model as shown in Chart A.

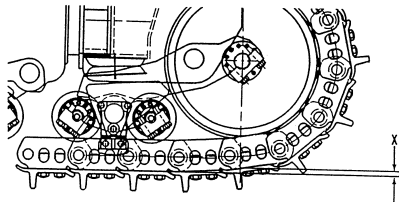

Illustration 3. Measurement points on a soft surface.

**Note:** In the event that a suitable hard surface is not available for checking idler height, a less accurate method may be used. See steps 6 and 7 below.

- 6** Carefully move the machine in REVERSE until a track shoe grouser is directly below the center of the idler shaft.
- 7** Stretch a length of string along the top edge of the track shoes. Dimension X is measured from the string to the point where the center line of the idler shaft intersects the top of the track shoe which is directly below it. See Illustration 3 for the location of dimension X.

## Components

### Idlers (Cont'd.)

**Chart A**

Model	Front Idler Nominal	Front Idler Minimum	Rear Idler Nominal	Rear Idler Minimum
D8L	29 mm (1.142 in.)	17 mm (.670 in.)	34 mm (1.339 in.)	10 mm (.394 in.)
D8N, D8R, D8T	15 mm (.591 in.)	10 mm (.394 in.)	16 mm (.630 in.)	10 mm (.394 in.)
D9L	23 mm (.906 in.)	11 mm (.433 in.)	27 mm (1.063 in.)	11 mm (.433 in.)
D9N, D9R, D9T	24 mm (.945 in.)	11 mm (.433 in.)	21 mm (.827 in.)	11 mm (.433 in.)
D10	25 mm (.984 in.)	14 mm (.551 in.)	32 mm (1.260 in.)	12 mm (.472 in.)
D10N, D10R, D10T	26 mm (1.024 in.)	14 mm (.551 in.)	23 mm (.906 in.)	12 mm (.472 in.)
D11N, D11R, D11T	32 mm (1.260 in.)	14 mm (.551 in.)	23 mm (.906 in.)	12 mm (.472 in.)

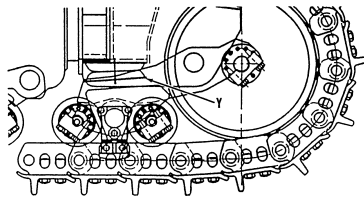

Illustration 4. Add plates at point Y.

**Chart B**

Model	Plate Part No.	Plate Thickness
D8N, D8R, D8T	7T-4699	5 mm (.196 in.)
D9N, D9R, D9T	321-7862	5 mm (.196 in.)
D9L, D10N, D10R, D10T	9P-2704	5 mm (.196 in.)
D10, D11N, D11R, D11T	8P-8884	5 mm (.196 in.)

**⚠ WARNING**

**Prior to adding plates under the bogie pads, raise the machine until the bogies are hanging free. Carefully support the machine. See the disassembly and assembly module in your machine's Service Manual for the correct procedure.**

- If dimension X is less than the minimum shown in Chart A, plates should be added between the lower bogie pad and the top of the major bogie assemblies at point Y. The appropriate plates and their part number are listed in Chart B. See Illustration 4 for the correct location to add plates.

The addition of one plate installed under a front or rear bogie pad increases idler height by approximately 7.50 mm (.295 in.). In order to maintain uniform roller loading, equal number of plates must be installed under the intermediate bogie pads. Take care not to install more plates than are necessary to achieve the proper idler height dimension. Excessive idler height results in poor dozer control, particularly while performing finish dozing operations.

## Track Rollers

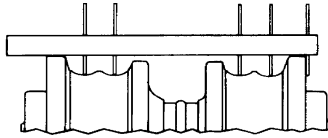

See, [page 56 through, page 59](#) for detailed track roller information. The following points are specifically for elevated sprocket tractors.

**Measurement** — For D8 through 11 tractors, measurement of track rollers must be done using the depth gauge or the Ultrasonic Wear Indicator. Calipers are not feasible due to close roller spacing. The depth gauge, calipers or the Ultrasonic Wear Indicator may be used on D4 through D7 tractors.

For D8 through D11 track rollers, set the farthest probe on the measurement tool as a reference hook. Set the probes in the appropriate holes for the model being measured. Position the bar across the roller so the reference hook is against the outside of the outer flange and the probes are resting on the grooves of the roller. These rollers develop wear grooves as explained [on, page 56](#). Push the bar down flush with the flanges. Then measure the exposed length of all four probes and use the average measurement to determine percent worn. For D4 through D7 tractors, position the bar so that one probe is over the center of each tread. Use the largest measurement to determine percent worn.

**Wear Charts** — For undercarriage systems where links and track rollers are wearing at the same rate, you should continue to use the 100% to 120% destruction guidelines. This is due to link pin boss contact with external roller flanges or, for large machines, bushing contact with internal roller flanges.

On elevated sprocket machines, track roller wear charts extend past 120% worn to allow you to better estimate 'destruction' point. For these machines, roller wear charts extend to the point where tread wear meets the retainer bolts. For track rollers with end collars, and therefore no retainer bolts, wear charts extend to the same diameter as rollers with retainers. This is useful for machines where links are less worn than track rollers. Keep in mind that rollers, depending on application, may fail due to structure before they reach this point.

**Roller Swapping** — Depending on the situation, the front and/or rear rollers wear faster than the middle rollers. A swap may be necessary to extend roller life to the link service or destruction point. To determine whether a swap is necessary, follow the guidelines [on, page 59](#). The larger machines, D8 and above, have large diameter (extended wear life) single flange rollers. For these machines, keep in mind these single flange rollers can only be swapped into positions where other single flange rollers are located.

### Roller Flange Sequence

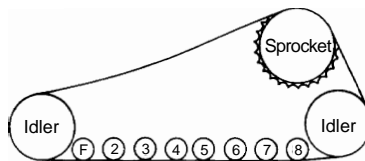

From the chart which follows, you will note that the rear roller (the roller nearest the rear idler) is a single flange roller. If a double flange roller were used as the rear roller, interference could occur between the inner flange and the rear idler. Therefore, a double flange roller should **NOT** usually be placed in the rear position.

# Components

## Track Rollers (Cont'd.)

### Roller Flange Sequence (Cont'd.)

**Wear Chart Design** — On elevated sprocket machines, track roller wear charts extend past 120% worn to allow you to better estimate 'destruction' point. For these machines, the wear charts extend to the point where tread wear meets the retainer bolts. This is to help you better estimate when the rollers might destruct if link wear is very low or if the roller flanges have been trimmed.

For machines like the D6N, where some rollers have retainers and some have end collars, the wear charts for both types of rollers continue to the same point, even though there are no retainer bolts on the end collar rollers.

For undercarriage systems where links and track rollers are wearing at the same rate, you should continue to use the 100% to 120% destruction guidelines. This is due to link pin boss contact with external roller flanges or, for large machines, bushing contact with internal roller flanges.

Model	Rollers Per Side	Roller Position							
		F	2	3	4	5	6	7	8
<b>Track-Type Tractors</b>									
D4H <sup>(3)</sup> , D4H XL <sup>(3)</sup> , D4H LGP <sup>(3)</sup>	7	S	D	S	D	S	D	S	
D5M <sup>(3)</sup> , D5M XL <sup>(3)</sup> , D5M XR <sup>(3)</sup> D5M LGP <sup>(3)</sup> , D5N <sup>(3)</sup> , D5N XL <sup>(3)</sup>									
D4H LGP <sup>(3)</sup> D5M LGP <sup>(3)</sup> D5N LGP <sup>(3)</sup>	8	S	D	S	D	D	S	D	S
D5H	6	S	D	S	S	D	S		
D5H XL, D5H TSK D6M, D6N <sup>(3)</sup>	7	S	D	S	D	S	D	S	
D5H LGP D6M LGP <sup>(3)</sup> , D6N LGP <sup>(3)</sup>	8	S	D	S	D	D	S	D	S
D6H <sup>(3)</sup> , D6R <sup>(3)</sup> , D6T <sup>(3)</sup>	6	S	D	S	D	S	S		
D6H XL <sup>(3)</sup> , D6H XR <sup>(3)</sup> D6R XL <sup>(3)</sup> , D6R XR <sup>(3)</sup> , D6R XW <sup>(3)</sup> , D6T XL <sup>(3)</sup> , D6T XW <sup>(3)</sup>	7	S	D	S	D	S	D	S	
D6H LGP <sup>(3)</sup> , D6R LGP <sup>(3)</sup> , D6T LGP <sup>(3)</sup>	8	S	D	S	D	D	S	D	S
D7H, D7H LGP, D7R, D7R LGP	7	S	D	S	D	S	D	S	

3 Machines with SystemOne track rollers have single flange track rollers in all positions.

**Track Rollers (Cont'd.)**

Model	Rollers Per Side	Roller Position							
		F	2	3	4	5	6	7	8
<b>Track-Type Tractors</b>									
D7H XR, D7R XR	8	S	D	S	D	D	S	D	S
D8L <sup>(4)</sup> , D8N <sup>(4)</sup> , D8R <sup>(4)</sup> , D8T <sup>(4)</sup>	8	S	S	D	D	D	D	S	S
D9L <sup>(4)</sup> , D9N <sup>(4)</sup> , D9R <sup>(4)</sup> , D9T <sup>(4)</sup>	8	S	S	D	D	D	D	S	S
D10 <sup>(4)</sup> , D10N <sup>(4)</sup> , D10R <sup>(4)</sup> , D10T <sup>(4)</sup>	8	S	S	D	D	D	D	S	S
D11N <sup>(4)</sup> , D11R <sup>(4)</sup> , D11T <sup>(4)</sup>	8	S	S	D	D	D	D	S	S

Model	Rollers Per Side	Roller Position									
		F	2	3	4	5	6	7	8	9	10
<b>Pipelayers</b>											
561H, 561M, 561N	7	S	D	S	D	S	D	S			
572R	7	S	D	S	D	S	D	S			
578 <sup>(4)</sup>	8	S	S	D	D	D	D	S	S		
583R <sup>(4)</sup>	7	D	D	S	S	D	D	S			
589 <sup>(4)</sup>	10	S	S	D	D	D	D	D	D	S	S

Model	Rollers Per Side	Roller Position							
		F	2	3	4	5	6	7	8
<b>Track Skidders</b>									
517, 527	7	S	D	S	D	S	D	S	
517, 527	8	S	D	S	D	D	S	D	S

4 Machines where single flange rollers are larger than double flange rollers.

## Components

---

---

### Sprockets

---

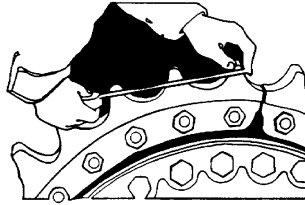

**Measurement** — To determine the sprocket segment percent worn, measure the minimum distance between a drive side on the original tooth and the opposite drive side of a sprocket tooth located three teeth away. It is important to note that the distance measured should be between teeth on the same segment. Avoid measuring between teeth on different segments as this may yield an incorrect measurement.

**Wear Patterns** — The sprockets on these machines are elevated, reducing the effects of abrasives, packing and virtually eliminates impact. Wear patterns exhibited on these sprockets are similar, but not identical, to those seen on low sprocket machines. Segment replacement is recommended at bushing turn time to reduce back-side bushing wear rate.

During early hour operation of elevated sprocket tractors, contact (scrubbing) between the track link and the side of the sprocket segment can occur. Experience has shown that this scrubbing is common and usually subsides after about 200 hours of operation. Extensive investigation indicates that the stack up of tolerances in the components of the roller frame and the final drive result in the tendency for the track to favor one side or the other of the sprocket.

Sprocket scrubbing has been observed on many machines operating in a variety of applications. Custom Track Services (CTS) data showed no detrimental effect on the wear life of the undercarriage caused by sprocket scrubbing. A similar type of contact (scrubbing) may also be observed on the track guides.

**Sprocket Bolt Torques** — Use the torque-turn tightening method [on, page 63](#).

**Sprockets (Cont'd.)**

**Sprocket Bolt Torque Specifications**

Model	Bolt Size	Torque	Additional Turn
D4H	5/8 in.	130 ± 30 ft. lb.	+ 1/3 turn
D5M, D5N		175 ± 40 Nm	
D5H			
D6M, D6N			
D6R, D6T			
561M, 561N			
527			
D7H, D7R	3/4 in.	220 ± 40 ft. lb.	+ 1/3 turn
D8L, D8N, D8R, D8T		300 ± 50 Nm	
572R			
578			
583R			
D9	7/8 in.	650 ± 50 ft. lb.	+ 1/3 turn
589		870 ± 70 Nm	
D9N, D9R, D9T	7/8 in.	480 ± 50 ft. lb.	+ 1/3 turn
		650 ± 70 Nm	
D10, D10N,	1 in.	650 ± 50 ft. lb.	+ 1/3 turn
D10R, D10T,		870 ± 70 Nm	
D11N, D11R, D11T			
D11N, D11R, D11T	1 1/8 in.	650 ± 50 ft. lb.	+ 1/3 turn
		870 ± 70 Nm	

**Guides**

**Inspection** — D8 through D11 machines do not use front and rear guiding or roller (rock) guards because of the oscillating suspension system. Instead, “L” -shaped “guides” are used to aid track guiding. These guides attach in pairs to major bogies with two bolts. No measurable service limits have been developed for guides. They should be inspected for wear and hardware retention. D4 through D7 machines use conventional front and rear guiding guards. Wear strips should be inspected regularly and replaced as required.

# Track Adjustments

## Track Adjustment

Incorrectly adjusted track can cost you money both in accelerated undercarriage wear and downtime. If the track is too tight, damaging non-productive loads are placed on the undercarriage and its manual components.

Tight track accelerates track wear and reduces tractor drawbar horsepower. Adjustment procedures take only a few minutes and require only one person.

When adjusting your track on any Caterpillar machine:

1. Always adjust the track in the working area
2. Do not try to squeeze any packing material from in between the track.
3. Never loosen the relief valve more than one turn. Grease and oil are under extreme pressure and can penetrate the body, causing serious injury.

## Elevated Sprocket Tractors



**Grease is under high pressure.**

**Grease coming out of the relief valve under pressure can penetrate the body causing injury or death.**

**Do not watch the relief valve to see if grease is escaping. Watch the track or track adjustment cylinder to see if the track is being loosened.**

- 1 Move the tractor forward and let it coast to a stop without applying the brakes. Make sure slack is between the sprocket and front idler. Then park the machine and turn off the engine.

Place a tight line over the grouser tips from the sprocket to the front idler.

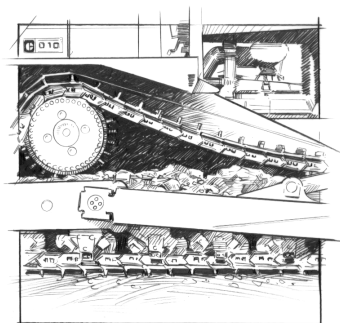

- 2 For machines without carrier rollers, measure the distance "A" from the line to the grouser tip at the lowest point of sag. Refer to Chart 1 to determine the correct sag for each model.

For machines with carrier rollers, measure the distance from the line to the grouser tips in two places: at the lowest point of sag "A" between the front idler and carrier roller and between the carrier roller and sprocket. Then average the two measurements.

Refer to Chart 2 to determine the correct sag for each model.



## Elevated Sprocket Tractors (Cont'd.)

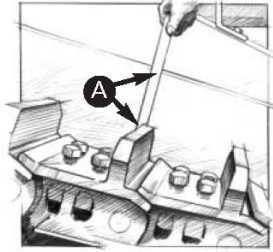

- 3** If your track requires adjustment, locate the hydraulic fill and relief valve in the rear roller frame, and remove the inspection cover.

Using a manual grease gun, add grease at the adjustment mechanism to tighten the track. To loosen the track, open the relief valve and allow grease to escape. Then close the relief valve.

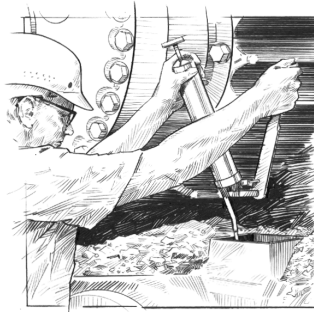

- 4** Operate the machine in forward and reverse, then re-measure track tension.

To avoid damage to internal roller frame components, do not allow the length of the exposed tube "B" to exceed the dimensions listed in Chart 3.

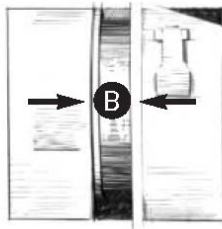

## Track Adjustments

**Chart 1**  
**Proper Track Sag**  
**Machines Without Carrier Rollers**

Model	Minimum	Target	Maximum
D4H, D5H 561H, 561M, 561N	3.5 in. (90 mm)	3.9 in. (100 mm)	4.3 in. (110 mm)
D4H Custom Skidder, D4H TSK, 517, D5H Custom Skidder, D5H TSK	2.6 in. (65 mm)	3.0 in. (75 mm)	3.4 in. (85 mm)
D6H, D6R, D6T	4.1 in. (105 mm)	4.5 in. (115 mm)	4.9 in. (125 mm)
527	2.6 in. (65 mm)	3.0 in. (75 mm)	3.4 in. (85 mm)
D7H, D7R	4.6 in. (117 mm)	5.0 in. (127 mm)	5.4 in. (137 mm)
D8L	5.1 in. (130 mm)	5.5 in. (140 mm)	5.9 in. (150 mm)
D8N, D8R, D8T, 572R, 578	4.1 in. (105 mm)	4.5 in. (115 mm)	4.9 in. (125 mm)
583R, 583T, 587R, 587T	3.5 in. (90 mm)	3.9 in. (100 mm)	4.3 in. (110 mm)
D8N, D8R, D8T SystemOne	4.1 in. (105 mm)	4.5 in. (115 mm)	4.9 in. (125 mm)
If sprocket jump	3.5 in. (90 mm)	3.9 in. (100 mm)	4.3 in. (110 mm)
If severe sprocket jump	3.2 in. (80 mm)	3.5 in. (90 mm)	3.9 in. (100 mm)
D9N, D9R, D9T	4.7 in. (120 mm)	5.1 in. (130 mm)	5.5 in. (140 mm)
D9L, 589, D10, D10N, D10R, D10T	5.7 in. (145 mm)	6.1 in. (155 mm)	6.5 in. (165 mm)
D11N, D11R, D11T	6.1 in. (155 mm)	6.5 in. (165 mm)	6.9 in. (175 mm)

**Chart 2**  
**Proper Track Sag**  
**Machines With Carrier Rollers**

Model	Minimum	Target	Maximum
D4H, D5M, D5N, 561H, 561M, 561N	1.0 in. (25 mm)	1.4 in. (35 mm)	1.8 in. (45 mm)
D5H, D6M, D6N	1.8 in. (45 mm)	2.2 in. (55 mm)	2.6 in. (65 mm)
D5H, D6M, D6N SystemOne	1.6 in. (40 mm)	1.8 in. (45 mm)	2.0 in. (50 mm)
D6H, D6R, D6T	1.8 in. (45 mm)	2.2 in. (55 mm)	2.6 in. (65 mm)
D6H, D6R, D6T SystemOne	1.6 in. (40 mm)	1.8 in. (45 mm)	2.0 in. (50 mm)
D7H, D7R, 572R	2.2 in. (55 mm)	2.6 in. (65 mm)	3.0 in. (75 mm)
D8L, D8N, D8R, D8T, 578	2.2 in. (55 mm)	2.6 in. (65 mm)	3.0 in. (75 mm)
583R, 583T, 587R, 587T	2.0 in. (50 mm)	2.4 in. (60 mm)	2.8 in. (70 mm)
D8N, D8R, D8T SystemOne	2.2 in. (55 mm)	2.6 in. (65 mm)	3.0 in. (75 mm)
If sprocket jump	2.0 in. (50 mm)	2.4 in. (60 mm)	2.8 in. (70 mm)
If severe sprocket jump	1.8 in. (45 mm)	2.2 in. (55 mm)	2.6 in. (65 mm)
D9N, D9R, D9T	2.2 in. (55 mm)	2.6 in. (65 mm)	3.0 in. (75 mm)

## Track Adjustments

Model	Minimum	Target	Maximum
D9L, 589, D10, D10N, D10R, D10T	2.4 in. (60 mm)	2.8 in. (70 mm)	3.2 in. (80 mm)
D11N, D11R, D11T	2.6 in. (65 mm)	3.0 in. (75 mm)	3.4 in. (85 mm)

**Chart 3**  
**Track Roller Frame Extension Specifications**

Model	Serial Numbers	Maximum Length of Exposed Tube	
		Inches	Millimeters
D4H		3.9	(100)
D5M LGP, D5N LGP		3.5	(88.5)
D5M XL, D5N XL		3.6	(91.7)
561H, 561M, 561N		3.9	(100)
D5H		4.4	(112)
D6M XL, D6N XL		4.0	(102.4)
D6M LGP, D6N LGP		4.3	(108.2)
517		4.4	(112)
D6H XL		6.0	(153.5)
D6H LGP		6.2	(156.8)
D6H, D6H XR		6.4	(161.8)
D6R XW	(AEP) (Series II) (Series III)	5.7	(144.2)
D6R XL	(4MN00504 & UP) (5LN02766 & UP) (Series II) (Series III)	5.7	(144.2)
D6R XL	(4MN00001-4MN00503) (5LN00001-5LN02765)	6.0	(153.5)
D6R LGP	(8LN0529 & UP) (9PN1579 & UP) (ACJ) (ADE) (Series II) (Series III)	5.6	(142.5)
D6R LGP	(8LN0001-8LN0528) (9PN0001-9PN1578)	6.0	(151.8)
D6R XR	(6JN00416 & UP) (7KN00451 & UP)	5.8	(147.5)
D6R XR	(6JN00001-00415) (7KN00001-7KN00450)	6.2	(156.8)
D6R	(2YN00545 & UP) (AFM) (AEM) (9ZS) (3ZN00763 & UP) (2HM) (6FR) (1RW) (4FM) (5PR) (Series II) (Series III)	5.8	(147.5)
D6R	(2YN0001-2YN00544) (3ZN00001-3ZN00762)	6.2	(156.8)
D6T XL, D6T XW		5.7	(144.2)
D6T LGP		5.6	(142.5)

## Track Adjustments

Model	Serial Numbers	Maximum Length of Exposed Tube	
		Inches	Millimeters
D6T		5.8	(147.5)
527		6.2	(156.8)
D7H, D7H XR, D7H LGP		5.0	(127)
D7R XR, D7R LGP, D7R XR II, D7R LGP II		5.4	(136.5)
D7R		5.4	(136)
572R		5.0	(127)
572R II		5.6	(142)
D8L		6.5	(165)
D8N		5.6	(142)
D8R	(9EM) (AKA) (7XM05094 & UP) (6YZ)	6.0	(152)
D8R	(7XM00001-7XM05093)	5.6	(142)
D8T		6.0	(152)
578		5.6	(142)
583R, 583T		6.0	(152)
587R, 587T		6.0	(152)
589	(31Z)	6.0	(152)
D9L		6.3	(160)
589	(8HB)	6.3	(160)
D9N		5.9	(150)
D9R	(8BL01422-UP) (7TL01212-UP)	7.4	(189)
D9R	(8BL00001-8BL01421) (7TL00001-7TL01211)	5.9	(150)
D9R	(JJB) (ACL) (ABK) (WDM)	7.4	(189)
D9T	(RJS)	7.4	(189)
D10	(84W) (76X)	5.8	(148)
D10L	(2YD00001 - DYD00515)	5.8	(148)
D10N	(2YD00516-UP) (3SK)	6.8	(173)
D10R		7.6	(194)
D10T		7.6	(194)
D11N		7.0	(178)
D11R		7.8	(198)
D11T		7.8	(198)

# D4H, D5M, D5N - 6.75 IN. (171.5 mm)

## Track Links <sup>(1)</sup> SystemOne Track 235-2514

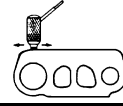
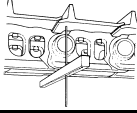

Depth Gauge			Ultrasonic	
Inches	(mm)	% Worn	Inches	(mm)
4.25	(108.0)	0	1.14	(29.0)
4.23	(107.5)	6	1.12	(28.4)
4.21	(107.0)	12	1.10	(27.9)
4.19	(106.5)	18	1.08	(27.4)
4.17	(106.0)	24	1.06	(26.9)
4.15	(105.5)	30	1.04	(26.4)
4.13	(105.0)	35	1.02	(25.9)
4.11	(104.5)	40	1.00	(25.4)
4.09	(104.0)	45	0.98	(24.9)
4.07	(103.5)	50	0.96	(24.4)
4.05	(103.0)	55	0.94	(23.9)
4.03	(102.5)	60	0.92	(23.4)
4.01	(102.0)	65	0.90	(22.9)
3.99	(101.5)	70	0.88	(22.4)
3.97	(101.0)	75	0.86	(21.8)
3.95	(100.5)	80	0.84	(21.3)
3.93	(100.0)	85	0.82	(20.8)
3.91	(99.5)	90	0.80	(20.3)
3.89	(99.0)	95	0.78	(19.8)
3.87	(98.5)	100	0.76	(19.3)
3.85	(98.0)	105	0.74	(18.8)
3.83	(97.5)	110	0.72	(18.3)
3.81	(97.0)	115	0.70	(17.8)
3.79	(96.5)	120	0.68	(17.3)

# D4H, D5M, D5N, 561H, 561M, 561N - 6.75 in (171.5 mm)

## Track Links <sup>(1)</sup> Heavy Duty Track Rotating Bushing Track 108-0947 & 48

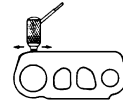
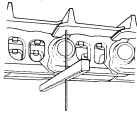

Depth Gauge			Ultrasonic	
Inches	(mm)	% Worn	Inches	(mm)
4.17	(106.0)	0	1.22	(31.0)
4.15	(105.5)	6	1.20	(30.5)
4.13	(105.0)	12	1.18	(30.0)
4.11	(104.5)	18	1.16	(29.5)
4.09	(104.0)	24	1.14	(29.0)
4.07	(103.5)	30	1.12	(28.4)
4.05	(103.0)	36	1.10	(27.9)
4.03	(102.5)	42	1.08	(27.4)
4.01	(102.0)	48	1.06	(26.9)
3.99	(101.5)	54	1.04	(26.4)
3.97	(101.0)	60	1.02	(25.9)
3.95	(100.5)	65	1.00	(25.4)
3.93	(100.0)	70	1.98	(24.9)
3.91	(99.5)	75	0.96	(24.4)
3.89	(99.0)	80	0.94	(23.9)
3.87	(98.5)	85	0.92	(23.4)
3.85	(98.0)	90	0.90	(22.9)
3.83	(97.5)	95	0.88	(22.4)
3.81	(97.0)	100	0.86	(21.8)
3.79	(96.5)	105	0.84	(21.3)
3.77	(96.0)	110	0.82	(20.8)
3.75	(95.5)	115	0.80	(20.3)
3.73	(94.5)	120	0.78	(19.8)

1 Wear Chart: 50

# D4H, D5M, D5N, 561H, 561M, 561N — 6.75 in. (171.5 mm)

**Track Links <sup>(1)</sup>**  
**6Y-9261 & 62**  
**9G-8581 & 82**

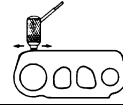
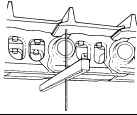

Depth Gauge			Ultrasonic	
Inches	(mm)	% Worn	Inches	(mm)
3.85	(98.0)	0	1.06	(26.9)
3.83	(97.5)	8	1.04	(26.4)
3.81	(97.0)	16	1.02	(25.9)
3.79	(96.5)	23	1.00	(25.4)
3.77	(96.0)	30	0.98	(24.9)
3.75	(95.5)	37	0.96	(24.4)
3.73	(94.5)	44	0.94	(23.9)
3.71	(94.0)	51	0.92	(23.4)
3.69	(93.5)	58	0.90	(22.9)
3.67	(93.0)	65	0.88	(22.4)
3.65	(92.5)	72	0.86	(21.8)
3.63	(92.0)	79	0.84	(21.3)
3.61	(91.5)	86	0.82	(20.8)
3.59	(91.0)	93	0.80	(20.3)
3.57	(90.5)	100	0.78	(19.8)
3.55	(90.0)	107	0.76	(19.3)
3.53	(89.5)	114	0.74	(18.8)
3.51	(89.0)	121	0.72	(18.3)

# D4H, D5M, D5N - 6.75 in. (171.5 mm)

## Bushings <sup>(1)</sup> SystemOne Track

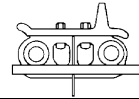
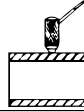

Caliper			Ultrasonic		Depth Gauge	
Inches	(mm)	% Worn	Inches	(mm)	Inches	(mm)
2.39	(60.7)	0	0.43	(10.9)	3.04	(77.2)
2.37	(60.2)	6	0.42	(10.7)	3.03	(77.0)
2.35	(59.7)	12	0.41	(10.4)	3.02	(76.7)
2.33	(59.2)	18	0.40	(10.2)	3.01	(76.5)
2.31	(58.7)	24	0.39	(9.9)	3.00	(76.2)
2.29	(58.2)	30	0.38	(9.7)	2.99	(75.9)
2.27	(57.7)	36	0.37	(9.4)	2.98	(75.7)
2.25	(57.2)	42	0.36	(9.1)	2.97	(75.4)
2.23	(56.6)	48	0.35	(8.9)	2.96	(75.2)
2.21	(56.1)	54	0.34	(8.6)	2.95	(74.9)
2.19	(55.6)	60	0.33	(8.4)	2.94	(74.7)
2.17	(55.1)	66	0.32	(8.1)	2.93	(74.4)
2.15	(54.6)	70	0.31	(7.9)	2.92	(74.2)
2.13	(54.1)	73	0.30	(7.6)	2.91	(73.9)
2.11	(53.6)	76	0.29	(7.4)	2.90	(73.7)
2.09	(53.1)	79	0.28	(7.1)	2.89	(73.4)
2.07	(52.6)	82	0.27	(6.9)	2.88	(73.2)
2.05	(52.1)	85	0.26	(6.6)	2.87	(72.9)
2.03	(51.6)	88	0.25	(6.4)	2.86	(72.6)
2.01	(51.1)	91	0.24	(6.1)	2.85	(72.4)
1.99	(50.5)	94	0.23	(5.8)	2.84	(72.1)
1.97	(50.0)	97	0.22	(5.6)	2.83	(71.9)
1.95	(49.5)	100	0.21	(5.3)	2.82	(71.6)
1.93	(49.0)	103	0.20	(5.1)	2.81	(71.4)
1.91	(48.5)	106	0.19	(4.8)	2.80	(71.1)
1.89	(48.0)	109	0.18	(4.6)	2.79	(70.9)
1.87	(47.5)	112	0.17	(4.3)	2.78	(70.6)
1.85	(47.0)	115	0.16	(4.1)	2.77	(70.4)
1.83	(46.5)	118	0.15	(3.8)	2.76	(70.1)
1.81	(46.0)	121	0.14	(3.6)	2.75	(69.9)

1 Wear Chart: 647/648



# D4H, D5M, D5N, 561H, 561M, 561N - 6.75 in. (171.5 mm)

## Bushings <sup>(1)</sup> Heavy Duty Track

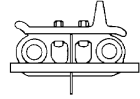
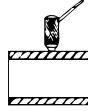
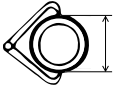

Caliper		Allowable Wear		Ultrasonic		Depth Gauge	
		Lesser % Worn	Greater % Worn	Inches	(mm)	Inches	(mm)
Inches	(mm)						
2.39	(60.7)	0	0	0.46	(11.7)	2.96	(75.2)
2.37	(60.2)	12	10	0.44	(11.2)	2.94	(74.7)
2.35	(59.7)	24	20	0.42	(10.7)	2.92	(74.2)
2.33	(59.2)	36	30	0.40	(10.2)	2.90	(73.7)
2.31	(58.7)	48	40	0.38	(9.7)	2.88	(73.2)
2.29	(58.2)	58	50	0.36	(9.1)	2.86	(72.6)
2.27	(57.7)	64	56	0.34	(8.6)	2.84	(72.1)
2.25	(57.2)	70	60	0.32	(8.1)	2.82	(71.6)
2.23	(56.6)	76	64	0.30	(7.6)	2.80	(71.1)
2.21	(56.1)	82	68	0.28	(7.1)	2.78	(70.6)
2.19	(55.6)	88	72	0.26	(6.6)	2.76	(70.1)
2.17	(55.1)	94	76	0.24	(6.1)	2.74	(69.6)
2.15	(54.6)	100	80	0.22	(5.6)	2.72	(69.1)
2.13	(54.1)	106	84	0.20	(5.1)	2.70	(68.6)
2.11	(53.6)	112	88	0.18	(4.6)	2.68	(68.1)
2.09	(53.1)	118	92	0.16	(4.1)	2.66	(67.6)
2.07	(52.6)	124	96	0.14	(3.6)	2.64	(67.1)
2.05	(52.1)		100	0.12	(3.0)	2.62	(66.5)
2.03	(51.6)		104	0.10	(2.5)	2.60	(66.0)
2.01	(51.1)		108	0.08	(2.0)	2.58	(65.5)
1.99	(50.5)		112	0.06	(1.5)	2.56	(65.0)
1.97	(50.0)		116	0.04	(1.0)	2.54	(64.5)
1.95	(49.5)		120	0.02	(0.5)	2.52	(64.0)

**Note: Do Not Use Depth Gauge Until Bushings Have Been "Turned."**

# D4H, D5M, D5N, 561H, 561M, 561N — 6.75 in. (171.5 mm)

## Bushings <sup>(1)</sup> Rotating Bushing Track

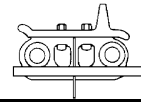
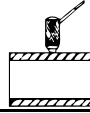
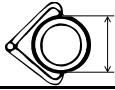

Caliper		% Worn	Ultrasonic		Depth Gauge	
Inches	(mm)		Inches	(mm)	Inches	(mm)
2.39	(60.7)	0	0.47	(11.9)	2.96	(75.2)
2.35	(59.7)	8	0.45	(11.4)	2.94	(74.7)
2.31	(58.7)	16	0.43	(10.9)	2.92	(74.2)
2.27	(57.7)	24	0.41	(10.4)	2.90	(73.7)
2.23	(56.6)	32	0.39	(9.9)	2.88	(73.2)
2.19	(55.6)	40	0.37	(9.4)	2.86	(72.6)
2.15	(54.6)	48	0.35	(8.9)	2.84	(72.1)
2.11	(53.6)	56	0.33	(8.4)	2.82	(71.6)
2.07	(52.6)	60	0.31	(7.9)	2.80	(71.1)
2.03	(51.6)	64	0.29	(7.4)	2.78	(70.6)
1.99	(50.5)	68	0.27	(6.9)	2.76	(70.1)
1.95	(49.5)	72	0.25	(6.3)	2.74	(69.6)
1.91	(48.5)	76	0.23	(5.8)	2.72	(69.1)
1.87	(47.5)	80	0.21	(5.3)	2.70	(68.6)
1.83	(46.5)	84	0.19	(4.8)	2.68	(68.1)
1.79	(45.5)	88	0.17	(4.3)	2.66	(67.6)
1.75	(44.5)	92	0.15	(3.8)	2.64	(67.1)
1.71	(43.4)	96	0.13	(3.3)	2.62	(66.5)
1.67	(42.4)	100	0.11	(2.8)	2.60	(66.0)
1.63	(41.4)	104	0.09	(2.3)	2.58	(65.5)
1.59	(40.4)	108	0.07	(1.8)	2.56	(65.0)
1.55	(39.4)	112	0.05	(1.3)	2.54	(64.5)
1.51	(38.4)	116	0.03	(0.8)	2.52	(64.0)
1.47	(37.3)	120	0.01	(0.3)	2.50	(63.5)

1 Wear Chart: 644/645

# D4H, D5M, D5N, 561H, 561M, 561N — 6.75 in. (171.5 mm)

## Bushings <sup>(1)</sup> Sealed & Lubricated Track Large Stepped Bushing

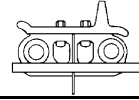
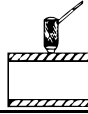
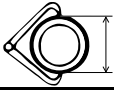

Caliper		Allowable Wear		Ultrasonic		Depth Gauge	
		Lesser % Worn	Greater % Worn				
Inches	(mm)			Inches	(mm)	Inches	(mm)
2.39	(60.7)	0	0	0.51	(13.0)	2.88	(73.2)
2.37	(60.2)	10	8	0.49	(12.4)	2.86	(72.6)
2.35	(59.7)	20	16	0.47	(11.9)	2.84	(72.1)
2.33	(59.2)	30	24	0.45	(11.4)	2.82	(71.6)
2.31	(58.7)	40	32	0.43	(10.9)	2.80	(71.1)
2.29	(58.2)	50	40	0.41	(10.4)	2.78	(70.6)
2.27	(57.7)	60	44	0.39	(9.9)	2.76	(70.1)
2.25	(57.2)	68	48	0.37	(9.4)	2.74	(69.6)
2.23	(56.6)	72	52	0.35	(8.9)	2.72	(69.1)
2.21	(56.1)	76	56	0.33	(8.4)	2.70	(68.6)
2.19	(55.6)	80	60	0.31	(7.9)	2.68	(68.1)
2.17	(55.1)	84	64	0.29	(7.4)	2.66	(67.6)
2.15	(54.6)	88	68	0.27	(6.9)	2.64	(67.1)
2.13	(54.1)	92	72	0.25	(6.3)	2.62	(66.5)
2.12	(53.6)	96	76	0.23	(5.8)	2.60	(66.0)
2.09	(53.1)	100	80	0.21	(5.3)	2.58	(65.5)
2.07	(52.6)	104	84	0.19	(4.8)	2.56	(65.0)
2.05	(52.1)	108	88	0.17	(4.3)	2.54	(64.5)
2.03	(51.6)	112	92	0.15	(3.8)	2.52	(64.0)
2.01	(51.1)	116	96	0.13	(3.3)	2.50	(63.5)
1.99	(50.5)	120	100	0.11	(2.8)	2.48	(63.0)
1.97	(50.0)		104	0.09	(2.3)	2.46	(62.5)
1.95	(49.5)		108	0.07	(1.8)	2.44	(62.0)
1.93	(49.0)		112	0.05	(1.3)	2.42	(61.5)
1.91	(48.5)		116	0.03	(0.8)	2.40	(61.0)
1.89	(48.0)		120	0.01	(0.3)	2.38	(60.5)

**Note: Do Not Use Depth Gauge Until Bushings Have Been "Turned."**

# D4H, D5M, D5N, 561H, 561M, 561N — 6.75 in. (171.5 mm)

## Bushings <sup>(1)</sup> Sealed & Lubricated Track Small Stepped Bushing

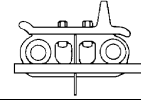

Caliper		Allowable Wear		Ultrasonic		Depth Gauge	
Inches	(mm)	Lesser % Worn	Greater % Worn	Inches	(mm)	Inches	(mm)
2.23	(56.6)	0	0	0.43	(10.9)	2.80	(71.1)
2.21	(56.1)	12	10	0.41	(10.4)	2.78	(70.6)
2.19	(55.6)	24	20	0.39	(9.9)	2.76	(70.1)
2.17	(55.1)	36	30	0.37	(9.4)	2.74	(69.6)
2.15	(54.6)	48	40	0.35	(8.9)	2.72	(69.1)
2.13	(54.1)	60	50	0.33	(8.4)	2.70	(68.6)
2.11	(53.6)	70	60	0.31	(7.9)	2.68	(68.1)
2.09	(53.1)	76	64	0.29	(7.4)	2.66	(67.6)
2.07	(52.6)	82	68	0.27	(6.9)	2.64	(67.1)
2.05	(52.1)	88	72	0.25	(6.4)	2.62	(66.5)
2.03	(51.6)	94	76	0.23	(5.8)	2.60	(66.0)
2.01	(51.1)	100	80	0.21	(5.3)	2.58	(65.5)
1.99	(50.5)	106	84	0.19	(4.8)	2.56	(65.0)
1.97	(50.0)	112	88	0.17	(4.3)	2.54	(64.5)
1.95	(49.5)	118	92	0.15	(3.8)	2.52	(64.0)
1.93	(49.0)	124	96	0.13	(3.3)	2.50	(63.5)
1.91	(48.5)		100	0.11	(2.8)	2.48	(63.0)
1.89	(48.0)		104	0.09	(2.3)	2.46	(62.5)
1.87	(47.5)		108	0.07	(1.8)	2.44	(62.0)
1.85	(47.0)		112	0.05	(1.3)	2.42	(61.5)
1.83	(46.5)		116	0.03	(0.8)	2.40	(61.0)
1.81	(46.0)		120	0.01	(0.3)	2.38	(60.5)

**Note: Do Not Use Depth Gauge Until Bushings Have Been "Turned."**

1 Wear Chart: 642

# D4H, D5M, D5N, 561H, 561M, 561N — 6.75 in. (171.5 mm)

## Track Shoes <sup>(1)</sup> Extreme Service

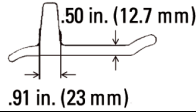
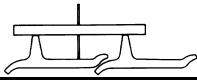

### Depth Gauge

### Ultrasonic

Inches	(mm)	% Worn	Inches	(mm)
2.25	(57.0)	0	2.75	(69.9)
2.20	(56.0)	4	2.70	(68.6)
2.15	(54.5)	8	2.65	(67.4)
2.10	(53.5)	12	2.60	(66.1)
2.05	(52.0)	16	2.55	(64.8)
2.00	(51.0)	20	2.50	(63.6)
1.95	(49.5)	24	2.45	(62.3)
1.90	(48.5)	28	2.40	(61.0)
1.85	(47.0)	32	2.35	(59.7)
1.80	(45.5)	36	2.30	(58.5)
1.75	(44.5)	40	2.25	(57.2)
1.70	(43.0)	44	2.20	(55.9)
1.65	(42.0)	48	2.15	(54.7)
1.60	(40.5)	52	2.10	(53.4)
1.55	(39.5)	56	2.05	(52.1)
1.50	(38.0)	60	2.00	(50.9)
1.45	(37.0)	64	1.95	(49.6)
1.40	(35.5)	67	1.90	(48.3)
1.35	(34.5)	70	1.85	(47.0)
1.30	(33.0)	73	1.80	(45.8)
1.25	(32.0)	76	1.75	(44.5)
1.20	(30.5)	79	1.70	(43.2)
1.15	(29.0)	82	1.65	(42.0)
1.10	(28.0)	85	1.60	(40.7)
1.05	(26.5)	88	1.55	(39.4)
1.00	(25.5)	91	1.50	(38.2)
0.95	(24.0)	94	1.45	(36.9)
0.90	(23.0)	97	1.40	(35.6)
0.85	(21.5)	100	1.35	(34.3)
0.80	(20.5)	103	1.30	(33.1)
0.75	(19.0)	106	1.25	(31.8)
0.70	(18.0)	109	1.20	(30.5)
0.65	(16.5)	112	1.15	(29.3)
0.60	(15.0)	115	1.10	(28.0)
0.55	(14.0)	118	1.05	(26.7)
0.50	(12.5)	121	1.00	(25.5)

# D4H, D5M, D5N, 561H, 561M, 561N — 6.75 in. (171.5 mm)

## Track Shoes <sup>(1)</sup> Moderate Service

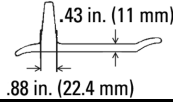
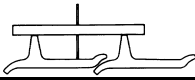

### Depth Gauge

### Ultrasonic

Inches	(mm)	% Worn	Inches	(mm)
1.85	(47.0)	0	2.30	(58.4)
1.80	(45.5)	5	2.25	(57.2)
1.75	(44.5)	10	2.20	(55.9)
1.70	(43.0)	15	2.15	(54.6)
1.65	(42.0)	20	2.10	(53.3)
1.60	(40.5)	25	2.05	(52.1)
1.55	(39.5)	30	2.00	(50.8)
1.50	(38.0)	35	1.95	(49.5)
1.45	(37.0)	40	1.90	(48.3)
1.40	(35.5)	45	1.85	(47.0)
1.35	(34.5)	50	1.80	(45.7)
1.30	(33.0)	55	1.75	(44.5)
1.25	(32.0)	60	1.70	(43.2)
1.20	(30.5)	64	1.65	(41.9)
1.15	(29.0)	68	1.60	(40.6)
1.10	(28.0)	72	1.55	(39.4)
1.05	(26.5)	76	1.50	(38.1)
1.00	(25.5)	80	1.45	(36.8)
0.95	(24.0)	84	1.40	(35.6)
0.90	(23.0)	88	1.35	(34.3)
0.85	(21.5)	92	1.30	(33.0)
0.80	(20.5)	96	1.25	(31.8)
0.75	(19.0)	100	1.20	(30.5)
0.70	(18.0)	104	1.15	(29.2)
0.65	(16.5)	108	1.10	(27.9)
0.60	(15.0)	112	1.05	(26.7)
0.55	(14.0)	116	1.00	(25.4)
0.50	(12.5)	120	0.95	(24.1)

# D4H, D5M, D5N, 561H, 561M, 561N — 6.75 in. (171.5 mm)

Track Shoes <sup>(1)</sup>  
Self Cleaning



Depth Gauge

Inches	(mm)	% Worn
3.18	(81.0)	0
3.16	(80.5)	6
3.14	(80.0)	12
3.12	(79.0)	18
3.10	(78.5)	24
3.08	(78.0)	30
3.06	(77.5)	36
3.04	(77.0)	42
3.02	(76.5)	48
3.00	(76.0)	54
2.98	(75.5)	60
2.96	(75.0)	66
2.94	(74.5)	72
2.92	(74.0)	76
2.90	(73.5)	80
2.88	(73.0)	84
2.86	(72.5)	88
2.84	(72.0)	92
2.82	(71.5)	96
2.80	(71.0)	100
2.78	(70.5)	104
2.76	(70.0)	108
2.74	(69.5)	112
2.72	(69.0)	116
2.70	(68.5)	120

## D4H, D5M, D5N - 6.75 in. (171.5 mm)

### Idlers <sup>(1)</sup> <sup>(2)</sup> <sup>(3)</sup> Center Tread Idler

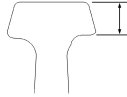

#### Ultrasonic, Depth Gauge or Caliper

Inches	(mm)	% Worn
1.10	(28.0)	0
1.08	(27.5)	5
1.06	(27.0)	10
1.04	(26.5)	15
1.02	(26.0)	20
1.00	(25.5)	25
0.98	(25.0)	30
0.96	(24.5)	34
0.94	(24.0)	37
0.92	(23.5)	40
0.90	(23.0)	43
0.88	(22.5)	46
0.86	(22.0)	49
0.84	(21.5)	52
0.82	(21.0)	55
0.80	(20.5)	58
0.78	(20.0)	61
0.76	(19.5)	64
0.74	(19.0)	67
0.72	(18.5)	70
0.70	(18.0)	73
0.68	(17.5)	76
0.66	(17.0)	79
0.64	(16.5)	82
0.62	(15.5)	85
0.60	(15.0)	88
0.58	(14.5)	91
0.56	(14.0)	94
0.54	(13.5)	97
0.52	(13.0)	100
0.50	(12.5)	103
0.48	(12.0)	106
0.46	(11.5)	109
0.44	(11.0)	112
0.42	(10.5)	115
0.40	(10.0)	118
0.38	(9.5)	121

1 New tread diameter is 21.42 in. (544 mm)

2 For measuring instructions, reference General Information topic *Idler Wear – Center Tread Idlers* on, page 51.

3 Wear Chart: 4041



## D4H, D5M, D5N, 561H, 561M, 561N - 6.75 in. (171.5 mm)

Idlers (1) (2) (3) (4)

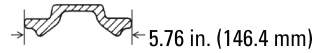
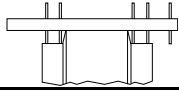

**Depth Gauge**

Inches	(mm)	% Worn
0.78	(20.0)	0
0.80	(20.5)	5
0.82	(21.0)	10
0.84	(21.5)	15
0.86	(22.0)	20
0.88	(22.5)	25
0.90	(23.0)	30
0.92	(23.5)	35
0.94	(24.0)	40
0.96	(24.5)	45
0.98	(25.0)	50
1.00	(25.5)	55
1.02	(26.0)	60
1.04	(26.5)	65
1.06	(27.0)	70
1.08	(27.5)	72
1.10	(28.0)	74
1.12	(28.5)	76
1.14	(29.0)	78
1.16	(29.5)	80
1.18	(30.0)	82
1.20	(30.5)	84
1.22	(31.0)	86
1.24	(31.5)	88
1.26	(32.0)	90
1.28	(32.5)	92
1.30	(33.0)	94
1.32	(33.5)	96
1.34	(34.0)	98
1.36	(34.5)	100
1.38	(35.0)	102
1.40	(35.5)	104
1.42	(36.0)	106
1.44	(36.5)	108
1.46	(37.0)	110
1.48	(37.5)	112
1.50	(38.0)	114
1.52	(38.5)	116
1.54	(39.0)	118
1.56	(39.5)	120

- 1 Flange width is 2.68 in. (68 mm)
- 2 New tread diameter, large idler, is 19.69 in. (500 mm)
- 3 New tread diameter, small idler, is 18.70 in. (475 mm)
- 4 Wear Chart: 4349

# D4H, D5M, D5N - 6.75 in. (171.5 mm)

## Carrier Rollers <sup>(1)</sup> SystemOne Track

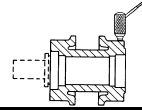
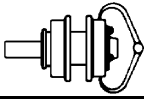

### Caliper

### Ultrasonic One-piece rim

All		% Worn	Ultrasonic One-piece rim	
Inches	(mm)		Inches	(mm)
6.64	(168.5)	0	1.28	(32.5)
6.58	(167.0)	5	1.25	(31.8)
6.52	(165.5)	10	1.22	(31.0)
6.46	(164.0)	15	1.19	(30.2)
6.40	(162.5)	20	1.16	(29.5)
6.34	(161.0)	25	1.13	(28.7)
6.28	(159.5)	30	1.10	(27.9)
6.22	(158.0)	35	1.07	(27.2)
6.16	(156.5)	40	1.04	(26.4)
6.10	(155.0)	45	1.01	(25.7)
6.04	(153.5)	50	0.98	(24.9)
5.98	(152.0)	55	0.95	(24.1)
5.92	(150.5)	60	0.92	(23.4)
5.86	(149.0)	65	0.89	(22.6)
5.80	(147.5)	70	0.86	(21.8)
5.74	(146.0)	75	0.83	(21.1)
5.68	(144.5)	79	0.80	(20.3)
5.62	(142.5)	82	0.77	(19.6)
5.56	(141.0)	85	0.74	(18.8)
5.50	(139.5)	88	0.71	(18.0)
5.44	(138.0)	91	0.68	(17.3)
5.38	(136.5)	94	0.65	(16.5)
5.32	(135.0)	97	0.62	(15.7)
5.26	(133.5)	100	0.59	(15.0)
5.20	(132.0)	103	0.56	(14.2)
5.14	(130.5)	106	0.53	(13.5)
5.08	(129.0)	109	0.50	(12.7)
5.02	(127.5)	112	0.47	(11.9)
4.96	(126.0)	115	0.44	(11.2)
4.90	(124.5)	118	0.41	(10.4)
4.84	(123.0)	121	0.38	(9.7)

1 Wear Chart: 4640

# D4H, D5M, D5N, 561H, 561M, 561N - 6.75 in (171.5 mm)

**Carrier Rollers <sup>(1)</sup>**  
**Use with 108-0947 & 48 Heavy Duty and Rotating Bushing Track**

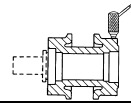
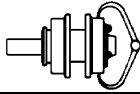

Caliper			Ultrasonic		
Inches	(mm)	% Worn	Inches	(mm)	
6.26	(159.0)	0	1.63	(41.4)	
6.20	(157.5)	5	1.60	(40.6)	
6.14	(156.0)	10	1.57	(39.9)	
6.08	(154.5)	15	1.54	(39.1)	
6.02	(153.0)	20	1.51	(38.4)	
5.96	(151.5)	25	1.48	(37.6)	
5.90	(150.0)	30	1.45	(36.8)	
5.84	(148.5)	35	1.42	(36.1)	
5.78	(147.0)	40	1.39	(35.3)	
5.72	(145.5)	45	1.36	(34.5)	
5.66	(144.0)	50	1.33	(33.8)	
5.60	(142.0)	55	1.30	(33.0)	
5.54	(140.5)	60	1.27	(32.3)	
5.48	(139.0)	65	1.24	(31.5)	
5.42	(137.5)	70	1.21	(30.7)	
5.36	(136.0)	75	1.18	(30.0)	
5.30	(134.5)	79	1.15	(29.2)	
5.24	(133.0)	82	1.12	(28.4)	
5.18	(131.5)	85	1.09	(27.7)	
5.12	(130.0)	88	1.06	(26.9)	
5.06	(128.5)	91	1.03	(26.2)	
5.00	(127.0)	94	1.00	(25.4)	
4.94	(125.5)	97	0.97	(24.6)	
4.88	(124.0)	100	0.94	(23.9)	
4.82	(122.5)	103	0.91	(23.1)	
4.76	(121.0)	106	0.88	(22.4)	
4.70	(119.5)	109	0.85	(21.6)	
4.64	(118.0)	112	0.82	(20.8)	
4.58	(116.5)	115	0.79	(20.1)	
4.52	(115.0)	118	0.76	(19.3)	
4.46	(113.5)	121	0.73	(18.5)	

# D4H, D5M, D5N, 561H, 561M, 561N — 6.75 in. (171.5 mm)

## Carrier Rollers <sup>(1)</sup> Use with 6Y Sealed and Lubricated Track

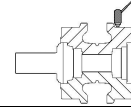
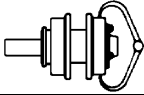

Caliper			Ultrasonic	
Inches	(mm)	% Worn	Inches	(mm)
6.26	(159.0)	0	1.63	(41.4)
6.20	(157.5)	7	1.60	(40.6)
6.14	(156.0)	14	1.57	(39.9)
6.08	(154.5)	21	1.54	(39.1)
6.02	(153.0)	28	1.51	(38.4)
5.96	(151.5)	35	1.48	(37.6)
5.90	(150.0)	42	1.45	(36.8)
5.84	(148.5)	49	1.42	(36.1)
5.78	(147.0)	56	1.39	(35.3)
5.72	(145.5)	63	1.36	(34.5)
5.66	(144.0)	70	1.33	(33.8)
5.60	(142.0)	77	1.30	(33.0)
5.54	(140.5)	84	1.27	(32.3)
5.48	(139.0)	88	1.24	(31.5)
5.42	(137.5)	92	1.21	(30.7)
5.36	(136.0)	96	1.18	(30.0)
5.30	(134.5)	100	1.15	(29.2)
5.24	(133.0)	104	1.12	(28.4)
5.18	(131.5)	108	1.09	(27.7)
5.12	(130.0)	112	1.06	(26.9)
5.06	(128.5)	116	1.03	(26.2)
5.00	(127.0)	120	1.00	(25.4)

1 Wear Chart: 4647

# D4H, D5M, D5N - 6.75 in. (171.5 mm)

## Track Rollers <sup>(1) (2)</sup> SystemOne Track

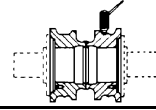
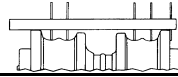
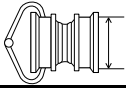

Caliper		% Worn	Depth Gauge		Ultrasonic	
Inches	(mm)		Inches	(mm)	Inches	(mm)
6.91	(175.5)	0	0.67	(17.0)	1.50	(38.1)
6.87	(174.5)	4	0.69	(17.5)	1.48	(37.6)
6.83	(173.5)	8	0.71	(18.0)	1.46	(37.1)
6.79	(172.5)	12	0.73	(18.5)	1.44	(36.6)
6.75	(171.5)	16	0.75	(19.0)	1.42	(36.1)
6.71	(170.5)	20	0.77	(19.5)	1.40	(35.6)
6.67	(169.5)	24	0.79	(20.0)	1.38	(35.1)
6.63	(168.5)	28	0.81	(20.5)	1.36	(34.5)
6.59	(167.5)	32	0.83	(21.0)	1.34	(34.0)
6.55	(166.5)	36	0.85	(21.5)	1.32	(33.5)
6.51	(165.5)	40	0.87	(22.0)	1.30	(33.0)
6.47	(164.5)	43	0.89	(22.5)	1.28	(32.5)
6.43	(163.5)	46	0.91	(23.0)	1.26	(32.0)
6.39	(162.5)	49	0.93	(23.5)	1.24	(31.5)
6.35	(161.5)	52	0.95	(24.0)	1.22	(31.0)
6.31	(160.5)	55	0.97	(24.5)	1.20	(30.5)
6.27	(159.5)	58	0.99	(25.0)	1.18	(30.0)
6.23	(158.0)	61	1.01	(25.5)	1.16	(29.5)
6.19	(157.0)	64	1.03	(26.0)	1.14	(29.0)
6.15	(156.0)	67	1.05	(26.5)	1.12	(28.4)
6.11	(155.0)	70	1.07	(27.0)	1.10	(27.9)
6.07	(154.0)	73	1.09	(27.5)	1.08	(27.4)
6.03	(153.0)	76	1.11	(28.0)	1.06	(26.9)
5.99	(152.0)	79	1.13	(28.5)	1.04	(26.4)
5.95	(151.0)	82	1.15	(29.0)	1.02	(25.9)
5.91	(150.0)	85	1.17	(29.5)	1.00	(25.4)
5.87	(149.0)	88	1.19	(30.0)	0.98	(24.9)
5.83	(148.0)	91	1.21	(30.5)	0.96	(24.4)
5.79	(147.0)	94	1.23	(31.0)	0.94	(23.9)
5.75	(146.0)	97	1.25	(32.0)	0.92	(23.4)
5.71	(145.0)	100	1.27	(32.5)	0.90	(22.9)
5.67	(144.0)	103	1.29	(33.0)	0.88	(22.4)
5.63	(143.0)	106	1.31	(33.5)	0.86	(21.8)
5.59	(142.0)	109	1.33	(34.0)	0.84	(21.3)
5.55	(141.0)	112	1.35	(34.5)	0.82	(20.8)
5.51	(140.0)	115	1.37	(35.0)	0.80	(20.3)
5.47	(139.0)	118	1.39	(35.5)	0.78	(19.8)
5.43	(138.0)	121	1.41	(36.0)	0.76	(19.3)

1 Flange diameter is 8.25 in. (209.5 mm)

2 Wear Chart: 5246

# D4H, D5M, D5N, 561H, 561M, 561N - 6.75 in. (171.5 mm)

Track Rollers with End Collars <sup>(1) (2)</sup>  
 Use with Heavy Duty or Rotating Bushing Track  
 108-0947 & 48 Links

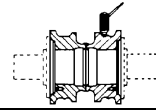
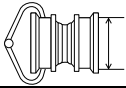

Caliper			Depth Gauge		Ultrasonic	
Inches	(mm)	% Worn	Inches	(mm)	Inches	(mm)
6.89	(175.0)	0	0.47	(12.0)	1.44	(36.6)
6.85	(174.0)	4	0.49	(12.5)	1.42	(36.1)
6.81	(173.0)	8	0.51	(13.0)	1.40	(35.6)
6.77	(172.0)	12	0.53	(13.5)	1.38	(35.1)
6.73	(171.0)	16	0.55	(14.0)	1.36	(34.5)
6.69	(170.0)	20	0.57	(14.5)	1.34	(34.0)
6.65	(169.0)	24	0.59	(15.0)	1.32	(33.5)
6.61	(168.0)	28	0.61	(15.5)	1.30	(33.0)
6.57	(167.0)	32	0.63	(16.0)	1.28	(32.5)
6.53	(166.0)	36	0.65	(16.5)	1.26	(32.0)
6.49	(165.0)	40	0.67	(17.0)	1.24	(31.5)
6.45	(164.0)	43	0.69	(17.5)	1.22	(31.0)
6.41	(163.0)	46	0.71	(18.0)	1.20	(30.5)
6.37	(162.0)	49	0.73	(18.5)	1.18	(30.0)
6.33	(161.0)	52	0.75	(19.0)	1.16	(29.5)
6.29	(160.0)	55	0.77	(19.5)	1.14	(29.0)
6.25	(159.0)	58	0.79	(20.0)	1.12	(28.4)
6.21	(157.5)	61	0.81	(20.5)	1.10	(27.9)
6.17	(156.5)	64	0.83	(21.0)	1.08	(27.4)
6.13	(155.5)	67	0.85	(21.5)	1.06	(26.9)
6.09	(154.5)	70	0.87	(22.0)	1.04	(26.4)
6.05	(153.5)	73	0.89	(22.5)	1.02	(25.9)
6.01	(152.5)	76	0.91	(23.0)	1.00	(25.4)
5.97	(151.5)	79	0.93	(23.5)	0.98	(24.9)
5.93	(150.5)	82	0.95	(24.0)	0.96	(24.4)
5.89	(149.5)	85	0.97	(24.5)	0.94	(23.9)
5.85	(148.5)	88	0.99	(25.0)	0.92	(23.4)
5.81	(147.5)	91	1.01	(25.5)	0.90	(22.9)
5.77	(146.5)	94	1.03	(26.0)	0.88	(22.4)
5.73	(145.5)	97	1.05	(26.5)	0.86	(21.8)
5.69	(144.5)	100	1.07	(27.0)	0.84	(21.3)
5.65	(143.5)	103	1.09	(27.5)	0.82	(20.8)
5.61	(142.5)	106	1.11	(28.0)	0.80	(20.3)
5.57	(141.5)	109	1.13	(28.5)	0.78	(19.8)
5.53	(140.5)	112	1.15	(29.0)	0.76	(19.3)
5.49	(139.5)	115	1.17	(29.5)	0.74	(18.8)
5.45	(138.5)	118	1.19	(30.0)	0.72	(18.3)
5.41	(137.5)	121	1.21	(30.5)	0.70	(17.8)

1 Flange diameter is 7.83 in. (199 mm)

2 Wear Chart: 5251

## D4H, D5M, D5N, 561H, 561M, 561N - 6.75 in. (171.5 mm)

**Track Rollers with End Collars <sup>(1)</sup> <sup>(2)</sup>**  
**Use with Sealed & Lubricated Track**  
**6Y-9261 & 62 Links**

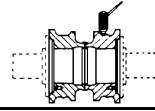
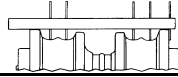
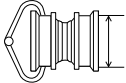

Caliper			Depth Gauge		Ultrasonic	
Inches	(mm)	% Worn	Inches	(mm)	Inches	(mm)
6.89	(175.0)	0	0.47	(12.0)	1.44	(36.6)
6.85	(174.0)	5	0.49	(12.5)	1.42	(36.1)
6.81	(173.0)	10	0.51	(13.0)	1.40	(35.6)
6.77	(172.0)	15	0.53	(13.5)	1.38	(35.1)
6.73	(171.0)	20	0.55	(14.0)	1.36	(34.5)
6.69	(170.0)	25	0.57	(14.5)	1.34	(34.0)
6.65	(169.0)	30	0.59	(15.0)	1.32	(33.5)
6.61	(168.0)	35	0.61	(15.5)	1.30	(33.0)
6.57	(167.0)	40	0.63	(16.0)	1.28	(32.5)
6.53	(166.0)	45	0.65	(16.5)	1.26	(32.0)
6.49	(165.0)	50	0.67	(17.0)	1.24	(31.5)
6.45	(164.0)	55	0.69	(17.5)	1.22	(31.0)
6.41	(163.0)	60	0.71	(18.0)	1.20	(30.5)
6.37	(162.0)	64	0.73	(18.5)	1.18	(30.0)
6.33	(161.0)	67	0.75	(19.0)	1.16	(29.5)
6.29	(160.0)	70	0.77	(19.5)	1.14	(29.0)
6.25	(159.0)	73	0.79	(20.0)	1.12	(28.4)
6.21	(157.5)	76	0.81	(20.5)	1.10	(27.9)
6.17	(156.5)	79	0.83	(21.0)	1.08	(27.4)
6.13	(155.5)	82	0.85	(21.5)	1.06	(26.9)
6.09	(154.5)	85	0.87	(22.0)	1.04	(26.4)
6.05	(153.5)	88	0.89	(22.5)	1.02	(25.9)
6.01	(152.5)	91	0.91	(23.0)	1.00	(25.4)
5.97	(151.5)	94	0.93	(23.5)	0.98	(24.9)
5.93	(150.5)	97	0.95	(24.0)	0.96	(24.4)
5.89	(149.5)	100	0.97	(24.5)	0.94	(23.9)
5.85	(148.5)	103	0.99	(25.0)	0.92	(23.4)
5.81	(147.5)	106	1.01	(25.5)	0.90	(22.9)
5.77	(146.5)	109	1.03	(26.0)	0.88	(22.4)
5.73	(145.5)	112	1.05	(26.5)	0.86	(21.8)
5.69	(144.5)	115	1.07	(27.0)	0.84	(21.3)
5.65	(143.5)	118	1.09	(27.5)	0.82	(20.8)
5.61	(142.5)	121	1.11	(28.0)	0.80	(20.3)

1 Flange diameter is 7.83 in. (199 mm)

2 Wear Chart: 5244

# D4H, D5M, D5N, 561H, 561M, 561N - 6.75 in. (171.5 mm)

**Tall Flange Track Rollers with End Collars <sup>(1)</sup> <sup>(2)</sup>**  
**Tall Flange Double Flange Rollers**  
**Use with Heavy Duty or Rotating Bushing Track**  
**108-0947 & 48 Links**

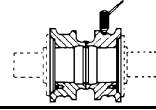
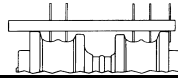
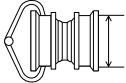

Caliper			Depth Gauge		Ultrasonic	
Inches	(mm)	% Worn	Inches	(mm)	Inches	(mm)
6.89	(175.0)	0	0.67	(17.0)	1.44	(36.6)
6.85	(174.0)	6	0.69	(17.5)	1.42	(36.1)
6.81	(173.0)	12	0.71	(18.0)	1.40	(35.6)
6.77	(172.0)	18	0.73	(18.5)	1.38	(35.1)
6.73	(171.0)	24	0.75	(19.0)	1.36	(34.5)
6.69	(170.0)	30	0.77	(19.5)	1.34	(34.0)
6.65	(169.0)	36	0.79	(20.0)	1.32	(33.5)
6.61	(168.0)	42	0.81	(20.5)	1.30	(33.0)
6.57	(167.0)	48	0.83	(21.0)	1.28	(32.5)
6.53	(166.0)	54	0.85	(21.5)	1.26	(32.0)
6.49	(165.0)	60	0.87	(22.0)	1.24	(31.5)
6.45	(164.0)	64	0.89	(22.5)	1.22	(31.0)
6.41	(163.0)	68	0.91	(23.0)	1.20	(30.5)
6.37	(162.0)	72	0.93	(23.5)	1.18	(30.0)
6.33	(161.0)	76	0.95	(24.0)	1.16	(29.5)
6.29	(160.0)	80	0.97	(24.5)	1.14	(29.0)
6.25	(159.0)	84	0.99	(25.0)	1.12	(28.4)
6.21	(157.5)	88	1.01	(25.5)	1.10	(27.9)
6.17	(156.5)	92	1.03	(26.0)	1.08	(27.4)
6.13	(155.5)	96	1.05	(26.5)	1.06	(26.9)
6.09	(154.5)	100	1.07	(27.0)	1.04	(26.4)
6.05	(153.5)	104	1.09	(27.5)	1.02	(25.9)
6.01	(152.5)	108	1.11	(28.0)	1.00	(25.4)
5.97	(151.5)	112	1.13	(28.5)	0.98	(24.9)
5.93	(150.5)	116	1.15	(29.0)	0.96	(24.4)
5.89	(149.5)	120	1.17	(29.5)	0.94	(23.9)

1 Flange diameter is 8.23 in. (209 mm)

2 Wear Chart: 6140



## D4H, D5M, D5N, 561H, 561M, 561N - 6.75 in. (171.5 mm)

**Track Rollers with Retainers <sup>(1)</sup> (2)**  
**Use with Heavy Duty or Rotating Bushing Track**  
**108-0947 & 48 Links**

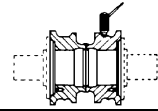
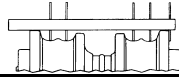

Caliper			Depth Gauge		Ultrasonic	
Inches	(mm)	% Worn	Inches	(mm)	Inches	(mm)
6.89	(175.0)	0	0.47	(12.0)	1.55	(39.4)
6.85	(174.0)	4	0.49	(12.5)	1.53	(38.9)
6.81	(173.0)	8	0.51	(13.0)	1.51	(38.4)
6.77	(172.0)	12	0.53	(13.5)	1.49	(37.8)
6.73	(171.0)	16	0.55	(14.0)	1.47	(37.3)
6.69	(170.0)	20	0.57	(14.5)	1.45	(36.8)
6.65	(169.0)	24	0.59	(15.0)	1.43	(36.3)
6.61	(168.0)	28	0.61	(15.5)	1.41	(35.8)
6.57	(167.0)	32	0.63	(16.0)	1.39	(35.3)
6.53	(166.0)	36	0.65	(16.5)	1.37	(34.8)
6.49	(165.0)	40	0.67	(17.0)	1.35	(34.3)
6.45	(164.0)	43	0.69	(17.5)	1.33	(33.8)
6.41	(163.0)	46	0.71	(18.0)	1.31	(33.3)
6.37	(162.0)	49	0.73	(18.5)	1.29	(32.8)
6.33	(161.0)	52	0.75	(19.0)	1.27	(32.3)
6.29	(160.0)	55	0.77	(19.5)	1.25	(31.8)
6.25	(159.0)	58	0.79	(20.0)	1.23	(31.2)
6.21	(157.5)	61	0.81	(20.5)	1.21	(30.7)
6.17	(156.5)	64	0.83	(21.0)	1.19	(30.2)
6.13	(155.5)	67	0.85	(21.5)	1.17	(29.7)
6.09	(154.5)	70	0.87	(22.0)	1.15	(29.2)
6.05	(153.5)	73	0.89	(22.5)	1.13	(28.7)
6.01	(152.5)	76	0.91	(23.0)	1.11	(28.2)
5.97	(151.5)	79	0.93	(23.5)	1.09	(27.7)
5.93	(150.5)	82	0.95	(24.0)	1.07	(27.2)
5.89	(149.5)	85	0.97	(24.5)	1.05	(26.7)
5.85	(148.5)	88	0.99	(25.0)	1.03	(26.2)
5.81	(147.5)	91	1.01	(25.5)	1.01	(25.7)
5.77	(146.5)	94	1.03	(26.0)	0.99	(25.1)
5.73	(145.5)	97	1.05	(26.5)	0.97	(24.6)
5.69	(144.5)	100	1.07	(27.0)	0.95	(24.1)
5.65	(143.5)	103	1.09	(27.5)	0.93	(23.6)
5.61	(142.5)	106	1.11	(28.0)	0.91	(23.1)
5.57	(141.5)	109	1.13	(28.5)	0.89	(22.6)
5.53	(140.5)	112	1.15	(29.0)	0.87	(22.1)
5.49	(139.5)	115	1.17	(29.5)	0.85	(21.6)
5.45	(138.5)	118	1.19	(30.0)	0.83	(21.1)
5.41	(137.5)	121	1.21	(30.5)	0.81	(20.6)

1 Flange diameter is 7.83 in. (199 mm)

2 Wear Chart: 5247

# D4H, D5M, D5N, 561H, 561M, 561N - 6.75 in. (171.5 mm)

Track Rollers with Retainers <sup>(1) (2)</sup>  
 Use with Sealed & Lubricated Track  
 6Y-9261 & 62 Links

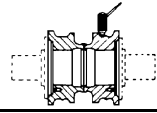
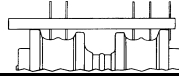
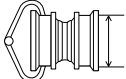

Caliper			Depth Gauge		Ultrasonic	
Inches	(mm)	% Worn	Inches	(mm)	Inches	(mm)
6.89	(175.0)	0	0.47	(12.0)	1.55	(39.4)
6.85	(174.0)	4	0.49	(12.5)	1.53	(38.9)
6.81	(173.0)	8	0.51	(13.0)	1.51	(38.4)
6.77	(172.0)	12	0.53	(13.5)	1.49	(37.8)
6.73	(171.0)	16	0.55	(14.0)	1.47	(37.3)
6.69	(170.0)	20	0.57	(14.5)	1.45	(36.8)
6.65	(169.0)	24	0.59	(15.0)	1.43	(36.3)
6.61	(168.0)	28	0.61	(15.5)	1.41	(35.8)
6.57	(167.0)	32	0.63	(16.0)	1.39	(35.3)
6.53	(166.0)	36	0.65	(16.5)	1.37	(34.8)
6.49	(165.0)	40	0.67	(17.0)	1.35	(34.3)
6.45	(164.0)	44	0.69	(17.5)	1.33	(33.8)
6.41	(163.0)	48	0.71	(18.0)	1.31	(33.3)
6.37	(162.0)	52	0.73	(18.5)	1.29	(32.8)
6.33	(161.0)	56	0.75	(19.0)	1.27	(32.3)
6.29	(160.0)	60	0.77	(19.5)	1.25	(31.8)
6.25	(159.0)	64	0.79	(20.0)	1.23	(31.2)
6.21	(157.5)	68	0.81	(20.5)	1.21	(30.7)
6.17	(156.5)	72	0.83	(21.0)	1.19	(30.2)
6.13	(155.5)	76	0.85	(21.5)	1.17	(29.7)
6.09	(154.5)	80	0.87	(22.0)	1.15	(29.2)
6.05	(153.5)	84	0.89	(22.5)	1.13	(28.7)
6.01	(152.5)	88	0.91	(23.0)	1.11	(28.2)
5.97	(151.5)	92	0.93	(23.5)	1.09	(27.7)
5.93	(150.5)	96	0.95	(24.0)	1.07	(27.2)
5.89	(149.5)	100	0.97	(24.5)	1.05	(26.7)
5.85	(148.5)	103	0.99	(25.0)	1.03	(26.2)
5.81	(147.5)	106	1.01	(25.5)	1.01	(25.7)
5.77	(146.5)	109	1.03	(26.0)	0.99	(25.1)
5.73	(145.5)	112	1.05	(26.5)	0.97	(24.6)
5.69	(144.5)	115	1.07	(27.0)	0.95	(24.1)
5.65	(143.5)	118	1.09	(27.5)	0.93	(23.6)
5.61	(142.5)	121	1.11	(28.0)	0.91	(23.1)

1 New flange diameter is 7.83 in. (199 mm)

2 Wear Chart: 5248

# D4H, D5M, D5N, 561H, 561M, 561N - 6.75 in. (171.5 mm)

**Sprockets <sup>(1)</sup>**  
**Use with:**  
**SystemOne Track**  
**Heavy Duty Track**  
**Rotating Bushing Track**  
**Sealed and Lubricated Track with Large Bushings**

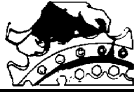

## Tape Measure

Inches	(mm)	% Worn
7.50	(190.5)	0
7.45	(189.0)	7
7.40	(188.0)	14
7.35	(186.5)	21
7.30	(185.5)	28
7.25	(184.0)	35
7.20	(183.0)	42
7.15	(181.5)	49
7.10	(180.5)	56
7.05	(179.0)	63
7.00	(178.0)	70
6.95	(176.5)	76
6.90	(175.5)	82
6.85	(174.0)	88
6.80	(172.5)	94
6.75	(171.5)	100
6.70	(171.5)	106
6.65	(169.0)	112
6.60	(167.5)	118
6.55	(166.5)	124

### NOTE

Measure across 3 teeth

# D4H, D5M, D5N, 561H, 561M, 561N - 6.75 in. (171.5 mm)

**Sprockets <sup>(1)</sup>**  
**Use with: Sealed and Lubricated Track with Small Bushings**



## Tape Measure

Inches	(mm)	% Worn
7.60	(193.0)	0
7.55	(192.0)	6
7.50	(190.5)	12
7.45	(189.0)	18
7.40	(188.0)	24
7.35	(186.5)	30
7.30	(185.5)	36
7.25	(184.0)	42
7.20	(183.0)	48
7.15	(181.5)	54
7.10	(180.5)	60
7.05	(179.0)	66
7.00	(178.0)	72
6.95	(176.5)	78
6.90	(175.5)	84
6.85	(174.0)	90
6.80	(172.5)	95
6.75	(171.5)	100
6.70	(170.0)	105
6.65	(169.0)	110
6.60	(167.5)	115
6.55	(166.5)	120

### NOTE

Measure across 3 teeth

## D5H, D6M, D6N - 7.50 in (190 mm)

### Track Links <sup>(1)</sup> SystemOne Track 235-2501

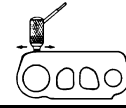
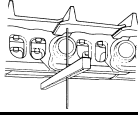

Depth Gauge			Ultrasonic	
Inches	(mm)	% Worn	Inches	(mm)
4.78	(121.5)	0	1.45	(36.8)
4.76	(121.0)	5	1.43	(36.3)
4.74	(120.5)	10	1.41	(35.8)
4.72	(120.0)	15	1.39	(35.3)
4.70	(119.5)	20	1.37	(34.8)
4.68	(119.0)	25	1.35	(34.3)
4.66	(118.5)	30	1.33	(33.8)
4.64	(118.0)	35	1.31	(33.3)
4.62	(117.5)	40	1.29	(32.8)
4.60	(117.0)	45	1.27	(32.3)
4.58	(116.5)	50	1.25	(31.8)
4.56	(116.0)	55	1.23	(31.2)
4.54	(115.5)	60	1.21	(30.7)
4.52	(115.0)	65	1.19	(30.2)
4.50	(114.5)	70	1.17	(29.7)
4.48	(114.0)	75	1.15	(29.2)
4.46	(113.5)	80	1.13	(28.7)
4.44	(113.0)	84	1.11	(28.2)
4.42	(112.5)	88	1.09	(27.7)
4.40	(112.0)	92	1.07	(27.2)
4.38	(111.5)	96	1.05	(26.7)
4.36	(110.5)	100	1.03	(26.2)
4.34	(110.0)	104	1.01	(25.7)
4.32	(109.5)	108	0.99	(25.1)
4.30	(109.0)	112	0.97	(24.6)
4.28	(108.5)	116	0.95	(24.1)
4.26	(108.0)	120	0.93	(23.6)

# D5H, D5R, D6M, D6N, 517 - 7.50 in (190 mm)

## Track Links <sup>(1)</sup> Heavy Duty Track Rotating Bushing Track 106-1625 & 26

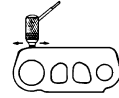
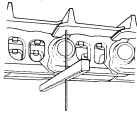

Depth Gauge			Ultrasonic	
Inches	(mm)	% Worn	Inches	(mm)
4.68	(119.0)	0	1.53	(38.9)
4.66	(118.5)	5	1.51	(38.4)
4.64	(118.0)	10	1.49	(37.8)
4.62	(117.5)	15	1.47	(37.3)
4.60	(117.0)	20	1.45	(36.8)
4.58	(116.5)	25	1.43	(36.3)
4.56	(116.0)	30	1.41	(35.8)
4.54	(115.5)	35	1.39	(35.3)
4.52	(115.0)	40	1.37	(34.8)
4.50	(114.5)	45	1.35	(34.3)
4.48	(114.0)	50	1.33	(33.8)
4.46	(113.5)	55	1.31	(33.3)
4.44	(113.0)	60	1.29	(32.8)
4.42	(112.5)	65	1.27	(32.3)
4.40	(112.0)	70	1.25	(31.8)
4.38	(111.5)	75	1.23	(31.2)
4.36	(110.5)	80	1.21	(30.7)
4.34	(110.0)	84	1.19	(30.2)
4.32	(109.5)	88	1.17	(29.7)
4.30	(109.0)	92	1.15	(29.2)
4.28	(108.5)	96	1.13	(28.7)
4.26	(108.0)	100	1.11	(28.2)
4.24	(107.5)	104	1.09	(27.7)
4.22	(107.0)	108	1.07	(27.2)
4.20	(106.5)	112	1.05	(26.7)
4.18	(106.0)	116	1.03	(26.2)
4.16	(105.5)	120	1.01	(25.7)

## D5H, D5R, D6M, D6N, 517 - 7.50 in. (190 mm)

### Track Links <sup>(1)</sup> General Duty 417-3595 & 96

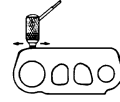
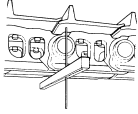

Depth Gauge			Ultrasonic	
Inches	(mm)	% Worn	Inches	(mm)
4.68	(119.0)	0	1.53	(38.9)
4.66	(118.5)	6	1.51	(38.4)
4.64	(118.0)	12	1.49	(37.8)
4.62	(117.5)	18	1.47	(37.3)
4.60	(117.0)	24	1.45	(36.8)
4.58	(116.5)	30	1.43	(36.3)
4.56	(116.0)	36	1.41	(35.8)
4.54	(115.5)	42	1.39	(35.3)
4.52	(115.0)	48	1.37	(34.8)
4.50	(114.5)	54	1.35	(34.3)
4.48	(114.0)	60	1.33	(33.8)
4.46	(113.5)	65	1.31	(33.3)
4.44	(113.0)	68	1.29	(32.8)
4.42	(112.5)	72	1.27	(32.3)
4.40	(112.0)	75	1.25	(31.8)
4.38	(111.5)	79	1.23	(31.2)
4.36	(110.5)	82	1.21	(30.7)
4.34	(110.0)	86	1.19	(30.2)
4.32	(109.5)	89	1.17	(29.7)
4.30	(109.0)	93	1.15	(29.2)
4.28	(108.5)	96	1.13	(28.7)
4.26	(108.0)	100	1.11	(28.2)
4.24	(107.5)	103	1.09	(27.7)
4.22	(107.0)	107	1.07	(27.2)
4.20	(106.5)	110	1.05	(26.7)
4.18	(106.0)	114	1.03	(26.2)
4.16	(105.5)	117	1.01	(25.7)
4.14	(105.0)	121	0.99	(25.1)

# D5H - 7.50 in. (190 mm)

## Track Links <sup>(1)</sup> Enhanced SALT Track 229-6909 & 10

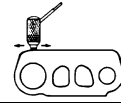
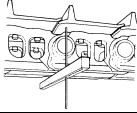

Depth Gauge			Ultrasonic	
Inches	(mm)	% Worn	Inches	(mm)
4.48	(114.0)	0	1.43	(36.3)
4.46	(113.5)	5	1.41	(35.8)
4.44	(113.0)	10	1.39	(35.3)
4.42	(112.5)	15	1.37	(34.8)
4.40	(112.0)	20	1.35	(34.3)
4.38	(111.5)	25	1.33	(33.8)
4.36	(110.5)	30	1.31	(33.3)
4.34	(110.0)	35	1.29	(32.8)
4.32	(109.5)	40	1.27	(32.3)
4.30	(109.0)	45	1.25	(31.8)
4.28	(108.5)	50	1.23	(31.2)
4.26	(108.0)	55	1.21	(30.7)
4.24	(107.5)	60	1.19	(30.2)
4.22	(107.0)	65	1.17	(29.7)
4.20	(106.5)	70	1.15	(29.2)
4.18	(106.0)	75	1.13	(28.7)
4.16	(105.5)	80	1.11	(28.2)
4.14	(105.0)	84	1.09	(27.7)
4.12	(104.5)	88	1.07	(27.2)
4.10	(104.0)	92	1.05	(26.7)
4.08	(103.5)	96	1.03	(26.2)
4.06	(103.0)	100	1.01	(25.7)
4.04	(102.5)	104	0.99	(25.1)
4.02	(102.0)	108	0.97	(24.6)
4.00	(101.5)	112	0.95	(24.1)
3.98	(101.0)	116	0.93	(23.6)
3.96	(100.5)	120	0.91	(23.1)



**Track Links <sup>(1)</sup>  
Sealed & Lubricated Track  
3T-8405 & 06  
6Y-9267 & 68**

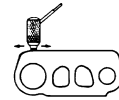
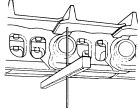

Depth Gauge			Ultrasonic	
Inches	(mm)	% Worn	Inches	(mm)
4.33	(110.0)	0	1.27	(32.3)
4.31	(109.5)	6	1.25	(31.8)
4.29	(109.0)	12	1.23	(31.2)
4.27	(108.5)	18	1.21	(30.7)
4.25	(108.0)	24	1.19	(30.2)
4.23	(107.5)	30	1.17	(29.7)
4.21	(107.0)	36	1.15	(29.2)
4.19	(106.5)	42	1.13	(28.7)
4.17	(106.0)	48	1.11	(28.2)
4.15	(105.5)	54	1.09	(27.7)
4.13	(105.0)	60	1.07	(27.2)
4.11	(104.5)	65	1.05	(26.7)
4.09	(104.0)	70	1.03	(26.2)
4.07	(103.5)	75	1.01	(25.7)
4.05	(103.0)	80	0.99	(25.1)
4.03	(102.5)	85	0.97	(24.6)
4.01	(102.0)	90	0.95	(24.1)
3.99	(101.5)	95	0.93	(23.6)
3.97	(101.0)	100	0.91	(23.1)
3.95	(100.5)	105	0.89	(22.6)
3.93	(100.0)	110	0.87	(22.1)
3.91	(99.5)	115	0.85	(21.6)
3.89	(99.0)	120	0.83	(21.1)

# D5H, D6M, D6N - 7.50 in. (190 mm)

## Bushings <sup>(1)</sup> SystemOne Track

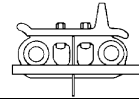
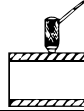

Caliper			Ultrasonic		Depth Gauge	
Inches	(mm)	% Worn	Inches	(mm)	Inches	(mm)
2.56	(65.0)	0	0.48	(12.2)	3.28	(83.3)
2.54	(64.5)	6	0.47	(11.9)	3.27	(83.1)
2.52	(64.0)	12	0.46	(11.7)	3.26	(82.8)
2.50	(63.5)	18	0.45	(11.4)	3.25	(82.6)
2.48	(63.0)	24	0.44	(11.2)	3.24	(82.3)
2.46	(62.5)	30	0.43	(10.9)	3.23	(82.0)
2.44	(62.0)	36	0.42	(10.7)	3.22	(81.8)
2.42	(61.5)	42	0.41	(10.4)	3.21	(81.5)
2.40	(61.0)	46	0.40	(10.2)	3.20	(81.3)
2.38	(60.5)	49	0.39	(9.9)	3.19	(81.0)
2.36	(59.9)	52	0.38	(9.7)	3.18	(80.8)
2.34	(59.4)	55	0.37	(9.4)	3.17	(80.5)
2.32	(58.9)	58	0.36	(9.1)	3.16	(80.3)
2.30	(58.4)	61	0.35	(8.9)	3.15	(80.0)
2.28	(57.9)	64	0.34	(8.6)	3.14	(79.8)
2.26	(57.4)	67	0.33	(8.4)	3.13	(79.5)
2.24	(56.9)	70	0.32	(8.1)	3.12	(79.2)
2.22	(56.4)	73	0.31	(7.9)	3.11	(79.0)
2.20	(55.9)	76	0.30	(7.6)	3.10	(78.7)
2.18	(55.4)	79	0.29	(7.4)	3.09	(78.5)
2.16	(54.9)	82	0.28	(7.1)	3.08	(78.2)
2.14	(54.4)	85	0.27	(6.9)	3.07	(78.0)
2.12	(53.8)	88	0.26	(6.6)	3.06	(77.7)
2.10	(53.3)	91	0.25	(6.3)	3.05	(77.5)
2.08	(52.8)	94	0.24	(6.1)	3.04	(77.2)
2.06	(52.3)	97	0.23	(5.8)	3.03	(77.0)
2.04	(51.8)	100	0.22	(5.6)	3.02	(76.7)
2.02	(51.3)	103	0.21	(5.3)	3.01	(76.5)
2.00	(50.8)	106	0.20	(5.1)	3.00	(76.2)
1.98	(50.3)	109	0.19	(4.8)	2.99	(75.9)
1.96	(49.8)	112	0.18	(4.6)	2.98	(75.7)
1.94	(49.3)	115	0.17	(4.3)	2.97	(75.4)
1.92	(48.8)	118	0.16	(4.1)	2.96	(75.2)
1.90	(48.3)	121	0.15	(3.8)	2.95	(74.9)

1 Wear Chart: 685/686

# D5H, D5R, D6M, D6N, 517 - 7.50 in. (190 mm)

## Bushings <sup>(1)</sup> Heavy Duty Track

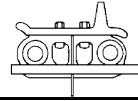
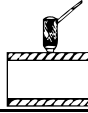
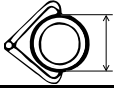

Caliper		Allowable Wear		Ultrasonic		Depth Gauge	
Inches	(mm)	Lesser % Worn	Greater % Worn	Inches	(mm)	Inches	(mm)
2.56	(65.0)	0	0	0.51	(13.0)	3.19	(81.0)
2.54	(64.5)	10	8	0.49	(12.4)	3.17	(80.5)
2.52	(64.0)	20	16	0.47	(11.9)	3.15	(80.0)
2.50	(63.5)	30	24	0.45	(11.4)	3.13	(79.5)
2.48	(63.0)	40	32	0.43	(10.9)	3.11	(79.0)
2.46	(62.5)	50	40	0.41	(10.4)	3.09	(78.5)
2.44	(62.0)	60	48	0.39	(9.9)	3.07	(78.0)
2.42	(61.5)	70	52	0.37	(9.4)	3.05	(77.5)
2.40	(61.0)	76	56	0.35	(8.9)	3.03	(77.0)
2.38	(60.5)	80	60	0.33	(8.4)	3.01	(76.5)
2.36	(59.9)	84	64	0.31	(7.9)	2.99	(75.9)
2.34	(59.4)	88	68	0.29	(7.4)	2.97	(75.4)
2.32	(58.9)	92	72	0.27	(6.9)	2.95	(74.9)
2.30	(58.4)	96	76	0.25	(6.3)	2.93	(74.4)
2.28	(57.9)	100	80	0.23	(5.8)	2.91	(73.9)
2.26	(57.4)	104	84	0.21	(5.3)	2.89	(73.4)
2.24	(56.9)	108	88	0.19	(4.8)	2.87	(72.9)
2.22	(56.4)	112	92	0.17	(4.3)	2.85	(72.4)
2.20	(55.9)	116	96	0.15	(3.8)	2.83	(71.9)
2.18	(55.4)	120	100	0.13	(3.3)	2.81	(71.4)
2.16	(54.9)		104	0.11	(2.8)	2.79	(70.9)
2.14	(54.4)		108	0.09	(2.3)	2.77	(70.4)
2.12	(53.8)		112	0.07	(1.8)	2.75	(69.9)
2.10	(53.3)		116	0.05	(1.3)	2.73	(69.3)
2.08	(52.8)		120	0.03	(0.8)	2.71	(68.8)

**Note: Do Not Use Depth Gauge Until Bushings Have Been "Turned."**

# D5H, D6M, D6N, 517 - 7.50 in. (190 mm)

## Bushings <sup>(1)</sup> Rotating Bushing Track

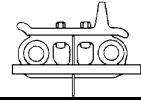
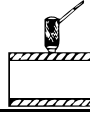
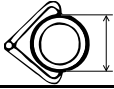

Caliper		% Worn	Ultrasonic		Depth Gauge	
Inches	(mm)		Inches	(mm)	Inches	(mm)
2.56	(65.0)	0	0.52	(13.2)	3.19	(81.0)
2.52	(64.0)	8	0.50	(12.7)	3.17	(80.5)
2.48	(63.0)	16	0.48	(12.2)	3.15	(80.0)
2.44	(62.0)	24	0.46	(11.7)	3.13	(79.5)
2.40	(61.0)	32	0.44	(11.2)	3.11	(79.0)
2.36	(59.9)	40	0.42	(10.7)	3.09	(78.5)
2.32	(58.9)	44	0.40	(10.2)	3.07	(78.0)
2.28	(57.9)	48	0.38	(9.7)	3.05	(77.5)
2.24	(56.9)	52	0.36	(9.1)	3.03	(77.0)
2.20	(55.9)	56	0.34	(8.6)	3.01	(76.5)
2.16	(54.9)	60	0.32	(8.1)	2.99	(75.9)
2.12	(53.8)	64	0.30	(7.6)	2.97	(75.4)
2.08	(52.8)	68	0.28	(7.1)	2.95	(74.9)
2.04	(51.8)	72	0.26	(6.6)	2.93	(74.4)
2.00	(50.8)	76	0.24	(6.1)	2.91	(73.9)
1.96	(49.8)	80	0.22	(5.6)	2.89	(73.4)
1.92	(48.8)	84	0.20	(5.1)	2.87	(72.9)
1.88	(47.8)	88	0.18	(4.6)	2.85	(72.4)
1.84	(46.7)	92	0.16	(4.1)	2.83	(71.9)
1.80	(45.7)	96	0.14	(3.6)	2.81	(71.4)
1.76	(44.7)	100	0.12	(3.0)	2.79	(70.9)
1.72	(43.7)	104	0.10	(2.5)	2.77	(70.4)
1.68	(42.7)	108	0.08	(2.0)	2.75	(69.9)
1.64	(41.7)	112	0.06	(1.5)	2.73	(69.3)
1.60	(40.6)	116	0.04	(1.0)	2.71	(68.8)
1.56	(39.6)	120	0.02	(0.5)	2.69	(68.3)

# D5H, D5R, D6M, D6N, 517 - 7.50 in. (190 mm)

## Bushings <sup>(1)</sup> General Duty

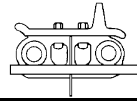
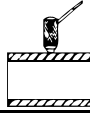

Caliper			Ultrasonic		Depth Gauge	
Inches	(mm)	% Worn	Inches	(mm)	Inches	(mm)
2.56	(65.0)	0	0.51	(13.0)	3.19	(81.0)
2.54	(64.5)	10	0.49	(12.4)	3.17	(80.5)
2.52	(64.0)	20	0.47	(11.9)	3.15	(80.0)
2.50	(63.5)	30	0.45	(11.4)	3.13	(79.5)
2.48	(63.0)	40	0.43	(10.9)	3.11	(79.0)
2.46	(62.5)	50	0.41	(10.4)	3.09	(78.5)
2.44	(62.0)	60	0.39	(9.9)	3.07	(78.0)
2.42	(61.5)	64	0.37	(9.4)	3.05	(77.5)
2.40	(61.0)	67	0.35	(8.9)	3.03	(77.0)
2.38	(60.5)	70	0.33	(8.4)	3.01	(76.5)
2.36	(59.9)	73	0.31	(7.9)	2.99	(75.9)
2.34	(59.4)	76	0.29	(7.4)	2.97	(75.4)
2.32	(58.9)	79	0.27	(6.9)	2.95	(74.9)
2.30	(58.4)	82	0.25	(6.3)	2.93	(74.4)
2.28	(57.9)	85	0.23	(5.8)	2.91	(73.9)
2.26	(57.4)	88	0.21	(5.3)	2.89	(73.4)
2.24	(56.9)	91	0.19	(4.8)	2.87	(72.9)
2.22	(56.4)	94	0.17	(4.3)	2.85	(72.4)
2.20	(55.9)	97	0.15	(3.8)	2.83	(71.9)
2.18	(55.4)	100	0.13	(3.3)	2.81	(71.4)
2.16	(54.9)	103	0.11	(2.8)	2.79	(70.9)
2.14	(54.4)	106	0.09	(2.3)	2.77	(70.4)
2.12	(53.8)	109	0.07	(1.8)	2.75	(69.9)
2.10	(53.3)	112	0.05	(1.3)	2.73	(69.3)
2.08	(52.8)	115	0.03	(0.8)	2.71	(68.8)
2.06	(52.3)	118	0.01	(0.3)	2.69	(68.3)

# D5H, D6M, D6N, 517 - 7.50 in. (190 mm)

## Bushings <sup>(1)</sup> Sealed and Lubricated Track Enhanced SALT Track

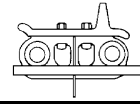
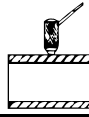

Caliper		Allowable Wear		Ultrasonic		Depth Gauge	
Inches	(mm)	Lesser % Worn	Greater % Worn	Inches	(mm)	Inches	(mm)
2.53	(64.3)	0	0	0.52	(13.2)	3.11	(79.0)
2.51	(63.8)	10	8	0.50	(12.7)	3.09	(78.5)
2.49	(63.2)	20	16	0.48	(12.2)	3.07	(78.0)
2.47	(62.7)	30	24	0.46	(11.7)	3.05	(77.5)
2.45	(62.2)	40	32	0.44	(11.2)	3.03	(77.0)
2.43	(61.7)	50	40	0.42	(10.7)	3.01	(76.5)
2.41	(61.2)	60	44	0.40	(10.2)	2.99	(75.9)
2.39	(60.7)	68	48	0.38	(9.7)	2.97	(75.4)
2.37	(60.2)	72	52	0.36	(9.1)	2.95	(74.9)
2.35	(59.7)	76	56	0.34	(8.6)	2.93	(74.4)
2.33	(59.2)	80	60	0.32	(8.1)	2.91	(73.9)
2.31	(58.7)	84	64	0.30	(7.6)	2.89	(73.4)
2.29	(58.2)	88	68	0.28	(7.1)	2.87	(72.9)
2.27	(57.7)	92	72	0.26	(6.6)	2.85	(72.4)
2.25	(57.2)	96	76	0.24	(6.1)	2.83	(71.9)
2.23	(56.6)	100	80	0.22	(5.6)	2.81	(71.4)
2.21	(56.1)	104	84	0.20	(5.1)	2.79	(70.9)
2.19	(55.6)	108	88	0.18	(4.6)	2.77	(70.4)
2.17	(55.1)	112	92	0.16	(4.1)	2.75	(69.9)
2.15	(54.6)	116	96	0.14	(3.6)	2.73	(69.3)
2.13	(54.1)	120	100	0.12	(3.0)	2.71	(68.8)
2.11	(53.6)		104	0.10	(2.5)	2.69	(68.3)
2.09	(53.1)		108	0.08	(2.0)	2.67	(67.8)
2.07	(52.6)		112	0.06	(1.5)	2.65	(67.3)
2.05	(52.1)		116	0.04	(1.0)	2.63	(66.8)
2.03	(51.6)		120	0.02	(0.5)	2.61	(66.3)

**Note: Do Not Use Depth Gauge Until Bushings Have Been "Turned."**

# D5H, D5R, D6M, D6N, 517 - 7.50 in. (190 mm)

## Track Shoes <sup>(1)</sup> Extreme Service

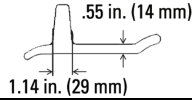
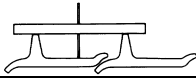

### Depth Gauge

### Ultrasonic

Inches	(mm)	% Worn	Inches	(mm)
2.55	65.0	0	3.15	80.0
2.45	62.0	6	3.05	77.5
2.35	59.5	12	2.95	74.9
2.25	57.0	18	2.85	72.4
2.15	54.5	24	2.75	69.9
2.05	52.0	30	2.65	67.3
1.95	49.5	36	2.55	64.8
1.85	47.0	42	2.45	62.2
1.75	44.5	48	2.35	59.7
1.65	42.0	54	2.25	57.2
1.55	39.5	60	2.15	54.6
1.45	37.0	66	2.05	52.1
1.35	34.5	72	1.95	49.5
1.25	32.0	78	1.85	47.0
1.15	29.0	84	1.75	44.5
1.05	26.5	90	1.65	41.9
0.95	24.0	95	1.55	39.4
0.85	21.5	100	1.45	36.8
0.75	19.0	105	1.35	34.3
0.65	16.5	110	1.25	31.8
0.55	14.0	115	1.15	29.2
0.45	11.5	120	1.05	26.7

# D5H, D5R, D6M, D6N, 517 - 7.50 in. (190 mm)

## Track Shoes <sup>(1)</sup> Moderate Service Genuine & General Duty

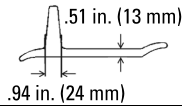
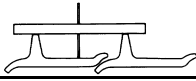

### Depth Gauge

### Ultrasonic

Inches	(mm)	% Worn	Inches	(mm)
2.25	(57.0)	0	2.75	(69.9)
2.20	(56.0)	4	2.70	(68.6)
2.15	(54.5)	8	2.65	(67.3)
2.10	(53.5)	12	2.60	(66.0)
2.05	(52.0)	16	2.55	(64.8)
2.00	(51.0)	20	2.50	(63.5)
1.95	(49.5)	24	2.45	(62.2)
1.90	(48.5)	28	2.40	(61.0)
1.85	(47.0)	31	2.35	(59.7)
1.80	(45.5)	34	2.30	(58.4)
1.75	(44.5)	37	2.25	(57.2)
1.70	(43.0)	40	2.20	(55.9)
1.65	(42.0)	43	2.15	(54.6)
1.60	(40.5)	46	2.10	(53.3)
1.55	(39.5)	49	2.05	(52.1)
1.50	(38.0)	52	2.00	(50.8)
1.45	(37.0)	55	1.95	(49.5)
1.40	(35.5)	58	1.90	(48.3)
1.35	(34.5)	61	1.85	(47.0)
1.30	(33.0)	64	1.80	(45.7)
1.25	(32.0)	67	1.75	(44.5)
1.20	(30.5)	70	1.70	(43.2)
1.15	(29.0)	73	1.65	(41.9)
1.10	(28.0)	76	1.60	(40.6)
1.05	(26.5)	79	1.55	(39.4)
1.00	(25.5)	82	1.50	(38.1)
0.95	(24.0)	85	1.45	(36.8)
0.90	(23.0)	88	1.40	(35.6)
0.85	(21.5)	91	1.35	(34.3)
0.80	(20.5)	94	1.30	(33.0)
0.75	(19.0)	97	1.25	(31.8)
0.70	(18.0)	100	1.20	(30.5)
0.65	(16.5)	103	1.15	(29.2)
0.60	(15.0)	106	1.10	(27.9)
0.55	(14.0)	109	1.05	(26.7)
0.50	(12.5)	112	1.00	(25.4)
0.45	(11.5)	115	0.95	(24.1)
0.40	(10.0)	118	0.90	(22.9)
0.35	(9.0)	121	0.85	(21.6)



# D5H, D5R, D6M, D6N, 517 - 7.50 in. (190 mm)

Track Shoes <sup>(1)</sup>  
Self Cleaning

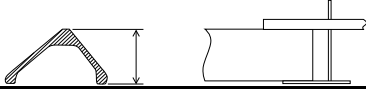

Depth Gauge

Inches	(mm)	% Worn
3.14	(80.0)	0
3.12	(79.0)	4
3.10	(78.5)	8
3.08	(78.0)	12
3.06	(77.5)	16
3.04	(77.0)	20
3.02	(76.5)	24
3.00	(76.0)	28
2.98	(75.5)	32
2.96	(75.0)	36
2.94	(74.5)	40
2.92	(74.0)	44
2.90	(73.5)	48
2.88	(73.0)	52
2.86	(72.5)	55
2.84	(72.0)	58
2.82	(71.5)	61
2.80	(71.0)	64
2.78	(70.5)	67
2.76	(70.0)	70
2.74	(69.5)	73
2.72	(69.0)	76
2.70	(68.5)	79
2.68	(68.0)	82
2.66	(67.5)	85
2.64	(67.0)	88
2.62	(66.5)	91
2.60	(66.0)	94
2.58	(65.5)	97
2.56	(65.0)	100
2.54	(64.5)	103
2.52	(64.0)	106
2.50	(63.5)	109
2.48	(63.0)	112
2.46	(62.5)	115
2.44	(62.0)	118
2.42	(61.5)	121

# D5H, D6M, D6N - 7.50 in. (190 mm)

## Idlers <sup>(1)</sup> <sup>(2)</sup> <sup>(3)</sup>

Relieved Tread Idler

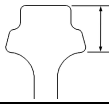

Center Tread Idler

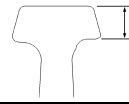

Depth Gauge, Ultrasonic (CTI only) or Caliper				
Inches	(mm)	% Worn	Inches	(mm)
1.96	(50.0)	0	1.10	(28.0)
1.94	(49.5)	4	1.08	(27.5)
1.92	(49.0)	8	1.06	(27.0)
1.90	(48.5)	12	1.04	(26.5)
1.88	(48.0)	16	1.02	(26.0)
1.86	(47.0)	20	1.00	(25.5)
1.84	(46.5)	24	0.98	(25.0)
1.82	(46.0)	28	0.96	(24.5)
1.80	(45.5)	32	0.94	(24.0)
1.78	(45.0)	36	0.92	(23.5)
1.76	(44.5)	40	0.90	(23.0)
1.74	(44.0)	44	0.88	(22.5)
1.72	(43.5)	48	0.86	(22.0)
1.70	(43.0)	52	0.84	(21.5)
1.68	(42.5)	55	0.82	(21.0)
1.66	(42.0)	58	0.80	(20.5)
1.64	(41.5)	61	0.78	(20.0)
1.62	(41.0)	64	0.76	(19.5)
1.60	(40.5)	67	0.74	(19.0)
1.58	(40.0)	70	0.72	(18.5)
1.56	(39.5)	73	0.70	(18.0)
1.54	(39.0)	76	0.68	(17.5)
1.52	(38.5)	79	0.66	(17.0)
1.50	(38.0)	82	0.64	(16.5)
1.48	(37.5)	85	0.62	(15.5)
1.46	(37.0)	88	0.60	(15.0)
1.44	(36.5)	91	0.58	(14.5)
1.42	(36.0)	94	0.56	(14.0)
1.40	(35.5)	97	0.54	(13.5)
1.38	(35.0)	100	0.52	(13.0)
1.36	(34.5)	103	0.50	(12.5)
1.34	(34.0)	106	0.48	(12.0)
1.32	(33.5)	109	0.46	(11.5)
1.30	(33.0)	112	0.44	(11.0)
1.28	(32.5)	115	0.42	(10.5)
1.26	(32.0)	118	0.40	(10.0)
1.24	(31.5)	121	0.38	(9.5)

- 1 New tread diameter: RTI is 23.50 in. (597 mm); CTI is 24.45 in. (621 mm)
- 2 For measuring instructions, reference General Information topic *Idler Wear – Center Tread Idlers and Relieved Center Tread Idlers* on, [page 51](#).
- 3 Wear Chart: 4080

# D5H, D5R, D6M, D6N, 517 - 7.50 in. (190 mm)

## Idlers (1) (2) (3) Extended Life Idler Genuine & General Duty

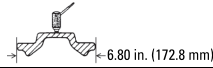
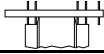

Depth Gauge		
Inches	(mm)	% Worn
0.94	(24.0)	0
0.96	(24.5)	4
0.98	(25.0)	8
1.00	(25.5)	12
1.02	(26.0)	16
1.04	(26.5)	20
1.06	(27.0)	24
1.08	(27.5)	28
1.10	(28.0)	32
1.12	(28.5)	36
1.14	(29.0)	40
1.16	(29.5)	44
1.18	(30.0)	48
1.20	(30.5)	52
1.22	(31.0)	56
1.24	(31.5)	60
1.26	(32.0)	64
1.28	(32.5)	68
1.30	(33.0)	72
1.32	(33.5)	76
1.34	(34.0)	78
1.36	(34.5)	80
1.38	(35.0)	82
1.40	(35.5)	84
1.42	(36.0)	86
1.44	(36.5)	88
1.46	(37.0)	90
1.48	(37.5)	92
1.50	(38.0)	94
1.52	(38.5)	96
1.54	(39.0)	98
1.56	(39.5)	100
1.58	(40.0)	102
1.60	(40.5)	104
1.62	(41.0)	106
1.64	(41.5)	108
1.66	(42.0)	110
1.68	(42.5)	112
1.70	(43.0)	114
1.72	(43.5)	116
1.74	(44.0)	118
1.76	(44.5)	120

Ultrasonic		Center Flange Wear	
Inches	(mm)	Inches	(mm)
0.40	(10.2)	0.00	(0.0)
0.38	(9.7)	0.02	(0.5)
0.36	(9.1)	0.04	(1.0)
0.34	(8.6)	0.06	(1.5)
0.32	(8.1)	0.08	(2.0)
0.30	(7.6)	0.10	(2.5)
0.28	(7.1)	0.12	(3.0)
0.26	(6.6)	0.14	(3.5)
0.24	(6.1)	0.16	(4.0)
0.22	(5.6)	0.18	(4.5)
0.20	(5.1)	0.20	(5.0)
0.18	(4.6)	0.22	(5.5)
0.16	(4.1)	0.24	(6.0)
0.14	(3.6)	0.26	(6.5)
0.12	(3.0)	0.28	(7.0)
0.10	(2.5)	0.30	(7.5)
0.08	(2.0)	0.32	(8.0)
0.06	(1.5)	0.34	(8.5)
0.04	(1.0)	0.36	(9.0)
0.02	(0.5)	0.38	(9.5)

### NOTE

Ultrasonic measurement is to determine flange wear only.

- 1 Flange width is 3.31 in. (84 mm)
- 2 New tread diameter is 21.26 in. (540 mm)
- 3 Wear Chart: 4385

# D5H, D5R, D6M, D6N - 7.50 in (190 mm)

**Carrier Rollers <sup>(1)</sup>**  
**SystemOne type - Permanently Sealed**  
**Current - Now used with all track types**

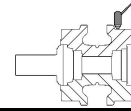
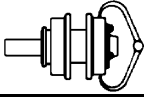

**Caliper  
All**

**Ultrasonic  
One-piece rim**

Caliper All			Ultrasonic One-piece rim		
Inches	(mm)	% Worn	Inches	(mm)	
7.16	182.0	0	1.96	49.8	
7.10	180.5	4	1.93	49.0	
7.04	179.0	8	1.90	48.3	
6.98	177.5	12	1.87	47.5	
6.92	176.0	16	1.84	46.7	
6.86	174.0	20	1.81	46.0	
6.80	172.5	24	1.78	45.2	
6.74	171.0	28	1.75	44.5	
6.68	169.5	32	1.72	43.7	
6.62	168.0	36	1.69	42.9	
6.56	166.5	40	1.66	42.2	
6.50	165.0	44	1.63	41.4	
6.44	163.5	48	1.60	40.6	
6.38	162.0	52	1.57	39.9	
6.32	160.5	56	1.54	39.1	
6.26	159.0	60	1.51	38.4	
6.20	157.5	64	1.48	37.6	
6.14	156.0	68	1.45	36.8	
6.08	154.5	72	1.42	36.1	
6.02	153.0	76	1.39	35.3	
5.96	151.5	80	1.36	34.5	
5.90	150.0	84	1.33	33.8	
5.84	148.5	88	1.30	33.0	
5.78	147.0	91	1.27	32.3	
5.72	145.5	94	1.24	31.5	
5.66	144.0	97	1.21	30.7	
5.60	142.0	100	1.18	30.0	
5.54	140.5	103	1.15	29.2	
5.48	139.0	106	1.12	28.4	
5.42	137.5	109	1.09	27.7	
5.36	136.0	112	1.06	26.9	
5.30	134.5	115	1.03	26.2	
5.24	133.0	118	1.00	25.4	
5.18	131.5	121	0.97	24.6	

1 Wear Chart: 4684

## D5H, D6M, D6N, 517 - 7.50 in. (190 mm)

### Carrier Rollers <sup>(1)</sup> Former - Bolt-On End Cover type

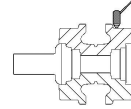
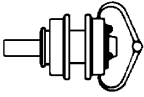

Caliper			Ultrasonic	
Inches	(mm)	% Worn	Inches	(mm)
6.75	(171.5)	0	1.55	(39.4)
6.67	(169.5)	6	1.51	(38.4)
6.59	(167.5)	12	1.47	(37.3)
6.51	(165.5)	18	1.43	(36.3)
6.43	(163.5)	24	1.39	(35.3)
6.35	(161.5)	30	1.35	(34.3)
6.27	(159.5)	36	1.31	(33.3)
6.19	(157.0)	42	1.27	(32.3)
6.11	(155.0)	48	1.23	(31.2)
6.03	(153.0)	54	1.19	(30.2)
5.95	(151.0)	60	1.15	(29.2)
5.87	(149.0)	66	1.11	(28.2)
5.79	(147.0)	72	1.07	(27.2)
5.71	(145.0)	76	1.03	(26.2)
5.63	(143.0)	80	0.99	(25.1)
5.55	(141.0)	84	0.95	(24.1)
5.47	(139.0)	88	0.91	(23.1)
5.39	(137.0)	92	0.87	(22.1)
5.31	(135.0)	96	0.83	(21.1)
5.23	(133.0)	100	0.79	(20.1)
5.15	(131.0)	104	0.75	(19.1)
5.07	(129.0)	108	0.71	(18.0)
4.99	(126.5)	112	0.67	(17.0)
4.91	(124.5)	116	0.63	(16.0)
4.83	(122.5)	120	0.59	(15.0)

# D5H, D6M, D6N, 517 - 7.50 in. (190 mm)

## Carrier Rollers <sup>(1)</sup> Use with 3T Sealed and Lubricated and Enhanced SALT Track

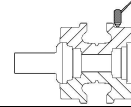
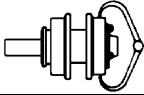

Caliper			Ultrasonic		
Inches	(mm)	% Worn	Inches	(mm)	
6.75	(171.5)	0	1.55	(39.4)	
6.71	(170.5)	4	1.53	(38.9)	
6.67	(169.5)	8	1.51	(38.4)	
6.63	(168.5)	12	1.49	(37.8)	
6.59	(167.5)	16	1.47	(37.3)	
6.55	(166.5)	20	1.45	(36.8)	
6.51	(165.5)	24	1.43	(36.3)	
6.47	(164.5)	28	1.41	(35.8)	
6.43	(163.5)	32	1.39	(35.3)	
6.39	(162.5)	36	1.37	(34.8)	
6.35	(161.5)	40	1.35	(34.3)	
6.31	(160.5)	44	1.33	(33.8)	
6.27	(159.5)	48	1.31	(33.3)	
6.23	(158.0)	52	1.29	(32.8)	
6.19	(157.0)	56	1.27	(32.3)	
6.15	(156.0)	60	1.25	(31.8)	
6.11	(155.0)	64	1.23	(31.2)	
6.07	(154.0)	68	1.21	(30.7)	
6.03	(153.0)	72	1.19	(30.2)	
5.99	(152.0)	76	1.17	(29.7)	
5.95	(151.0)	79	1.15	(29.2)	
5.91	(150.0)	82	1.13	(28.7)	
5.87	(149.0)	85	1.11	(28.2)	
5.83	(148.0)	88	1.09	(27.7)	
5.79	(147.0)	91	1.07	(27.2)	
5.75	(146.0)	94	1.05	(26.7)	
5.71	(145.0)	97	1.03	(26.2)	
5.67	(144.0)	100	1.01	(25.7)	
5.63	(143.0)	103	0.99	(25.1)	
5.59	(142.0)	106	0.97	(24.6)	
5.55	(141.0)	109	0.95	(24.1)	
5.51	(140.0)	112	0.93	(23.6)	
5.47	(139.0)	115	0.91	(23.1)	
5.43	(138.0)	118	0.89	(22.6)	
5.39	(137.0)	121	0.87	(22.1)	

1 Wear Chart: 4680

## D5H, D6M, D6N - 7.50 in. (190 mm)

### Track Rollers <sup>(1) (2)</sup> SystemOne Track

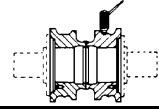
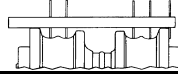

Caliper			Depth Gauge		Ultrasonic	
Inches	(mm)	% Worn	Inches	(mm)	Inches	(mm)
7.77	(197.5)	0	0.83	(21.0)	1.76	(44.7)
7.71	(196.0)	5	0.86	(22.0)	1.73	(43.9)
7.65	(194.5)	10	0.89	(22.5)	1.70	(43.2)
7.59	(193.0)	15	0.92	(23.5)	1.67	(42.4)
7.53	(191.5)	20	0.95	(24.0)	1.64	(41.7)
7.47	(189.5)	25	0.98	(25.0)	1.61	(40.9)
7.41	(188.0)	30	1.01	(25.5)	1.58	(40.1)
7.35	(186.5)	35	1.04	(26.5)	1.55	(39.4)
7.29	(185.0)	40	1.07	(27.0)	1.52	(38.6)
7.23	(183.5)	44	1.10	(28.0)	1.49	(37.8)
7.17	(182.0)	48	1.13	(28.5)	1.46	(37.1)
7.11	(180.5)	52	1.16	(29.5)	1.43	(36.3)
7.05	(179.0)	56	1.19	(30.0)	1.40	(35.6)
6.99	(177.5)	60	1.22	(31.0)	1.37	(34.8)
6.93	(176.0)	64	1.25	(32.0)	1.34	(34.0)
6.87	(174.5)	68	1.28	(32.5)	1.31	(33.3)
6.81	(173.0)	72	1.31	(33.5)	1.28	(32.5)
6.75	(171.5)	76	1.34	(34.0)	1.25	(31.8)
6.69	(170.0)	80	1.37	(35.0)	1.22	(31.0)
6.63	(168.5)	84	1.40	(35.5)	1.19	(30.2)
6.57	(167.0)	88	1.43	(36.5)	1.16	(29.5)
6.51	(165.5)	92	1.46	(37.0)	1.13	(28.7)
6.45	(164.0)	96	1.49	(38.0)	1.10	(27.9)
6.39	(162.5)	100	1.52	(38.5)	1.07	(27.2)
6.33	(161.0)	104	1.55	(39.5)	1.04	(26.4)
6.27	(159.5)	108	1.58	(40.0)	1.01	(25.7)
6.21	(157.5)	112	1.61	(41.0)	0.98	(24.9)
6.15	(156.0)	116	1.64	(41.5)	0.95	(24.1)
6.09	(154.5)	120	1.67	(42.5)	0.92	(23.4)

1 Flange diameter is 9.45 in. (240 mm)

2 Wear Chart: 5288

# D5H, D5R, D6M, D6N, 517 - 7.50 in. (190 mm)

## Track Rollers with End Collars <sup>(1)</sup> <sup>(2)</sup> Standardized Rollers

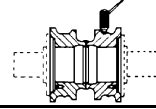
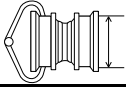

Caliper		% Worn	Depth Gauge		Ultrasonic	
Inches	(mm)		Inches	(mm)	Inches	(mm)
7.77	(197.5)	0	0.59	(15.0)	1.76	(44.7)
7.71	(196.0)	5	0.62	(15.5)	1.73	(43.9)
7.65	(194.5)	10	0.65	(16.5)	1.70	(43.2)
7.59	(193.0)	15	0.68	(17.5)	1.67	(42.4)
7.53	(191.5)	20	0.71	(18.0)	1.64	(41.7)
7.47	(189.5)	25	0.74	(19.0)	1.61	(40.9)
7.41	(188.0)	30	0.77	(19.5)	1.58	(40.1)
7.35	(186.5)	35	0.80	(20.5)	1.55	(39.4)
7.29	(185.0)	40	0.83	(21.0)	1.52	(38.6)
7.23	(183.5)	44	0.86	(22.0)	1.49	(37.8)
7.17	(182.0)	48	0.89	(22.5)	1.46	(37.1)
7.11	(180.5)	52	0.92	(23.5)	1.43	(36.3)
7.05	(179.0)	56	0.95	(24.0)	1.40	(35.6)
6.99	(177.5)	60	0.98	(25.0)	1.37	(34.8)
6.93	(176.0)	64	1.01	(25.5)	1.34	(34.0)
6.87	(174.5)	68	1.04	(26.5)	1.31	(33.3)
6.81	(173.0)	72	1.07	(27.0)	1.28	(32.5)
6.75	(171.5)	76	1.10	(28.0)	1.25	(31.8)
6.69	(170.0)	80	1.13	(28.5)	1.22	(31.0)
6.63	(168.5)	84	1.16	(29.5)	1.19	(30.2)
6.57	(167.0)	88	1.19	(30.0)	1.16	(29.5)
6.51	(165.5)	92	1.22	(31.0)	1.13	(28.7)
6.45	(164.0)	96	1.25	(32.0)	1.10	(27.9)
6.39	(162.5)	100	1.28	(32.5)	1.07	(27.2)
6.33	(161.0)	104	1.31	(33.5)	1.04	(26.4)
6.27	(159.5)	108	1.34	(34.0)	1.01	(25.7)
6.21	(157.5)	112	1.37	(35.0)	0.98	(24.9)
6.15	(156.0)	116	1.40	(35.5)	0.95	(24.1)
6.09	(154.5)	120	1.43	(36.5)	0.92	(23.4)

1 Flange diameter is 8.94 in. (227 mm)

2 Wear Chart: 5291



# D5H, D5R, D6M, D6N, 517 - 7.50 in. (190 mm)

## Track Rollers with End Collars <sup>(1)</sup> <sup>(2)</sup> General Duty

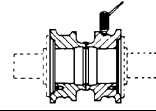
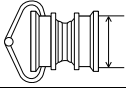

Caliper		% Worn	Depth Gauge		Ultrasonic	
Inches	(mm)		Inches	(mm)	Inches	(mm)
7.77	(197.5)	0	0.59	(15.0)	1.76	(44.7)
7.71	(196.0)	6	0.62	(15.5)	1.73	(43.9)
7.65	(194.5)	12	0.65	(16.5)	1.70	(43.2)
7.59	(193.0)	18	0.68	(17.5)	1.67	(42.4)
7.53	(191.5)	24	0.71	(18.0)	1.64	(41.7)
7.47	(189.5)	30	0.74	(19.0)	1.61	(40.9)
7.41	(188.0)	36	0.77	(19.5)	1.58	(40.1)
7.35	(186.5)	42	0.80	(20.5)	1.55	(39.4)
7.29	(185.0)	48	0.83	(21.0)	1.52	(38.6)
7.23	(183.5)	54	0.86	(22.0)	1.49	(37.8)
7.17	(182.0)	60	0.89	(22.5)	1.46	(37.1)
7.11	(180.5)	64	0.92	(23.5)	1.43	(36.3)
7.05	(179.0)	67	0.95	(24.0)	1.40	(35.6)
6.99	(177.5)	70	0.98	(25.0)	1.37	(34.8)
6.93	(176.0)	73	1.01	(25.5)	1.34	(34.0)
6.87	(174.5)	76	1.04	(26.5)	1.31	(33.3)
6.81	(173.0)	79	1.07	(27.0)	1.28	(32.5)
6.75	(171.5)	82	1.10	(28.0)	1.25	(31.8)
6.69	(170.0)	85	1.13	(28.5)	1.22	(31.0)
6.63	(168.5)	88	1.16	(29.5)	1.19	(30.2)
6.57	(167.0)	91	1.19	(30.0)	1.16	(29.5)
6.51	(165.5)	94	1.22	(31.0)	1.13	(28.7)
6.45	(164.0)	97	1.25	(32.0)	1.10	(27.9)
6.39	(162.5)	100	1.28	(32.5)	1.07	(27.2)
6.33	(161.0)	103	1.31	(33.5)	1.04	(26.4)
6.27	(159.5)	106	1.34	(34.0)	1.01	(25.7)
6.21	(157.5)	109	1.37	(35.0)	0.98	(24.9)
6.15	(156.0)	112	1.40	(35.5)	0.95	(24.1)
6.09	(154.5)	115	1.43	(36.5)	0.92	(23.4)
6.03	(153.0)	118	1.46	(37.0)	0.89	(22.6)
5.97	(151.5)	121	1.49	(38.0)	0.86	(21.8)

1 Flange diameter is 8.96 in. (227 mm)

2 Wear Chart: 5292

# D5H, D5R, D6M, D6N, 517 - 7.50 in. (190 mm)

## Tall Flange Track Rollers <sup>(1)</sup> <sup>(2)</sup> Tall Flange Double Flange Rollers

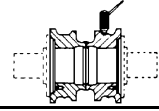
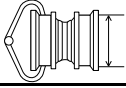

Caliper		% Worn	Depth Gauge		Ultrasonic	
Inches	(mm)		Inches	(mm)	Inches	(mm)
7.77	(197.5)	0	0.77	(19.5)	1.76	(44.7)
7.73	(196.5)	4	0.79	(20.0)	1.74	(44.2)
7.69	(195.5)	8	0.81	(20.5)	1.72	(43.7)
7.65	(194.5)	12	0.83	(21.0)	1.70	(43.2)
7.61	(193.5)	16	0.85	(21.5)	1.68	(42.7)
7.57	(192.5)	20	0.87	(22.0)	1.66	(42.2)
7.53	(191.5)	24	0.89	(22.5)	1.64	(41.7)
7.49	(190.0)	28	0.91	(23.0)	1.62	(41.1)
7.45	(189.0)	32	0.93	(23.5)	1.60	(40.6)
7.41	(188.0)	36	0.95	(24.0)	1.58	(40.1)
7.37	(187.0)	40	0.97	(24.5)	1.56	(39.6)
7.33	(186.0)	44	0.99	(25.0)	1.54	(39.1)
7.29	(185.0)	48	1.01	(25.5)	1.52	(38.6)
7.25	(184.0)	52	1.03	(26.0)	1.50	(38.1)
7.21	(183.0)	56	1.05	(26.5)	1.48	(37.6)
7.17	(182.0)	60	1.07	(27.0)	1.46	(37.1)
7.13	(181.0)	64	1.09	(27.5)	1.44	(36.6)
7.09	(180.0)	68	1.11	(28.0)	1.42	(36.1)
7.05	(179.0)	72	1.13	(28.5)	1.40	(35.6)
7.01	(178.0)	76	1.15	(29.0)	1.38	(35.1)
6.97	(177.0)	80	1.17	(29.5)	1.36	(34.5)
6.93	(176.0)	84	1.19	(30.0)	1.34	(34.0)
6.89	(175.0)	88	1.21	(30.5)	1.32	(33.5)
6.85	(174.0)	92	1.23	(31.0)	1.30	(33.0)
6.81	(173.0)	96	1.25	(32.0)	1.28	(32.5)
6.77	(172.0)	100	1.27	(32.5)	1.26	(32.0)
6.73	(171.0)	103	1.29	(33.0)	1.24	(31.5)
6.69	(170.0)	106	1.31	(33.5)	1.22	(31.0)
6.65	(169.0)	109	1.33	(34.0)	1.20	(30.5)
6.61	(168.0)	112	1.35	(34.5)	1.18	(30.0)
6.57	(167.0)	115	1.37	(35.0)	1.16	(29.5)
6.53	(166.0)	118	1.39	(35.5)	1.14	(29.0)
6.49	(165.0)	121	1.41	(36.0)	1.12	(28.4)

1 Flange diameter is 9.33 in. (237 mm)

2 Wear Chart: 6181

## D5H, D6M, D6N, 517 - 7.50 in. (190 mm)

### Track Rollers with Retainers <sup>(1) (2)</sup>

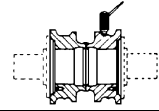
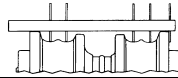
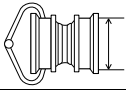

Caliper			Depth Gauge		Ultrasonic	
Inches	(mm)	% Worn	Inches	(mm)	Inches	(mm)
7.77	(197.5)	0	0.58	(14.5)	1.87	(47.5)
7.71	(196.0)	5	0.61	(15.5)	1.84	(46.7)
7.65	(194.5)	10	0.64	(16.5)	1.81	(46.0)
7.59	(193.0)	15	0.67	(17.0)	1.78	(45.2)
7.53	(191.5)	20	0.70	(18.0)	1.75	(44.5)
7.47	(189.5)	25	0.73	(18.5)	1.72	(43.7)
7.41	(188.0)	30	0.76	(19.5)	1.69	(42.9)
7.35	(186.5)	35	0.79	(20.0)	1.66	(42.2)
7.29	(185.0)	40	0.82	(21.0)	1.63	(41.4)
7.23	(183.5)	44	0.85	(21.5)	1.60	(40.6)
7.17	(182.0)	48	0.88	(22.5)	1.57	(39.9)
7.11	(180.5)	52	0.91	(23.0)	1.54	(39.1)
7.05	(179.0)	56	0.94	(24.0)	1.51	(38.4)
6.99	(177.5)	60	0.97	(24.5)	1.48	(37.6)
6.93	(176.0)	64	1.00	(25.5)	1.45	(36.8)
6.87	(174.5)	68	1.03	(26.0)	1.42	(36.1)
6.81	(173.0)	72	1.06	(27.0)	1.39	(35.3)
6.75	(171.5)	76	1.09	(27.5)	1.36	(34.5)
6.69	(170.0)	80	1.12	(28.5)	1.33	(33.8)
6.63	(168.5)	84	1.15	(29.0)	1.30	(33.0)
6.57	(167.0)	88	1.18	(30.0)	1.27	(32.3)
6.51	(165.5)	92	1.21	(30.5)	1.24	(31.5)
6.45	(164.0)	96	1.24	(31.5)	1.21	(30.7)
6.39	(162.5)	100	1.27	(32.5)	1.18	(30.0)
6.33	(161.0)	104	1.30	(33.0)	1.15	(29.2)
6.27	(159.5)	108	1.33	(34.0)	1.12	(28.4)
6.21	(157.5)	112	1.36	(34.5)	1.09	(27.7)
6.15	(156.0)	116	1.39	(35.5)	1.06	(26.9)
6.09	(154.5)	120	1.42	(36.0)	1.03	(26.2)

1 Flange diameter is 8.94 in. (227 mm)

2 Wear Chart: 5262

# D5H, D5R, D6M, D6N, 517 - 7.50 in. (190 mm)

## Sprockets <sup>(1)</sup>



Tape Measure		
Inches	(mm)	% Worn
8.45	(214.5)	0
8.40	(213.5)	6
8.35	(212.0)	12
8.30	(211.0)	18
8.25	(209.5)	24
8.20	(208.5)	30
8.15	(207.0)	35
8.10	(205.5)	40
8.05	(204.5)	45
8.00	(203.0)	50
7.95	(202.0)	55
7.90	(200.5)	60
7.85	(199.5)	65
7.80	(198.0)	70
7.75	(197.0)	75
7.70	(195.5)	80
7.65	(194.5)	85
7.60	(193.0)	90
7.55	(192.0)	95
7.50	(190.5)	100
7.45	(189.0)	105
7.40	(188.0)	110
7.35	(186.5)	115
7.30	(185.5)	120

### NOTE

Measure across 3 teeth

# D6H, D6R, D6T - 8.00 in. (203.2 mm)

## Track Links <sup>(1)</sup> SystemOne Track 234-9699

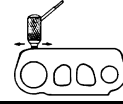
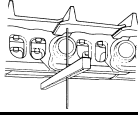

Depth Gauge			Ultrasonic	
Inches	(mm)	% Worn	Inches	(mm)
5.27	(134.0)	0	1.61	(40.9)
5.25	(133.5)	4	1.59	(40.4)
5.23	(133.0)	8	1.57	(39.9)
5.21	(132.5)	12	1.55	(39.4)
5.19	(132.0)	16	1.53	(38.9)
5.17	(131.5)	20	1.51	(38.4)
5.15	(131.0)	24	1.49	(37.8)
5.13	(130.5)	28	1.47	(37.3)
5.11	(130.0)	32	1.45	(36.8)
5.09	(129.5)	36	1.43	(36.3)
5.07	(129.0)	40	1.41	(35.8)
5.05	(128.5)	44	1.39	(35.3)
5.03	(128.0)	48	1.37	(34.8)
5.01	(127.5)	52	1.35	(34.3)
4.99	(126.5)	56	1.33	(33.8)
4.97	(126.0)	60	1.31	(33.3)
4.95	(125.5)	64	1.29	(32.8)
4.93	(125.0)	68	1.27	(32.3)
4.91	(124.5)	72	1.25	(31.8)
4.89	(124.0)	76	1.23	(31.2)
4.87	(123.5)	80	1.21	(30.7)
4.85	(123.0)	84	1.19	(30.2)
4.83	(122.5)	88	1.17	(29.7)
4.81	(122.0)	91	1.15	(29.2)
4.79	(121.5)	94	1.13	(28.7)
4.77	(121.0)	97	1.11	(28.2)
4.75	(120.5)	100	1.09	(27.7)
4.73	(120.0)	103	1.07	(27.2)
4.71	(119.5)	106	1.05	(26.7)
4.69	(119.0)	109	1.03	(26.2)
4.67	(118.5)	112	1.07	(25.7)
4.65	(118.0)	115	0.99	(25.1)
4.63	(117.5)	118	0.97	(24.6)
4.61	(117.0)	121	0.95	(24.1)

# D6H, D6R, D6T, 527 - 8.00 in. (203.2 mm)

Track Links <sup>(1)</sup>  
 Heavy Duty Track  
 Rotating Bushing Track  
 8E-7405 & 06  
 195-6515 & 16  
 378-8241 & 42

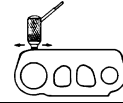
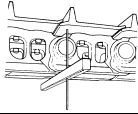

Depth Gauge			Ultrasonic	
Inches	(mm)	% Worn	Inches	(mm)
5.19	(132.0)	0	1.69	(42.9)
5.17	(131.5)	4	1.67	(42.4)
5.15	(131.0)	8	1.65	(41.9)
5.13	(130.5)	12	1.63	(41.4)
5.11	(130.0)	16	1.61	(40.9)
5.09	(129.5)	20	1.59	(40.4)
5.07	(129.0)	24	1.57	(39.9)
5.05	(128.5)	28	1.55	(39.4)
5.03	(128.0)	32	1.53	(38.9)
5.01	(127.5)	36	1.51	(38.4)
4.99	(126.5)	40	1.49	(37.8)
4.97	(126.0)	44	1.47	(37.3)
4.95	(125.5)	48	1.45	(36.8)
4.93	(125.0)	52	1.43	(36.3)
4.91	(124.5)	56	1.41	(35.8)
4.89	(124.0)	60	1.39	(35.3)
4.87	(123.5)	64	1.37	(34.8)
4.85	(123.0)	68	1.35	(34.3)
4.83	(122.5)	72	1.33	(33.8)
4.81	(122.0)	76	1.31	(33.3)
4.79	(121.5)	80	1.29	(32.8)
4.77	(121.0)	84	1.27	(32.3)
4.75	(120.5)	88	1.25	(31.8)
4.73	(120.0)	91	1.23	(31.2)
4.71	(119.5)	94	1.21	(30.7)
4.69	(119.0)	97	1.19	(30.2)
4.67	(118.5)	100	1.17	(29.7)
4.65	(118.0)	103	1.15	(29.2)
4.63	(117.5)	106	1.13	(28.7)
4.61	(117.0)	109	1.11	(28.2)
4.59	(116.5)	112	1.09	(27.7)
4.57	(116.0)	115	1.07	(27.2)
4.55	(115.5)	118	1.05	(26.7)
4.53	(115.0)	121	1.03	(26.2)

# D6H, D6R, D6T, 527 - 8.00 in. (203.2 mm)

## Track Links <sup>(1)</sup> General Duty 418-2091 & 92

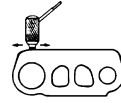
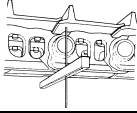

Depth Gauge			Ultrasonic	
Inches	(mm)	% Worn	Inches	(mm)
5.19	(132.0)	0	1.69	(42.9)
5.17	(131.5)	5	1.67	(42.4)
5.15	(131.0)	10	1.65	(41.9)
5.13	(130.5)	15	1.63	(41.4)
5.11	(130.0)	20	1.61	(40.9)
5.09	(129.5)	25	1.59	(40.4)
5.07	(129.0)	30	1.57	(39.9)
5.05	(128.5)	35	1.55	(39.4)
5.03	(128.0)	40	1.53	(38.9)
5.01	(127.5)	45	1.51	(38.4)
4.99	(126.5)	50	1.49	(37.8)
4.97	(126.0)	55	1.47	(37.3)
4.95	(125.5)	58	1.45	(36.8)
4.93	(125.0)	61	1.43	(36.3)
4.91	(124.5)	64	1.41	(35.8)
4.89	(124.0)	67	1.39	(35.3)
4.87	(123.5)	70	1.37	(34.8)
4.85	(123.0)	73	1.35	(34.3)
4.83	(122.5)	76	1.33	(33.8)
4.81	(122.0)	79	1.31	(33.3)
4.79	(121.5)	82	1.29	(32.8)
4.77	(121.0)	85	1.27	(32.3)
4.75	(120.5)	88	1.25	(31.8)
4.73	(120.0)	91	1.23	(31.2)
4.71	(119.5)	94	1.21	(30.7)
4.69	(119.0)	97	1.19	(30.2)
4.67	(118.5)	100	1.17	(29.7)
4.65	(118.0)	103	1.15	(29.2)
4.63	(117.5)	106	1.13	(28.7)
4.61	(117.0)	109	1.11	(28.2)
4.59	(116.5)	112	1.09	(27.7)
4.57	(116.0)	115	1.07	(27.2)
4.55	(115.5)	118	1.05	(26.7)
4.53	(115.0)	121	1.03	(26.2)

# D6H - 8.00 in. (203.2 mm)

## Track Links <sup>(1)</sup> Enhanced SALT Track 228-2735 & 36

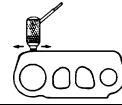
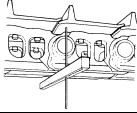

Depth Gauge			Ultrasonic	
Inches	(mm)	% Worn	Inches	(mm)
5.03	(128.0)	0	1.60	(40.6)
5.01	(127.5)	4	1.58	(40.1)
4.99	(126.5)	8	1.56	(39.6)
4.97	(126.0)	12	1.54	(39.1)
4.95	(125.5)	16	1.52	(38.6)
4.93	(125.0)	20	1.50	(38.1)
4.91	(124.5)	24	1.48	(37.6)
4.89	(124.0)	28	1.46	(37.1)
4.87	(123.5)	32	1.44	(36.6)
4.85	(123.0)	36	1.42	(36.1)
4.83	(122.5)	40	1.40	(35.6)
4.81	(122.0)	44	1.38	(35.1)
4.79	(121.5)	48	1.36	(34.5)
4.77	(121.0)	52	1.34	(34.0)
4.75	(120.5)	56	1.32	(33.5)
4.73	(120.0)	60	1.30	(33.0)
4.71	(119.5)	64	1.28	(32.5)
4.69	(119.0)	68	1.26	(32.0)
4.67	(118.5)	72	1.24	(31.5)
4.65	(118.0)	76	1.22	(31.0)
4.63	(117.5)	80	1.20	(30.5)
4.61	(117.0)	84	1.18	(30.0)
4.59	(116.5)	88	1.16	(29.5)
4.57	(116.0)	92	1.14	(29.0)
4.55	(115.5)	96	1.12	(28.4)
4.53	(115.0)	100	1.10	(27.9)
4.51	(114.5)	103	1.08	(27.4)
4.49	(114.0)	106	1.06	(26.9)
4.47	(113.5)	109	1.04	(26.4)
4.45	(113.0)	112	1.02	(25.9)
4.43	(112.5)	115	1.00	(25.4)
4.41	(112.0)	118	0.98	(24.9)
4.39	(111.5)	121	0.96	(24.4)



# D6H, D6R, 527 - 8.00 in. (203.2 mm)

## Track Links <sup>(1)</sup> Sealed & Lubricated Track 8E-2355-56

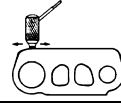
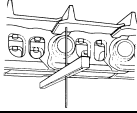

Depth Gauge			Ultrasonic	
Inches	(mm)	% Worn	Inches	(mm)
4.92	(125.0)	0	1.46	(37.1)
4.90	(124.5)	5	1.44	(36.6)
4.88	(124.0)	10	1.42	(36.1)
4.86	(123.5)	15	1.40	(35.6)
4.84	(123.0)	20	1.38	(35.1)
4.82	(122.5)	25	1.36	(34.5)
4.80	(122.0)	30	1.34	(34.0)
4.78	(121.5)	35	1.32	(33.5)
4.76	(121.0)	40	1.30	(33.0)
4.74	(120.5)	45	1.28	(32.5)
4.72	(120.0)	50	1.26	(32.0)
4.70	(119.5)	55	1.24	(31.5)
4.68	(119.0)	60	1.22	(31.0)
4.66	(118.5)	65	1.20	(30.5)
4.64	(118.0)	70	1.18	(30.0)
4.62	(117.5)	75	1.16	(29.5)
4.60	(117.0)	80	1.14	(29.0)
4.58	(116.5)	85	1.12	(28.4)
4.56	(116.0)	90	1.10	(27.9)
4.54	(115.5)	95	1.08	(27.4)
4.52	(115.0)	100	1.06	(26.9)
4.50	(114.5)	104	1.04	(26.4)
4.48	(114.0)	108	1.02	(25.9)
4.46	(113.5)	112	1.00	(25.4)
4.44	(113.0)	116	0.98	(24.9)
4.42	(112.5)	120	0.96	(24.4)

# D6H, D6R, D6T - 8.00 in. (203.2 mm)

## Bushings <sup>(1)</sup> SystemOne Track

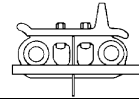
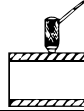

Caliper			Ultrasonic		Depth Gauge	
Inches	(mm)	% Worn	Inches	(mm)	Inches	(mm)
2.86	(72.6)	0	0.55	(14.0)	3.63	(92.2)
2.84	(72.1)	6	0.54	(13.7)	3.62	(91.9)
2.82	(71.6)	12	0.53	(13.5)	3.61	(91.7)
2.80	(71.1)	18	0.52	(13.2)	3.60	(91.4)
2.78	(70.6)	24	0.51	(13.0)	3.59	(91.2)
2.76	(70.1)	30	0.50	(12.7)	3.58	(90.9)
2.74	(69.6)	36	0.49	(12.4)	3.57	(90.7)
2.72	(69.1)	42	0.48	(12.2)	3.56	(90.4)
2.70	(68.6)	46	0.47	(11.9)	3.55	(90.2)
2.68	(68.1)	49	0.46	(11.7)	3.54	(89.9)
2.66	(67.6)	52	0.45	(11.4)	3.53	(89.7)
2.64	(67.1)	55	0.44	(11.2)	3.52	(89.4)
2.62	(66.5)	58	0.43	(10.9)	3.51	(89.2)
2.60	(66.0)	61	0.42	(10.7)	3.50	(88.9)
2.58	(65.5)	64	0.41	(10.4)	3.49	(88.6)
2.56	(65.0)	67	0.40	(10.2)	3.48	(88.4)
2.54	(64.5)	70	0.39	(9.9)	3.47	(88.1)
2.52	(64.0)	73	0.38	(9.7)	3.46	(87.9)
2.50	(63.5)	76	0.37	(9.4)	3.45	(87.6)
2.48	(63.0)	79	0.36	(9.1)	3.44	(87.4)
2.46	(62.5)	82	0.35	(8.9)	3.43	(87.1)
2.44	(62.0)	85	0.34	(8.6)	3.42	(86.9)
2.42	(61.5)	88	0.33	(8.4)	3.41	(86.6)
2.40	(61.0)	91	0.32	(8.1)	3.40	(86.4)
2.38	(60.5)	94	0.31	(7.9)	3.39	(86.1)
2.36	(59.9)	97	0.30	(7.6)	3.38	(85.9)
2.34	(59.4)	100	0.29	(7.4)	3.37	(85.6)
2.32	(58.9)	103	0.28	(7.1)	3.36	(85.3)
2.30	(58.4)	106	0.27	(6.9)	3.35	(85.1)
2.28	(57.9)	109	0.26	(6.6)	3.34	(84.8)
2.26	(57.4)	112	0.25	(6.3)	3.33	(84.6)
2.24	(56.9)	115	0.24	(6.1)	3.32	(84.3)
2.22	(56.4)	118	0.23	(5.8)	3.31	(84.1)
2.20	(55.9)	121	0.22	(5.6)	3.30	(83.8)

**NOTE**

Due to SystemOne cartridge product improvement in 2010 to add strength and resist cracking, Ultrasonic measurement 'New/0% Worn' increased from .50 in. (12.7 mm) to .55 in. (14 mm)

# D6H, D6R, D6T, 527 - 8.00 in. (203.2 mm)

## Bushings <sup>(1)</sup> Heavy Duty Track Use with 8E-7405 & 06 or 378-8241 & 42 Links

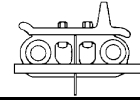
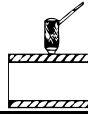
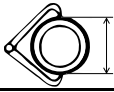

Caliper		Allowable Wear		Ultrasonic		Depth Gauge	
Inches	(mm)	Lesser % Worn	Greater % Worn	Inches	(mm)	Inches	(mm)
2.86	(72.6)	0	0	0.53	(13.5)	3.52	(89.4)
2.84	(72.1)	10	8	0.51	(13.0)	3.50	(88.9)
2.82	(71.6)	20	16	0.49	(12.4)	3.48	(88.4)
2.80	(71.1)	30	24	0.47	(11.9)	3.46	(87.9)
2.78	(70.6)	40	32	0.45	(11.4)	3.44	(87.4)
2.76	(70.1)	50	40	0.43	(10.9)	3.42	(86.9)
2.74	(69.6)	60	48	0.41	(10.4)	3.40	(86.4)
2.72	(69.1)	70	52	0.39	(9.9)	3.38	(85.9)
2.70	(68.6)	76	56	0.37	(9.4)	3.36	(85.3)
2.68	(68.1)	80	60	0.35	(8.9)	3.34	(84.8)
2.66	(67.6)	84	64	0.33	(8.4)	3.32	(84.3)
2.64	(67.1)	88	68	0.31	(7.9)	3.30	(83.8)
2.62	(66.5)	92	72	0.29	(7.4)	3.28	(83.3)
2.60	(66.0)	96	76	0.27	(6.9)	3.26	(82.8)
2.58	(65.5)	100	80	0.25	(6.3)	3.24	(82.3)
2.56	(65.0)	104	84	0.23	(5.8)	3.22	(81.8)
2.54	(64.5)	108	88	0.21	(5.3)	3.20	(81.3)
2.52	(64.0)	112	92	0.19	(4.8)	3.18	(80.8)
2.50	(63.5)	116	96	0.17	(4.3)	3.16	(80.3)
2.48	(63.0)	120	100	0.15	(3.8)	3.14	(79.8)
2.46	(62.5)		104	0.13	(3.3)	3.12	(79.2)
2.44	(62.0)		108	0.11	(2.8)	3.10	(78.7)
2.42	(61.5)		112	0.09	(2.3)	3.08	(78.2)
2.40	(61.0)		116	0.07	(1.8)	3.06	(77.7)
2.38	(60.5)		120	0.05	(1.3)	3.04	(77.2)

**Note: Do Not Use Depth Gauge Until Bushings Have Been "Turned."**

# D6H, D6R, D6T, 527 - 8.00 in. (203.2 mm)

**Bushings <sup>(1)</sup>**  
**Heavy Duty Track**  
**Use with 527 with Optional Large Diameter Bushing**

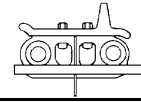
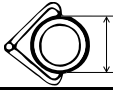

Caliper		Allowable Wear		Ultrasonic		Depth Gauge	
Inches	(mm)	Lesser % Worn	Greater % Worn	Inches	(mm)	Inches	(mm)
3.15	(80.0)	0	0	0.68	(17.3)	3.70	(94.0)
3.13	(79.5)	6	5	0.66	(16.8)	3.68	(93.5)
3.11	(79.0)	12	10	0.64	(16.3)	3.66	(93.0)
3.09	(78.5)	18	15	0.62	(15.7)	3.64	(92.5)
3.07	(78.0)	24	20	0.60	(15.2)	3.62	(91.9)
3.05	(77.5)	30	25	0.58	(14.7)	3.60	(91.4)
3.03	(77.0)	36	30	0.56	(14.2)	3.58	(90.9)
3.01	(76.5)	40	35	0.54	(13.7)	3.56	(90.4)
2.99	(75.9)	44	40	0.52	(13.2)	3.54	(89.9)
2.97	(75.4)	48	45	0.50	(12.7)	3.52	(89.4)
2.95	(74.9)	52	49	0.48	(12.2)	3.50	(88.9)
2.93	(74.4)	56	52	0.46	(11.7)	3.48	(88.4)
2.91	(73.9)	60	55	0.44	(11.2)	3.46	(87.9)
2.89	(73.4)	64	58	0.42	(10.7)	3.44	(87.4)
2.87	(72.9)	68	61	0.40	(10.2)	3.42	(86.9)
2.85	(72.4)	72	64	0.38	(9.7)	3.40	(86.4)
2.83	(71.9)	76	67	0.36	(9.1)	3.38	(85.9)
2.81	(71.4)	80	70	0.34	(8.6)	3.36	(85.3)
2.79	(70.9)	84	73	0.32	(8.1)	3.34	(84.8)
2.77	(70.4)	88	76	0.30	(7.6)	3.32	(84.3)
2.75	(69.9)	92	79	0.28	(7.1)	3.30	(83.8)
2.73	(69.3)	96	82	0.26	(6.6)	3.28	(83.3)
2.71	(68.8)	100	85	0.24	(6.1)	3.26	(82.8)
2.69	(68.3)	104	88	0.22	(5.6)	3.24	(82.3)
2.67	(67.8)	108	91	0.20	(5.1)	3.22	(81.8)
2.65	(67.3)	112	94	0.18	(4.6)	3.20	(81.3)
2.63	(66.8)	116	97	0.16	(4.1)	3.18	(80.8)
2.61	(66.3)	120	100	0.14	(3.6)	3.16	(80.3)
2.59	(65.8)		103	0.12	(3.0)	3.14	(79.8)
2.57	(65.3)		106	0.10	(2.5)	3.12	(79.2)
2.55	(64.8)		109	0.08	(2.0)	3.10	(78.7)
2.53	(64.3)		112	0.06	(1.5)	3.08	(78.2)
2.51	(63.8)		115	0.04	(1.0)	3.06	(77.7)
2.49	(63.2)		118	0.02	(0.5)	3.04	(77.2)
2.47	(62.7)		121	0.00	(0.0)	3.02	(76.7)

**Note: Do Not Use Depth Gauge Until Bushings Have Been "Turned."**

1 Wear Chart: 707

# D6H, D6R, D6T, 527 - 8.00 in. (203.2 mm)

## Bushings <sup>(1)</sup> Rotating Bushing Track Use with 195-6515 & 16, 8E-7405 & 06 Links

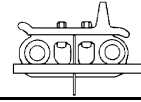
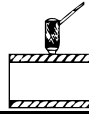
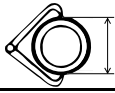

Caliper			Ultrasonic		Depth Gauge	
Inches	(mm)	% Worn	Inches	(mm)	Inches	(mm)
2.86	(72.6)	0	0.55	(14.0)	3.56	(90.4)
2.82	(71.6)	8	0.53	(13.5)	3.54	(89.9)
2.78	(70.6)	16	0.51	(13.0)	3.52	(89.4)
2.74	(69.6)	24	0.49	(12.4)	3.50	(88.9)
2.70	(68.6)	32	0.47	(11.9)	3.48	(88.4)
2.66	(67.6)	40	0.45	(11.4)	3.46	(87.9)
2.62	(66.5)	44	0.43	(10.9)	3.44	(87.4)
2.58	(65.5)	48	0.41	(10.4)	3.42	(86.9)
2.54	(64.5)	52	0.39	(9.9)	3.40	(86.4)
2.50	(63.5)	56	0.37	(9.4)	3.38	(85.9)
2.46	(62.5)	60	0.35	(8.9)	3.36	(85.3)
2.42	(61.5)	64	0.33	(8.4)	3.34	(84.8)
2.38	(60.5)	68	0.31	(7.9)	3.32	(84.3)
2.34	(59.4)	72	0.29	(7.4)	3.30	(83.8)
2.30	(58.4)	76	0.27	(6.9)	3.28	(83.3)
2.26	(57.4)	80	0.25	(6.3)	3.26	(82.8)
2.22	(56.4)	84	0.23	(5.8)	3.24	(82.3)
2.18	(55.4)	88	0.21	(5.3)	3.22	(81.8)
2.14	(54.4)	92	0.19	(4.8)	3.20	(81.3)
2.10	(53.3)	96	0.17	(4.3)	3.18	(80.8)
2.06	(52.3)	100	0.15	(3.8)	3.16	(80.3)
2.02	(51.3)	104	0.13	(3.3)	3.14	(79.8)
1.98	(50.3)	108	0.11	(2.8)	3.12	(79.2)
1.94	(49.3)	112	0.09	(2.3)	3.10	(78.7)
1.90	(48.3)	116	0.07	(1.8)	3.08	(78.2)
1.86	(47.2)	120	0.05	(1.3)	3.06	(77.7)

# D6H, D6R, D6T, 527 - 8.00 in. (203.2 mm)

**Bushings <sup>(1)</sup>**  
**General Duty**  
 Use with 418-2091 & 92 Links

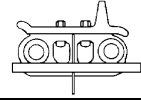
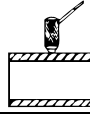

Caliper			Ultrasonic		Depth Gauge	
Inches	(mm)	% Worn	Inches	(mm)	Inches	(mm)
2.86	(72.6)	0	0.53	(13.5)	3.52	(89.4)
2.84	(72.1)	10	0.51	(13.0)	3.50	(88.9)
2.82	(71.6)	20	0.49	(12.4)	3.48	(88.4)
2.80	(71.1)	30	0.47	(11.9)	3.46	(87.9)
2.78	(70.6)	40	0.45	(11.4)	3.44	(87.4)
2.76	(70.1)	50	0.43	(10.9)	3.42	(86.9)
2.74	(69.6)	60	0.41	(10.4)	3.40	(86.4)
2.72	(69.1)	64	0.39	(9.9)	3.38	(85.9)
2.70	(68.6)	67	0.37	(9.4)	3.36	(85.3)
2.68	(68.1)	70	0.35	(8.9)	3.34	(84.8)
2.66	(67.6)	73	0.33	(8.4)	3.32	(84.3)
2.64	(67.1)	76	0.31	(7.9)	3.30	(83.8)
2.62	(66.5)	79	0.29	(7.4)	3.28	(83.3)
2.60	(66.0)	82	0.27	(6.9)	3.26	(82.8)
2.58	(65.5)	85	0.25	(6.3)	3.24	(82.3)
2.56	(65.0)	88	0.23	(5.8)	3.22	(81.8)
2.54	(64.5)	91	0.21	(5.3)	3.20	(81.3)
2.52	(64.0)	94	0.19	(4.8)	3.18	(80.8)
2.50	(63.5)	97	0.17	(4.3)	3.16	(80.3)
2.48	(63.0)	100	0.15	(3.8)	3.14	(79.8)
2.46	(62.5)	103	0.13	(3.3)	3.12	(79.2)
2.44	(62.0)	106	0.11	(2.8)	3.10	(78.7)
2.42	(61.5)	109	0.09	(2.3)	3.08	(78.2)
2.40	(61.0)	112	0.07	(1.8)	3.06	(77.7)
2.38	(60.5)	115	0.05	(1.3)	3.04	(77.2)
2.36	(59.9)	118	0.03	(0.8)	3.02	(76.7)
2.34	(59.4)	121	0.01	(0.3)	3.00	(76.2)

1 Wear Chart: 713

**Bushings<sup>(1)</sup>  
Enhanced SALT Track**

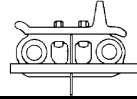

Caliper		Lesser % Worn	Greater % Worn	Ultrasonic		Depth Gauge	
Inches	(mm)			Inches	(mm)	Inches	(mm)
2.86	(72.6)	0	0	0.53	(13.5)	3.49	(88.6)
2.84	(72.1)	10	8	0.51	(13.0)	3.47	(88.1)
2.82	(71.6)	20	16	0.49	(12.4)	3.45	(87.6)
2.80	(71.1)	30	24	0.47	(11.9)	3.43	(87.1)
2.78	(70.6)	40	32	0.45	(11.4)	3.41	(86.6)
2.76	(70.1)	50	40	0.43	(10.9)	3.39	(86.1)
2.74	(69.6)	60	48	0.41	(10.4)	3.37	(85.6)
2.72	(69.1)	70	52	0.39	(9.9)	3.35	(85.1)
2.70	(68.6)	76	56	0.37	(9.4)	3.33	(84.6)
2.68	(68.1)	80	60	0.35	(8.9)	3.31	(84.1)
2.66	(67.6)	84	64	0.33	(8.4)	3.29	(83.6)
2.64	(67.1)	88	68	0.31	(7.9)	3.27	(83.1)
2.62	(66.5)	92	72	0.29	(7.4)	3.25	(82.6)
2.60	(66.0)	96	76	0.27	(6.9)	3.23	(82.0)
2.58	(65.5)	100	80	0.25	(6.3)	3.21	(81.5)
2.56	(65.0)	104	84	0.23	(5.8)	3.19	(81.0)
2.54	(64.5)	108	88	0.21	(5.3)	3.17	(80.5)
2.52	(64.0)	112	92	0.19	(4.8)	3.15	(80.0)
2.50	(63.5)	116	96	0.17	(4.3)	3.13	(79.5)
2.48	(63.0)	120	100	0.15	(3.8)	3.11	(79.0)
2.46	(62.5)		104	0.13	(3.3)	3.09	(78.5)
2.44	(62.0)		108	0.11	(2.8)	3.07	(78.0)
2.42	(61.5)		112	0.09	(2.3)	3.05	(77.5)
2.40	(61.0)		116	0.07	(1.8)	3.03	(77.0)
2.38	(60.5)		120	0.05	(1.3)	3.01	(76.5)

**Note: Do Not Use Depth Gauge Until Bushings Have Been "Turned."**

# D6H, D6R, D6T, 527 - 8.00 in. (203.2 mm)

**Bushings <sup>(1)</sup>**  
**Sealed and Lubricated Track**  
**Use with 8E-2355 & 56**

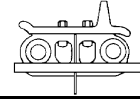
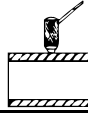

Caliper		Lesser % Worn	Greater % Worn	Ultrasonic		Depth Gauge	
Inches	(mm)			Inches	(mm)	Inches	(mm)
2.86	(72.6)	0	0	0.53	(13.5)	3.52	(89.4)
2.84	(72.1)	10	8	0.51	(13.0)	3.50	(88.9)
2.82	(71.6)	20	16	0.49	(12.4)	3.48	(88.4)
2.80	(71.1)	30	24	0.47	(11.9)	3.46	(87.9)
2.78	(70.6)	40	32	0.45	(11.4)	3.44	(87.4)
2.76	(70.1)	50	40	0.43	(10.9)	3.42	(86.9)
2.74	(69.6)	60	48	0.41	(10.4)	3.40	(86.4)
2.72	(69.1)	70	52	0.39	(9.9)	3.38	(85.9)
2.70	(68.6)	76	56	0.37	(9.4)	3.36	(85.3)
2.68	(68.1)	80	60	0.35	(8.9)	3.34	(84.8)
2.66	(67.6)	84	64	0.33	(8.4)	3.32	(84.3)
2.64	(67.1)	88	68	0.31	(7.9)	3.30	(83.8)
2.62	(66.5)	92	72	0.29	(7.4)	3.28	(83.3)
2.60	(66.0)	96	76	0.27	(6.9)	3.26	(82.8)
2.58	(65.5)	100	80	0.25	(6.3)	3.24	(82.3)
2.56	(65.0)	104	84	0.23	(5.8)	3.22	(81.8)
2.54	(64.5)	108	88	0.21	(5.3)	3.20	(81.3)
2.52	(64.0)	112	92	0.19	(4.8)	3.18	(80.8)
2.50	(63.5)	116	96	0.17	(4.3)	3.16	(80.3)
2.48	(63.0)	120	100	0.15	(3.8)	3.14	(79.8)
2.46	(62.5)		104	0.13	(3.3)	3.12	(79.2)
2.44	(62.0)		108	0.11	(2.8)	3.10	(78.7)
2.42	(61.5)		112	0.09	(2.3)	3.08	(78.2)
2.40	(61.0)		116	0.07	(1.8)	3.06	(77.7)
2.38	(60.5)		120	0.05	(1.3)	3.04	(77.2)

**Note: Do Not Use Depth Gauge Until Bushings Have Been "Turned."**



# D6H, D6R, D6T, 527 - 8.00 in. (203.2 mm)

## Track Shoes <sup>(1)</sup> Extreme Service

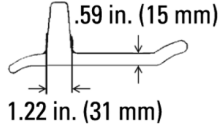
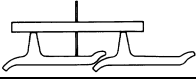

Depth Gauge		High Impact	Low/Moderate	Ultrasonic	
Inches	(mm)	% Worn	Impact % Worn	Inches	(mm)
2.95	(75.0)	0	0	3.55	(90.2)
2.85	(72.5)	8	6	3.45	(87.6)
2.75	(70.0)	16	12	3.35	(85.1)
2.65	(67.5)	24	18	3.25	(82.6)
2.55	(65.0)	32	24	3.15	(80.0)
2.45	(62.0)	40	30	3.05	(77.5)
2.35	(59.5)	48	36	2.95	(74.9)
2.30	(58.5)	52	39	2.90	(73.7)
2.20	(56.0)	58	45	2.80	(71.1)
2.10	(53.5)	64	51	2.70	(68.6)
2.00	(51.0)	70	57	2.60	(66.0)
1.90	(48.5)	76	63	2.50	(63.5)
1.80	(45.5)	82	68	2.40	(61.0)
1.70	(43.0)	88	72	2.30	(58.4)
1.60	(40.5)	94	76	2.20	(55.9)
1.50	(38.0)	100	80	2.10	(53.3)
1.40	(35.5)	106	84	2.00	(50.8)
1.30	(33.0)	112	88	1.90	(48.3)
1.20	(30.5)	118	92	1.80	(45.7)
1.10	(28.0)	124	96	1.70	(43.2)
1.00	(25.5)		100	1.60	(40.6)
0.90	(23.0)		104	1.50	(38.1)
0.80	(20.5)		108	1.40	(35.6)
0.70	(18.0)		112	1.30	(33.0)
0.60	(15.0)		116	1.20	(30.5)
0.50	(12.5)		120	1.10	(27.9)

# D6H, D6R, D6T, 527 - 8.00 in. (203.2 mm)

## Track Shoes <sup>(1)</sup> Moderate Service Genuine and General Duty

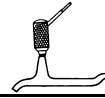
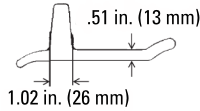
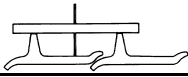

Depth Gauge		High Impact	Low/Moderate	Ultrasonic	
Inches	(mm)	% Worn	Impact % Worn	Inches	(mm)
2.55	(65.0)	0	0	3.05	(77.5)
2.50	(63.5)	5	4	3.00	(76.2)
2.45	(62.0)	10	8	2.95	(74.9)
2.40	(61.0)	15	12	2.90	(73.7)
2.35	(59.5)	20	16	2.85	(72.4)
2.30	(58.5)	25	20	2.80	(71.1)
2.25	(57.0)	30	24	2.75	(69.9)
2.20	(56.0)	35	28	2.70	(68.6)
2.15	(54.5)	40	31	2.65	(67.3)
2.10	(53.5)	45	34	2.60	(66.0)
2.05	(52.0)	50	37	2.55	(64.8)
2.00	(51.0)	55	40	2.50	(63.5)
1.95	(49.5)	60	43	2.45	(62.2)
1.90	(48.5)	65	46	2.40	(61.0)
1.85	(47.0)	70	49	2.35	(59.7)
1.80	(45.5)	75	52	2.30	(58.4)
1.75	(44.5)	80	55	2.25	(57.2)
1.70	(43.0)	84	58	2.20	(55.9)
1.65	(42.0)	88	61	2.15	(54.6)
1.60	(40.5)	92	64	2.10	(53.3)
1.55	(39.5)	96	67	2.05	(52.1)
1.50	(38.0)	100	70	2.00	(50.8)
1.45	(37.0)	104	73	1.95	(49.5)
1.40	(35.5)	108	76	1.90	(48.3)
1.35	(34.5)	112	79	1.85	(47.0)
1.30	(33.0)	116	82	1.80	(45.7)
1.25	(32.0)	120	85	1.75	(44.5)
1.20	(30.5)		88	1.70	(43.2)
1.15	(29.0)		91	1.65	(41.9)
1.10	(28.0)		94	1.60	(40.6)
1.05	(26.5)		97	1.55	(39.4)
1.00	(25.5)		100	1.50	(38.1)
0.95	(24.0)		103	1.45	(36.8)
0.90	(23.0)		106	1.40	(35.6)
0.85	(21.5)		109	1.35	(34.3)
0.80	(20.5)		112	1.30	(33.0)
0.75	(19.0)		115	1.25	(31.8)
0.70	(18.0)		118	1.20	(30.5)
0.65	(16.5)		121	1.15	(29.2)

## D6H, D6R, D6T, 527 - 8.00 in. (203.2 mm)

### Track Shoes <sup>(1)</sup> Double Grouser

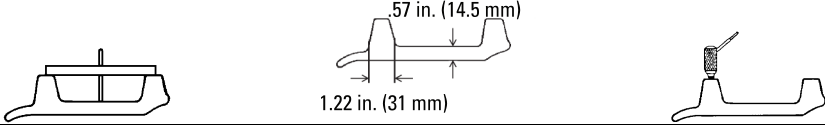

Depth Gauge		High Impact	Low/Moderate	Ultrasonic	
Inches	(mm)	% Worn	Impact % Worn	Inches	(mm)
1.65	(42.0)	0	0	2.20	(55.9)
1.60	(40.5)	6	5	2.15	(54.6)
1.55	(39.5)	12	10	2.10	(53.3)
1.50	(38.0)	18	15	2.05	(52.1)
1.45	(37.0)	24	20	2.00	(50.8)
1.40	(35.5)	30	25	1.95	(49.5)
1.35	(34.5)	36	30	1.90	(48.3)
1.30	(33.0)	42	35	1.85	(47.0)
1.25	(32.0)	48	40	1.80	(45.7)
1.20	(30.5)	54	44	1.75	(44.5)
1.15	(29.0)	60	48	1.70	(43.2)
1.10	(28.0)	65	52	1.65	(41.9)
1.05	(26.5)	70	56	1.60	(40.6)
1.00	(25.5)	75	60	1.55	(39.4)
0.95	(24.0)	80	64	1.50	(38.1)
0.90	(23.0)	85	68	1.45	(36.8)
0.85	(21.5)	90	72	1.40	(35.6)
0.80	(20.5)	95	76	1.35	(34.3)
0.75	(19.0)	100	80	1.30	(33.0)
0.70	(18.0)	105	84	1.25	(31.8)
0.65	(16.5)	110	88	1.20	(30.5)
0.60	(15.0)	115	92	1.15	(29.2)
0.55	(14.0)	120	96	1.10	(27.9)
0.50	(12.5)		100	1.05	(26.7)
0.45	(11.5)		104	1.00	(25.4)
0.40	(10.0)		108	0.95	(24.1)
0.35	(9.0)		112	0.90	(22.9)
0.30	(7.5)		116	0.85	(21.6)
0.25	(6.5)		120	0.80	(20.3)

# D6H, D6R, D6T - 8.00 in. (203.2 mm)

Track Shoes <sup>(1)</sup>  
Self Cleaning



Depth Gauge

Inches	(mm)	% Worn
3.61	(91.5)	0
3.59	(91.0)	4
3.57	(90.5)	8
3.55	(90.0)	12
3.53	(89.5)	16
3.51	(89.0)	20
3.49	(88.5)	24
3.47	(88.0)	28
3.45	(87.5)	32
3.43	(87.0)	36
3.41	(86.5)	40
3.39	(86.0)	44
3.37	(85.5)	48
3.35	(85.0)	52
3.33	(84.5)	55
3.31	(84.0)	58
3.29	(83.5)	61
3.27	(83.0)	64
3.25	(82.5)	67
3.23	(82.0)	70
3.21	(81.5)	73
3.19	(81.0)	76
3.17	(80.5)	79
3.15	(80.0)	82
3.13	(79.5)	85
3.11	(79.0)	88
3.09	(78.5)	91
3.07	(78.0)	94
3.05	(77.5)	97
3.03	(77.0)	100
3.01	(76.5)	103
2.99	(76.0)	106
2.97	(75.5)	109
2.95	(75.0)	112
2.93	(74.5)	115
2.91	(74.0)	118
2.89	(73.5)	121

1 Wear Chart: 1900

# D6H, D6R, D6T - 8.00 in. (203.2 mm)

## Idlers <sup>(1)</sup> <sup>(2)</sup> <sup>(3)</sup>

### Relieved Tread Idler

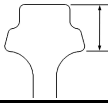

### Center Tread Idler

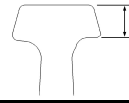

Depth Gauge, Ultrasonic (CTI only) or Caliper				
Inches	(mm)	% Worn	Inches	(mm)
2.12	(54.0)	0	1.10	(28.0)
2.10	(53.5)	4	1.08	(27.5)
2.08	(53.0)	8	1.06	(27.0)
2.06	(52.5)	12	1.04	(26.5)
2.04	(52.0)	16	1.02	(26.0)
2.02	(51.5)	20	1.00	(25.5)
2.00	(51.0)	24	0.98	(25.0)
1.98	(50.5)	28	0.96	(24.5)
1.96	(50.0)	32	0.94	(24.0)
1.94	(49.5)	36	0.92	(23.5)
1.92	(49.0)	40	0.90	(23.0)
1.90	(48.5)	44	0.88	(22.5)
1.88	(48.0)	48	0.86	(22.0)
1.86	(47.0)	52	0.84	(21.5)
1.84	(46.5)	55	0.82	(21.0)
1.82	(46.0)	58	0.80	(20.5)
1.80	(45.5)	61	0.78	(20.0)
1.78	(45.0)	64	0.76	(19.5)
1.76	(44.5)	67	0.74	(19.0)
1.74	(44.0)	70	0.72	(18.5)
1.72	(43.5)	73	0.70	(18.0)
1.70	(43.0)	76	0.68	(17.5)
1.68	(42.5)	79	0.66	(17.0)
1.66	(42.0)	82	0.64	(16.5)
1.64	(41.5)	85	0.62	(15.5)
1.62	(41.0)	88	0.60	(15.0)
1.60	(40.5)	91	0.58	(14.5)
1.58	(40.0)	94	0.56	(14.0)
1.56	(39.5)	97	0.54	(13.5)
1.54	(39.0)	100	0.52	(13.0)
1.52	(38.5)	103	0.50	(12.5)
1.50	(38.0)	106	0.48	(12.0)
1.48	(37.5)	109	0.46	(11.5)
1.46	(37.0)	112	0.44	(11.0)
1.44	(36.5)	115	0.42	(10.5)
1.42	(36.0)	118	0.40	(10.0)
1.40	(35.5)	121	0.38	(9.5)

1 New tread diameter is 25.40 in. (640 mm)

2 For measuring instructions, reference General Information topic *Idler Wear – Center Tread Idlers and Relieved Center Tread Idlers* on, page 51.

3 Wear Chart: 4101

# D6H, D6R, D6T - 8.00 in. (203.2 mm)

**Idlers <sup>(1)</sup> <sup>(2)</sup>**  
**Center Tread Idler**  
**(Early — has eight measurement notches)**

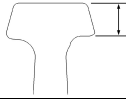

**Ultrasonic, Depth Gauge or Caliper**

Inches	(mm)	% Worn
0.94	(24.0)	0
0.92	(23.5)	5
0.90	(23.0)	10
0.88	(22.5)	15
0.86	(22.0)	20
0.84	(21.5)	25
0.82	(21.0)	30
0.80	(20.5)	34
0.78	(20.0)	37
0.76	(19.5)	40
0.74	(19.0)	43
0.72	(18.5)	46
0.70	(18.0)	49
0.68	(17.5)	52
0.66	(17.0)	55
0.64	(16.5)	58
0.62	(15.5)	61
0.60	(15.0)	64
0.58	(14.5)	67
0.56	(14.0)	70
0.54	(13.5)	73
0.52	(13.0)	76
0.50	(12.5)	79
0.48	(12.0)	82
0.46	(11.5)	85
0.44	(11.0)	88
0.42	(10.5)	91
0.40	(10.0)	94
0.38	(9.5)	97
0.36	(9.0)	100
0.34	(8.5)	103
0.32	(8.0)	106
0.30	(7.5)	109
0.28	(7.0)	112
0.26	(6.5)	115
0.24	(6.0)	118
0.22	(5.5)	121

**Note:** New tread diameter is 25.20 in. (640 mm)

- 1 For measuring instructions, reference General Information topic *Idler Wear – Center Tread Idlers on, page 51.*
- 2 Wear Chart: 4102

## D6H, D6R, D6T, 527 - 8.00 in. (203.2 mm)

### Idlers (1) (2) (3) (4) Genuine and General Duty

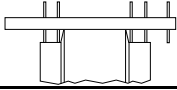

**Depth Gauge**

Inches	(mm)	% Worn
0.94	(24.0)	0
0.98	(25.0)	8
1.02	(26.0)	16
1.06	(27.0)	24
1.10	(28.0)	32
1.14	(29.0)	40
1.18	(30.0)	48
1.22	(31.0)	52
1.26	(32.0)	56
1.30	(33.0)	60
1.34	(34.0)	64
1.38	(35.0)	68
1.42	(36.0)	72
1.46	(37.0)	76
1.50	(38.0)	80
1.54	(39.0)	84
1.58	(40.0)	88
1.62	(41.0)	92
1.66	(42.0)	96
1.70	(43.0)	100
1.74	(44.0)	104
1.78	(45.0)	108
1.82	(46.0)	112
1.86	(47.0)	116
1.90	(48.5)	120

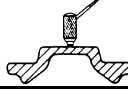

**Ultrasonic**

**Center Flange Wear**

Inches	(mm)	Inches	(mm)
0.49	(12.4)	0.00	(0.0)
0.45	(11.4)	0.04	(1.0)
0.41	(10.4)	0.08	(2.0)
0.37	(9.4)	0.12	(3.0)
0.33	(8.4)	0.16	(4.0)
0.29	(7.4)	0.20	(5.0)
0.25	(6.4)	0.24	(6.0)
0.21	(5.3)	0.28	(7.0)
0.17	(4.3)	0.32	(8.0)
0.13	(3.3)	0.36	(9.0)
0.09	(2.3)	0.40	(10.0)
0.05	(1.3)	0.44	(11.0)
0.01	(0.3)	0.48	(12.0)

**NOTE**

Ultrasonic measurement is to determine flange wear only.

- 1 Flange Width is 3.74 in. (95 mm)
- 2 New small tread diameter is 21.46 in. (545 mm)
- 3 New large tread diameter is 22.44 in. (570 mm)
- 4 Wear Chart: 4406

# D6H, D6R, D6T, 527 - 8.00 in. (203.2 mm)

## Carrier Rollers <sup>(1)</sup> SystemOne type - Permanently Sealed Current - Now used with all track types

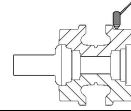
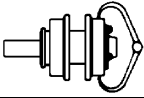

**Caliper  
All**

**Ultrasonic  
One-piece rim**

Inches	(mm)	% Worn	Inches	(mm)
7.84	(199.0)	0	2.31	(58.7)
7.76	(197.0)	8	2.27	(57.7)
7.68	(195.0)	16	2.23	(56.6)
7.60	(193.0)	24	2.19	(55.6)
7.52	(191.0)	32	2.15	(54.6)
7.44	(189.0)	40	2.11	(53.6)
7.36	(187.0)	44	2.07	(52.6)
7.28	(185.0)	48	2.03	(51.6)
7.20	(183.0)	52	1.99	(50.5)
7.12	(181.0)	56	1.95	(49.5)
7.04	(179.0)	60	1.91	(48.5)
6.96	(177.0)	64	1.87	(47.5)
6.88	(175.0)	68	1.83	(46.5)
6.80	(172.5)	72	1.79	(45.5)
6.72	(170.5)	76	1.75	(44.5)
6.64	(168.5)	80	1.71	(43.4)
6.56	(166.5)	84	1.67	(42.4)
6.48	(164.5)	88	1.63	(41.4)
6.40	(162.5)	92	1.59	(40.4)
6.32	(160.5)	96	1.55	(39.4)
6.24	(158.5)	100	1.51	(38.4)
6.16	(156.5)	104	1.47	(37.3)
6.08	(154.5)	108	1.43	(36.3)
6.00	(152.5)	112	1.39	(35.3)
5.92	(150.5)	116	1.35	(34.3)
5.84	(148.5)	120	1.31	(33.3)



## D6H, D6R, D6T, 527 - 8.00 in. (203.2 mm)

### Carrier Rollers <sup>(1)</sup> Former - Bolt-On End Cover type

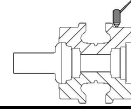
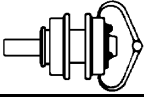

Caliper			Ultrasonic		
Inches	(mm)	% Worn	Inches	(mm)	
7.38	(187.5)	0	1.86	(47.2)	
7.30	(185.5)	8	1.82	(46.2)	
7.22	(183.5)	16	1.78	(45.2)	
7.14	(181.5)	24	1.74	(44.2)	
7.06	(179.5)	32	1.70	(43.2)	
6.98	(177.5)	40	1.66	(42.2)	
6.90	(175.5)	48	1.62	(41.1)	
6.82	(173.0)	56	1.58	(40.1)	
6.74	(171.0)	64	1.54	(39.1)	
6.66	(169.0)	68	1.50	(38.1)	
6.58	(167.0)	72	1.46	(37.1)	
6.50	(165.0)	76	1.42	(36.1)	
6.42	(163.0)	80	1.38	(35.1)	
6.34	(161.0)	84	1.34	(34.0)	
6.26	(159.0)	88	1.30	(33.0)	
6.18	(157.0)	92	1.26	(32.0)	
6.10	(155.0)	96	1.22	(31.0)	
6.02	(153.0)	100	1.18	(30.0)	
5.94	(151.0)	104	1.14	(29.0)	
5.86	(149.0)	108	1.10	(27.9)	
5.78	(147.0)	112	1.06	(26.9)	
5.70	(145.0)	116	1.02	(25.9)	
5.62	142.5	120	0.98	(24.9)	

# D6H, D6R, D6T, 527 - 8.00 in. (203.2 mm)

## Carrier Rollers <sup>(1)</sup> Use with 8E-2355 & 56 Sealed & Lubricated Track

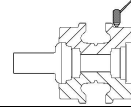
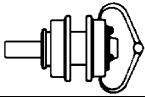

Caliper			Ultrasonic		
Inches	(mm)	% Worn	Inches	(mm)	
7.38	(187.5)	0	1.86	(47.2)	
7.34	(186.5)	5	1.84	(46.7)	
7.30	(185.5)	10	1.82	(46.2)	
7.26	(184.5)	15	1.80	(45.7)	
7.22	(183.5)	20	1.78	(45.2)	
7.18	(182.5)	25	1.76	(44.7)	
7.14	(181.5)	30	1.74	(44.2)	
7.10	(180.5)	35	1.72	(43.7)	
7.06	(179.5)	40	1.70	(43.2)	
7.02	(178.5)	45	1.68	(42.7)	
6.98	(177.5)	50	1.66	(42.2)	
6.94	(176.5)	55	1.64	(41.7)	
6.90	(175.5)	60	1.62	(41.1)	
6.86	(174.0)	65	1.60	(40.6)	
6.82	(173.0)	70	1.58	(40.1)	
6.78	(172.0)	75	1.56	(39.6)	
6.74	(171.0)	79	1.54	(39.1)	
6.70	(170.0)	82	1.52	(38.6)	
6.66	(169.0)	85	1.50	(38.1)	
6.62	(168.0)	88	1.48	(37.6)	
6.58	(167.0)	91	1.46	(37.1)	
6.54	(166.0)	94	1.44	(36.6)	
6.50	(165.0)	97	1.42	(36.1)	
6.46	(164.0)	100	1.40	(35.6)	
6.42	(163.0)	103	1.38	(35.1)	
6.38	(162.0)	106	1.36	(34.5)	
6.34	(161.0)	109	1.34	(34.0)	
6.30	(160.0)	112	1.32	(33.5)	
6.26	(159.0)	115	1.30	(33.0)	
6.22	(158.0)	118	1.28	(32.5)	
6.18	(157.0)	121	1.26	(32.0)	

1 Wear Chart: 4702

# D6H, D6R, D6T - 8.00 in. (203.2 mm)

## Track Rollers <sup>(1)</sup> SystemOne Track

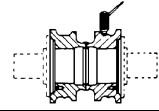
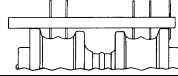

Caliper		% Worn	Depth Gauge		Ultrasonic	
Inches	(mm)		Inches	(mm)	Inches	(mm)
8.26	(210.0)	0	0.82	(21.0)	1.88	(47.8)
8.18	(208.0)	6	0.86	(22.0)	1.84	(46.7)
8.10	(205.5)	12	0.90	(23.0)	1.80	(45.7)
8.02	(203.5)	18	0.94	(24.0)	1.76	(44.7)
7.94	(201.5)	24	0.98	(25.0)	1.72	(43.7)
7.86	(199.5)	30	1.02	(26.0)	1.68	(42.7)
7.78	(197.5)	36	1.06	(27.0)	1.64	(41.7)
7.70	(195.5)	42	1.10	(28.0)	1.60	(40.6)
7.62	(193.5)	48	1.14	(29.0)	1.56	(39.6)
7.54	(191.5)	54	1.18	(30.0)	1.52	(38.6)
7.46	(189.5)	60	1.22	(31.0)	1.48	(37.6)
7.38	(187.5)	64	1.26	(32.0)	1.44	(36.6)
7.30	(185.5)	68	1.30	(33.0)	1.40	(35.6)
7.22	(183.5)	72	1.34	(34.0)	1.36	(34.5)
7.14	(181.5)	76	1.38	(35.0)	1.32	(33.5)
7.06	(179.5)	80	1.42	(36.0)	1.28	(32.5)
6.98	(177.5)	84	1.46	(37.0)	1.24	(31.5)
6.90	(175.5)	88	1.50	(38.0)	1.20	(30.5)
6.82	(173.0)	92	1.54	(39.0)	1.16	(29.5)
6.74	(171.0)	96	1.58	(40.0)	1.12	(28.4)
6.66	(169.0)	100	1.62	(41.0)	1.08	(27.4)
6.58	(167.0)	104	1.66	(42.0)	1.04	(26.4)
6.50	(165.0)	108	1.70	(43.0)	1.00	(25.4)
6.42	(163.0)	112	1.74	(44.0)	0.96	(24.4)
6.34	(161.0)	116	1.78	(45.0)	0.92	(23.4)
6.26	(159.0)	120	1.82	(46.0)	0.88	(22.4)

# D6H, D6R, D6T, 527 - 8.00 in. (203.2 mm)

## Track Rollers <sup>(1) (2)</sup>

Use with Heavy Duty, Rotating Bushing, or Enhanced SALT Track  
195-6515 & 16, 8E-7405 & 06, 378-8241 & 42, or 228-2735 & 36 Links

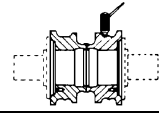
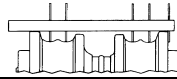
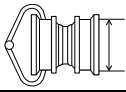

Caliper			Depth Gauge		Ultrasonic	
Inches	(mm)	% Worn	Inches	(mm)	Inches	(mm)
8.26	(210.0)	0	0.59	(15.0)	1.88	(47.8)
8.18	(208.0)	6	0.63	(16.0)	1.84	(46.7)
8.10	(205.5)	12	0.67	(17.0)	1.80	(45.7)
8.02	(203.5)	18	0.71	(18.0)	1.76	(44.7)
7.94	(201.5)	24	0.75	(19.0)	1.72	(43.7)
7.86	(199.5)	30	0.79	(20.0)	1.68	(42.7)
7.78	(197.5)	36	0.83	(21.0)	1.64	(41.7)
7.70	(195.5)	42	0.87	(22.0)	1.60	(40.6)
7.62	(193.5)	48	0.91	(23.0)	1.56	(39.6)
7.54	(191.5)	54	0.95	(24.0)	1.52	(38.6)
7.46	(189.5)	60	0.99	(25.0)	1.48	(37.6)
7.38	(187.5)	64	1.03	(26.0)	1.44	(36.6)
7.30	(185.5)	68	1.07	(27.0)	1.40	(35.6)
7.22	(183.5)	72	1.11	(28.0)	1.36	(34.5)
7.14	(181.5)	76	1.15	(29.0)	1.32	(33.5)
7.06	(179.5)	80	1.19	(30.0)	1.28	(32.5)
6.98	(177.5)	84	1.23	(31.0)	1.24	(31.5)
6.90	(175.5)	88	1.27	(32.5)	1.20	(30.5)
6.82	(173.0)	92	1.31	(33.5)	1.16	(29.5)
6.74	(171.0)	96	1.35	(34.5)	1.12	(28.4)
6.66	(169.0)	100	1.39	(35.5)	1.08	(27.4)
6.58	(167.0)	104	1.43	(36.5)	1.04	(26.4)
6.50	(165.0)	108	1.47	(37.5)	1.00	(25.4)
6.42	(163.0)	112	1.51	(38.5)	0.96	(24.4)
6.34	(161.0)	116	1.55	(39.5)	0.92	(23.4)
6.26	(159.0)	120	1.59	(40.5)	0.88	(22.4)

1 Flange diameter is 9.45 in. (240 mm)

2 Wear Chart: 5312

## D6H, D6R, D6T - 8.00 in. (203.2 mm)

### Track Rollers <sup>(1) (2)</sup> General Duty

**Use with Heavy Duty, Rotating Bushing, Enhanced SALT or General Duty Track  
195-6515 & 16, 8E-7405 & 06, 378-8241 & 42, 228-2735 & 36, or 418-2091 & 92 Links  
Not for use on 527**

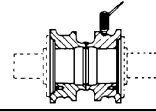
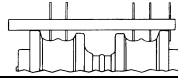

Caliper		% Worn	Depth Gauge		Ultrasonic	
Inches	(mm)		Inches	(mm)	Inches	(mm)
8.26	(210.0)	0	0.59	(15.0)	1.88	(47.8)
8.18	(208.0)	7	0.63	(16.0)	1.84	(46.7)
8.10	(205.5)	14	0.67	(17.0)	1.80	(45.7)
8.02	(203.5)	21	0.71	(18.0)	1.76	(44.7)
7.94	(201.5)	28	0.75	(19.0)	1.72	(43.7)
7.86	(199.5)	35	0.79	(20.0)	1.68	(42.7)
7.78	(197.5)	42	0.83	(21.0)	1.64	(41.7)
7.70	(195.5)	49	0.87	(22.0)	1.60	(40.6)
7.62	(193.5)	56	0.91	(23.0)	1.56	(39.6)
7.54	(191.5)	62	0.95	(24.0)	1.52	(38.6)
7.46	(189.5)	65	0.99	(25.0)	1.48	(37.6)
7.38	(187.5)	69	1.03	(26.0)	1.44	(36.6)
7.30	(185.5)	72	1.07	(27.0)	1.40	(35.6)
7.22	(183.5)	76	1.11	(28.0)	1.36	(34.5)
7.14	(181.5)	79	1.15	(29.0)	1.32	(33.5)
7.06	(179.5)	83	1.19	(30.0)	1.28	(32.5)
6.98	(177.5)	86	1.23	(31.0)	1.24	(31.5)
6.90	(175.5)	90	1.27	(32.5)	1.20	(30.5)
6.82	(173.0)	93	1.31	(33.5)	1.16	(29.5)
6.74	(171.0)	97	1.35	(34.5)	1.12	(28.4)
6.66	(169.0)	100	1.39	(35.5)	1.08	(27.4)
6.58	(167.0)	104	1.43	(36.5)	1.04	(26.4)
6.50	(165.0)	107	1.47	(37.5)	1.00	(25.4)
6.42	(163.0)	111	1.51	(38.5)	0.96	(24.4)
6.34	(161.0)	114	1.55	(39.5)	0.92	(23.4)
6.26	(159.0)	118	1.59	(40.5)	0.88	(22.4)
6.18	(157.0)	121	1.63	(41.5)	0.84	(21.3)

1 Flange diameter is 9.45 in. (240 mm)

2 Wear Chart: 5307

# D6H, D6R, D6T, 527 - 8.00 in. (203.2 mm)

**Tall Flange Track Rollers <sup>(1)</sup> <sup>(2)</sup>**  
**Tall Flange Double Flange Rollers**  
**Use with Heavy Duty and Rotating Bushing Track**  
**195-6515 & 16, 8E-7405 & 06, or 378-8241 & 42 Links**

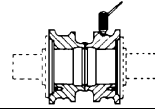
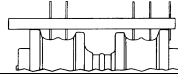
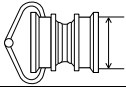

Caliper			Depth Gauge		Ultrasonic	
Inches	(mm)	% Worn	Inches	(mm)	Inches	(mm)
8.26	(210.0)	0	0.77	(19.5)	1.88	(47.8)
8.20	(208.5)	5	0.80	(20.5)	1.85	(47.0)
8.14	(207.0)	10	0.83	(21.0)	1.82	(46.2)
8.08	(205.0)	15	0.86	(22.0)	1.79	(45.5)
8.02	(203.5)	20	0.89	(22.5)	1.76	(44.7)
7.96	(202.0)	25	0.92	(23.5)	1.73	(43.9)
7.90	(200.5)	30	0.95	(24.0)	1.70	(43.2)
7.84	(199.0)	35	0.98	(25.0)	1.67	(42.4)
7.78	(197.5)	40	1.01	(25.5)	1.64	(41.7)
7.72	(196.0)	45	1.04	(26.5)	1.61	(40.9)
7.66	(194.5)	50	1.07	(27.0)	1.58	(40.1)
7.60	(193.0)	55	1.10	(28.0)	1.55	(39.4)
7.54	(191.5)	60	1.13	(28.5)	1.52	(38.6)
7.48	(190.0)	65	1.16	(29.5)	1.49	(37.8)
7.42	(188.5)	70	1.19	(30.0)	1.46	(37.1)
7.36	(187.0)	75	1.22	(31.0)	1.43	(36.3)
7.30	(185.5)	80	1.25	(32.0)	1.40	(35.6)
7.24	(184.0)	85	1.28	(32.5)	1.37	(34.8)
7.18	(182.5)	90	1.31	(33.5)	1.34	(34.0)
7.12	(181.0)	95	1.34	(34.0)	1.31	(33.3)
7.06	(179.5)	100	1.37	(35.0)	1.28	(32.5)
7.00	(178.0)	104	1.40	(35.5)	1.25	(31.8)
6.94	(176.5)	108	1.43	(36.5)	1.22	(31.0)
6.88	(175.0)	112	1.46	(37.0)	1.19	(30.2)
6.82	(173.0)	116	1.49	(38.0)	1.16	(29.5)
6.76	(171.5)	120	1.52	(38.5)	1.13	(28.7)

1 Flange diameter is 9.82 in. (249.5 mm)

2 Wear Chart: 6201

# D6H, D6R, D6T, 527 - 8.00 in. (203.2 mm)

## Sprockets <sup>(1)</sup> Not for use on 527 with Optional Large Diameter Bushing



### Tape Measure

Inches	(mm)	% Worn
8.85	(225.0)	0
8.80	(223.5)	7
8.75	(222.5)	14
8.70	(221.0)	21
8.65	(219.5)	28
8.60	(218.5)	35
8.55	(217.0)	42
8.50	(216.0)	49
8.45	(214.5)	55
8.40	(213.5)	60
8.35	(212.0)	65
8.30	(211.0)	70
8.25	(209.5)	75
8.20	(208.5)	80
8.15	(207.0)	85
8.10	(205.5)	90
8.05	(204.5)	95
8.00	(203.0)	100
7.95	(202.0)	105
7.90	(200.5)	110
7.85	(199.5)	115
7.80	(198.0)	120

#### NOTE

Note: Measure across 3 teeth

# D6H, D6R, D6T, 527 - 8.00 in. (203.2 mm)

## Sprockets <sup>(1)</sup> Use only with 527 Optional Large Diameter Bushing



### Tape Measure

Inches	(mm)	% Worn
8.55	(217.0)	0
8.50	(216.0)	10
8.45	(214.5)	20
8.40	(213.5)	30
8.35	(212.0)	40
8.30	(211.0)	50
8.25	(209.5)	60
8.20	(208.5)	68
8.15	(207.0)	76
8.10	(205.5)	84
8.05	(204.5)	92
8.00	(203.0)	100
7.95	(202.0)	108
7.90	(200.5)	116
7.85	(199.5)	124

#### NOTE

Note: Measure across 3 teeth





# D7H, D7R, 572R - 8.50 in. (215.9 mm)

**Track Links <sup>(1)</sup>  
Heavy Duty Track  
Rotating Bushing Track  
61-9239 & 40  
165-1758 & 59**

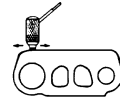
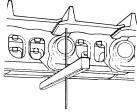

Depth Gauge			Ultrasonic	
Inches	(mm)	% Worn	Inches	(mm)
5.50	(139.5)	0	1.66	(42.2)
5.48	(139.0)	4	1.64	(41.7)
5.46	(138.5)	8	1.62	(41.1)
5.44	(138.0)	12	1.60	(40.6)
5.42	(137.5)	16	1.58	(40.1)
5.40	(137.0)	20	1.56	(39.6)
5.38	(136.5)	24	1.54	(39.1)
5.36	(136.0)	28	1.52	(38.6)
5.34	(135.5)	32	1.50	(38.1)
5.32	(135.0)	36	1.48	(37.6)
5.30	(134.5)	40	1.46	(37.1)
5.28	(134.0)	44	1.44	(36.6)
5.26	(133.5)	48	1.42	(36.1)
5.24	(133.0)	52	1.40	(35.6)
5.22	(132.5)	56	1.38	(35.1)
5.20	(132.0)	60	1.36	(34.5)
5.18	(131.5)	64	1.34	(34.0)
5.16	(131.0)	68	1.32	(33.5)
5.14	(130.5)	72	1.30	(33.0)
5.12	(130.0)	76	1.28	(32.5)
5.10	(129.5)	80	1.26	(32.0)
5.08	(129.0)	84	1.24	(31.5)
5.06	(128.5)	88	1.22	(31.0)
5.04	(128.0)	92	1.20	(30.5)
5.02	(127.5)	96	1.18	(30.0)
5.00	(127.0)	100	1.16	(29.5)
4.98	(126.5)	104	1.14	(29.0)
4.96	(126.0)	108	1.12	(28.4)
4.94	(125.5)	112	1.10	(27.9)
4.92	(125.0)	116	1.08	(27.4)
4.90	(124.5)	120	1.06	(26.9)

**Track Links <sup>(1)</sup>  
General Duty  
422-2659 & 60**

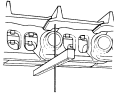

Depth Gauge			Ultrasonic	
In	(mm)	% Worn	In	(mm)
5.50	(139.5)	0	1.66	(42.2)
5.48	(139.0)	5	1.64	(41.7)
5.46	(138.5)	10	1.62	(41.1)
5.44	(138.0)	15	1.60	(40.6)
5.42	(137.5)	20	1.58	(40.1)
5.40	(137.0)	25	1.56	(39.6)
5.38	(136.5)	30	1.54	(39.1)
5.36	(136.0)	35	1.52	(38.6)
5.34	(135.5)	40	1.50	(38.1)
5.32	(135.0)	45	1.48	(37.6)
5.30	(134.5)	50	1.46	(37.1)
5.28	(134.0)	55	1.44	(36.6)
5.26	(133.5)	60	1.42	(36.1)
5.24	(133.0)	64	1.40	(35.6)
5.22	(132.5)	67	1.38	(35.1)
5.20	(132.0)	70	1.36	(34.5)
5.18	(131.5)	73	1.34	(34.0)
5.16	(131.0)	76	1.32	(33.5)
5.14	(130.5)	79	1.30	(33.0)
5.12	(130.0)	82	1.28	(32.5)
5.10	(129.5)	85	1.26	(32.0)
5.08	(129.0)	88	1.24	(31.5)
5.06	(128.5)	91	1.22	(31.0)
5.04	(128.0)	94	1.20	(30.5)
5.02	(127.5)	97	1.18	(30.0)
5.00	(127.0)	100	1.16	(29.5)
4.98	(126.5)	103	1.14	(29.0)
4.96	(126.0)	106	1.12	(28.4)
4.94	(125.5)	109	1.10	(27.9)
4.92	(125.0)	112	1.08	(27.4)
4.90	(124.5)	115	1.06	(26.9)
4.88	(124.0)	118	1.04	(26.4)
4.86	(123.5)	121	1.02	(25.9)

# D7H - 8.50 in. (215.9 mm)

Track Links <sup>(1)</sup>  
 Enhanced SALT Track  
 255-4789 & 90  
 289-3083 & 84

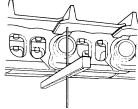

Depth Gauge			Ultrasonic	
Inches	(mm)	% Worn	Inches	(mm)
5.31	(135.0)	0	1.62	(41.1)
5.29	(134.5)	5	1.60	(40.6)
5.27	(134.0)	10	1.58	(40.1)
5.25	(133.5)	15	1.56	(39.6)
5.23	(133.0)	20	1.54	(39.1)
5.21	(132.5)	25	1.52	(38.6)
5.19	(132.0)	30	1.50	(38.1)
5.17	(131.5)	35	1.48	(37.6)
5.15	(131.0)	40	1.46	(37.1)
5.13	(130.5)	45	1.44	(36.6)
5.11	(130.0)	50	1.42	(36.1)
5.09	(129.5)	55	1.40	(35.6)
5.07	(129.0)	60	1.38	(35.1)
5.05	(128.5)	64	1.36	(34.5)
5.03	(128.0)	67	1.34	(34.0)
5.01	(127.5)	70	1.32	(33.5)
4.99	(126.5)	73	1.30	(33.0)
4.97	(126.0)	76	1.28	(32.5)
4.95	(125.5)	79	1.26	(32.0)
4.93	(125.0)	82	1.24	(31.5)
4.91	(124.5)	85	1.22	(31.0)
4.89	(124.0)	88	1.20	(30.5)
4.87	(123.5)	91	1.18	(30.0)
4.85	(123.0)	94	1.16	(29.5)
4.83	(122.5)	97	1.14	(29.0)
4.81	(122.0)	100	1.12	(28.4)
4.79	(121.5)	103	1.10	(27.9)
4.77	(121.0)	106	1.08	(27.4)
4.75	(120.5)	109	1.06	(26.9)
4.73	(120.0)	112	1.04	(26.4)
4.71	(119.5)	115	1.02	(25.9)
4.69	(119.0)	118	1.00	(25.4)
4.67	(118.5)	121	0.98	(24.9)

## D7H, D7R, 572R - 8.50 in. (215.9 mm)

### Track Links <sup>(1)</sup> Sealed & Lubricated Track 9G-2417 & 18

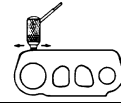
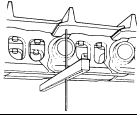

Depth Gauge			Ultrasonic	
Inches	(mm)	% Worn	Inches	(mm)
5.17	(131.5)	0	1.46	(37.1)
5.15	(131.0)	5	1.44	(36.6)
5.13	(130.5)	10	1.42	(36.1)
5.11	(130.0)	15	1.40	(35.6)
5.09	(129.5)	20	1.38	(35.1)
5.07	(129.0)	25	1.36	(34.5)
5.05	(128.5)	30	1.34	(34.0)
5.03	(128.0)	35	1.32	(33.5)
5.01	(127.5)	40	1.30	(33.0)
4.99	(126.5)	45	1.28	(32.5)
4.97	(126.0)	50	1.26	(32.0)
4.95	(125.5)	55	1.24	(31.5)
4.93	(125.0)	60	1.22	(31.0)
4.91	(124.5)	65	1.20	(30.5)
4.89	(124.0)	70	1.18	(30.0)
4.87	(123.5)	75	1.16	(29.5)
4.85	(123.0)	80	1.14	(29.0)
4.83	(122.5)	85	1.12	(28.4)
4.81	(122.0)	90	1.10	(27.9)
4.79	(121.5)	95	1.08	(27.4)
4.77	(121.0)	100	1.06	(26.9)
4.75	(120.5)	104	1.04	(26.4)
4.73	(120.0)	108	1.02	(25.9)
4.71	(119.5)	112	1.00	(25.4)
4.69	(119.0)	116	0.98	(24.9)
4.67	(118.5)	120	0.96	(24.4)

# D7H, D7R, 572R - 8.50 in. (215.9 mm)

## Bushings <sup>(1)</sup> Heavy Duty Track

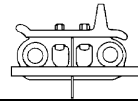
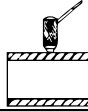

Caliper		Allowable Wear		Ultrasonic		Depth Gauge	
Inches	(mm)	Lesser % Worn	Greater % Worn	Inches	(mm)	Inches	(mm)
3.11	(79.0)	0	0	0.60	(15.2)	3.86	(98.0)
3.09	(78.5)	10	8	0.58	(14.7)	3.84	(97.5)
3.07	(78.0)	20	16	0.56	(14.2)	3.82	(97.0)
3.05	(77.5)	30	24	0.54	(13.7)	3.80	(96.5)
3.03	(77.0)	40	32	0.52	(13.2)	3.78	(96.0)
3.01	(76.5)	50	40	0.50	(12.7)	3.76	(95.5)
2.99	(75.9)	60	44	0.48	(12.2)	3.74	(95.0)
2.97	(75.4)	68	48	0.46	(11.7)	3.72	(94.5)
2.95	(74.9)	72	52	0.44	(11.2)	3.70	(94.0)
2.93	(74.4)	76	56	0.42	(10.7)	3.68	(93.5)
2.91	(73.9)	80	60	0.40	(10.2)	3.66	(93.0)
2.89	(73.4)	84	64	0.38	(9.7)	3.64	(92.5)
2.87	(72.9)	88	68	0.36	(9.1)	3.62	(91.9)
2.85	(72.4)	92	72	0.34	(8.6)	3.60	(91.4)
2.83	(71.9)	96	76	0.32	(8.1)	3.58	(90.9)
2.81	(71.4)	100	80	0.30	(7.6)	3.56	(90.4)
2.79	(70.9)	104	84	0.28	(7.1)	3.54	(89.9)
2.77	(70.4)	108	88	0.26	(6.6)	3.52	(89.4)
2.75	(69.9)	112	92	0.24	(6.1)	3.50	(88.9)
2.73	(69.3)	116	96	0.22	(5.6)	3.48	(88.4)
2.71	(68.8)	120	100	0.20	(5.1)	3.46	(87.9)
2.69	(68.3)		104	0.18	(4.6)	3.44	(87.4)
2.67	(67.8)		108	0.16	(4.1)	3.42	(86.9)
2.65	(67.3)		112	0.14	(3.6)	3.40	(86.4)
2.63	(66.8)		116	0.12	(3.0)	3.38	(85.9)
2.61	(66.3)		120	0.10	(2.5)	3.36	(85.3)

**Note: Do Not Use Depth Gauge Until Bushings Have Been "Turned."**

1 Wear Chart: 726

# D7H, D7R, 572R - 8.50 in. (215.9 mm)

## Bushings <sup>(1)</sup> Rotating Bushing Track

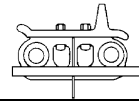
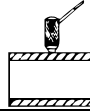

Caliper			Ultrasonic		Depth Gauge	
Inches	(mm)	% Worn	Inches	(mm)	Inches	(mm)
3.11	(79.0)	0	0.61	(15.5)	3.86	(98.0)
3.07	(78.0)	8	0.59	(15.0)	3.84	(97.5)
3.03	(77.0)	16	0.57	(14.5)	3.82	(97.0)
2.99	(75.9)	24	0.55	(14.0)	3.80	(96.5)
2.95	(74.9)	32	0.53	(13.5)	3.78	(96.0)
2.91	(73.9)	40	0.51	(13.0)	3.76	(95.5)
2.87	(72.9)	44	0.49	(12.4)	3.74	(95.0)
2.83	(71.9)	48	0.47	(11.9)	3.72	(94.5)
2.79	(70.9)	52	0.45	(11.4)	3.70	(94.0)
2.75	(69.9)	56	0.43	(10.9)	3.68	(93.5)
2.71	(68.8)	60	0.41	(10.4)	3.66	(93.0)
2.67	(67.8)	64	0.39	(9.9)	3.64	(92.5)
2.63	(66.8)	68	0.37	(9.4)	3.62	(91.9)
2.59	(65.8)	72	0.35	(8.9)	3.60	(91.4)
2.55	(64.8)	76	0.33	(8.4)	3.58	(90.9)
2.51	(63.8)	80	0.31	(7.9)	3.56	(90.4)
2.47	(62.7)	84	0.29	(7.4)	3.54	(89.9)
2.43	(61.7)	88	0.27	(6.9)	3.52	(89.4)
2.39	(60.7)	92	0.25	(6.3)	3.50	(88.9)
2.35	(59.7)	96	0.23	(5.8)	3.48	(88.4)
2.31	(58.7)	100	0.21	(5.3)	3.46	(87.9)
2.27	(57.7)	104	0.19	(4.8)	3.44	(87.4)
2.23	(56.6)	108	0.17	(4.3)	3.42	(86.9)
2.19	(55.6)	112	0.15	(3.8)	3.40	(86.4)
2.15	(54.6)	116	0.13	(3.3)	3.38	(85.9)
2.11	(53.6)	120	0.11	(2.8)	3.36	(85.3)

# D7H, D7R - 8.50 in. (215.9 mm)

## Bushings <sup>(1)</sup> General Duty Use with 422-2659 & 60 Links

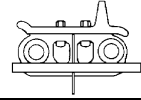
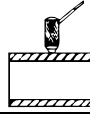

Caliper			Ultrasonic		Depth Gauge	
Inches	(mm)	% Worn	Inches	(mm)	Inches	(mm)
3.11	(79.0)	0	0.60	(15.2)	3.86	(98.0)
3.09	(78.5)	10	0.58	(14.7)	3.84	(97.5)
3.07	(78.0)	20	0.56	(14.2)	3.82	(97.0)
3.05	(77.5)	30	0.54	(13.7)	3.80	(96.5)
3.03	(77.0)	40	0.52	(13.2)	3.78	(96.0)
3.01	(76.5)	50	0.50	(12.7)	3.76	(95.5)
2.99	(75.9)	58	0.48	(12.2)	3.74	(95.0)
2.97	(75.4)	61	0.46	(11.7)	3.72	(94.5)
2.95	(74.9)	64	0.44	(11.2)	3.70	(94.0)
2.93	(74.4)	67	0.42	(10.7)	3.68	(93.5)
2.91	(73.9)	70	0.40	(10.2)	3.66	(93.0)
2.89	(73.4)	73	0.38	(9.7)	3.64	(92.5)
2.87	(72.9)	76	0.36	(9.1)	3.62	(91.9)
2.85	(72.4)	79	0.34	(8.6)	3.60	(91.4)
2.83	(71.9)	82	0.32	(8.1)	3.58	(90.9)
2.81	(71.4)	85	0.30	(7.6)	3.56	(90.4)
2.79	(70.9)	88	0.28	(7.1)	3.54	(89.9)
2.77	(70.4)	91	0.26	(6.6)	3.52	(89.4)
2.75	(69.9)	94	0.24	(6.1)	3.50	(88.9)
2.73	(69.3)	97	0.22	(5.6)	3.48	(88.4)
2.71	(68.8)	100	0.20	(5.1)	3.46	(87.9)
2.69	(68.3)	103	0.18	(4.6)	3.44	(87.4)
2.67	(67.8)	106	0.16	(4.1)	3.42	(86.9)
2.65	(67.3)	109	0.14	(3.6)	3.40	(86.4)
2.63	(66.8)	112	0.12	(3.0)	3.38	(85.9)
2.61	(66.3)	115	0.10	(2.5)	3.36	(85.3)
2.59	(65.8)	118	0.08	(2.0)	3.34	(84.8)
2.57	(65.3)	121	0.06	(1.5)	3.32	(84.3)

1 Wear Chart: 721



**Bushings<sup>(1)</sup>  
Enhanced SALT Track**

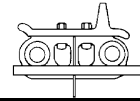
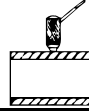

Caliper		Allowable Wear		Ultrasonic		Depth Gauge	
Inches	(mm)	Lesser % Worn	Greater % Worn	Inches	(mm)	Inches	(mm)
3.11	(79.0)	0	0	0.60	(15.2)	3.78	(96.0)
3.09	(78.5)	12	10	0.58	(14.7)	3.76	(95.5)
3.07	(78.0)	22	20	0.56	(14.2)	3.74	(95.0)
3.05	(77.5)	28	30	0.54	(13.7)	3.72	(94.5)
3.03	(77.0)	34	36	0.52	(13.2)	3.70	(94.0)
3.01	(76.5)	40	40	0.50	(12.7)	3.68	(93.5)
2.99	(75.9)	46	44	0.48	(12.2)	3.66	(93.0)
2.97	(75.4)	52	48	0.46	(11.7)	3.64	(92.5)
2.95	(74.9)	58	52	0.44	(11.2)	3.62	(91.9)
2.93	(74.4)	64	56	0.42	(10.7)	3.60	(91.4)
2.91	(73.9)	70	60	0.40	(10.2)	3.58	(90.9)
2.89	(73.4)	76	64	0.38	(9.7)	3.56	(90.4)
2.87	(72.9)	82	68	0.36	(9.1)	3.54	(89.9)
2.85	(72.4)	88	72	0.34	(8.6)	3.52	(89.4)
2.83	(71.9)	94	76	0.32	(8.1)	3.50	(88.9)
2.81	(71.4)	100	80	0.30	(7.6)	3.48	(88.4)
2.79	(70.9)	106	84	0.28	(7.1)	3.46	(87.9)
2.77	(70.4)	112	88	0.26	(6.6)	3.44	(87.4)
2.75	(69.9)	118	92	0.24	(6.1)	3.42	(86.9)
2.73	(69.3)	124	96	0.22	(5.6)	3.40	(86.4)
2.71	(68.8)		100	0.20	(5.1)	3.38	(85.9)
2.69	(68.3)		104	0.18	(4.6)	3.36	(85.3)
2.67	(67.8)		108	0.16	(4.1)	3.34	(84.8)
2.65	(67.3)		112	0.14	(3.6)	3.32	(84.3)
2.63	(66.8)		116	0.12	(3.0)	3.30	(83.8)
2.61	(66.3)		120	0.10	(2.5)	3.28	(83.3)

**Note: Do Not Use Depth Gauge Until Bushings Have Been "Turned."**

# D7H, D7R, 572R - 8.50 in. (215.9 mm)

## Bushings <sup>(1)</sup> Sealed & Lubricated Track

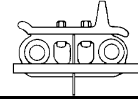
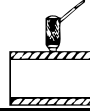

Caliper		Allowable Wear		Ultrasonic		Depth Gauge	
Inches	(mm)	Lesser % Worn	Greater % Worn	Inches	(mm)	Inches	(mm)
3.11	(79.0)	0	0	0.60	(15.2)	3.80	(96.5)
3.09	(78.5)	10	8	0.58	(14.7)	3.78	(96.0)
3.07	(78.0)	20	16	0.56	(14.2)	3.76	(95.5)
3.05	(77.5)	30	24	0.54	(13.7)	3.74	(95.0)
3.03	(77.0)	40	32	0.52	(13.2)	3.72	(94.5)
3.01	(76.5)	50	40	0.50	(12.7)	3.70	(94.0)
2.99	(75.9)	60	44	0.48	(12.2)	3.68	(93.5)
2.97	(75.4)	68	48	0.46	(11.7)	3.66	(93.0)
2.95	(74.9)	72	52	0.44	(11.2)	3.64	(92.5)
2.93	(74.4)	76	56	0.42	(10.7)	3.62	(91.9)
2.91	(73.9)	80	60	0.40	(10.2)	3.60	(91.4)
2.89	(73.4)	84	64	0.38	(9.7)	3.58	(90.9)
2.87	(72.9)	88	68	0.36	(9.1)	3.56	(90.4)
2.85	(72.4)	92	72	0.34	(8.6)	3.54	(89.9)
2.83	(71.9)	96	76	0.32	(8.1)	3.52	(89.4)
2.81	(71.4)	100	80	0.30	(7.6)	3.50	(88.9)
2.79	(70.9)	104	84	0.28	(7.1)	3.48	(88.4)
2.77	(70.4)	108	88	0.26	(6.6)	3.46	(87.9)
2.75	(69.9)	112	92	0.24	(6.1)	3.44	(87.4)
2.73	(69.3)	116	96	0.22	(5.6)	3.42	(86.9)
2.71	(68.8)	120	100	0.20	(5.1)	3.40	(86.4)
2.69	(68.3)		104	0.18	(4.6)	3.38	(85.9)
2.67	(67.8)		108	0.16	(4.1)	3.36	(85.3)
2.65	(67.3)		112	0.14	(3.6)	3.34	(84.8)
2.63	(66.8)		116	0.12	(3.0)	3.32	(84.3)
2.61	(66.3)		120	0.10	(2.5)	3.30	(83.8)

**Note: Do Not Use Depth Gauge Until Bushings Have Been "Turned."**

1 Wear Chart: 723

## D7H, D7R, 572R - 8.50 in. (215.9 mm)

### Track Shoes <sup>(1)</sup> Extreme Service

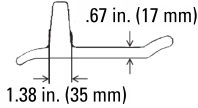
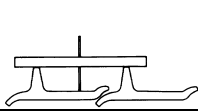

Depth Gauge		High Impact	Low/Moderate	Ultrasonic	
Inches	(mm)	% Worn	Impact % Worn	Inches	(mm)
3.20	(81.5)	0	0	3.90	(99.1)
3.10	(78.5)	6	5	3.80	(96.5)
3.00	(76.0)	12	10	3.70	(94.0)
2.90	(73.5)	18	15	3.60	(91.4)
2.80	(71.0)	24	20	3.50	(88.9)
2.70	(68.5)	30	25	3.40	(86.4)
2.60	(66.0)	36	30	3.30	(83.8)
2.50	(63.5)	42	35	3.20	(81.3)
2.40	(61.0)	48	40	3.10	(78.7)
2.30	(58.5)	54	45	3.00	(76.2)
2.20	(56.0)	60	50	2.90	(73.7)
2.10	(53.5)	66	55	2.80	(71.1)
2.00	(51.0)	72	60	2.70	(68.6)
1.90	(48.5)	78	64	2.60	(66.0)
1.80	(45.5)	84	68	2.50	(63.5)
1.70	(43.0)	90	72	2.40	(61.0)
1.60	(40.5)	95	76	2.30	(58.4)
1.50	(38.0)	100	80	2.20	(55.9)
1.40	(35.5)	105	84	2.10	(53.3)
1.30	(33.0)	110	88	2.00	(50.8)
1.20	(30.5)	115	92	1.90	(48.3)
1.10	(28.0)	120	96	1.80	(45.7)
1.00	(25.5)		100	1.70	(43.2)
0.90	(23.0)		104	1.60	(40.6)
0.80	(20.5)		108	1.50	(38.1)
0.70	(18.0)		112	1.40	(35.6)
0.60	(15.0)		116	1.30	(33.0)
0.50	(12.5)		120	1.20	(30.5)

# D7H, D7R, 572R - 8.50 in. (215.9 mm)

## Track Shoes <sup>(1)</sup> Moderate Service Genuine and General Duty

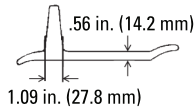
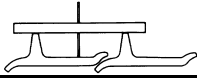

Depth Gauge		High Impact	Low/Moderate	Ultrasonic	
Inches	(mm)	% Worn	Impact % Worn	Inches	(mm)
2.90	(73.5)	0	0	3.45	(87.6)
2.80	(71.0)	8	6	3.35	(85.1)
2.70	(68.5)	16	12	3.25	(82.6)
2.60	(66.0)	23	18	3.15	(80.0)
2.50	(63.5)	30	24	3.05	(77.5)
2.40	(61.0)	37	30	2.95	(74.9)
2.30	(58.5)	44	35	2.85	(72.4)
2.20	(56.0)	51	40	2.75	(69.9)
2.10	(53.5)	58	45	2.65	(67.3)
2.00	(51.0)	65	50	2.55	(64.8)
1.90	(48.5)	72	55	2.45	(62.2)
1.80	(45.5)	79	60	2.35	(59.7)
1.70	(43.0)	86	65	2.25	(57.2)
1.60	(40.5)	93	70	2.15	(54.6)
1.50	(38.0)	100	75	2.05	(52.1)
1.40	(35.5)	107	80	1.95	(49.5)
1.30	(33.0)	114	85	1.85	(47.0)
1.20	(30.5)	121	90	1.75	(44.5)
1.10	(28.0)		95	1.65	(41.9)
1.00	(25.5)		100	1.55	(39.4)
0.90	(23.0)		105	1.45	(36.8)
0.80	(20.5)		110	1.35	(34.3)
0.70	(18.0)		115	1.25	(31.8)
0.60	(15.0)		120	1.15	(29.2)

# D7H, D7R, 572R - 8.50 in. (215.9 mm)

## Track Shoes <sup>(1)</sup> Double Grouser

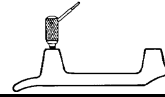
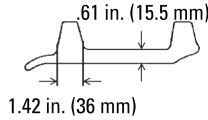
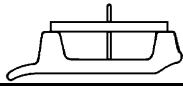

Depth Gauge		High Impact	Low/Moderate	Ultrasonic	
Inches	(mm)	% Worn	Impact % Worn	Inches	(mm)
1.95	(49.5)	0	0	2.55	(64.8)
1.90	(48.5)	5	4	2.50	(63.5)
1.85	(47.0)	10	8	2.45	(62.2)
1.80	(45.5)	15	12	2.40	(61.0)
1.75	(44.5)	20	16	2.35	(59.7)
1.70	(43.0)	24	20	2.30	(58.4)
1.65	(42.0)	28	24	2.25	(57.2)
1.60	(40.5)	32	28	2.20	(55.9)
1.55	(39.5)	36	32	2.15	(54.6)
1.50	(38.0)	40	36	2.10	(53.3)
1.45	(37.0)	44	40	2.05	(52.1)
1.40	(35.5)	48	44	2.00	(50.8)
1.35	(34.5)	52	48	1.95	(49.5)
1.30	(33.0)	56	52	1.90	(48.3)
1.25	(32.0)	60	55	1.85	(47.0)
1.20	(30.5)	64	58	1.80	(45.7)
1.15	(29.0)	68	61	1.75	(44.5)
1.10	(28.0)	72	64	1.70	(43.2)
1.05	(26.5)	76	67	1.65	(41.9)
1.00	(25.5)	80	70	1.60	(40.6)
0.95	(24.0)	84	73	1.55	(39.4)
0.90	(23.0)	88	76	1.50	(38.1)
0.85	(21.5)	92	79	1.45	(36.8)
0.80	(20.5)	96	82	1.40	(35.6)
0.75	(19.0)	100	85	1.35	(34.3)
0.70	(18.0)	104	88	1.30	(33.0)
0.65	(16.5)	108	91	1.25	(31.8)
0.60	(15.0)	112	94	1.20	(30.5)
0.55	(14.0)	116	97	1.15	(29.2)
0.50	(12.5)	120	100	1.10	(27.9)
0.45	(11.5)		103	1.05	(26.7)
0.40	(10.0)		106	1.00	(25.4)
0.35	(9.0)		109	0.95	(24.1)
0.30	(7.5)		112	0.90	(22.9)
0.25	(6.5)		115	0.85	(21.6)
0.20	(5.0)		118	0.80	(20.3)
0.15	(4.0)		121	0.75	(19.1)

# D7H, D7R, 572R - 8.50 in. (215.9 mm)

Track Shoes <sup>(1)</sup>  
Self Cleaning



Depth Gauge

Inches	(mm)	% Worn
4.36	(110.5)	0
4.34	(110.0)	4
4.32	(109.5)	8
4.30	(109.0)	12
4.28	(108.5)	16
4.26	(108.0)	20
4.24	(107.5)	24
4.22	(107.0)	28
4.20	(106.5)	32
4.18	(106.0)	36
4.16	(105.5)	40
4.14	(105.0)	44
4.12	(104.5)	48
4.10	(104.0)	52
4.08	(103.5)	55
4.06	(103.0)	58
4.04	(102.5)	61
4.02	(102.0)	64
4.00	(101.5)	67
3.98	(101.0)	70
3.96	(100.5)	73
3.94	(100.0)	76
3.92	(99.5)	79
3.90	(99.0)	82
3.88	(98.5)	85
3.86	(98.0)	88
3.84	(97.5)	91
3.82	(97.0)	94
3.80	(96.5)	97
3.78	(96.0)	100
3.76	(95.5)	103
3.74	(95.0)	106
3.72	(94.5)	109
3.70	(94.0)	112
3.68	(93.5)	115
3.66	(93.0)	118
3.64	(92.5)	121

1 Wear Chart: 1920

## D7H, D7R, 572R - 8.50 in. (215.9 mm)

### Track Shoes <sup>(1)</sup> Chopper

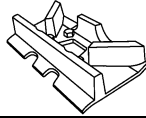

Depth Gauge			Ultrasonic	
Inches	(mm)	% Worn	Inches	(mm)
3.15	(80.0)	0	3.75	(95.3)
3.05	(77.5)	5	3.65	(92.7)
2.95	(75.0)	10	3.55	(90.2)
2.85	(72.5)	15	3.45	(87.6)
2.75	(70.0)	20	3.35	(85.1)
2.65	(67.5)	24	3.25	(82.6)
2.55	(65.0)	28	3.15	(80.0)
2.45	(62.0)	32	3.05	(77.5)
2.35	(59.5)	36	2.95	(74.9)
2.25	(57.0)	40	2.85	(72.4)
2.15	(54.5)	44	2.75	(69.9)
2.05	(52.0)	48	2.65	(67.3)
1.95	(49.5)	52	2.55	(64.8)
1.85	(47.0)	56	2.45	(62.2)
1.75	(44.5)	60	2.35	(59.7)
1.65	(42.0)	64	2.25	(57.2)
1.55	(39.5)	68	2.15	(54.6)
1.45	(37.0)	72	2.05	(52.1)
1.35	(34.5)	76	1.95	(49.5)
1.25	(31.5)	80	1.85	(47.0)
1.15	(29.0)	84	1.75	(44.5)
1.05	(26.5)	88	1.65	(41.9)
0.95	(24.0)	92	1.55	(39.4)
0.85	(21.5)	96	1.45	(36.8)
0.75	(19.0)	100	1.35	(34.3)
0.65	(16.5)	104	1.25	(31.7)
0.55	(14.0)	108	1.15	(29.2)
0.45	(11.5)	112	1.0	(26.7)
0.35	(9.0)	116	0.95	(24.1)
0.25	(6.5)	120	0.85	(21.6)

# D7H, D7R, 572R - 8.50 in. (215.9 mm)

## Idlers <sup>(1)</sup> <sup>(2)</sup> <sup>(3)</sup> Center Tread Idler

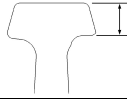

### Ultrasonic, Depth Gauge or Caliper

Inches	(mm)	% Worn
1.66	(42.0)	0
1.64	(41.5)	4
1.62	(41.0)	8
1.60	(40.5)	12
1.58	(40.0)	16
1.56	(39.5)	19
1.54	(39.0)	22
1.52	(38.5)	25
1.50	(38.0)	28
1.48	(37.5)	31
1.46	(37.0)	34
1.44	(36.5)	37
1.42	(36.0)	40
1.40	(35.5)	43
1.38	(35.0)	46
1.36	(34.5)	49
1.34	(34.0)	52
1.32	(33.5)	55
1.30	(33.0)	58
1.28	(32.5)	61
1.26	(32.0)	64
1.24	(31.5)	67
1.22	(31.0)	70
1.20	(30.5)	73
1.18	(30.0)	76
1.16	(29.5)	79
1.14	(29.0)	82
1.12	(28.5)	85
1.10	(28.0)	88
1.08	(27.5)	91
1.06	(27.0)	94
1.04	(26.5)	97
1.02	(26.0)	100
1.00	(25.5)	103
0.98	(25.0)	106
0.96	(24.5)	109
0.94	(24.0)	112
0.92	(23.5)	115
0.90	(23.0)	118
0.88	(22.5)	121

1 New tread diameter is 25.20 in. (640 mm)

2 For measuring instructions, reference General Information topic *Idler Wear – Center Tread Idlers* on, page 51.

3 Wear Chart: 4120



## D7H, D7R, 572R - 8.50 in. (215.9 mm)

### Idlers <sup>(1)</sup> <sup>(2)</sup> <sup>(3)</sup> Genuine and General Duty

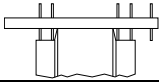

**Depth Gauge**

Inches	(mm)	% Worn
0.78	(20.0)	0
0.82	(21.0)	12
0.86	(22.0)	24
0.90	(23.0)	36
0.94	(24.0)	48
0.98	(25.0)	60
1.02	(26.0)	68
1.06	(27.0)	72
1.10	(28.0)	76
1.14	(29.0)	80
1.18	(30.0)	84
1.22	(31.0)	88
1.26	(32.0)	92
1.30	(33.0)	96
1.34	(34.0)	100
1.38	(35.0)	104
1.42	(36.0)	108
1.46	(37.0)	112
1.50	(38.0)	116
1.54	(39.0)	120



**Ultrasonic**

**Center Flange Wear**

Inches	(mm)	Inches	(mm)
0.48	(12.2)	0.00	(0.0)
0.44	(11.2)	0.04	(1.0)
0.40	(10.2)	0.08	(2.0)
0.36	(9.1)	0.12	(3.0)
0.32	(8.1)	0.16	(4.0)
0.28	(7.1)	0.20	(5.0)
0.24	(6.1)	0.24	(6.0)
0.20	(5.1)	0.28	(7.0)
0.16	(4.1)	0.32	(8.0)
0.12	(3.0)	0.36	(9.0)
0.08	(2.0)	0.40	(10.0)
0.04	(1.0)	0.44	(11.0)

#### **NOTE**

Ultrasonic measurement is to determine flange wear only. Use ultrasonic only on fabricated idlers.

- 1 Flange Width is 4.02 in. (102 mm)
- 2 New tread diameter is 23.03 in. (585 mm), 23.82 in. (605 mm), or 24.72 in. (628 mm).
- 3 Wear Chart: 4427

# D7H, D7R, 572R - 8.50 in. (215.9 mm)

## Carrier Rollers <sup>(1)</sup> Permanently Sealed

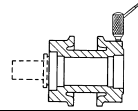
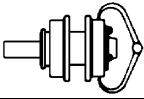

Caliper			Ultrasonic	
Inches	(mm)	% Worn	Inches	(mm)
7.50	(190.5)	0	2.13	(54.1)
7.42	(188.5)	8	2.09	(53.1)
7.34	(186.5)	16	2.05	(52.1)
7.26	(184.5)	24	2.01	(51.1)
7.18	(182.5)	32	1.97	(50.0)
7.10	(180.5)	40	1.93	(49.0)
7.02	(178.5)	48	1.89	(48.0)
6.94	(176.5)	52	1.85	(47.0)
6.86	(174.0)	56	1.81	(46.0)
6.78	(172.0)	60	1.77	(45.0)
6.70	(170.0)	64	1.73	(43.9)
6.62	(168.0)	68	1.69	(42.9)
6.54	(166.0)	72	1.65	(41.9)
6.46	(164.0)	76	1.61	(40.9)
6.38	(162.0)	80	1.57	(39.9)
6.30	(160.0)	84	1.53	(38.9)
6.22	(158.0)	88	1.49	(37.8)
6.14	(156.0)	92	1.45	(36.8)
6.06	(154.0)	96	1.41	(35.8)
5.98	(152.0)	100	1.37	(34.8)
5.90	(150.0)	104	1.33	(33.8)
5.82	(148.0)	108	1.29	(32.8)
5.74	(146.0)	112	1.25	(31.8)
5.66	(144.0)	116	1.21	(30.7)
5.58	(141.5)	120	1.17	(29.7)

1 Wear Chart: 4726

## D7H, D7R, 572R - 8.50 in. (215.9 mm)

### Carrier Rollers <sup>(1)</sup> Bolt-On End Cover

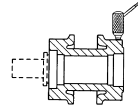
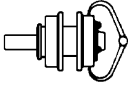

Caliper			Ultrasonic		
Inches	(mm)	% Worn	Inches	(mm)	
7.50	(190.5)	0	1.92	(48.8)	
7.42	(188.5)	8	1.88	(47.8)	
7.34	(186.5)	16	1.84	(46.7)	
7.26	(184.5)	24	1.80	(45.7)	
7.18	(182.5)	32	1.76	(44.7)	
7.10	(180.5)	40	1.72	(43.7)	
7.02	(178.5)	48	1.68	(42.7)	
6.94	(176.5)	52	1.64	(41.7)	
6.86	(174.0)	56	1.60	(40.6)	
6.78	(172.0)	60	1.56	(39.6)	
6.70	(170.0)	64	1.52	(38.6)	
6.62	(168.0)	68	1.48	(37.6)	
6.54	(166.0)	72	1.44	(36.6)	
6.46	(164.0)	76	1.40	(35.6)	
6.38	(162.0)	80	1.36	(34.5)	
6.30	(160.0)	84	1.32	(33.5)	
6.22	(158.0)	88	1.28	(32.5)	
6.14	(156.0)	92	1.24	(31.5)	
6.06	(154.0)	96	1.20	(30.5)	
5.98	(152.0)	100	1.16	(29.5)	
5.90	(150.0)	104	1.12	(28.4)	
5.82	(148.0)	108	1.08	(27.4)	
5.74	(146.0)	112	1.04	(26.4)	
5.66	(144.0)	116	1.00	(25.4)	
5.58	(141.5)	120	0.96	(24.4)	

# D7H, D7R, 572R - 8.50 in. (215.9 mm)

## Carrier Rollers <sup>(1)</sup> Use with Sealed and Lubricated Track

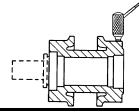
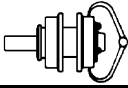

Caliper			Ultrasonic		
Inches	(mm)	% Worn	Inches	(mm)	
7.50	(190.5)	0	1.92	(48.8)	
7.46	(189.5)	6	1.90	(48.3)	
7.42	(188.5)	12	1.88	(47.8)	
7.38	(187.5)	18	1.86	(47.2)	
7.34	(186.5)	24	1.84	(46.7)	
7.30	(185.5)	30	1.82	(46.2)	
7.26	(184.5)	36	1.80	(45.7)	
7.22	(183.5)	42	1.78	(45.2)	
7.18	(182.5)	48	1.76	(44.7)	
7.14	(181.5)	54	1.74	(44.2)	
7.10	(180.5)	60	1.72	(43.7)	
7.06	(179.5)	66	1.70	(43.2)	
7.02	(178.5)	72	1.68	(42.7)	
6.98	(177.5)	76	1.66	(42.2)	
6.94	(176.5)	80	1.64	(41.7)	
6.90	(175.5)	84	1.62	(41.1)	
6.86	(174.0)	88	1.60	(40.6)	
6.82	(173.0)	92	1.58	(40.1)	
6.78	(172.0)	96	1.56	(39.6)	
6.74	(171.0)	100	1.54	(39.1)	
6.70	(170.0)	104	1.52	(38.6)	
6.66	(169.0)	108	1.50	(38.1)	
6.62	(168.0)	112	1.48	(37.6)	
6.58	(167.0)	116	1.46	(37.1)	
6.54	(166.0)	120	1.44	(36.6)	

1 Wear Chart: 4720

## D7H, D7R, 572R - 8.50 in. (215.9 mm)

**Track Rollers with End Collars and Standardized Rollers <sup>(1) (2)</sup>**  
**Use with Heavy Duty, Rotating Bushing, or Enhanced SALT Track**  
**6I-9239 & 40 or 255-4791 & 92 Links**

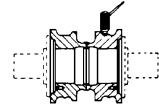
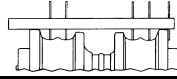
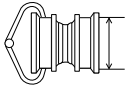

Caliper			Depth Gauge		Ultrasonic	
Inches	(mm)	% Worn	Inches	(mm)	Inches	(mm)
8.76	(222.5)	0	0.63	(16.0)	2.06	(52.3)
8.68	(220.5)	6	0.67	(17.0)	2.02	(51.3)
8.60	(218.5)	12	0.71	(18.0)	1.98	(50.3)
8.52	(216.5)	18	0.75	(19.0)	1.94	(49.3)
8.44	(214.5)	24	0.79	(20.0)	1.90	(48.3)
8.36	(212.5)	30	0.83	(21.0)	1.86	(47.2)
8.28	(210.5)	36	0.87	(22.0)	1.82	(46.2)
8.20	(208.5)	42	0.91	(23.0)	1.78	(45.2)
8.12	(206.0)	48	0.95	(24.0)	1.74	(44.2)
8.04	(204.0)	54	0.99	(25.0)	1.70	(43.2)
7.96	(202.0)	60	1.03	(26.0)	1.66	(42.2)
7.88	(200.0)	64	1.07	(27.0)	1.62	(41.1)
7.80	(198.0)	68	1.11	(28.0)	1.58	(40.1)
7.72	(196.0)	72	1.15	(29.0)	1.54	(39.1)
7.64	(194.0)	76	1.19	(30.0)	1.50	(38.1)
7.56	(192.0)	80	1.23	(31.0)	1.46	(37.1)
7.48	(190.0)	84	1.27	(32.5)	1.42	(36.1)
7.40	(188.0)	88	1.31	(33.5)	1.38	(35.1)
7.32	(186.0)	92	1.35	(34.5)	1.34	(34.0)
7.24	(184.0)	96	1.39	(35.5)	1.30	(33.0)
7.16	(182.0)	100	1.43	(36.5)	1.26	(32.0)
7.08	(180.0)	104	1.47	(37.5)	1.22	(31.0)
7.00	(178.0)	108	1.51	(38.5)	1.18	(30.0)
6.92	(176.0)	112	1.55	(39.5)	1.14	(29.0)
6.84	(173.5)	116	1.59	(40.5)	1.10	(27.9)
6.76	(171.5)	120	1.63	(41.5)	1.06	(26.9)

1 Flange diameter is 10.04 in. (255 mm)  
 2 Wear Chart: 5327

# D7H, D7R - 8.50 in. (215.9 mm)

## Track Rollers with End Caps <sup>(1) (2)</sup> General Duty

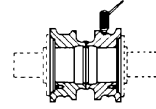
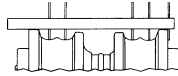
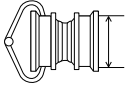

Caliper		% Worn	Depth Gauge		Ultrasonic	
Inches	(mm)		Inches	(mm)	Inches	(mm)
8.76	(222.5)	0	0.63	(16.0)	2.06	(52.3)
8.68	(220.5)	7	0.67	(17.0)	2.02	(51.3)
8.60	(218.5)	14	0.71	(18.0)	1.98	(50.3)
8.52	(216.5)	21	0.75	(19.0)	1.94	(49.3)
8.44	(214.5)	28	0.79	(20.0)	1.90	(48.3)
8.36	(212.5)	35	0.83	(21.0)	1.86	(47.2)
8.28	(210.5)	42	0.87	(22.0)	1.82	(46.2)
8.20	(208.5)	49	0.91	(23.0)	1.78	(45.2)
8.12	(206.0)	56	0.95	(24.0)	1.74	(44.2)
8.04	(204.0)	62	0.99	(25.0)	1.70	(43.2)
7.96	(202.0)	65	1.03	(26.0)	1.66	(42.2)
7.88	(200.0)	69	1.07	(27.0)	1.62	(41.1)
7.80	(198.0)	72	1.11	(28.0)	1.58	(40.1)
7.72	(196.0)	76	1.15	(29.0)	1.54	(39.1)
7.64	(194.0)	79	1.19	(30.0)	1.50	(38.1)
7.56	(192.0)	83	1.23	(31.0)	1.46	(37.1)
7.48	(190.0)	86	1.27	(32.5)	1.42	(36.1)
7.40	(188.0)	90	1.31	(33.5)	1.38	(35.1)
7.32	(186.0)	93	1.35	(34.5)	1.34	(34.0)
7.24	(184.0)	97	1.39	(35.5)	1.30	(33.0)
7.16	(182.0)	100	1.43	(36.5)	1.26	(32.0)
7.08	(180.0)	104	1.47	(37.5)	1.22	(31.0)
7.00	(178.0)	107	1.51	(38.5)	1.18	(30.0)
6.92	(176.0)	111	1.55	(39.5)	1.14	(29.0)
6.84	(173.5)	114	1.59	(40.5)	1.10	(27.9)
6.76	(171.5)	118	1.63	(41.5)	1.06	(26.9)
6.68	(169.5)	121	1.67	(42.5)	1.02	(25.9)

1 Flange diameter is 10.02 in. (255 mm)

2 Wear Chart: 5339

## D7H, D7R, 572R - 8.50 in. (215.9 mm)

**Tall Flange Track Rollers with End Collars and Standardized Rollers <sup>(1) (2)</sup>**

**Tall Flange Double Flange Rollers**

**Use with Heavy Duty, Rotating Bushing, or Enhanced SALT Track  
6I-9239 & 40 or 255-4791 & 92 Links**

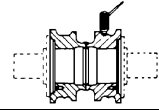
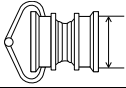

Caliper			Depth Gauge		Ultrasonic	
Inches	(mm)	% Worn	Inches	(mm)	Inches	(mm)
8.76	(222.5)	0	0.82	(21.0)	2.06	(52.3)
8.68	(220.5)	8	0.86	(22.0)	2.02	(51.3)
8.60	(218.5)	16	0.90	(23.0)	1.98	(50.3)
8.52	(216.5)	24	0.94	(24.0)	1.94	(49.3)
8.44	(214.5)	32	0.98	(25.0)	1.90	(48.3)
8.36	(212.5)	40	1.02	(26.0)	1.86	(47.2)
8.28	(210.5)	46	1.06	(27.0)	1.82	(46.2)
8.20	(208.5)	52	1.10	(28.0)	1.78	(45.2)
8.12	(206.0)	58	1.14	(29.0)	1.74	(44.2)
8.04	(204.0)	64	1.18	(30.0)	1.70	(43.2)
7.96	(202.0)	70	1.22	(31.0)	1.66	(42.2)
7.88	(200.0)	76	1.26	(32.0)	1.62	(41.1)
7.80	(198.0)	82	1.30	(33.0)	1.58	(40.1)
7.72	(196.0)	88	1.34	(34.0)	1.54	(39.1)
7.64	(194.0)	94	1.38	(35.0)	1.50	(38.1)
7.56	(192.0)	100	1.42	(36.0)	1.46	(37.1)
7.48	(190.0)	106	1.46	(37.0)	1.42	(36.1)
7.40	(188.0)	112	1.50	(38.0)	1.38	(35.1)
7.32	(186.0)	118	1.54	(39.0)	1.34	(34.0)
7.24	(184.0)	124	1.58	(40.0)	1.30	(33.0)

1 Flange diameter is 10.43 in. (265 mm)

2 Wear Chart: 5328

# D7H, D7R, 572R - 8.50 in. (215.9 mm)

**Track Rollers with Retainers<sup>(1) (2)</sup>**  
**Use with Heavy Duty, Rotating Bushing, or Enhanced SALT Track**  
**6I-9239 & 40 or 255-4791 & 92 Links**

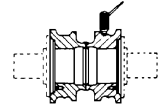
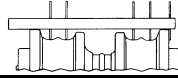
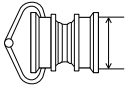

Caliper			Depth Gauge		Ultrasonic	
Inches	(mm)	% Worn	Inches	(mm)	Inches	(mm)
8.74	(222.0)	0	0.65	(16.5)	1.99	(50.5)
8.66	(220.0)	6	0.69	(17.5)	1.95	(49.5)
8.58	(218.0)	12	0.73	(18.5)	1.91	(48.5)
8.50	(216.0)	18	0.77	(19.5)	1.87	(47.5)
8.42	(214.0)	24	0.81	(20.5)	1.83	(46.5)
8.34	(212.0)	30	0.85	(21.5)	1.79	(45.5)
8.26	(210.0)	36	0.89	(22.5)	1.75	(44.5)
8.18	(208.0)	42	0.93	(23.5)	1.71	(43.4)
8.10	(205.5)	48	0.97	(24.5)	1.67	(42.4)
8.02	(203.5)	54	1.01	(25.5)	1.63	(41.4)
7.94	(201.5)	60	1.05	(26.5)	1.59	(40.4)
7.86	(199.5)	64	1.09	(27.5)	1.55	(39.4)
7.78	(197.5)	68	1.13	(28.5)	1.51	(38.4)
7.70	(195.5)	72	1.17	(29.5)	1.47	(37.3)
7.62	(193.5)	76	1.21	(30.5)	1.43	(36.3)
7.54	(191.5)	80	1.25	(32.0)	1.39	(35.3)
7.46	(189.5)	84	1.29	(33.0)	1.35	(34.3)
7.38	(187.5)	88	1.33	(34.0)	1.31	(33.3)
7.30	(185.5)	92	1.37	(35.0)	1.27	(32.3)
7.22	(183.5)	96	1.41	(36.0)	1.23	(31.2)
7.14	(181.5)	100	1.45	(37.0)	1.19	(30.2)
7.06	(179.5)	104	1.49	(38.0)	1.15	(29.2)
6.98	(177.5)	108	1.53	(39.0)	1.11	(28.2)
6.90	(175.5)	112	1.57	(40.0)	1.07	(27.2)
6.82	(173.0)	116	1.61	(41.0)	1.03	(26.2)
6.74	(171.0)	120	1.65	(42.0)	0.99	(25.1)

1 Flange diameter is 10.04 in. (255 mm)

2 Wear Chart: 5334



# D7H, D7R, 572R - 8.50 in. (215.9 mm)

## Sprockets <sup>(1)</sup>



Tape Measure		
Inches	(mm)	% Worn
9.40	(239.0)	0
9.35	(237.5)	7
9.30	(236.0)	14
9.25	(235.0)	21
9.20	(233.5)	28
9.15	(232.5)	35
9.10	(231.0)	40
9.05	(230.0)	45
9.00	(228.5)	50
8.95	(227.5)	55
8.90	(226.0)	60
8.85	(225.0)	65
8.80	(223.5)	70
8.75	(222.5)	75
8.70	(221.0)	80
8.65	(219.5)	85
8.60	(218.5)	90
8.55	(217.0)	95
8.50	(216.0)	100
8.45	(214.5)	105
8.40	(213.5)	110
8.35	(212.0)	115
8.30	(211.0)	120

**NOTE**

Measure across 3 teeth



**Track Links <sup>(1)</sup>  
SystemOne Track  
304-5680**

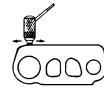
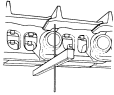

Depth Gauge		Allowable Wear Greater % <sup>(2)</sup> Worn	Ultrasonic	
Inches	(mm)		Inches	(mm)
5.98	(152.0)	0	1.67	(42.4)
5.96	(151.5)	4	1.65	(41.9)
5.94	(151.0)	8	1.63	(41.4)
5.92	(150.5)	12	1.61	(40.9)
5.90	(150.0)	16	1.59	(40.4)
5.88	(149.5)	20	1.57	(39.9)
5.86	(149.0)	24	1.55	(39.4)
5.84	(148.5)	28	1.53	(38.9)
5.82	(148.0)	32	1.51	(38.4)
5.80	(147.5)	36	1.49	(37.8)
5.78	(147.0)	40	1.47	(37.3)
5.76	(146.5)	44	1.45	(36.8)
5.74	(146.0)	48	1.43	(36.3)
5.72	(145.5)	52	1.41	(35.8)
5.70	(145.0)	55	1.39	(35.3)
5.68	(144.5)	57	1.37	(34.8)
5.66	(144.0)	60	1.35	(34.3)
5.64	(143.5)	62	1.33	(33.8)
5.62	(142.5)	65	1.31	(33.3)
5.60	(142.0)	67	1.29	(32.8)
5.58	(141.5)	70	1.27	(32.3)
5.56	(141.0)	72	1.25	(31.8)
5.54	(140.5)	75	1.23	(31.2)
5.52	(140.0)	77	1.21	(30.7)
5.50	(139.5)	80	1.19	(30.2)
5.48	(139.0)	82	1.17	(29.7)
5.46	(138.5)	85	1.15	(29.2)
5.44	(138.0)	87	1.13	(28.7)
5.42	(137.5)	90	1.11	(28.2)
5.40	(137.0)	92	1.09	(27.7)
5.38	(136.5)	95	1.07	(27.2)
5.36	(136.0)	97	1.05	(26.7)
5.34	(135.5)	100	1.03	(26.2)
5.32	(135.0)	102	1.01	(25.7)
5.30	(134.5)	105	0.99	(25.1)
5.28	(134.0)	107	0.97	(24.6)
5.26	(133.5)	110	0.95	(24.1)
5.24	(133.0)	112	0.93	(23.6)
5.22	(132.5)	115	0.91	(23.1)
5.20	(132.0)	117	0.89	(22.6)
5.18	(131.5)	120	0.87	(22.1)

1 Wear Chart: 131

2 If 304-5680 link cracking has been experienced, please use the Lesser Allowable Wear chart located on, page 274 at the end of the Elevated Sprocket Machine Section. Also see, page 88 for further definition of Link Allowable Wear.

**D8L, D8N, D8R, D8T, 578, 583R, 583T, 587R, 587T, PL83, PL87 - 8.50 in. (215.9 mm)**

**Track Links<sup>(1)</sup>  
8E-4505 & 06  
8E-4513 & 14**



Depth Gauge		Allowable Wear Greater % <sup>(2)</sup> Worn	Ultrasonic	
Inches	(mm)		Inches	(mm)
5.90	(150.0)	0	1.88	(47.8)
5.88	(149.5)	4	1.86	(47.2)
5.86	(149.0)	8	1.84	(46.7)
5.84	(148.5)	12	1.82	(46.2)
5.82	(148.0)	16	1.80	(45.7)
5.80	(147.5)	20	1.78	(45.2)
5.78	(147.0)	24	1.76	(44.7)
5.76	(146.5)	28	1.74	(44.2)
5.74	(146.0)	32	1.72	(43.7)
5.72	(145.5)	36	1.70	(43.2)
5.70	(145.0)	40	1.68	(42.7)
5.68	(144.5)	44	1.66	(42.2)
5.66	(144.0)	48	1.64	(41.7)
5.64	(143.5)	52	1.62	(41.1)
5.62	(142.5)	55	1.60	(40.6)
5.60	(142.0)	57	1.58	(40.1)
5.58	(141.5)	60	1.56	(39.6)
5.56	(141.0)	62	1.54	(39.1)
5.54	(140.5)	65	1.52	(38.6)
5.52	(140.0)	67	1.50	(38.1)
5.50	(139.5)	70	1.48	(37.6)
5.48	(139.0)	72	1.46	(37.1)
5.46	(138.5)	75	1.44	(36.6)
5.44	(138.0)	77	1.42	(36.1)
5.42	(137.5)	80	1.40	(35.6)
5.40	(137.0)	82	1.38	(35.1)
5.38	(136.5)	85	1.36	(34.5)
5.36	(136.0)	87	1.34	(34.0)
5.34	(135.5)	90	1.32	(33.5)
5.32	(135.0)	92	1.30	(33.0)
5.30	(134.5)	95	1.28	(32.5)
5.28	(134.0)	97	1.26	(32.0)
5.26	(133.5)	100	1.24	(31.5)
5.24	(133.0)	102	1.22	(31.0)
5.22	(132.5)	105	1.20	(30.5)
5.20	(132.0)	107	1.18	(30.0)
5.18	(131.5)	110	1.16	(29.5)
5.16	(131.0)	112	1.14	(29.0)
5.14	(130.5)	115	1.12	(28.4)
5.12	(130.0)	117	1.10	(27.9)
5.10	(129.5)	120	1.08	(27.4)

1 Wear Chart: 125

2 If 8E-4505 & 06, 8E-4513 & 14 link cracking has been experienced, please use the Lesser Allowable Wear chart located on, page 275 at the end of the Elevated Sprocket Machine Section. Also see, page 88 for further definition of Link Allowable Wear.

# D8N, D8R, D8T - 8.50 in. (215.9 mm)

## Track Links <sup>(1)</sup> General Duty 391-3943 & 44

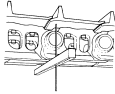

Depth Gauge		Worn	Ultrasonic	
Inches	(mm)		Inches	(mm)
5.90	(150.0)	0	1.88	(47.8)
5.88	(149.5)	5	1.86	(47.2)
5.86	(149.0)	10	1.84	(46.7)
5.84	(148.5)	15	1.82	(46.2)
5.82	(148.0)	20	1.80	(45.7)
5.80	(147.5)	25	1.78	(45.2)
5.78	(147.0)	30	1.76	(44.7)
5.76	(146.5)	35	1.74	(44.2)
5.74	(146.0)	40	1.72	(43.7)
5.72	(145.5)	45	1.70	(43.2)
5.70	(145.0)	50	1.68	(42.7)
5.68	(144.5)	55	1.66	(42.2)
5.66	(144.0)	60	1.64	(41.7)
5.64	(143.5)	62	1.62	(41.1)
5.62	(142.5)	64	1.60	(40.6)
5.60	(142.0)	66	1.58	(40.1)
5.58	(141.5)	68	1.56	(39.6)
5.56	(141.0)	70	1.54	(39.1)
5.54	(140.5)	72	1.52	(38.6)
5.52	(140.0)	74	1.50	(38.1)
5.50	(139.5)	76	1.48	(37.6)
5.48	(139.0)	78	1.46	(37.1)
5.46	(138.5)	80	1.44	(36.6)
5.44	(138.0)	82	1.42	(36.1)
5.42	(137.5)	84	1.40	(35.6)
5.40	(137.0)	86	1.38	(35.1)
5.38	(136.5)	88	1.36	(34.5)
5.36	(136.0)	90	1.34	(34.0)
5.32	(135.0)	94	1.30	(33.0)
5.28	(134.0)	98	1.26	(32.0)
5.26	(133.5)	100	1.24	(31.5)
5.22	(132.5)	104	1.20	(30.5)
5.18	(131.5)	108	1.16	(29.5)
5.14	(130.5)	112	1.12	(28.4)
5.10	(129.5)	116	1.08	(27.4)
5.06	(128.5)	120	1.04	(26.4)

# D8N, D8R, D8T - 8.58 in. (218 mm)

## Bushings <sup>(1)</sup> SystemOne Track

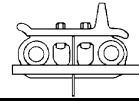
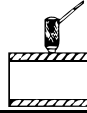

Caliper		% Worn	Ultrasonic		Depth Gauge	
Inches	(mm)		Inches	(mm)	Inches	(mm)
3.29	(83.6)	0	0.62	(15.7)	4.28	(108.7)
3.27	(83.1)	5	0.61	(15.5)	4.27	(108.5)
3.25	(82.6)	10	0.60	(15.2)	4.26	(108.2)
3.23	(82.0)	15	0.59	(15.0)	4.25	(108.0)
3.21	(81.5)	20	0.58	(14.7)	4.24	(107.7)
3.19	(81.0)	25	0.57	(14.5)	4.23	(107.4)
3.17	(80.5)	30	0.56	(14.2)	4.22	(107.2)
3.15	(80.0)	35	0.55	(14.0)	4.21	(106.9)
3.13	(79.5)	40	0.54	(13.7)	4.20	(106.7)
3.11	(79.0)	45	0.53	(13.5)	4.19	(106.4)
3.09	(78.5)	50	0.52	(13.2)	4.18	(106.2)
3.07	(78.0)	55	0.51	(13.0)	4.17	(105.9)
3.05	(77.5)	60	0.50	(12.7)	4.16	(105.7)
3.03	(77.0)	65	0.49	(12.4)	4.15	(105.4)
3.01	(76.5)	70	0.48	(12.2)	4.14	(105.2)
2.99	(75.9)	72	0.47	(11.9)	4.13	(104.9)
2.97	(75.4)	74	0.46	(11.7)	4.12	(104.6)
2.95	(74.9)	76	0.45	(11.4)	4.11	(104.4)
2.93	(74.4)	78	0.44	(11.2)	4.10	(104.1)
2.91	(73.9)	80	0.43	(10.9)	4.09	(103.9)
2.89	(73.4)	82	0.42	(10.7)	4.08	(103.6)
2.87	(72.9)	84	0.41	(10.4)	4.07	(103.4)
2.85	(72.4)	86	0.40	(10.2)	4.06	(103.1)
2.83	(71.9)	88	0.39	(9.9)	4.05	(102.9)
2.81	(71.4)	90	0.38	(9.7)	4.04	(102.6)
2.79	(70.9)	92	0.37	(9.4)	4.03	(102.4)
2.77	(70.4)	94	0.36	(9.1)	4.02	(102.1)
2.75	(69.9)	96	0.35	(8.9)	4.01	(101.9)
2.73	(69.3)	98	0.34	(8.6)	4.00	(101.6)
2.71	(68.8)	100	0.33	(8.4)	3.99	(101.3)
2.69	(68.3)	102	0.32	(8.1)	3.98	(101.1)
2.67	(67.8)	104	0.31	(7.9)	3.97	(100.8)
2.65	(67.3)	106	0.30	(7.6)	3.96	(100.6)
2.63	(66.8)	108	0.29	(7.4)	3.95	(100.3)
2.61	(66.3)	110	0.28	(7.1)	3.94	(100.1)
2.59	(65.8)	112	0.27	(6.9)	3.93	(99.8)
2.57	(65.3)	114	0.26	(6.6)	3.92	(99.6)
2.55	(64.8)	116	0.25	(6.3)	3.91	(99.3)
2.53	(64.3)	118	0.24	(6.1)	3.90	(99.1)
2.51	(63.8)	120	0.23	(5.8)	3.89	(98.8)

1 Wear Chart: 733/734

**D8L, D8N, D8R, D8T, 578, 583R, 583T, 587R, 587T, PL83, PL87 - 8.50 in. (215.9 mm)**

**Bushings<sup>(1)</sup>  
Sealed & Lubricated Track  
Genuine and General Duty**

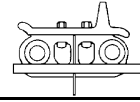
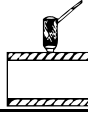
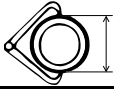

Caliper		Allowable Wear		Ultrasonic		Depth Gauge	
Inches	(mm)	Lesser % Worn	Greater % Worn	Inches	(mm)	Inches	(mm)
3.11	(79.0)	0	0	0.60	(15.2)	4.11	(104.4)
3.09	(78.5)	10	8	0.58	(14.7)	4.09	(103.9)
3.07	(78.0)	20	16	0.56	(14.2)	4.07	(103.4)
3.05	(77.5)	30	24	0.54	(13.7)	4.05	(102.9)
3.03	(77.0)	40	32	0.52	(13.2)	4.03	(102.4)
3.01	(76.5)	50	40	0.50	(12.7)	4.01	(101.9)
2.99	(75.9)	60	44	0.48	(12.2)	3.99	(101.3)
2.97	(75.4)	68	48	0.46	(11.7)	3.97	(100.8)
2.95	(74.9)	72	52	0.44	(11.2)	3.95	(100.3)
2.93	(74.4)	76	56	0.42	(10.7)	3.93	(99.8)
2.91	(73.9)	80	60	0.40	(10.2)	3.91	(99.3)
2.89	(73.4)	84	64	0.38	(9.7)	3.89	(98.8)
2.87	(72.9)	88	68	0.36	(9.1)	3.87	(98.3)
2.85	(72.4)	92	72	0.34	(8.6)	3.85	(97.8)
2.83	(71.9)	96	76	0.32	(8.1)	3.83	(97.3)
2.81	(71.4)	100	80	0.30	(7.6)	3.81	(96.8)
2.79	(70.9)	104	84	0.28	(7.1)	3.79	(96.3)
2.77	(70.4)	108	88	0.26	(6.6)	3.77	(95.8)
2.75	(69.9)	112	92	0.24	(6.1)	3.75	(95.3)
2.73	(69.3)	116	96	0.22	(5.6)	3.73	(94.7)
2.71	(68.8)	120	100	0.20	(5.1)	3.71	(94.2)
2.69	(68.3)		104	0.18	(4.6)	3.69	(93.7)
2.67	(67.8)		108	0.16	(4.1)	3.67	(93.2)
2.65	(67.3)		112	0.14	(3.6)	3.65	(92.7)
2.63	(66.8)		116	0.12	(3.0)	3.63	(92.2)
2.61	(66.3)		120	0.10	(2.5)	3.61	(91.7)

**Note: Do Not Use Depth Gauge Until Bushings Have Been "Turned."**

**D8L, D8N, D8R, D8T, 578, 583R, 583T, 587R, 587T, PL83, PL87 - 8.50 in. (215.9 mm)**

**Track Shoes <sup>(1)</sup>  
Super Extreme Service**

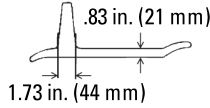
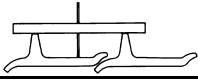

Depth Gauge		High Impact	Low/Moderate	Ultrasonic	
Inches	(mm)	% Worn	Impact % Worn	Inches	(mm)
3.70	(94.0)	0	0	4.50	(114.3)
3.60	(91.5)	5	4	4.40	(111.8)
3.50	(89.0)	10	8	4.30	(109.2)
3.40	(86.5)	15	12	4.20	(106.7)
3.30	(84.0)	20	16	4.10	(104.1)
3.20	(81.5)	25	20	4.00	(101.6)
3.10	(78.5)	30	24	3.90	(99.1)
3.00	(76.0)	35	28	3.80	(96.5)
2.90	(73.5)	40	32	3.70	(94.0)
2.80	(71.0)	45	36	3.60	(91.4)
2.70	(68.5)	50	40	3.50	(88.9)
2.60	(66.0)	55	44	3.40	(86.4)
2.50	(63.5)	60	48	3.30	(83.8)
2.40	(61.0)	64	52	3.20	(81.3)
2.30	(58.5)	68	56	3.10	(78.7)
2.20	(56.0)	72	60	3.00	(76.2)
2.10	(53.5)	76	64	2.90	(73.7)
2.00	(51.0)	80	68	2.80	(71.1)
1.90	(48.5)	84	72	2.70	(68.6)
1.80	(45.5)	88	76	2.60	(66.0)
1.70	(43.0)	92	79	2.50	(63.5)
1.60	(40.5)	96	82	2.40	(61.0)
1.50	(38.0)	100	85	2.30	(58.4)
1.40	(35.5)	104	88	2.20	(55.9)
1.30	(33.0)	108	91	2.10	(53.3)
1.20	(30.5)	112	94	2.00	(50.8)
1.10	(28.0)	116	97	1.90	(48.3)
1.00	(25.5)	120	100	1.80	(45.7)
0.90	(23.0)		103	1.70	(43.2)
0.80	(20.5)		106	1.60	(40.6)
0.70	(18.0)		109	1.50	(38.1)
0.60	(15.0)		112	1.40	(35.6)
0.50	(12.5)		115	1.30	(33.0)
0.40	(10.0)		118	1.20	(30.5)
0.30	(7.5)		121	1.10	(27.9)



**D8L, D8N, D8R, D8T, 578, 583R, 583T, 587R, 587T, PL83, PL87 - 8.50 in. (215.9 mm)**

**Track Shoes <sup>(1)</sup>  
Extreme Service  
Genuine and General Duty**

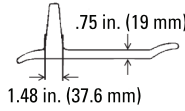
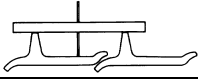

Depth Gauge		High Impact	Low/Moderate	Ultrasonic	
Inches	(mm)	% Worn	Impact % Worn	Inches	(mm)
3.30	(84.0)	0	0	4.05	(102.9)
3.20	(81.5)	6	5	3.95	(100.3)
3.10	(78.5)	12	10	3.85	(97.8)
3.00	(76.0)	18	15	3.75	(95.3)
2.90	(73.5)	24	20	3.65	(92.7)
2.80	(71.0)	30	25	3.55	(90.2)
2.70	(68.5)	36	30	3.45	(87.6)
2.60	(66.0)	42	35	3.35	(85.1)
2.50	(63.5)	48	40	3.25	(82.6)
2.40	(61.0)	54	44	3.15	(80.0)
2.30	(58.5)	60	48	3.05	(77.5)
2.20	(56.0)	65	52	2.95	(74.9)
2.10	(53.5)	70	56	2.85	(72.4)
2.00	(51.0)	75	60	2.75	(69.9)
1.90	(48.5)	80	64	2.65	(67.3)
1.80	(45.5)	85	68	2.55	(64.8)
1.70	(43.0)	90	72	2.45	(62.2)
1.60	(40.5)	95	76	2.35	(59.7)
1.50	(38.0)	100	80	2.25	(57.1)
1.40	(35.5)	105	84	2.15	(54.6)
1.30	(33.0)	110	88	2.05	(52.1)
1.20	(30.5)	115	92	1.95	(49.5)
1.10	(28.0)	120	96	1.85	(47.0)
1.00	(25.5)		100	1.75	(44.4)
0.90	(23.0)		104	1.65	(41.9)
0.80	(20.5)		108	1.55	(39.4)
0.70	(18.0)		112	1.45	(36.8)
0.60	(15.0)		116	1.35	(34.3)
0.50	(12.5)		120	1.25	(31.7)

# D8L, D8N, D8R, D8T, 578, 583R, 583T, 587R, 587T - 8.50 in. (215.9 mm)

## Track Shoes <sup>(1)</sup> Moderate Service

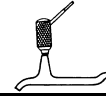
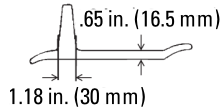
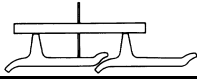

Depth Gauge		High Impact % Worn	Low/Moderate Impact % Worn	Ultrasonic	
Inches	(mm)			Inches	(mm)
3.10	(78.5)	0	0	3.75	(95.3)
3.00	(76.0)	7	5	3.65	(92.7)
2.90	(73.5)	14	10	3.55	(90.2)
2.80	(71.0)	21	15	3.45	(87.6)
2.70	(68.5)	28	20	3.35	(85.1)
2.60	(66.0)	34	25	3.25	(82.6)
2.50	(63.5)	40	30	3.15	(80.0)
2.40	(61.0)	46	35	3.05	(77.5)
2.30	(58.5)	52	40	2.95	(74.9)
2.20	(56.0)	58	45	2.85	(72.4)
2.10	(53.5)	64	50	2.75	(69.9)
2.00	(51.0)	70	55	2.65	(67.3)
1.90	(48.5)	76	60	2.55	(64.8)
1.80	(45.5)	82	65	2.45	(62.2)
1.70	(43.0)	88	70	2.35	(59.7)
1.60	(40.5)	94	75	2.25	(57.2)
1.50	(38.0)	100	80	2.15	(54.6)
1.40	(35.5)	106	84	2.05	(52.1)
1.30	(33.0)	112	88	1.95	(49.5)
1.20	(30.5)	118	92	1.85	(47.0)
1.10	(28.0)	124	96	1.75	(44.5)
1.00	(25.5)		100	1.65	(41.9)
0.90	(23.0)		104	1.55	(39.4)
0.80	(20.5)		108	1.45	(36.8)
0.70	(18.0)		112	1.35	(34.3)
0.60	(15.0)		116	1.25	(31.7)
0.50	(12.5)		120	1.15	(29.2)

## D8L, D8N, D8R, D8T - 8.50 in. (215.9 mm)

### Track Shoes <sup>(1)</sup> Chopper

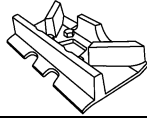

Depth Gauge			Ultrasonic	
Inches	(mm)	% Worn	Inches	(mm)
3.30	(84.0)	0	3.85	(97.8)
3.20	(81.5)	5	3.75	(95.3)
3.10	(78.5)	10	3.65	(92.7)
3.00	(76.0)	15	3.55	(90.2)
2.90	(73.5)	20	3.45	(87.6)
2.80	(71.0)	25	3.35	(85.1)
2.70	(68.5)	30	3.25	(82.6)
2.60	(66.0)	35	3.15	(80.0)
2.50	(63.5)	40	3.05	(77.5)
2.40	(61.0)	44	2.95	(74.9)
2.30	(58.5)	48	2.85	(72.4)
2.20	(56.0)	52	2.75	(69.9)
2.10	(53.5)	56	2.65	(67.3)
2.00	(51.0)	60	2.55	(64.8)
1.90	(48.5)	64	2.45	(62.2)
1.80	(45.5)	68	2.35	(59.7)
1.70	(43.0)	72	2.25	(57.2)
1.60	(40.5)	76	2.15	(54.6)
1.50	(38.0)	80	2.05	(52.1)
1.40	(35.5)	84	1.95	(49.5)
1.30	(33.0)	88	1.85	(47.0)
1.20	(30.5)	92	1.75	(44.5)
1.10	(28.0)	96	1.65	(41.9)
1.00	(25.5)	100	1.55	(39.4)
0.90	(23.0)	104	1.45	(36.8)
0.80	(20.5)	108	1.35	(34.3)
0.70	(18.0)	112	1.25	(31.7)
0.60	(15.0)	116	1.15	(29.2)
0.50	(12.5)	120	1.05	(26.7)

## D8N, D8R, D8T - 8.58 in. (218 mm)

Idlers (1) (2) (3) (4)  
Relieved Tread Idlers

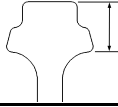

Depth Gauge or Caliper

Inches	(mm)	% Worn
2.47	(62.5)	0
2.43	(61.5)	6
2.39	(60.5)	12
2.35	(59.5)	18
2.31	(58.5)	24
2.27	(57.5)	30
2.23	(56.5)	36
2.19	(55.5)	42
2.15	(54.5)	48
2.11	(53.5)	54
2.07	(52.5)	60
2.03	(51.5)	64
1.99	(50.5)	68
1.95	(49.5)	72
1.91	(48.5)	76
1.87	(47.5)	80
1.83	(46.5)	84
1.79	(45.5)	88
1.75	(44.5)	92
1.71	(43.5)	96
1.67	(42.5)	100
1.63	(41.5)	104
1.59	(40.5)	108
1.55	(39.5)	112
1.51	(38.5)	116
1.47	(37.5)	120

- 1 New tread diameter, front large diameter idler is 30.94 in. (786 mm)
- 2 New tread diameter, rear small diameter idler is 28.35 in. (720 mm)
- 3 For measuring instructions, reference General Information topic *Idler Wear – Center Tread Idlers and Relieved Center Tread Idlers* on, [page 51](#).
- 4 Wear Chart: 4431

**D8L, D8N, D8R, D8T, 578, 583R, 583T, 587R, 587T, PL83, PL87 - 8.50 in. (215.9 mm)**

**Idlers <sup>(1) (2) (3) (4)</sup>  
Genuine and General Duty**

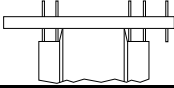

Depth Gauge		
Inches	(mm)	% Worn
0.78	(20.0)	0
0.82	(21.0)	8
0.86	(22.0)	16
0.90	(23.0)	24
0.94	(24.0)	32
0.98	(25.0)	40
1.02	(26.0)	48
1.06	(27.0)	56
1.10	(28.0)	64
1.14	(29.0)	72
1.18	(30.0)	76
1.22	(31.0)	80
1.26	(32.0)	84
1.30	(33.0)	88
1.34	(34.0)	92
1.38	(35.0)	96
1.42	(36.0)	100
1.46	(37.0)	104
1.50	(38.0)	108
1.54	(39.0)	112
1.58	(40.0)	116
1.62	(41.0)	120

Ultrasonic		Center Flange Wear	
Inches	(mm)	Inches	(mm)
0.56	(14.2)	0.00	(0.0)
0.52	(13.2)	0.04	(1.0)
0.48	(12.2)	0.08	(2.0)
0.44	(11.2)	0.12	(3.0)
0.40	(10.2)	0.16	(4.0)
0.36	(9.1)	0.20	(5.0)
0.32	(8.1)	0.24	(6.0)
0.28	(7.1)	0.28	(7.0)
0.24	(6.1)	0.32	(8.0)
0.20	(5.1)	0.36	(9.0)
0.16	(4.1)	0.40	(10.0)
0.12	(3.0)	0.44	(11.0)
0.08	(2.0)	0.48	(12.0)
0.04	(1.0)	0.52	(13.0)
0.00	(0.0)	0.56	(14.0)

**NOTE**

Ultrasonic measurement is to determine flange wear only. Use ultrasonic only on fabricated idlers.

- 1 Flange Width is 3.81 in. (97 mm)
- 2 New tread diameter, front large diameter idler is 27.48 in. (698 mm)
- 3 New tread diameter, rear small diameter idler is 24.41 in. (620 mm)
- 4 Wear Chart: 4424

# D8L, D8N, D8R, 578, 583R - 8.50 in. (215.9 mm)

## Carrier Rollers <sup>(1)</sup>

For D8T, 583T, 587R, 587T, PL83, and PL87 use Single Flange Track Roller wear chart

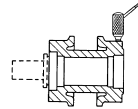
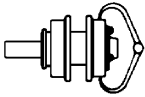

Caliper			Ultrasonic	
Inches	(mm)	% Worn	Inches	(mm)
7.50	(190.5)	0	1.92	(48.8)
7.42	(188.5)	8	1.88	(47.8)
7.34	(186.5)	16	1.84	(46.7)
7.26	(184.5)	24	1.80	(45.7)
7.18	(182.5)	32	1.76	(44.7)
7.10	(180.5)	40	1.72	(43.7)
7.02	(178.5)	48	1.68	(42.7)
6.94	(176.5)	52	1.64	(41.7)
6.86	(174.0)	56	1.60	(40.6)
6.78	(172.0)	60	1.56	(39.6)
6.70	(170.0)	64	1.52	(38.6)
6.62	(168.0)	68	1.48	(37.6)
6.54	(166.0)	72	1.44	(36.6)
6.46	(164.0)	76	1.40	(35.6)
6.38	(162.0)	80	1.36	(34.5)
6.30	(160.0)	84	1.32	(33.5)
6.22	(158.0)	88	1.28	(32.5)
6.14	(156.0)	92	1.24	(31.5)
6.06	(154.0)	96	1.20	(30.5)
5.98	(152.0)	100	1.16	(29.5)
5.90	(150.0)	104	1.12	(28.4)
5.82	(148.0)	108	1.08	(27.4)
5.74	(146.0)	112	1.04	(26.4)
5.66	(144.0)	116	1.00	(25.4)
5.58	(141.5)	120	0.96	(24.4)

1 Wear Chart: 4725

**D8L, D8N, D8R, D8T, 578, 583R, 583T, 587R, 587T, PL83, PL87 - 8.50 in. (215.9 mm)**

**Track Rollers <sup>(1) (2)</sup>  
Single Flange**

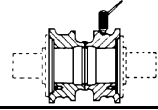

Caliper		% Worn	Depth Gauge		Ultrasonic	
Inches	(mm)		Inches	(mm)	Inches	(mm)
9.72	247.0	0	0.55	14.0	2.48	63.0
9.62	244.5	5	0.60	15.0	2.43	61.7
9.52	242.0	10	0.65	16.5	2.38	60.5
9.42	239.5	15	0.70	18.0	2.33	59.2
9.32	236.5	20	0.75	19.0	2.28	57.9
9.22	234.0	25	0.80	20.5	2.23	56.6
9.12	231.5	30	0.85	21.5	2.18	55.4
9.02	229.0	35	0.90	23.0	2.13	54.1
8.92	226.5	40	0.95	24.0	2.08	52.8
8.82	224.0	45	1.00	25.5	2.03	51.6
8.72	221.5	50	1.05	26.5	1.98	50.3
8.62	219.0	55	1.10	28.0	1.93	49.0
8.52	216.5	60	1.15	29.0	1.88	47.8
8.42	214.0	64	1.20	30.5	1.83	46.5
8.32	211.5	68	1.25	32.0	1.78	45.2
8.22	209.0	72	1.30	33.0	1.73	43.9
8.12	206.0	76	1.35	34.5	1.68	42.7
8.02	203.5	80	1.40	35.5	1.63	41.4
7.92	201.0	84	1.45	37.0	1.58	40.1
7.82	198.5	88	1.50	38.0	1.53	38.9
7.72	196.0	92	1.55	39.5	1.48	37.6
7.62	193.5	96	1.60	40.5	1.43	36.3
7.52	191.0	100	1.65	42.0	1.38	35.1
7.42	188.5	104	1.70	43.0	1.33	33.8
7.32	186.0	108	1.75	44.5	1.28	32.5
7.22	183.5	112	1.80	45.5	1.23	31.2
7.12	181.0	116	1.85	47.0	1.18	30.0
7.02	178.5	120	1.90	48.5	1.13	28.7

1 Flange diameter is 10.83 in. (275 mm)  
2 Wear Chart: 5338

# D8N, D8R, D8T - 8.50 in. (215.9 mm)

## Track Rollers with End Caps <sup>(1) (2)</sup> Single Flange General Duty

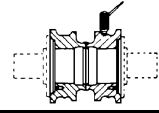
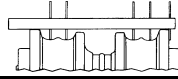

Caliper		% Worn	Depth Gauge		Ultrasonic	
Inches	(mm)		Inches	(mm)	Inches	(mm)
9.72	(247.0)	0	0.55	(14.0)	2.48	(63.0)
9.62	(244.5)	6	0.60	(15.0)	2.43	(61.7)
9.52	(242.0)	12	0.65	(16.5)	2.38	(60.5)
9.42	(239.5)	18	0.70	(18.0)	2.33	(59.2)
9.32	(236.5)	24	0.75	(19.0)	2.28	(57.9)
9.22	(234.0)	30	0.80	(20.5)	2.23	(56.6)
9.12	(231.5)	36	0.85	(21.5)	2.18	(55.4)
9.02	(229.0)	42	0.90	(23.0)	2.13	(54.1)
8.92	(226.5)	48	0.95	(24.0)	2.08	(52.8)
8.82	(224.0)	54	1.00	(25.5)	2.03	(51.6)
8.72	(221.5)	58	1.05	(26.5)	1.98	(50.3)
8.62	(219.0)	61	1.10	(28.0)	1.93	(49.0)
8.52	(216.5)	65	1.15	(29.0)	1.88	(47.8)
8.42	(214.0)	68	1.20	(30.5)	1.83	(46.5)
8.32	(211.5)	72	1.25	(32.0)	1.78	(45.2)
8.22	(209.0)	75	1.30	(33.0)	1.73	(43.9)
8.12	(206.0)	79	1.35	(34.5)	1.68	(42.7)
8.02	(203.5)	82	1.40	(35.5)	1.63	(41.4)
7.92	(201.0)	86	1.45	(37.0)	1.58	(40.1)
7.82	(198.5)	89	1.50	(38.0)	1.53	(38.9)
7.72	(196.0)	93	1.55	(39.5)	1.48	(37.6)
7.62	(193.5)	96	1.60	(40.5)	1.43	(36.3)
7.52	(191.0)	100	1.65	(42.0)	1.38	(35.1)
7.42	(188.5)	104	1.70	(43.0)	1.33	(33.8)
7.32	(186.0)	107	1.75	(44.5)	1.28	(32.5)
7.22	(183.5)	111	1.80	(45.5)	1.23	(31.2)
7.12	(181.0)	114	1.85	(47.0)	1.18	(30.0)
7.02	(178.5)	118	1.90	(48.5)	1.13	(28.7)
6.92	(176.0)	121	1.95	(49.5)	1.08	(27.4)

1 Flange diameter is 10.83 in. (275 mm)

2 Wear Chart: 5322



**D8L, D8N, D8R, D8T, 578, 583R, 583T, 587R, 587T, PL83, PL87 - 8.50 in. (215.9 mm)**

**Track Rollers <sup>(1) (2)</sup>  
Double Flange**

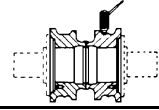
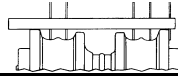
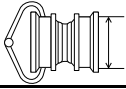

Caliper		% Worn	Depth Gauge		Ultrasonic	
Inches	(mm)		Inches	(mm)	Inches	(mm)
9.49	(241.0)	0	0.67	(17.0)	2.37	(60.2)
9.39	(238.5)	6	0.72	(18.5)	2.32	(58.9)
9.29	(236.0)	12	0.77	(19.5)	2.27	(57.7)
9.19	(233.5)	18	0.82	(21.0)	2.22	(56.4)
9.09	(231.0)	24	0.87	(22.0)	2.17	(55.1)
8.99	(228.5)	30	0.92	(23.5)	2.12	(53.8)
8.89	(226.0)	36	0.97	(24.5)	2.07	(52.6)
8.79	(223.5)	42	1.02	(26.0)	2.02	(51.3)
8.69	(220.5)	48	1.07	(27.0)	1.97	(50.0)
8.59	(218.0)	54	1.12	(28.5)	1.92	(48.8)
8.49	(215.5)	60	1.17	(29.5)	1.87	(47.5)
8.39	(213.0)	66	1.22	(31.0)	1.82	(46.2)
8.29	(210.5)	72	1.27	(32.5)	1.77	(45.0)
8.19	(208.0)	78	1.32	(33.5)	1.72	(43.7)
8.09	(205.5)	82	1.37	(35.0)	1.67	(42.4)
7.99	(203.0)	85	1.42	(36.0)	1.62	(41.1)
7.89	(200.5)	88	1.47	(37.5)	1.57	(39.9)
7.79	(198.0)	91	1.52	(38.5)	1.52	(38.6)
7.69	(195.5)	94	1.57	(40.0)	1.47	(37.3)
7.59	(193.0)	97	1.62	(41.0)	1.42	(36.1)
7.49	(190.0)	100	1.67	(42.5)	1.37	(34.8)
7.39	(187.5)	103	1.72	(43.5)	1.32	(33.5)
7.29	(185.0)	106	1.77	(45.0)	1.27	(32.3)
7.19	(182.5)	109	1.82	(46.0)	1.22	(31.0)
7.09	(180.0)	112	1.87	(47.5)	1.17	(29.7)
6.99	(177.5)	115	1.92	(49.0)	1.12	(28.4)
6.89	(175.0)	118	1.97	(50.0)	1.07	(27.2)
6.79	(172.5)	121	2.02	(51.5)	1.02	(25.9)

1 Flange diameter is 10.83 in. (275 mm)

2 Wear Chart: 6230

# D8N, D8R, D8T - 8.58 in. (218 mm)

## Sprockets <sup>(1)</sup> SystemOne Track



### Tape Measure

Inches	(mm)	% Worn
9.33	(237.0)	0
9.28	(235.5)	7
9.23	(234.5)	14
9.18	(233.0)	21
9.13	(232.0)	28
9.08	(230.5)	35
9.03	(229.5)	42
8.98	(228.0)	49
8.93	(227.0)	56
8.88	(225.5)	63
8.83	(224.5)	70
8.78	(223.0)	77
8.73	(221.5)	84
8.68	(220.5)	90
8.63	(219.0)	95
8.58	(218.0)	100
8.53	(216.5)	105
8.48	(215.5)	110
8.43	(214.0)	115
8.38	(213.0)	120

#### NOTE

Measure across 3 teeth.

**D8N, D8R, D8T, 578, 583R, 583T, 587R, 587T, PL83, PL87 - 8.50 in. (215.9 mm)**

**Sprockets <sup>(1)</sup>**  
**Do not use with D8L**



**Tape Measure**

<b>Inches</b>	<b>(mm)</b>	<b>% Worn</b>
9.40	(239.0)	0
9.35	(237.5)	7
9.30	(236.0)	14
9.25	(235.0)	21
9.20	(233.5)	28
9.15	(232.5)	35
9.10	(231.0)	40
9.05	(230.0)	45
9.00	(228.5)	50
8.95	(227.5)	55
8.90	(226.0)	60
8.85	(225.0)	65
8.80	(223.5)	70
8.75	(222.5)	75
8.70	(221.0)	80
8.65	(219.5)	85
8.60	(218.5)	90
8.55	(217.0)	95
8.50	(216.0)	100
8.45	(214.5)	105
8.40	(213.5)	110
8.35	(212.0)	115
8.30	(211.0)	120

**NOTE**

Measure across 3 teeth

# D8L - 8.50 in. (215.9 mm)

## Sprockets <sup>(1)</sup> Use with D8L only



### Tape Measure

Inches	(mm)	% Worn
9.25	(235.0)	0
9.20	(233.5)	8
9.15	(232.5)	16
9.10	(231.0)	24
9.05	(230.0)	32
9.00	(228.5)	40
8.95	(227.5)	46
8.90	(226.0)	52
8.85	(225.0)	58
8.80	(223.5)	64
8.75	(222.5)	70
8.70	(221.0)	76
8.65	(219.5)	82
8.60	(218.5)	88
8.55	(217.0)	94
8.50	(216.0)	100
8.45	(214.5)	106
8.40	(213.5)	112
8.35	(212.0)	118
8.30	(211.0)	124

#### NOTE

Measure across 3 teeth

# D9N, D9R, D9T - 9.45 in. (240 mm)

## Track Links <sup>(1)</sup> 9W-2743 & 44 7T-2275 & 76

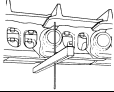

Depth Gauge		Allowable Wear Greater % <sup>(2)</sup> Worn	Ultrasonic	
Inches	(mm)		Inches	(mm)
6.53	(166.0)	0	2.28	(57.9)
6.51	(165.5)	4	2.26	(57.4)
6.49	(165.0)	8	2.24	(56.9)
6.47	(164.5)	12	2.22	(56.4)
6.45	(164.0)	16	2.20	(55.9)
6.43	(163.5)	20	2.18	(55.4)
6.41	(163.0)	24	2.16	(54.9)
6.39	(162.5)	28	2.14	(54.4)
6.37	(162.0)	32	2.12	(53.8)
6.35	(161.5)	36	2.10	(53.3)
6.33	(161.0)	40	2.08	(52.8)
6.31	(160.5)	44	2.06	(52.3)
6.29	(160.0)	48	2.04	(51.8)
6.27	(159.5)	52	2.02	(51.3)
6.25	(159.0)	55	2.00	(50.8)
6.23	(158.0)	57	1.98	(50.3)
6.21	(157.5)	60	1.96	(49.8)
6.19	(157.0)	62	1.94	(49.3)
6.17	(156.5)	65	1.92	(48.8)
6.15	(156.0)	67	1.90	(48.3)
6.13	(155.5)	70	1.88	(47.8)
6.11	(155.0)	72	1.86	(47.2)
6.09	(154.5)	75	1.84	(46.7)
6.07	(154.0)	77	1.82	(46.2)
6.05	(153.5)	80	1.80	(45.7)
6.03	(153.0)	82	1.78	(45.2)
6.01	(152.5)	85	1.76	(44.7)
5.99	(152.0)	87	1.74	(44.2)
5.97	(151.5)	90	1.72	(43.7)
5.95	(151.0)	92	1.70	(43.2)
5.93	(150.5)	95	1.68	(42.7)
5.91	(150.0)	97	1.66	(42.2)
5.89	(149.5)	100	1.64	(41.7)
5.87	(149.0)	102	1.62	(41.1)
5.85	(148.5)	105	1.60	(40.6)
5.83	(148.0)	107	1.58	(40.1)
5.81	(147.5)	110	1.56	(39.6)
5.79	(147.0)	112	1.54	(39.1)
5.77	(146.5)	115	1.52	(38.6)
5.75	(146.0)	117	1.50	(38.1)
5.73	(145.5)	120	1.48	(37.6)

1 Wear Chart: 160

2 If 9W-2743 & 44, 7T-2275 & 76 link cracking has been experienced, please use the Lesser Allowable Wear chart located on, page 276 at the end of the Elevated Sprocket Machine Section. Also see, page 88 for further definition of Link Allowable Wear.

# D9N, D9R, D9T - 9.45 in. (240 mm)

## Bushings <sup>(1)</sup> Sealed & Lubricated Track

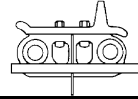
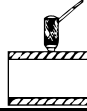

Caliper		Allowable Wear		Ultrasonic		Depth Gauge	
Inches	(mm)	Lesser % Worn	Greater % Worn	Inches	(mm)	Inches	(mm)
3.34	(84.8)	0	0	0.65	(16.5)	4.35	(110.5)
3.32	(84.3)	10	8	0.63	(16.0)	4.33	(110.0)
3.30	(83.8)	20	16	0.61	(15.5)	4.31	(109.5)
3.28	(83.3)	30	24	0.59	(15.0)	4.29	(109.0)
3.26	(82.8)	40	32	0.57	(14.5)	4.27	(108.5)
3.24	(82.3)	50	40	0.55	(14.0)	4.25	(108.0)
3.22	(81.8)	60	44	0.53	(13.5)	4.23	(107.4)
3.20	(81.3)	68	48	0.51	(13.0)	4.21	(106.9)
3.18	(80.8)	72	52	0.49	(12.4)	4.19	(106.4)
3.16	(80.3)	76	56	0.47	(11.9)	4.17	(105.9)
3.14	(79.8)	80	60	0.45	(11.4)	4.15	(105.4)
3.12	(79.2)	84	64	0.43	(10.9)	4.13	(104.9)
3.10	(78.7)	88	68	0.41	(10.4)	4.11	(104.4)
3.08	(78.2)	92	72	0.39	(9.9)	4.09	(103.9)
3.06	(77.7)	96	76	0.37	(9.4)	4.07	(103.4)
3.04	(77.2)	100	80	0.35	(8.9)	4.05	(102.9)
3.02	(76.7)	104	84	0.33	(8.4)	4.03	(102.4)
3.00	(76.2)	108	88	0.31	(7.9)	4.01	(101.9)
2.98	(75.7)	112	92	0.29	(7.4)	3.99	(101.3)
2.96	(75.2)	116	96	0.27	(6.9)	3.97	(100.8)
2.94	(74.7)	120	100	0.25	(6.3)	3.95	(100.3)
2.92	(74.2)		104	0.23	(5.8)	3.93	(99.8)
2.90	(73.7)		108	0.21	(5.3)	3.91	(99.3)
2.88	(73.2)		112	0.19	(4.8)	3.89	(98.8)
2.86	(72.6)		116	0.17	(4.3)	3.87	(98.3)
2.84	(72.1)		120	0.15	(3.8)	3.85	(97.8)

**Note: Do Not Use Depth Gauge Until Bushings Have Been "Turned."**

# D9N, D9R, D9T - 9.45 in. (240 mm)

## Track Shoes <sup>(1)</sup> Super Extreme Service

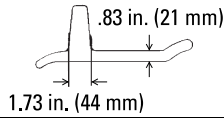
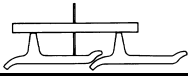

Depth Gauge		High Impact	Low/Moderate	Ultrasonic	
Inches	(mm)	% Worn	Impact % Worn	Inches	(mm)
3.70	(94.0)	0	0	4.50	(114.3)
3.60	(91.5)	5	4	4.40	(111.8)
3.50	(89.0)	10	8	4.30	(109.2)
3.40	(86.5)	15	12	4.20	(106.7)
3.30	(84.0)	20	16	4.10	(104.1)
3.20	(81.5)	25	20	4.00	(101.6)
3.10	(78.5)	30	24	3.90	(99.1)
3.00	(76.0)	35	28	3.80	(96.5)
2.90	(73.5)	40	32	3.70	(94.0)
2.80	(71.0)	45	36	3.60	(91.4)
2.70	(68.5)	50	40	3.50	(89.9)
2.60	(66.0)	55	44	3.40	(86.4)
2.50	(63.5)	60	48	3.30	(83.8)
2.40	(61.0)	64	52	3.20	(81.3)
2.30	(58.5)	68	56	3.10	(78.7)
2.20	(56.0)	72	60	3.00	(76.2)
2.10	(53.5)	76	64	2.90	(73.7)
2.00	(51.0)	80	68	2.80	(71.1)
1.90	(48.5)	84	72	2.70	(68.6)
1.80	(45.5)	88	76	2.60	(66.0)
1.70	(43.0)	92	79	2.50	(63.5)
1.60	(40.5)	96	82	2.40	(61.0)
1.50	(38.0)	100	85	2.30	(58.4)
1.40	(35.5)	104	88	2.20	(55.9)
1.30	(33.0)	108	91	2.10	(53.3)
1.20	(30.5)	112	94	2.00	(50.8)
1.10	(28.0)	116	97	1.90	(48.3)
1.00	(25.5)	120	100	1.80	(45.7)
0.90	(23.0)		103	1.70	(43.2)
0.80	(20.5)		106	1.60	(40.6)
0.70	(18.0)		109	1.50	(38.1)
0.60	(15.0)		112	1.40	(35.6)
0.50	(12.5)		115	1.30	(33.0)
0.40	(10.0)		118	1.20	(30.5)
0.30	(7.5)		121	1.10	(27.9)

# D9N, D9R, D9T - 9.45 in. (240 mm)

## Track Shoes <sup>(1)</sup> Extreme Service

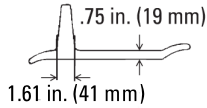
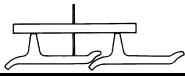

Depth Gauge		High Impact	Low/Moderate	Ultrasonic	
Inches	(mm)	% Worn	Impact % Worn	Inches	(mm)
3.30	(84.0)	0	0	4.05	(102.9)
3.20	(81.5)	6	5	3.95	(100.3)
3.10	(78.5)	12	10	3.85	(97.8)
3.00	(76.0)	18	15	3.75	(95.3)
2.90	(73.5)	24	20	3.65	(92.7)
2.80	(71.0)	30	25	3.55	(90.2)
2.70	(68.5)	36	30	3.45	(87.6)
2.60	(66.0)	42	35	3.35	(85.1)
2.50	(63.5)	48	40	3.25	(82.6)
2.40	(61.0)	54	44	3.15	(80.0)
2.30	(58.5)	60	48	3.05	(77.5)
2.20	(56.0)	65	52	2.95	(74.9)
2.10	(53.5)	70	56	2.85	(72.4)
2.00	(51.0)	75	60	2.75	(69.9)
1.90	(48.5)	80	64	2.65	(67.3)
1.80	(45.5)	85	68	2.55	(64.8)
1.70	(43.0)	90	72	2.45	(62.2)
1.60	(40.5)	95	76	2.35	(59.7)
1.50	(38.0)	100	80	2.25	(57.1)
1.40	(35.5)	105	84	2.15	(54.6)
1.30	(33.0)	110	88	2.05	(52.1)
1.20	(30.5)	115	92	1.95	(49.5)
1.10	(28.0)	120	96	1.85	(47.0)
1.00	(25.5)		100	1.75	(44.4)
0.90	(23.0)		104	1.65	(41.9)
0.80	(20.5)		108	1.55	(39.4)
0.70	(18.0)		112	1.45	(36.8)
0.60	(15.0)		116	1.35	(34.3)
0.50	(12.5)		120	1.25	(31.7)



**Track Shoes <sup>(1)</sup>  
Moderate Service**

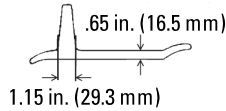
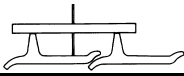

Depth Gauge		High Impact	Low/Moderate	Ultrasonic	
Inches	(mm)	% Worn	Impact % Worn	Inches	(mm)
3.00	(76.0)	0	0	3.65	(92.7)
2.90	(73.5)	7	5	3.55	(90.2)
2.80	(71.0)	14	10	3.45	(87.6)
2.70	(68.5)	21	15	3.35	(85.1)
2.60	(66.0)	28	20	3.25	(82.6)
2.50	(63.5)	35	25	3.15	(80.0)
2.40	(61.0)	42	30	3.05	(77.5)
2.30	(58.5)	49	35	2.95	(74.9)
2.20	(56.0)	56	40	2.85	(72.4)
2.10	(53.5)	63	45	2.75	(69.9)
2.00	(51.0)	70	50	2.65	(67.3)
1.90	(48.5)	76	55	2.55	(64.8)
1.80	(45.5)	82	60	2.45	(62.2)
1.70	(43.0)	88	65	2.35	(59.7)
1.60	(40.5)	94	70	2.25	(57.2)
1.50	(38.0)	100	75	2.15	(54.6)
1.40	(35.5)	106	80	2.05	(52.1)
1.30	(33.0)	112	85	1.95	(49.5)
1.20	(30.5)	118	90	1.85	(47.0)
1.10	(28.0)	124	95	1.75	(44.5)
1.00	(25.5)		100	1.65	(41.9)
0.90	(23.0)		104	1.55	(39.4)
0.80	(20.5)		108	1.45	(36.8)
0.70	(18.0)		112	1.35	(34.3)
0.60	(15.0)		116	1.25	(31.7)
0.50	(12.5)		120	1.15	(29.2)

# D9N, D9R, D9T - 9.45 in. (240 mm)

## Track Shoes <sup>(1)</sup> Chopper

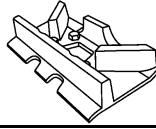

Depth Gauge			Ultrasonic	
Inches	(mm)	% Worn	Inches	(mm)
3.90	(99.0)	0	4.49	(114.0)
3.80	(96.5)	4	4.39	(111.5)
3.70	(94.0)	8	4.29	(108.9)
3.60	(91.5)	12	4.19	(106.4)
3.50	(89.0)	16	4.09	(103.8)
3.40	(86.5)	20	3.99	(101.3)
3.30	(84.0)	24	3.89	(98.8)
3.20	(81.5)	28	3.79	(96.2)
3.10	(78.5)	32	3.69	(93.7)
3.00	(76.0)	36	3.59	(91.1)
2.90	(73.5)	40	3.49	(88.6)
2.80	(71.0)	44	3.39	(86.1)
2.70	(68.5)	48	3.29	(83.5)
2.60	(66.0)	52	3.19	(81.0)
2.50	(63.5)	55	3.09	(78.4)
2.40	(61.0)	58	2.99	(75.9)
2.30	(58.5)	61	2.89	(73.4)
2.20	(56.0)	64	2.79	(70.8)
2.10	(53.5)	67	2.69	(68.3)
2.00	(51.0)	70	2.59	(65.7)
1.90	(48.5)	73	2.49	(63.2)
1.80	(45.5)	76	2.39	(60.7)
1.70	(43.0)	79	2.29	(58.1)
1.60	(40.5)	82	2.19	(55.6)
1.50	(38.0)	85	2.09	(53.0)
1.40	(35.5)	88	1.99	(50.5)
1.30	(33.0)	91	1.89	(48.0)
1.20	(30.5)	94	1.79	(45.4)
1.10	(28.0)	97	1.69	(42.9)
1.00	(25.5)	100	1.59	(40.3)
0.90	(23.0)	103	1.49	(37.8)
0.80	(20.5)	106	1.39	(35.3)
0.70	(18.0)	109	1.29	(32.7)
0.60	(15.0)	112	1.19	(30.2)
0.50	(12.5)	115	1.09	(27.6)
0.40	(10.0)	118	0.99	(25.1)
0.30	(7.5)	121	0.89	(22.6)

**Idlers** <sup>(1)</sup> <sup>(2)</sup> <sup>(3)</sup>

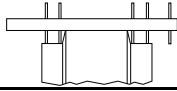

**Depth Gauge**

<b>Inches</b>	<b>(mm)</b>	<b>% Worn</b>
0.78	(20.0)	0
0.82	(21.0)	8
0.86	(22.0)	16
0.90	(23.0)	24
0.94	(24.0)	32
0.98	(25.0)	40
1.02	(26.0)	48
1.06	(27.0)	56
1.10	(28.0)	64
1.14	(29.0)	72
1.18	(30.0)	76
1.22	(31.0)	80
1.26	(32.0)	84
1.30	(33.0)	88
1.34	(34.0)	92
1.38	(35.0)	96
1.42	(36.0)	100
1.46	(37.0)	104
1.50	(38.0)	108
1.54	(39.0)	112
1.58	(40.0)	116
1.62	(41.0)	120

- 1 Flange width is 4.37 in. (111 mm)
- 2 New tread diameter is 28.35 in. (720 mm)
- 3 Wear Chart: 4460

# D9N, D9R, D9T - 9.45 in. (240 mm)

## Track Rollers <sup>(1) (2)</sup> Single Flange

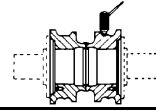
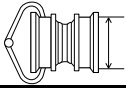

Caliper		% Worn	Depth Gauge		Ultrasonic	
Inches	(mm)		Inches	(mm)	Inches	(mm)
10.23	(260.0)	0	0.59	(15.0)	2.74	(69.6)
10.13	(257.5)	5	0.64	(16.5)	2.69	(68.3)
10.03	(255.0)	10	0.69	(17.5)	2.64	(67.1)
9.93	(252.0)	15	0.74	(19.0)	2.59	(65.8)
9.83	(249.5)	20	0.79	(20.0)	2.54	(64.5)
9.73	(247.0)	25	0.84	(21.5)	2.49	(63.2)
9.63	(244.5)	30	0.89	(22.5)	2.44	(62.0)
9.53	(242.0)	34	0.94	(24.0)	2.39	(60.7)
9.43	(239.5)	37	0.99	(25.0)	2.34	(59.4)
9.33	(237.0)	40	1.04	(26.5)	2.29	(58.2)
9.23	(234.5)	43	1.09	(27.5)	2.24	(56.9)
9.13	(232.0)	46	1.14	(29.0)	2.19	(55.6)
9.03	(229.5)	49	1.19	(30.0)	2.14	(54.4)
8.93	(227.0)	52	1.24	(31.5)	2.09	(53.1)
8.83	(224.5)	55	1.29	(33.0)	2.04	(51.8)
8.73	(221.5)	58	1.34	(34.0)	1.99	(50.5)
8.63	(219.0)	61	1.39	(35.5)	1.94	(49.3)
8.53	(216.5)	64	1.44	(36.5)	1.89	(48.0)
8.43	(214.0)	67	1.49	(38.0)	1.84	(46.7)
8.33	(211.5)	70	1.54	(39.0)	1.79	(45.5)
8.23	(209.0)	73	1.59	(40.5)	1.74	(44.2)
8.13	(206.5)	76	1.64	(41.5)	1.69	(42.9)
8.03	(204.0)	79	1.69	(43.0)	1.64	(41.7)
7.93	(201.5)	82	1.74	(44.0)	1.59	(40.4)
7.83	(199.0)	85	1.79	(45.5)	1.54	(39.1)
7.73	(196.5)	88	1.84	(46.5)	1.49	(37.8)
7.63	(194.0)	91	1.89	(48.0)	1.44	(36.6)
7.53	(191.5)	94	1.94	(49.5)	1.39	(35.3)
7.43	(188.5)	97	1.99	(50.5)	1.34	(34.0)
7.33	(186.0)	100	2.04	(52.0)	1.29	(32.8)
7.23	(183.5)	103	2.09	(53.0)	1.24	(31.5)
7.13	(181.0)	106	2.14	(54.5)	1.19	(30.2)
7.03	(178.5)	109	2.19	(55.5)	1.14	(29.0)
6.93	(176.0)	112	2.24	(57.0)	1.09	(27.7)
6.83	(173.5)	115	2.29	(58.0)	1.04	(26.4)
6.73	(171.0)	118	2.34	(59.5)	0.99	(25.1)
6.63	(168.5)	121	2.39	(60.5)	0.94	(23.9)
6.53	(166.0)	124	2.44	(62.0)	0.89	(22.6)
6.43	(163.5)	127	2.49	(63.0)	0.84	(21.3)

1 Flange diameter is 11.42 in. (290 mm)

2 Wear Chart: 5360

# D9N, D9R, D9T - 9.45 in. (240 mm)

## Track Rollers <sup>(1) (2)</sup> Double Flange

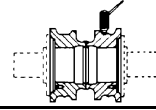
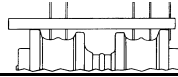
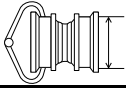

Caliper			Depth Gauge		Ultrasonic	
Inches	(mm)	% Worn	Inches	(mm)	Inches	(mm)
9.84	(250.0)	0	0.78	(20.0)	2.54	(64.5)
9.74	(247.5)	5	0.83	(21.0)	2.49	(63.2)
9.64	(245.0)	10	0.88	(22.5)	2.44	(62.0)
9.54	(242.5)	15	0.93	(23.5)	2.39	(60.7)
9.44	(240.0)	20	0.98	(25.0)	2.34	(59.4)
9.34	(237.0)	25	1.03	(26.0)	2.29	(58.2)
9.24	(234.5)	30	1.08	(27.5)	2.24	(56.9)
9.14	(232.0)	35	1.13	(28.5)	2.19	(55.6)
9.04	(229.5)	40	1.18	(30.0)	2.14	(54.4)
8.94	(227.0)	45	1.23	(31.0)	2.09	(53.1)
8.84	(224.5)	50	1.28	(32.5)	2.04	(51.8)
8.74	(222.0)	55	1.33	(34.0)	1.99	(50.5)
8.64	(219.5)	60	1.38	(35.0)	1.94	(49.3)
8.54	(217.0)	65	1.43	(36.5)	1.89	(48.0)
8.44	(214.5)	70	1.48	(37.5)	1.84	(46.7)
8.34	(212.0)	73	1.53	(39.0)	1.79	(45.5)
8.24	(209.5)	76	1.58	(40.0)	1.74	(44.2)
8.14	(207.0)	79	1.63	(41.5)	1.69	(42.9)
8.04	(204.0)	82	1.68	(42.5)	1.64	(41.7)
7.94	(201.5)	85	1.73	(44.0)	1.59	(40.4)
7.84	(199.0)	88	1.78	(45.0)	1.54	(39.1)
7.74	(196.5)	91	1.83	(46.5)	1.49	(37.8)
7.64	(194.0)	94	1.88	(48.0)	1.44	(36.6)
7.54	(191.5)	97	1.93	(49.0)	1.39	(35.3)
7.44	(189.0)	100	1.98	(50.5)	1.34	(34.0)
7.34	(186.5)	103	2.03	(51.5)	1.29	(32.8)
7.24	(184.0)	106	2.08	(53.0)	1.24	(31.5)
7.14	(181.5)	109	2.13	(54.0)	1.19	(30.2)
7.04	(179.0)	112	2.18	(55.5)	1.14	(29.0)
6.94	(176.5)	115	2.23	(56.5)	1.09	(27.7)
6.84	(173.5)	118	2.28	(58.0)	1.04	(26.4)
6.74	(171.0)	121	2.33	(59.0)	0.99	(25.1)
6.64	(168.5)	124	2.38	(60.5)	0.94	(23.9)
6.54	(166.0)	127	2.43	(61.5)	0.89	(22.6)
6.44	(163.5)	130	2.48	(63.0)	0.84	(21.3)

1 Flange diameter is 11.42 in. (290 mm)

2 Wear Chart: 6260

# D9N, D9R, D9T - 9.45 in. (240 mm)

## Sprockets <sup>(1)</sup>



Tape Measure		
Inches	(mm)	% Worn
10.50	(266.5)	0
10.45	(265.5)	5
10.40	(264.0)	10
10.35	(263.0)	15
10.30	(261.5)	20
10.25	(260.5)	25
10.20	(259.0)	30
10.15	(258.0)	35
10.10	(256.5)	40
10.05	(255.5)	45
10.00	(254.0)	50
9.95	(252.5)	55
9.90	(251.5)	60
9.85	(250.0)	65
9.80	(249.0)	70
9.75	(247.5)	75
9.70	(246.5)	80
9.65	(245.0)	84
9.60	(244.0)	88
9.55	(242.5)	92
9.50	(241.5)	96
9.45	(240.0)	100
9.40	(239.0)	104
9.35	(237.5)	108
9.30	(236.0)	112
9.25	(235.0)	116
9.20	(233.5)	120

### NOTE

Measure across 3 teeth

**Track Links <sup>(1)</sup>**  
**7T-7629 & 30**  
**7T-4137 & 38**

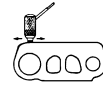
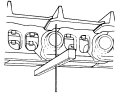

Depth Gauge		Allowable Wear Greater % <sup>(2)</sup> Worn	Ultrasonic	
Inches	(mm)		Inches	(mm)
6.34	(161.0)	0	1.85	(47.0)
6.32	(160.5)	4	1.83	(46.5)
6.30	(160.0)	8	1.81	(46.0)
6.28	(159.5)	12	1.79	(45.5)
6.26	(159.0)	16	1.77	(45.0)
6.24	(158.5)	20	1.75	(44.5)
6.22	(158.0)	24	1.73	(43.9)
6.20	(157.5)	28	1.71	(43.4)
6.18	(157.0)	32	1.69	(42.9)
6.16	(156.5)	36	1.67	(42.4)
6.14	(156.0)	40	1.65	(41.9)
6.12	(155.5)	44	1.63	(41.4)
6.10	(155.0)	48	1.61	(40.9)
6.08	(154.5)	52	1.59	(40.4)
6.06	(154.0)	55	1.57	(39.9)
6.04	(153.5)	57	1.55	(39.4)
6.02	(153.0)	60	1.53	(38.9)
6.00	(152.5)	62	1.51	(38.4)
5.98	(152.0)	65	1.49	(37.8)
5.96	(151.5)	67	1.47	(37.3)
5.94	(151.0)	70	1.45	(36.8)
5.92	(150.5)	72	1.43	(36.3)
5.90	(150.0)	75	1.41	(35.8)
5.88	(149.5)	77	1.39	(35.3)
5.86	(149.0)	80	1.37	(34.8)
5.84	(148.5)	82	1.35	(34.3)
5.82	(148.0)	85	1.33	(33.8)
5.80	(147.5)	87	1.31	(33.3)
5.78	(147.0)	90	1.29	(32.8)
5.76	(146.5)	92	1.27	(32.3)
5.74	(146.0)	95	1.25	(31.8)
5.72	(145.5)	97	1.23	(31.2)
5.70	(145.0)	100	1.21	(30.7)
5.68	(144.5)	102	1.19	(30.2)
5.66	(144.0)	105	1.17	(29.7)
5.64	(143.5)	107	1.15	(29.2)
5.62	(142.5)	110	1.13	(28.7)
5.60	(142.0)	112	1.11	(28.2)
5.58	(141.5)	115	1.09	(27.7)
5.56	(141.0)	117	1.07	(27.2)
5.54	(140.5)	120	1.05	(26.7)

1 Wear Chart: 141

2 If 7T-7629 & 30, 7T-4137 & 38 link cracking has been experienced, please use the Lesser Allowable Wear chart located on, page 277 at the end of the Elevated Sprocket Machine Section. See, page 88 for further definition of Link Allowable Wear.

# D9L, 589 — 9.00 in. (228.6 mm)

## Bushings <sup>(1)</sup> Sealed & Lubricated Track

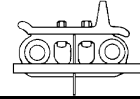
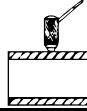

Caliper		Allowable Wear		Ultrasonic		Depth Gauge	
Inches	(mm)	Lesser % Worn	Greater % Worn	Inches	(mm)	Inches	(mm)
3.34	(84.8)	0	0	0.65	(16.5)	4.54	(115.3)
3.32	(84.3)	10	8	0.63	(16.0)	4.52	(114.8)
3.30	(83.8)	20	16	0.61	(15.5)	4.50	(114.3)
3.28	(83.3)	30	24	0.59	(15.0)	4.48	(113.8)
3.26	(82.8)	40	32	0.57	(14.5)	4.46	(113.3)
3.24	(82.3)	50	40	0.55	(14.0)	4.44	(112.8)
3.22	(81.8)	60	44	0.53	(13.5)	4.42	(112.3)
3.20	(81.3)	68	48	0.51	(13.0)	4.40	(111.8)
3.18	(80.8)	72	52	0.49	(12.4)	4.38	(111.3)
3.16	(80.3)	76	56	0.47	(11.9)	4.36	(110.7)
3.14	(79.8)	80	60	0.45	(11.4)	4.34	(110.2)
3.12	(79.2)	84	64	0.43	(10.9)	4.32	(109.7)
3.10	(78.7)	88	68	0.41	(10.4)	4.30	(109.2)
3.08	(78.2)	92	72	0.39	(9.9)	4.28	(108.7)
3.06	(77.7)	96	76	0.37	(9.4)	4.26	(108.2)
3.04	(77.2)	100	80	0.35	(8.9)	4.24	(107.7)
3.02	(76.7)	104	84	0.33	(8.4)	4.22	(107.2)
3.00	(76.2)	108	88	0.31	(7.9)	4.20	(106.7)
2.98	(75.7)	112	92	0.29	(7.4)	4.18	(106.2)
2.96	(75.2)	116	96	0.27	(6.9)	4.16	(105.7)
2.94	(74.7)	120	100	0.25	(6.3)	4.14	(105.2)
2.92	(74.2)		104	0.23	(5.8)	4.12	(104.6)
2.90	(73.7)		108	0.21	(5.3)	4.10	(104.1)
2.88	(73.2)		112	0.19	(4.8)	4.08	(103.6)
2.86	(72.6)		116	0.17	(4.3)	4.06	(103.1)
2.84	(72.1)		120	0.15	(3.8)	4.04	(102.6)

**Note: Do Not Use Depth Gauge Until Bushings Have Been "Turned."**

1 Wear Chart: 742



**Track Shoes <sup>(1)</sup>  
Extreme Service**



Depth Gauge		High Impact	Low/Moderate	Ultrasonic	
Inches	(mm)	% Worn	Impact % Worn	Inches	(mm)
3.70	(94.0)	0	0	4.50	(114.3)
3.60	(91.5)	5	4	4.40	(111.8)
3.50	(89.0)	10	8	4.30	(109.2)
3.40	(86.5)	15	12	4.20	(106.7)
3.30	(84.0)	20	16	4.10	(104.1)
3.20	(81.5)	25	20	4.00	(101.6)
3.10	(78.5)	30	24	3.90	(99.1)
3.00	(76.0)	35	28	3.80	(96.5)
2.90	(73.5)	40	32	3.70	(94.0)
2.80	(71.0)	45	36	3.60	(91.4)
2.70	(68.5)	50	40	3.50	(88.9)
2.60	(66.0)	55	44	3.40	(86.4)
2.50	(63.5)	60	48	3.30	(83.8)
2.40	(61.0)	64	52	3.20	(81.3)
2.30	(58.5)	68	56	3.10	(78.7)
2.20	(56.0)	72	60	3.00	(76.2)
2.10	(53.5)	76	64	2.90	(73.7)
2.00	(51.0)	80	68	2.80	(71.1)
1.90	(48.5)	84	72	2.70	(68.6)
1.80	(45.5)	88	76	2.60	(66.0)
1.70	(43.0)	92	79	2.50	(63.5)
1.60	(40.5)	96	82	2.40	(61.0)
1.50	(38.0)	100	85	2.30	(58.4)
1.40	(35.5)	104	88	2.20	(55.9)
1.30	(33.0)	108	91	2.10	(53.3)
1.20	(30.5)	112	94	2.00	(50.8)
1.10	(28.0)	116	97	1.90	(48.3)
1.00	(25.5)	120	100	1.80	(45.7)
0.90	(23.0)		103	1.70	(43.2)
0.80	(20.5)		106	1.60	(40.6)
0.70	(18.0)		109	1.50	(38.1)
0.60	(15.0)		112	1.40	(35.6)
0.50	(12.5)		115	1.30	(33.0)
0.40	(10.0)		118	1.20	(30.5)
0.30	(7.5)		121	1.10	(27.9)

**D9L, 589 — 9.00 in. (228.6 mm)**

**Track Shoes <sup>(1)</sup>  
Moderate Service**

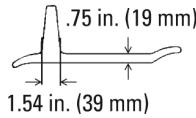
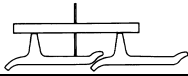

Depth Gauge		High Impact	Low/Moderate	Ultrasonic	
Inches	(mm)	% Worn	Impact % Worn	Inches	(mm)
3.10	(78.5)	0	0	3.85	(97.8)
3.00	(76.0)	7	5	3.75	(95.3)
2.90	(73.5)	14	10	3.65	(92.7)
2.80	(71.0)	21	15	3.55	(90.2)
2.70	(68.5)	28	20	3.45	(87.6)
2.60	(66.0)	34	25	3.35	(85.1)
2.50	(63.5)	40	30	3.25	(82.6)
2.40	(61.0)	46	35	3.15	(80.0)
2.30	(58.5)	52	40	3.05	(77.5)
2.20	(56.0)	58	45	2.95	(74.9)
2.10	(53.5)	64	50	2.85	(72.4)
2.00	(51.0)	70	55	2.75	(69.9)
1.90	(48.5)	76	60	2.65	(67.3)
1.80	(45.5)	82	65	2.55	(64.8)
1.70	(43.0)	88	70	2.45	(62.2)
1.60	(40.5)	94	75	2.35	(59.7)
1.50	(38.0)	100	80	2.25	(57.2)
1.40	(35.5)	106	84	2.15	(54.6)
1.30	(33.0)	112	88	2.05	(52.1)
1.20	(30.5)	118	92	1.95	(49.5)
1.10	(28.0)	124	96	1.85	(47.0)
1.00	(25.5)		100	1.75	(44.5)
0.90	(23.0)		104	1.65	(41.9)
0.80	(20.5)		108	1.55	(39.4)
0.70	(18.0)		112	1.45	(36.8)
0.60	(15.0)		116	1.35	(34.3)
0.50	(12.5)		120	1.25	(31.7)

Idlers <sup>(1)</sup> <sup>(2)</sup> <sup>(3)</sup>

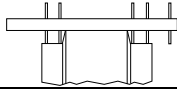

Depth Gauge

Inches	(mm)	% Worn
0.78	(20.0)	0
0.82	(21.0)	10
0.86	(22.0)	20
0.90	(23.0)	30
0.94	(24.0)	40
0.98	(25.0)	50
1.02	(26.0)	60
1.06	(27.0)	64
1.10	(28.0)	68
1.14	(29.0)	72
1.18	(30.0)	76
1.22	(31.0)	80
1.26	(32.0)	84
1.30	(33.0)	88
1.34	(34.0)	92
1.38	(35.0)	96
1.42	(36.0)	100
1.46	(37.0)	104
1.50	(38.0)	108
1.54	(39.0)	112
1.58	(40.0)	116
1.62	(41.0)	120

- 1 Flange width is 4.63 in. (117.5 mm)
- 2 New tread diameter is 29.25 in. (743 mm)
- 3 Wear Chart: 4442

# D9L, 589 — 9.00 in. (228.6 mm)

## Track Rollers <sup>(1) (2)</sup> Single Flange

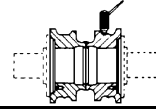
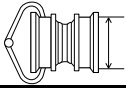

Caliper		% Worn	Depth Gauge		Ultrasonic	
Inches	(mm)		Inches	(mm)	Inches	(mm)
10.71	(272.0)	0	0.55	(14.0)	2.73	(69.3)
10.63	(270.0)	5	0.59	(15.0)	2.69	(68.3)
10.55	(268.0)	10	0.63	(16.0)	2.65	(67.3)
10.47	(266.0)	15	0.67	(17.0)	2.61	(66.3)
10.39	(264.0)	20	0.71	(18.0)	2.57	(65.3)
10.31	(262.0)	25	0.75	(19.0)	2.53	(64.3)
10.23	(260.0)	30	0.79	(20.0)	2.49	(63.2)
10.15	(258.0)	35	0.83	(21.0)	2.45	(62.2)
10.07	(256.0)	40	0.87	(22.0)	2.41	(61.2)
9.99	(253.5)	45	0.91	(23.0)	2.37	(60.2)
9.91	(251.5)	50	0.95	(24.0)	2.33	(59.2)
9.83	(249.5)	55	0.99	(25.0)	2.29	(58.2)
9.75	(247.5)	58	1.03	(26.0)	2.25	(57.2)
9.67	(245.5)	61	1.07	(27.0)	2.21	(56.1)
9.59	(243.5)	64	1.11	(28.0)	2.17	(55.1)
9.51	(241.5)	67	1.15	(29.0)	2.13	(54.1)
9.43	(239.5)	70	1.19	(30.0)	2.09	(53.1)
9.35	(237.5)	73	1.23	(31.0)	2.05	(52.1)
9.27	(235.5)	76	1.27	(32.5)	2.01	(51.1)
9.19	(233.5)	79	1.31	(33.5)	1.97	(50.0)
9.11	(231.5)	82	1.35	(34.5)	1.93	(49.0)
9.03	(229.5)	85	1.39	(35.5)	1.89	(48.0)
8.95	(227.5)	88	1.43	(36.5)	1.85	(47.0)
8.87	(225.5)	91	1.47	(37.5)	1.81	(46.0)
8.79	(223.5)	94	1.51	(38.5)	1.77	(45.0)
8.71	(221.0)	97	1.55	(39.5)	1.73	(43.9)
8.63	(219.0)	100	1.59	(40.5)	1.69	(42.9)
8.55	(217.0)	103	1.63	(41.5)	1.65	(41.9)
8.47	(215.0)	106	1.67	(42.5)	1.61	(40.9)
8.39	(213.0)	109	1.71	(43.5)	1.57	(39.9)
8.31	(211.0)	112	1.75	(44.5)	1.53	(38.9)
8.23	(209.0)	115	1.79	(45.5)	1.49	(37.8)
8.15	(207.0)	118	1.83	(46.5)	1.45	(36.8)
8.07	(205.0)	121	1.87	(47.5)	1.41	(35.8)

1 Flange diameter is 11.81 in. (300 mm)

2 Wear Chart: 5343

Track Rollers <sup>(1) (2)</sup>  
Double Flange

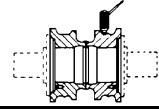
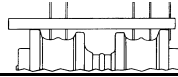
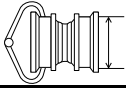

Caliper			Depth Gauge		Ultrasonic	
Inches	(mm)	% Worn	Inches	(mm)	Inches	(mm)
10.23	(260.0)	0	0.78	(20.0)	2.49	(63.2)
10.15	(258.0)	6	0.82	(21.0)	2.45	(62.2)
10.07	(256.0)	12	0.86	(22.0)	2.41	(61.2)
9.99	(253.5)	18	0.90	(23.0)	2.37	(60.2)
9.91	(251.5)	24	0.94	(24.0)	2.33	(59.2)
9.83	(249.5)	30	0.98	(25.0)	2.29	(58.2)
9.75	(247.5)	36	1.02	(26.0)	2.25	(57.2)
9.67	(245.5)	42	1.06	(27.0)	2.21	(56.1)
9.59	(243.5)	48	1.10	(28.0)	2.17	(55.1)
9.51	(241.5)	52	1.14	(29.0)	2.13	(54.1)
9.43	(239.5)	56	1.18	(30.0)	2.09	(53.1)
9.35	(237.5)	60	1.22	(31.0)	2.05	(52.1)
9.27	(235.5)	64	1.26	(32.0)	2.01	(51.1)
9.19	(233.5)	68	1.30	(33.0)	1.97	(50.0)
9.11	(231.5)	72	1.34	(34.0)	1.93	(49.0)
9.03	(229.5)	76	1.38	(35.0)	1.89	(48.0)
8.95	(227.5)	80	1.42	(36.0)	1.85	(47.0)
8.87	(225.5)	84	1.46	(37.0)	1.81	(46.0)
8.79	(223.5)	88	1.50	(38.0)	1.77	(45.0)
8.71	(221.0)	92	1.54	(39.0)	1.73	(43.9)
8.63	(219.0)	96	1.58	(40.0)	1.69	(42.9)
8.55	(217.0)	100	1.62	(41.0)	1.65	(41.9)
8.47	(215.0)	104	1.66	(42.0)	1.61	(40.9)
8.39	(213.0)	108	1.70	(43.0)	1.57	(39.9)
8.31	(211.0)	112	1.74	(44.0)	1.53	(38.9)
8.23	(209.0)	116	1.78	(45.0)	1.49	(37.8)
8.15	(207.0)	120	1.82	(46.0)	1.45	(36.8)

1 Flange diameter is 11.81 in. (300 mm)  
2 Wear Chart: 5342

# D9L, 589 — 9.00 in. (228.6 mm)

## Sprockets <sup>(1)</sup>



Tape Measure		
Inches	(mm)	% Worn
9.85	(250.0)	0
9.80	(249.0)	7
9.75	(247.5)	14
9.70	(246.5)	21
9.65	(245.0)	28
9.60	(244.0)	35
9.55	(242.5)	42
9.50	(241.5)	49
9.45	(240.0)	55
9.40	(239.0)	60
9.35	(237.5)	65
9.30	(236.0)	70
9.25	(235.0)	75
9.20	(233.5)	80
9.15	(232.5)	85
9.10	(231.0)	90
9.05	(230.0)	95
9.00	(228.5)	100
8.95	(227.5)	105
8.90	(226.0)	110
8.85	(225.0)	115
8.80	(223.5)	120

### NOTE

Measure across 3 teeth

1 Wear Chart: 7140

# D10N, D10R, D10T - 10.25 in. (260.4 mm)

Track Links <sup>(1)</sup>  
 9W-5265 & 66  
 7T-0715 & 16  
 320-3053 & 54  
 Standard Link or Scallop Resistant Link



Depth Gauge		Allowable Wear Greater % <sup>(2)</sup> Worn	Ultrasonic	
Inches	(mm)		Inches	(mm)
7.12	(181.0)	0	2.36	(59.9)
7.10	(180.5)	4	2.34	(59.4)
7.08	(180.0)	8	2.32	(58.9)
7.06	(179.5)	12	2.30	(58.4)
7.04	(179.0)	16	2.28	(57.9)
7.02	(178.5)	20	2.26	(57.4)
7.00	(178.0)	24	2.24	(56.9)
6.98	(177.5)	28	2.22	(56.4)
6.96	(177.0)	32	2.20	(55.9)
6.94	(176.5)	36	2.18	(55.4)
6.92	(176.0)	40	2.16	(54.9)
6.90	(175.5)	44	2.14	(54.4)
6.88	(175.0)	48	2.12	(53.8)
6.86	(174.0)	52	2.10	(53.3)
6.84	(173.5)	55	2.08	(52.8)
6.82	(173.0)	57	2.06	(52.3)
6.80	(172.5)	60	2.04	(51.8)
6.78	(172.0)	62	2.02	(51.3)
6.76	(171.5)	65	2.00	(50.8)
6.74	(171.0)	67	1.98	(50.3)
6.72	(170.5)	70	1.96	(49.8)
6.70	(170.0)	72	1.94	(49.3)
6.68	(169.5)	75	1.92	(48.8)
6.66	(169.0)	77	1.90	(48.3)
6.64	(168.5)	80	1.88	(47.8)
6.62	(168.0)	82	1.86	(47.2)
6.60	(167.5)	85	1.84	(46.7)
6.58	(167.0)	87	1.82	(46.2)
6.56	(166.5)	90	1.80	(45.7)
6.54	(166.0)	92	1.78	(45.2)
6.52	(165.5)	95	1.76	(44.7)
6.50	(165.0)	97	1.74	(44.2)
6.48	(164.5)	100	1.72	(43.7)
6.46	(164.0)	102	1.70	(43.2)
6.44	(163.5)	105	1.68	(42.7)
6.42	(163.0)	107	1.66	(42.2)
6.40	(162.5)	110	1.64	(41.7)
6.38	(162.0)	112	1.62	(41.1)
6.36	(161.5)	115	1.60	(40.6)
6.34	(161.0)	117	1.58	(40.1)
6.32	(160.5)	120	1.56	(39.6)

1 Wear Chart: 183

2 If 9W-5265 & 66, 7T-0715 & 16, or 320-3053 & 54 link cracking has been experienced, please use the Lesser Allowable Wear chart located on, page 278 at the end of the Elevated Sprocket Machine Section. Also see, page 88 for further definition of Link Allowable Wear.

# D10N, D10R, D10T — 10.25 in. (260.4 mm)

## Bushings <sup>(1)</sup> Sealed & Lubricated Track

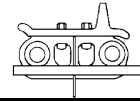
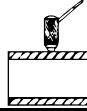

Caliper		Allowable Wear		Ultrasonic		Depth Gauge	
Inches	(mm)	Lesser % Worn	Greater % Worn	Inches	(mm)	Inches	(mm)
3.74	(95.0)	0	0	0.72	(18.3)	4.86	(123.5)
3.72	(94.5)	10	8	0.70	(17.8)	4.84	(123.0)
3.70	(94.0)	20	16	0.68	(17.3)	4.82	(122.5)
3.68	(93.5)	30	24	0.66	(16.8)	4.80	(122.0)
3.66	(93.0)	40	32	0.64	(16.3)	4.78	(121.5)
3.64	(92.5)	50	40	0.62	(15.7)	4.76	(121.0)
3.62	(91.9)	60	48	0.60	(15.2)	4.74	(120.5)
3.60	(91.4)	70	52	0.58	(14.7)	4.72	(119.9)
3.58	(90.9)	76	56	0.56	(14.2)	4.70	(119.4)
3.56	(90.4)	80	60	0.54	(13.7)	4.68	(118.9)
3.54	(89.9)	84	64	0.52	(13.2)	4.66	(118.4)
3.52	(89.4)	88	68	0.50	(12.7)	4.64	(117.9)
3.50	(88.9)	92	72	0.48	(12.2)	4.62	(117.4)
3.48	(88.4)	96	76	0.46	(11.7)	4.60	(116.9)
3.46	(87.9)	100	80	0.44	(11.2)	4.58	(116.4)
3.44	(87.4)	104	84	0.42	(10.7)	4.56	(115.9)
3.42	(86.9)	108	88	0.40	(10.2)	4.54	(115.4)
3.40	(86.4)	112	92	0.38	(9.7)	4.52	(114.9)
3.38	(85.9)	116	96	0.36	(9.1)	4.50	(114.4)
3.36	(85.3)	120	100	0.34	(8.6)	4.48	(113.8)
3.34	(84.8)		104	0.32	(8.1)	4.46	(113.3)
3.32	(84.3)		108	0.30	(7.6)	4.44	(112.8)
3.30	(83.8)		112	0.28	(7.1)	4.42	(112.3)
3.28	(83.3)		116	0.26	(6.6)	4.40	(111.8)
3.26	(82.8)		120	0.24	(6.1)	4.38	(111.3)

**Note: Do Not Use Depth Gauge Until Bushings Have Been "Turned."**



# D10N, D10R, D10T — 10.25 in. (260.4 mm)

## Track Shoes <sup>(1)</sup> Super Extreme Service

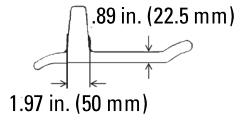
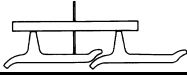

Depth Gauge		High Impact	Low/Moderate	Ultrasonic	
Inches	(mm)	% Worn	Impact % Worn	Inches	(mm)
4.00	(101.5)	0	0	4.85	(123.2)
3.90	(99.0)	4	4	4.75	(120.7)
3.80	(96.5)	8	8	4.65	(118.1)
3.70	(94.0)	12	12	4.55	(115.6)
3.60	(91.5)	16	16	4.45	(113.0)
3.50	(89.0)	20	20	4.35	(110.5)
3.40	(86.5)	24	24	4.25	(108.0)
3.30	(84.0)	28	28	4.15	(105.4)
3.20	(81.5)	32	32	4.05	(102.9)
3.10	(78.5)	36	36	3.95	(100.3)
3.00	(76.0)	40	40	3.85	(97.8)
2.90	(73.5)	44	43	3.75	(95.3)
2.80	(71.0)	48	46	3.65	(92.7)
2.70	(68.5)	52	49	3.55	(90.2)
2.60	(66.0)	56	52	3.45	(87.6)
2.50	(63.5)	60	55	3.35	(85.1)
2.40	(61.0)	64	58	3.25	(82.6)
2.30	(58.5)	68	61	3.15	(80.0)
2.20	(56.0)	72	64	3.05	(77.5)
2.10	(53.5)	76	67	2.95	(74.9)
2.00	(51.0)	80	70	2.85	(72.4)
1.90	(48.5)	84	73	2.75	(69.9)
1.80	(45.5)	88	76	2.65	(67.3)
1.70	(43.0)	92	79	2.55	(64.8)
1.60	(40.5)	96	82	2.45	(62.2)
1.50	(38.0)	100	85	2.35	(59.7)
1.40	(35.5)	104	88	2.25	(57.2)
1.30	(33.0)	108	91	2.15	(54.6)
1.20	(30.5)	112	94	2.05	(52.1)
1.10	(28.0)	116	97	1.95	(49.5)
1.00	(25.5)	120	100	1.85	(47.0)
0.90	(23.0)		103	1.75	(44.5)
0.80	(20.5)		106	1.65	(41.9)
0.70	(18.0)		109	1.55	(39.4)
0.60	(15.0)		112	1.45	(36.8)
0.50	(12.5)		115	1.35	(34.3)
0.40	(10.0)		118	1.25	(31.8)
0.30	(7.5)		121	1.15	(29.2)

# D10N, D10R, D10T — 10.25 in. (260.4 mm)

## Track Shoes <sup>(1)</sup> Extreme Service

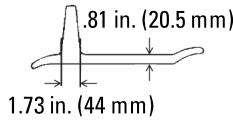
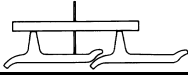

Depth Gauge		High Impact	Low/Moderate	Ultrasonic	
Inches	(mm)	% Worn	Impact % Worn	Inches	(mm)
3.70	(94.0)	0	0	4.50	(114.3)
3.60	(91.5)	5	4	4.40	(111.8)
3.50	(89.0)	10	8	4.30	(109.2)
3.40	(86.5)	15	12	4.20	(106.7)
3.30	(84.0)	20	16	4.10	(104.1)
3.20	(81.5)	25	20	4.00	(101.6)
3.10	(78.5)	30	24	3.90	(99.1)
3.00	(76.0)	35	28	3.80	(96.5)
2.90	(73.5)	40	32	3.70	(94.0)
2.80	(71.0)	45	36	3.60	(91.4)
2.70	(68.5)	50	40	3.50	(88.9)
2.60	(66.0)	55	44	3.40	(86.4)
2.50	(63.5)	60	48	3.30	(83.8)
2.40	(61.0)	64	52	3.20	(81.3)
2.30	(58.5)	68	56	3.10	(78.7)
2.20	(56.0)	72	60	3.00	(76.2)
2.10	(53.5)	76	64	2.90	(73.7)
2.00	(51.0)	80	68	2.80	(71.1)
1.90	(48.5)	84	72	2.70	(68.6)
1.80	(45.5)	88	76	2.60	(66.0)
1.70	(43.0)	92	79	2.50	(63.5)
1.60	(40.5)	96	82	2.40	(61.0)
1.50	(38.0)	100	85	2.30	(58.4)
1.40	(35.5)	104	88	2.20	(55.9)
1.30	(33.0)	108	91	2.10	(53.3)
1.20	(30.5)	112	94	2.00	(50.8)
1.10	(28.0)	116	97	1.90	(48.3)
1.00	(25.5)	120	100	1.80	(45.7)
0.90	(23.0)		103	1.70	(43.2)
0.80	(20.5)		106	1.60	(40.6)
0.70	(18.0)		109	1.50	(38.1)
0.60	(15.0)		112	1.40	(35.6)
0.50	(12.5)		115	1.30	(33.0)
0.40	(10.0)		118	1.20	(30.5)
0.30	(7.5)		121	1.10	(27.9)

## D10N, D10R, D10T — 10.25 in. (260.4 mm)

**Idlers <sup>(1) (2) (3)</sup>**  
**Conventional Idler**

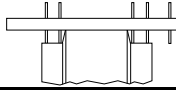

**Depth Gauge**

Inches	(mm)	% Worn
0.78	(20.0)	0
0.82	(21.0)	8
0.86	(22.0)	16
0.90	(23.0)	24
0.94	(24.0)	32
0.98	(25.0)	40
1.02	(26.0)	48
1.06	(27.0)	56
1.10	(28.0)	64
1.14	(29.0)	72
1.18	(30.0)	76
1.22	(31.0)	80
1.26	(32.0)	84
1.30	(33.0)	88
1.34	(34.0)	92
1.38	(35.0)	96
1.42	(36.0)	100
1.46	(37.0)	104
1.50	(38.0)	108
1.54	(39.0)	112
1.58	(40.0)	116
1.62	(41.0)	120

- 1 Flange width is 5.24 in. (133 mm)
- 2 New tread diameter is 30.16 in. (766 mm)
- 3 Wear Chart: 4484

# D10N, D10R, D10T — 10.25 in. (260.4 mm)

Idlers <sup>(1)</sup> <sup>(2)</sup> <sup>(3)</sup>  
 Use with Sound Reduction Idler only

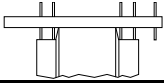

Depth Gauge

Inches	(mm)	% Worn
1.10	(28.0)	0
1.12	(28.5)	4
1.14	(29.0)	8
1.16	(29.5)	12
1.18	(30.0)	16
1.20	(30.5)	20
1.22	(31.0)	24
1.24	(31.5)	28
1.26	(32.0)	32
1.28	(32.5)	36
1.30	(33.0)	40
1.32	(33.5)	44
1.34	(34.0)	48
1.36	(34.5)	52
1.38	(35.0)	55
1.40	(35.5)	58
1.42	(36.0)	61
1.44	(36.5)	64
1.46	(37.0)	67
1.48	(37.5)	70
1.50	(38.0)	73
1.52	(38.5)	76
1.54	(39.0)	79
1.56	(39.5)	82
1.58	(40.0)	85
1.60	(40.5)	88
1.62	(41.0)	91
1.64	(41.5)	94
1.66	(42.0)	97
1.68	(42.5)	100
1.70	(43.0)	103
1.72	(43.5)	106
1.74	(44.0)	109
1.76	(44.5)	112
1.78	(45.0)	115
1.80	(45.5)	118
1.82	(46.0)	121
1.84	(46.5)	124



Ultrasonic

Center Flange Wear

Inches	(mm)	Inches	(mm)
1.56	(39.6)	0.00	(0.0)
1.54	(39.1)	0.02	(0.5)
1.52	(38.6)	0.04	(1.0)
1.50	(38.1)	0.06	(1.5)
1.48	(37.6)	0.08	(2.0)
1.46	(37.1)	0.10	(2.5)
1.44	(36.6)	0.12	(3.0)
1.42	(36.1)	0.14	(3.5)
1.40	(35.6)	0.16	(4.0)
1.38	(35.1)	0.18	(4.5)
1.36	(34.5)	0.20	(5.0)
1.34	(34.0)	0.22	(5.5)
1.32	(33.5)	0.24	(6.0)
1.30	(33.0)	0.26	(6.5)
1.28	(32.5)	0.28	(7.0)
1.26	(32.0)	0.30	(7.5)
1.24	(31.5)	0.32	(8.0)
1.22	(31.0)	0.34	(8.5)
1.20	(30.5)	0.36	(9.0)
1.18	(30.0)	0.38	(9.5)
1.16	(29.5)	0.40	(10.0)
1.14	(29.0)	0.42	(10.5)
1.12	(28.4)	0.44	(11.0)
1.10	(27.9)	0.46	(11.5)

**NOTE**

Ultrasonic measurement is to determine flange wear only.

- 1 Flange width is 5.21 in. (132.4 mm)
- 2 New Tread diameter is 29.54 in. (750.2 mm)
- 3 Wear Chart: 4488

# D10N, D10R, D10T — 10.25 in. (260.4 mm)

## Track Rollers <sup>(1) (2)</sup> Single Flange

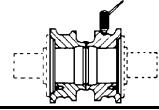
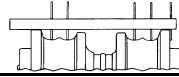
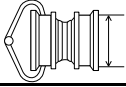

Caliper		% Worn	Depth Gauge		Ultrasonic	
Inches	(mm)		Inches	(mm)	Inches	(mm)
10.94	(278.0)	0	0.67	(17.0)	2.85	(72.4)
10.84	(275.5)	5	0.72	(18.5)	2.80	(71.1)
10.74	(273.0)	10	0.77	(19.5)	2.75	(69.9)
10.64	(270.5)	15	0.82	(21.0)	2.70	(68.6)
10.54	(267.5)	20	0.87	(22.0)	2.65	(67.3)
10.44	(265.0)	25	0.92	(23.5)	2.60	(66.0)
10.34	(262.5)	30	0.97	(24.5)	2.55	(64.8)
10.24	(260.0)	35	1.02	(26.0)	2.50	(63.5)
10.14	(257.5)	40	1.07	(27.0)	2.45	(62.2)
10.04	(255.0)	43	1.12	(28.5)	2.40	(61.0)
9.94	(252.5)	46	1.17	(29.5)	2.35	(59.7)
9.84	(250.0)	49	1.22	(31.0)	2.30	(58.4)
9.74	(247.5)	52	1.27	(32.5)	2.25	(57.2)
9.64	(245.0)	55	1.32	(33.5)	2.20	(55.9)
9.54	(242.5)	58	1.37	(35.0)	2.15	(54.6)
9.44	(240.0)	61	1.42	(36.0)	2.10	(53.3)
9.34	(237.0)	64	1.47	(37.5)	2.05	(52.1)
9.24	(234.5)	67	1.52	(38.5)	2.00	(50.8)
9.14	(232.0)	70	1.57	(40.0)	1.95	(49.5)
9.04	(229.5)	73	1.62	(41.0)	1.90	(48.3)
8.94	(227.0)	76	1.67	(42.5)	1.85	(47.0)
8.84	(224.5)	79	1.72	(43.5)	1.80	(45.7)
8.74	(222.0)	82	1.77	(45.0)	1.75	(44.5)
8.64	(219.5)	85	1.82	(46.0)	1.70	(43.2)
8.54	(217.0)	88	1.87	(47.5)	1.65	(41.9)
8.44	(214.5)	91	1.92	(49.0)	1.60	(40.6)
8.34	(212.0)	94	1.97	(50.0)	1.55	(39.4)
8.24	(209.5)	97	2.02	(51.5)	1.50	(38.1)
8.14	(207.0)	100	2.07	(52.5)	1.45	(36.8)
8.04	(204.0)	103	2.12	(54.0)	1.40	(35.6)
7.94	(201.5)	106	2.17	(55.0)	1.35	(34.3)
7.84	(199.0)	109	2.22	(56.5)	1.30	(33.0)
7.74	(196.5)	112	2.27	(57.5)	1.25	(31.8)
7.64	(194.0)	115	2.32	(59.0)	1.20	(30.5)
7.54	(191.5)	118	2.37	(60.0)	1.15	(29.2)
7.44	(189.0)	121	2.42	(61.5)	1.10	(27.9)

1 Flange diameter is 12.28 in. (312 mm)

2 Wear Chart: 5385

# D10N, D10R, D10T — 10.25 in. (260.4 mm)

## Track Rollers <sup>(1) (2)</sup> Double Flange

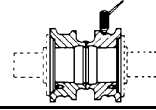
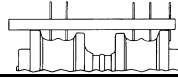
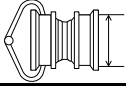

Caliper		% Worn	Depth Gauge		Ultrasonic	
Inches	(mm)		Inches	(mm)	Inches	(mm)
10.55	(268.0)	0	0.86	(22.0)	2.65	(67.3)
10.45	(265.5)	5	0.91	(23.0)	2.60	(66.0)
10.35	(263.0)	10	0.96	(24.5)	2.55	(64.8)
10.25	(260.5)	15	1.01	(25.5)	2.55	(63.5)
10.15	(258.0)	20	1.06	(27.0)	2.45	(62.2)
10.05	(255.5)	25	1.11	(28.0)	2.40	(61.0)
9.95	(252.5)	30	1.16	(29.5)	2.35	(59.7)
9.85	(250.0)	35	1.21	(30.5)	2.30	(58.4)
9.75	(247.5)	40	1.26	(32.0)	2.25	(57.2)
9.65	(245.0)	45	1.31	(33.5)	2.20	(55.9)
9.55	(242.5)	50	1.36	(34.5)	2.15	(54.6)
9.45	(240.0)	55	1.41	(36.0)	2.10	(53.3)
9.35	(237.5)	60	1.46	(37.0)	2.05	(52.1)
9.25	(235.0)	65	1.51	(38.5)	2.00	(50.8)
9.15	(232.5)	70	1.56	(39.5)	1.95	(49.5)
9.05	(230.0)	73	1.61	(41.0)	1.90	(48.3)
8.95	(227.5)	76	1.66	(42.0)	1.85	(47.0)
8.85	(225.0)	79	1.71	(43.5)	1.80	(45.7)
8.75	(222.5)	82	1.76	(44.5)	1.75	(44.5)
8.65	(219.5)	85	1.81	(46.0)	1.70	(43.2)
8.55	(217.0)	88	1.86	(47.0)	1.65	(41.9)
8.45	(214.5)	91	1.91	(48.5)	1.60	(40.6)
8.35	(212.0)	94	1.96	(50.0)	1.55	(39.4)
8.25	(209.5)	97	2.01	(51.0)	1.50	(38.1)
8.15	(207.0)	100	2.06	(52.5)	1.45	(36.8)
8.05	(204.5)	103	2.11	(53.5)	1.40	(35.6)
7.95	(202.0)	106	2.16	(55.0)	1.35	(34.3)
7.85	(199.5)	109	2.21	(56.0)	1.30	(33.0)
7.75	(197.0)	112	2.26	(57.5)	1.25	(31.8)
7.65	(194.5)	115	2.31	(58.5)	1.20	(30.5)
7.55	(192.0)	118	2.36	(60.0)	1.15	(29.2)
7.45	(189.0)	121	2.41	(61.0)	1.10	(27.9)

1 Flange diameter is 12.28 in. (312 mm)

2 Wear Chart: 6285

# D10N, D10R, D10T — 10.25 in. (260.4 mm)

## Sprockets <sup>(1)</sup> Not for use with Sound Reduction Sprocket



### Tape Measure

Inches	(mm)	% Worn
11.30	(287.0)	0
11.25	(286.0)	5
11.20	(284.5)	10
11.15	(283.0)	15
11.10	(282.0)	20
11.05	(280.5)	25
11.00	(279.5)	30
10.95	(278.0)	35
10.90	(277.0)	40
10.85	(275.5)	45
10.80	(274.5)	50
10.75	(273.0)	55
10.70	(272.0)	60
10.65	(270.5)	65
10.60	(269.0)	70
10.55	(268.0)	75
10.50	(266.5)	80
10.45	(265.5)	84
10.40	(264.0)	88
10.35	(263.0)	92
10.30	(261.5)	96
10.25	(260.5)	100
10.20	(259.0)	104
10.15	(258.0)	108
10.10	(256.5)	112
10.05	(255.5)	116
10.00	(254.0)	120

#### NOTE

Measure across 3 teeth

# D10N, D10R, D10T — 10.25 in. (260.4 mm)

## Sprockets <sup>(1)</sup> Sound Reduction Sprocket Only



### Tape Measure

Inches	(mm)	% Worn
11.15	(283.0)	0
11.10	(282.0)	6
11.05	(280.5)	12
11.00	(279.5)	18
10.95	(278.0)	24
10.90	(277.0)	30
10.85	(275.5)	36
10.80	(274.5)	42
10.75	(273.0)	48
10.70	(272.0)	54
10.65	(270.5)	60
10.60	(269.0)	65
10.55	(268.0)	70
10.50	(266.5)	75
10.45	(265.5)	80
10.40	(264.0)	85
10.35	(263.0)	90
10.30	(261.5)	95
10.25	(260.5)	100
10.20	(259.0)	105
10.15	(258.0)	110
10.10	(256.5)	115
10.05	(255.5)	120

1 Wear Chart: 7183



**Track Links <sup>(1)</sup>  
9W-5723 & 24  
9W-5933 & 34**



Depth Gauge		Allowable Wear Greater % <sup>(2)</sup> Worn	Ultrasonic	
Inches	(mm)		Inches	(mm)
7.12	(181.0)	0	1.92	(48.8)
7.10	(180.5)	4	1.90	(48.3)
7.08	(180.0)	8	1.88	(47.8)
7.06	(179.5)	12	1.86	(47.2)
7.04	(179.0)	16	1.84	(46.7)
7.02	(178.5)	20	1.82	(46.2)
7.00	(178.0)	24	1.80	(45.7)
6.98	(177.5)	28	1.78	(45.2)
6.96	(177.0)	32	1.76	(44.7)
6.94	(176.5)	36	1.74	(44.2)
6.92	(176.0)	40	1.72	(43.7)
6.90	(175.5)	44	1.70	(43.2)
6.88	(175.0)	48	1.68	(42.7)
6.86	(174.0)	52	1.66	(42.2)
6.84	(173.5)	55	1.64	(41.7)
6.82	(173.0)	57	1.62	(41.1)
6.80	(172.5)	60	1.60	(40.6)
6.78	(172.0)	62	1.58	(40.1)
6.76	(171.5)	65	1.56	(39.6)
6.74	(171.0)	67	1.54	(39.1)
6.72	(170.5)	70	1.52	(38.6)
6.70	(170.0)	72	1.50	(38.1)
6.68	(169.5)	75	1.48	(37.6)
6.66	(169.0)	77	1.46	(37.1)
6.64	(168.5)	80	1.44	(36.6)
6.62	(168.0)	82	1.42	(36.1)
6.60	(167.5)	85	1.40	(35.6)
6.58	(167.0)	87	1.38	(35.1)
6.56	(166.5)	90	1.36	(34.5)
6.54	(166.0)	92	1.34	(34.0)
6.52	(165.5)	95	1.32	(33.5)
6.50	(165.0)	97	1.30	(33.0)
6.48	(164.5)	100	1.28	(32.5)
6.46	(164.0)	102	1.26	(32.0)
6.44	(163.5)	105	1.24	(31.5)
6.42	(163.0)	107	1.22	(31.0)
6.40	(162.5)	110	1.20	(30.5)
6.38	(162.0)	112	1.18	(30.0)
6.36	(161.5)	115	1.16	(29.5)
6.34	(161.0)	117	1.14	(29.0)
6.32	(160.5)	120	1.12	(28.4)

1 Wear Chart: 182

2 If 9W-5723 & 24, 9W-5933 & 34 link cracking has been experienced, please use the Lesser Allowable Wear chart located on, page 279 at the end of the Elevated Sprocket Machine Section. Also see, page 88 for further definition of Link Allowable Wear.

# D10 - 10.25 in. (260.4 mm)

## Bushings <sup>(1)</sup> Sealed & Lubricated Track

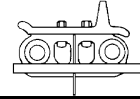
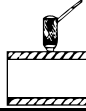

Caliper		Allowable Wear		Ultrasonic		Depth Gauge	
Inches	(mm)	Lesser % Worn	Greater % Worn	Inches	(mm)	Inches	(mm)
3.81	(96.8)	0	0	0.76	(19.3)	5.21	(132.4)
3.79	(96.3)	10	8	0.74	(18.8)	5.19	(131.9)
3.77	(95.8)	20	16	0.72	(18.3)	5.17	(131.4)
3.75	(95.3)	30	24	0.70	(17.8)	5.15	(130.9)
3.73	(94.7)	40	32	0.68	(17.3)	5.13	(130.3)
3.71	(94.2)	50	40	0.66	(16.8)	5.11	(129.8)
3.69	(93.7)	60	44	0.64	(16.3)	5.09	(129.3)
3.67	(93.2)	68	48	0.62	(15.7)	5.07	(128.8)
3.65	(92.7)	72	52	0.60	(15.2)	5.05	(128.3)
3.63	(92.2)	76	56	0.58	(14.7)	5.03	(127.8)
3.61	(91.7)	80	60	0.56	(14.2)	5.01	(127.3)
3.59	(91.2)	84	64	0.54	(13.7)	4.99	(126.8)
3.57	(90.7)	88	68	0.52	(13.2)	4.97	(126.3)
3.55	(90.2)	92	72	0.50	(12.7)	4.95	(125.8)
3.53	(89.7)	96	76	0.48	(12.2)	4.93	(125.3)
3.51	(89.2)	100	80	0.46	(11.7)	4.91	(124.8)
3.49	(88.6)	104	84	0.44	(11.2)	4.89	(124.2)
3.47	(88.1)	108	88	0.42	(10.7)	4.87	(123.7)
3.45	(87.6)	112	92	0.40	(10.2)	4.85	(123.2)
3.43	(87.1)	116	96	0.38	(9.7)	4.83	(122.7)
3.41	(86.6)	120	100	0.36	(9.1)	4.81	(122.2)
3.39	(86.1)		104	0.34	(8.6)	4.79	(121.7)
3.37	(85.6)		108	0.32	(8.1)	4.77	(121.2)
3.35	(85.1)		112	0.30	(7.6)	4.75	(120.7)
3.33	(84.6)		116	0.28	(7.1)	4.73	(120.2)
3.31	(84.1)		120	0.26	(6.6)	4.71	(119.7)

**Note: Do Not Use Depth Gauge Until Bushings Have Been "Turned."**

**Track Shoes <sup>(1)</sup>  
Extreme Service**

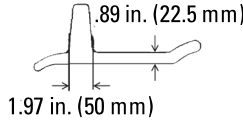
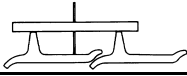

Depth Gauge		High Impact	Low/Moderate	Ultrasonic	
Inches	(mm)	% Worn	Impact % Worn	Inches	(mm)
4.00	(101.5)	0	0	4.85	(123.2)
3.90	(99.0)	4	4	4.75	(120.7)
3.80	(96.5)	8	8	4.65	(118.1)
3.70	(94.0)	12	12	4.55	(115.6)
3.60	(91.5)	16	16	4.45	(113.0)
3.50	(89.0)	20	20	4.35	(110.5)
3.40	(86.5)	24	24	4.25	(108.0)
3.30	(84.0)	28	28	4.15	(105.4)
3.20	(81.5)	32	32	4.05	(102.9)
3.10	(78.5)	36	36	3.95	(100.3)
3.00	(76.0)	40	40	3.85	(97.8)
2.90	(73.5)	44	43	3.75	(95.3)
2.80	(71.0)	48	46	3.65	(92.7)
2.70	(68.5)	52	49	3.55	(90.2)
2.60	(66.0)	56	52	3.45	(87.6)
2.50	(63.5)	60	55	3.35	(85.1)
2.40	(61.0)	64	58	3.25	(82.6)
2.30	(58.5)	68	61	3.15	(80.0)
2.20	(56.0)	72	64	3.05	(77.5)
2.10	(53.5)	76	67	2.95	(74.9)
2.00	(51.0)	80	70	2.85	(72.4)
1.90	(48.5)	84	73	2.75	(69.9)
1.80	(45.5)	88	76	2.65	(67.3)
1.70	(43.0)	92	79	2.55	(64.8)
1.60	(40.5)	96	82	2.45	(62.2)
1.50	(38.0)	100	85	2.35	(59.7)
1.40	(35.5)	104	88	2.25	(57.2)
1.30	(33.0)	108	91	2.15	(54.6)
1.20	(30.5)	112	94	2.05	(52.1)
1.10	(28.0)	116	97	1.95	(49.5)
1.00	(25.5)	120	100	1.85	(47.0)
0.90	(23.0)		103	1.75	(44.5)
0.80	(20.5)		106	1.65	(41.9)
0.70	(18.0)		109	1.55	(39.4)
0.60	(15.0)		112	1.45	(36.8)
0.50	(12.5)		115	1.35	(34.3)
0.40	(10.0)		118	1.25	(31.8)
0.30	(7.5)		121	1.15	(29.2)

# D10 - 10.25 in. (260.4 mm)

## Track Shoes <sup>(1)</sup> Moderate Service

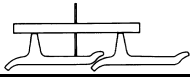

Depth Gauge		High Impact	Low/Moderate	Ultrasonic	
Inches	(mm)	% Worn	Impact % Worn	Inches	(mm)
3.70	(94.0)	0	0	4.50	(114.3)
3.60	(91.5)	5	4	4.40	(111.8)
3.50	(89.0)	10	8	4.30	(109.2)
3.40	(86.5)	15	12	4.20	(106.7)
3.30	(84.0)	20	16	4.10	(104.1)
3.20	(81.5)	25	20	4.00	(101.6)
3.10	(78.5)	30	24	3.90	(99.1)
3.00	(76.0)	35	28	3.80	(96.5)
2.90	(73.5)	40	32	3.70	(94.0)
2.80	(71.0)	45	36	3.60	(91.4)
2.70	(68.5)	50	40	3.50	(88.9)
2.60	(66.0)	55	44	3.40	(86.4)
2.50	(63.5)	60	48	3.30	(83.8)
2.40	(61.0)	64	52	3.20	(81.3)
2.30	(58.5)	68	56	3.10	(78.7)
2.20	(56.0)	72	60	3.00	(76.2)
2.10	(53.5)	76	64	2.90	(73.7)
2.00	(51.0)	80	68	2.80	(71.1)
1.90	(48.5)	84	72	2.70	(68.6)
1.80	(45.5)	88	76	2.60	(66.0)
1.70	(43.0)	92	79	2.50	(63.5)
1.60	(40.5)	96	82	2.40	(61.0)
1.50	(38.0)	100	85	2.30	(58.4)
1.40	(35.5)	104	88	2.20	(55.9)
1.30	(33.0)	108	91	2.10	(53.3)
1.20	(30.5)	112	94	2.00	(50.8)
1.10	(28.0)	116	97	1.90	(48.3)
1.00	(25.5)	120	100	1.80	(45.7)
0.90	(23.0)		103	1.70	(43.2)
0.80	(20.5)		106	1.60	(40.6)
0.70	(18.0)		109	1.50	(38.1)
0.60	(15.0)		112	1.40	(35.6)
0.50	(12.5)		115	1.30	(33.0)
0.40	(10.0)		118	1.20	(30.5)
0.30	(7.5)		121	1.10	(27.9)

**Idlers** (1) (2) (3)

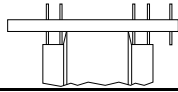

**Depth Gauge**

<b>Inches</b>	<b>(mm)</b>	<b>% Worn</b>
0.78	(20.0)	0
0.82	(21.0)	10
0.86	(22.0)	20
0.90	(23.0)	30
0.94	(24.0)	40
0.98	(25.0)	50
1.02	(26.0)	56
1.06	(27.0)	60
1.10	(28.0)	64
1.14	(29.0)	68
1.18	(30.0)	72
1.22	(31.0)	76
1.26	(32.0)	80
1.30	(33.0)	84
1.34	(34.0)	88
1.38	(35.0)	92
1.42	(36.0)	96
1.46	(37.0)	100
1.50	(38.0)	104
1.54	(39.0)	108
1.58	(40.0)	112
1.62	(41.0)	116
1.66	(42.0)	120

- 1 Flange width is 5.04 in (128 mm)
- 2 New tread diameter is 34.02 in. (864 mm)
- 3 Wear Chart: 4483

# D10 - 10.25 in. (260.4 mm)

## Track Rollers <sup>(1) (2)</sup> Single Flange

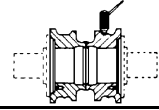
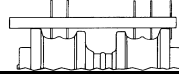

Caliper		% Worn	Depth Gauge		Ultrasonic	
Inches	(mm)		Inches	(mm)	Inches	(mm)
11.30	(287.0)	0	0.53	(13.5)	2.83	(71.9)
11.22	(285.0)	5	0.57	(14.5)	2.79	(70.9)
11.14	(283.0)	10	0.61	(15.5)	2.75	(69.9)
11.06	(281.0)	15	0.65	(16.5)	2.71	(68.8)
10.98	(279.0)	20	0.69	(17.5)	2.67	(67.8)
10.90	(277.0)	25	0.73	(18.5)	2.63	(66.8)
10.82	(275.0)	30	0.77	(19.5)	2.59	(65.8)
10.74	(273.0)	35	0.81	(20.5)	2.55	(64.8)
10.66	(271.0)	40	0.85	(21.5)	2.51	(63.8)
10.58	(268.5)	45	0.89	(22.5)	2.47	(62.7)
10.50	(266.5)	50	0.93	(23.5)	2.43	(61.7)
10.42	(264.5)	55	0.97	(24.5)	2.39	(60.7)
10.34	(262.5)	58	1.01	(25.5)	2.35	(59.7)
10.26	(260.5)	61	1.05	(26.5)	2.31	(58.7)
10.18	(258.5)	64	1.09	(27.5)	2.27	(57.7)
10.10	(256.5)	67	1.13	(28.5)	2.23	(56.6)
10.02	(254.5)	70	1.17	(29.5)	2.19	(55.6)
9.94	(252.5)	73	1.21	(30.5)	2.15	(54.6)
9.86	(250.5)	76	1.25	(32.0)	2.11	(53.6)
9.78	(248.5)	79	1.29	(33.0)	2.07	(52.6)
9.70	(246.5)	82	1.33	(34.0)	2.03	(51.6)
9.62	(244.5)	85	1.37	(35.0)	1.99	(50.5)
9.54	(242.5)	88	1.41	(36.0)	1.95	(49.5)
9.46	(240.5)	91	1.45	(37.0)	1.91	(48.5)
9.38	(238.5)	94	1.49	(38.0)	1.87	(47.5)
9.30	(236.0)	97	1.53	(39.0)	1.83	(46.5)
9.22	(234.0)	100	1.57	(40.0)	1.79	(45.5)
9.14	(232.0)	103	1.61	(41.0)	1.75	(44.4)
9.06	(232.0)	106	1.65	(42.0)	1.71	(43.4)
8.98	(228.0)	109	1.69	(43.0)	1.67	(42.4)
8.90	(226.0)	112	1.73	(44.0)	1.63	(41.4)
8.82	(224.0)	115	1.77	(45.0)	1.59	(40.4)
8.74	(222.0)	118	1.81	(46.0)	1.55	(39.4)
8.66	(222.0)	121	1.85	(47.0)	1.51	(38.4)

1 Flange diameter is 12.36 in. (314 mm)

2 Wear Chart: 5384

Track Rollers <sup>(1) (2)</sup>  
Double Flange

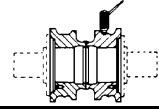
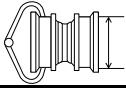

Caliper		% Worn	Depth Gauge		Ultrasonic	
Inches	(mm)		Inches	(mm)	Inches	(mm)
10.90	(277.0)	0	0.73	(18.5)	2.64	(67.1)
10.82	(275.0)	6	0.77	(19.5)	2.60	(66.0)
10.74	(273.0)	12	0.81	(20.5)	2.56	(65.0)
10.66	(271.0)	18	0.85	(21.5)	2.52	(64.0)
10.58	(268.5)	24	0.89	(22.5)	2.48	(63.0)
10.50	(266.5)	30	0.93	(23.5)	2.44	(62.0)
10.42	(264.5)	36	0.97	(24.5)	2.40	(61.0)
10.34	(262.5)	42	1.01	(25.5)	2.36	(59.9)
10.26	(260.5)	48	1.05	(26.5)	2.32	(58.9)
10.18	(258.5)	52	1.09	(27.5)	2.28	(57.9)
10.10	(256.5)	56	1.13	(28.5)	2.24	(56.9)
10.02	(254.5)	60	1.17	(29.5)	2.20	(55.9)
9.94	(252.5)	64	1.21	(30.5)	2.16	(54.9)
9.86	(250.5)	68	1.25	(32.0)	2.12	(53.8)
9.78	(248.5)	72	1.29	(33.0)	2.08	(52.8)
9.70	(246.5)	76	1.33	(34.0)	2.04	(51.8)
9.62	(244.5)	80	1.37	(35.0)	2.00	(50.8)
9.54	(242.5)	84	1.41	(36.0)	1.96	(49.8)
9.46	(240.5)	88	1.45	(37.0)	1.92	(48.8)
9.38	(238.5)	92	1.49	(38.0)	1.88	(47.8)
9.30	(236.0)	96	1.53	(39.0)	1.84	(46.7)
9.22	(234.0)	100	1.57	(40.0)	1.80	(45.7)
9.14	(232.0)	104	1.61	(41.0)	1.76	(44.7)
9.06	(230.0)	108	1.65	(42.0)	1.72	(43.7)
8.98	(228.0)	112	1.69	(43.0)	1.68	(42.7)
8.90	(226.0)	116	1.73	(44.0)	1.64	(41.7)
8.82	(224.0)	120	1.77	(45.0)	1.60	(40.6)

1 Flange diameter is 12.36 in. (314 mm)  
2 Wear Chart: 5383

# D10 - 10.25 in. (260.4 mm)

## Sprockets <sup>(1)</sup>



Tape Measure		
Inches	(mm)	% Worn
11.05	(280.5)	0
11.00	(279.5)	7
10.95	(278.0)	14
10.90	(277.0)	21
10.85	(275.5)	28
10.80	(274.5)	34
10.75	(273.0)	40
10.70	(272.0)	46
10.65	(270.5)	52
10.60	(269.0)	58
10.55	(268.0)	64
10.50	(266.5)	70
10.45	(265.5)	76
10.40	(264.0)	82
10.35	(263.0)	88
10.30	(261.5)	94
10.25	(260.5)	100
10.20	(259.0)	106
10.15	(258.0)	112
10.10	(256.5)	118
10.05	(255.5)	124

### NOTE

Measure across 3 teeth



# D11N, D11R, D11T - 12.50 in. (317.5 mm)

## Track Links <sup>(1)</sup> 200-6325 & 26 Optional Tall Link

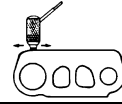
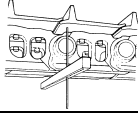

Depth Gauge			Ultrasonic	
Inches	(mm)	% Worn	Inches	(mm)
8.07	(205.0)	0	2.51	(63.8)
8.03	(204.0)	5	2.47	(62.7)
7.99	(203.0)	10	2.43	(61.7)
7.95	(202.0)	15	2.39	(60.7)
7.91	(201.0)	20	2.35	(59.7)
7.87	(200.0)	25	2.31	(58.7)
7.83	(199.0)	30	2.27	(57.7)
7.79	(198.0)	35	2.23	(56.6)
7.75	(197.0)	40	2.19	(55.6)
7.71	(196.0)	45	2.15	(54.6)
7.67	(195.0)	50	2.11	(53.6)
7.63	(194.0)	55	2.07	(52.6)
7.59	(193.0)	60	2.03	(51.6)
7.55	(192.0)	64	1.99	(50.5)
7.51	(191.0)	68	1.95	(49.5)
7.47	(189.5)	72	1.91	(48.5)
7.43	(188.5)	76	1.87	(47.5)
7.39	(187.5)	80	1.83	(46.5)
7.35	(186.5)	84	1.79	(45.5)
7.31	(185.5)	88	1.75	(44.5)
7.27	(184.5)	92	1.71	(43.4)
7.23	(183.5)	96	1.67	(42.4)
7.19	(182.5)	100	1.63	(41.4)
7.15	(181.5)	104	1.59	(40.4)
7.11	(180.5)	108	1.55	(39.4)
7.07	(179.5)	112	1.51	(38.4)
7.03	(178.5)	116	1.47	(37.3)
6.99	(177.5)	120	1.43	(36.3)

# D11N, D11R, D11T - 12.50 in. (317.5 mm)

**Track Links <sup>(1)</sup>**  
**6T-8049 & 50**  
**320-3541 & 42**  
**Standard Link or Scallop Resistant Link**

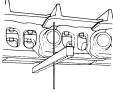

Depth Gauge		Allowable Wear Greater % <sup>(2)</sup> Worn	Ultrasonic	
Inches	(mm)		Inches	(mm)
7.79	(198.0)	0	2.24	(56.9)
7.77	(197.5)	4	2.22	(56.4)
7.75	(197.0)	8	2.20	(55.9)
7.73	(196.5)	12	2.18	(55.4)
7.71	(196.0)	16	2.16	(54.9)
7.69	(195.5)	20	2.14	(54.4)
7.67	(195.0)	24	2.12	(53.8)
7.65	(194.5)	28	2.10	(53.3)
7.63	(194.0)	32	2.08	(52.8)
7.61	(193.5)	36	2.06	(52.3)
7.59	(193.0)	40	2.04	(51.8)
7.57	(192.5)	44	2.02	(51.3)
7.55	(192.0)	48	2.00	(50.8)
7.53	(191.5)	52	1.98	(50.3)
7.51	(191.0)	55	1.96	(49.8)
7.49	(190.0)	57	1.94	(49.3)
7.47	(189.5)	60	1.92	(48.8)
7.45	(189.0)	62	1.90	(48.3)
7.43	(188.5)	65	1.88	(47.8)
7.41	(188.0)	67	1.86	(47.2)
7.39	(187.5)	70	1.84	(46.7)
7.37	(187.0)	72	1.82	(46.2)
7.35	(186.5)	75	1.80	(45.7)
7.33	(186.0)	77	1.78	(45.2)
7.31	(185.5)	80	1.76	(44.7)
7.29	(185.0)	82	1.74	(44.2)
7.27	(184.5)	85	1.72	(43.7)
7.25	(184.0)	87	1.70	(43.2)
7.23	(183.5)	90	1.68	(42.7)
7.21	(183.0)	92	1.66	(42.2)
7.19	(182.5)	95	1.64	(41.7)
7.17	(182.0)	97	1.62	(41.1)
7.15	(181.5)	100	1.60	(40.6)
7.13	(181.0)	102	1.58	(40.1)
7.11	(180.5)	105	1.56	(39.6)
7.09	(180.0)	107	1.54	(39.1)
7.07	(179.5)	110	1.52	(38.6)
7.05	(179.0)	112	1.50	(38.1)
7.03	(178.5)	115	1.48	(37.6)
7.01	(178.0)	117	1.46	(37.1)
6.99	(177.5)	120	1.44	(36.6)

1 Wear Chart: 200

2 If 6T-8049 & 50 link cracking has been experienced, please use the Lesser Allowable Wear chart located [on, page 280](#) at the end of the Elevated Sprocket Machine Section. Also [see, page 88](#) for further definition of Link Allowable Wear.

# D11N, D11R, D11T - 12.50 in. (317.5 mm)

## Bushings <sup>(1)</sup> Sealed & Lubricated Track

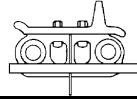
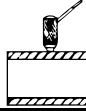

Caliper		Allowable Wear		Ultrasonic		Depth Gauge	
Inches	(mm)	Lesser % Worn	Greater % Worn	Inches	(mm)	Inches	(mm)
4.32	(109.7)	0	0	0.82	(20.8)	5.62	(142.7)
4.30	(109.2)	8	6	0.80	(20.3)	5.60	(142.2)
4.28	(108.7)	16	12	0.78	(19.8)	5.58	(141.7)
4.26	(108.2)	24	18	0.76	(19.3)	5.56	(141.2)
4.24	(107.7)	32	24	0.74	(18.8)	5.54	(140.7)
4.22	(107.2)	40	30	0.72	(18.3)	5.52	(140.2)
4.20	(106.7)	46	36	0.70	(17.8)	5.50	(139.7)
4.18	(106.2)	52	42	0.68	(17.3)	5.48	(139.2)
4.16	(105.7)	58	48	0.66	(16.8)	5.46	(138.7)
4.14	(105.2)	64	54	0.64	(16.3)	5.44	(138.2)
4.12	(104.6)	70	60	0.62	(15.7)	5.42	(137.7)
4.10	(104.1)	76	64	0.60	(15.2)	5.40	(137.2)
4.08	(103.6)	82	68	0.58	(14.7)	5.38	(136.7)
4.06	(103.1)	88	72	0.56	(14.2)	5.36	(136.1)
4.04	(102.6)	94	76	0.54	(13.7)	5.34	(135.6)
4.02	(102.1)	100	80	0.52	(13.2)	5.32	(135.1)
4.00	(101.6)	106	84	0.50	(12.7)	5.30	(134.6)
3.98	(101.1)	112	88	0.48	(12.2)	5.28	(134.1)
3.96	(100.6)	118	92	0.46	(11.7)	5.26	(133.6)
3.94	(100.1)	124	96	0.44	(11.2)	5.24	(133.1)
3.92	(99.6)		100	0.42	(10.7)	5.22	(132.6)
3.90	(99.1)		104	0.40	(10.2)	5.20	(132.1)
3.88	(98.6)		108	0.38	(9.7)	5.18	(131.6)
3.86	(98.0)		112	0.36	(9.1)	5.16	(131.1)
3.84	(97.5)		116	0.34	(8.6)	5.14	(130.6)
3.82	(97.0)		120	0.32	(8.1)	5.12	(130.0)

**Note: Do Not Use Depth Gauge Until Bushings Have Been "Turned."**

# D11N, D11R, D11T - 12.50 in. (317.5 mm)

## Track Shoes <sup>(1)</sup> Extreme Service

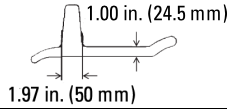
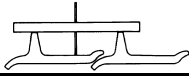

Depth Gauge		High Impact	Low/Moderate	Ultrasonic	
Inches	(mm)	% Worn	Impact % Worn	Inches	(mm)
4.00	(101.5)	0	0	4.95	(125.7)
3.90	(99.0)	4	4	4.85	(123.2)
3.80	(96.5)	8	8	4.75	(120.7)
3.70	(94.0)	12	12	4.65	(118.1)
3.60	(91.5)	16	16	4.55	(115.6)
3.50	(89.0)	20	20	4.45	(113.0)
3.40	(86.5)	24	24	4.35	(110.5)
3.30	(84.0)	28	28	4.25	(108.0)
3.20	(81.5)	32	32	4.15	(105.4)
3.10	(78.5)	36	36	4.05	(102.9)
3.00	(76.0)	40	40	3.95	(100.3)
2.90	(73.5)	44	43	3.85	(97.8)
2.80	(71.0)	48	46	3.75	(95.3)
2.70	(68.5)	52	49	3.65	(92.7)
2.60	(66.0)	56	52	3.55	(90.2)
2.50	(63.5)	60	55	3.45	(87.6)
2.40	(61.0)	64	58	3.35	(85.1)
2.30	(58.5)	68	61	3.25	(82.6)
2.20	(56.0)	72	64	3.15	(80.0)
2.10	(53.5)	76	67	3.05	(77.5)
2.00	(51.0)	80	70	2.95	(74.9)
1.90	(48.5)	84	73	2.85	(72.4)
1.80	(45.5)	88	76	2.75	(69.9)
1.70	(43.0)	92	79	2.65	(67.3)
1.60	(40.5)	96	82	2.55	(64.8)
1.50	(38.0)	100	85	2.45	(62.2)
1.40	(35.5)	104	88	2.35	(59.7)
1.30	(33.0)	108	91	2.25	(57.2)
1.20	(30.5)	112	94	2.15	(54.6)
1.10	(28.0)	116	97	2.05	(52.1)
1.00	(25.5)	120	100	1.95	(49.5)
0.90	(23.0)		103	1.85	(47.0)
0.80	(20.5)		106	1.75	(44.5)
0.70	(18.0)		109	1.65	(41.9)
0.60	(15.0)		112	1.55	(39.4)
0.50	(12.5)		115	1.45	(36.8)
0.40	(10.0)		118	1.35	(34.3)
0.30	(7.5)		121	1.25	(31.8)

## D11N, D11R, D11T - 12.50 in. (317.5 mm)

Idlers <sup>(1)</sup> <sup>(2)</sup> <sup>(3)</sup>  
Not for use with Sound Reduction Idler

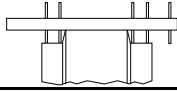

Depth Gauge

Inches	(mm)	% Worn
0.78	(20.0)	0
0.82	(21.0)	8
0.86	(22.0)	16
0.90	(23.0)	24
0.94	(24.0)	32
0.98	(25.0)	40
1.02	(26.0)	48
1.06	(27.0)	56
1.10	(28.0)	64
1.14	(29.0)	72
1.18	(30.0)	76
1.22	(31.0)	80
1.26	(32.0)	84
1.30	(33.0)	88
1.34	(34.0)	92
1.38	(35.0)	96
1.42	(36.0)	100
1.46	(37.0)	104
1.50	(38.0)	108
1.54	(39.0)	112
1.58	(40.0)	116
1.62	(41.0)	120

- 1 Flange width is 5.87 in (149 mm)
- 2 New tread diameter is 35.12 in. (892 mm)
- 3 Wear Chart: 4500

# D11N, D11R, D11T - 12.50 in. (317.5 mm)

Idlers <sup>(1)</sup> <sup>(2)</sup> <sup>(3)</sup>  
 Use with Sound Reduction Idler only



**Depth Gauge**

Inches	(mm)	% Worn
0.78	(20.0)	0
0.80	(20.5)	4
0.82	(21.0)	8
0.84	(21.5)	12
0.86	(22.0)	16
0.88	(22.5)	20
0.90	(23.0)	24
0.92	(23.5)	28
0.94	(24.0)	32
0.96	(24.5)	36
0.98	(25.0)	40
1.00	(25.5)	44
1.02	(26.0)	48
1.04	(26.5)	52
1.06	(27.0)	56
1.08	(27.5)	60
1.10	(28.0)	64
1.12	(28.5)	68
1.14	(29.0)	72
1.16	(29.5)	74
1.18	(30.0)	76
1.20	(30.5)	78
1.22	(31.0)	80
1.24	(31.5)	82
1.26	(32.0)	84
1.28	(32.5)	86
1.30	(33.0)	88
1.32	(33.5)	90
1.34	(34.0)	92
1.36	(34.5)	94
1.38	(35.0)	96
1.40	(35.5)	98
1.42	(36.0)	100
1.44	(36.5)	102
1.46	(37.0)	104
1.48	(37.5)	106
1.50	(38.0)	108
1.52	(38.5)	110
1.54	(39.0)	112
1.56	(39.5)	114
1.58	(40.0)	116
1.60	(40.5)	118
1.62	(41.0)	120



**Ultrasonic**

**Center Flange Wear**

Inches	(mm)	Inches	(mm)
1.64	(41.7)	0.00	(0.0)
1.62	(41.1)	0.02	(0.5)
1.60	(40.6)	0.04	(1.0)
1.58	(40.1)	0.06	(1.5)
1.56	(39.6)	0.08	(2.0)
1.54	(39.1)	0.10	(2.5)
1.52	(38.6)	0.12	(3.0)
1.50	(38.1)	0.14	(3.5)
1.48	(37.6)	0.16	(4.0)
1.46	(37.1)	0.18	(4.5)
1.44	(36.6)	0.20	(5.0)
1.42	(36.1)	0.22	(5.5)
1.40	(35.6)	0.24	(6.0)
1.38	(35.1)	0.26	(6.5)
1.36	(34.5)	0.28	(7.0)
1.34	(34.0)	0.30	(7.5)
1.32	(33.5)	0.32	(8.0)
1.30	(33.0)	0.34	(8.5)
1.28	(32.5)	0.36	(9.0)
1.26	(32.0)	0.38	(9.5)
1.24	(31.5)	0.40	(10.0)
1.22	(31.0)	0.42	(10.5)
1.20	(30.5)	0.44	(11.0)
1.18	(30.0)	0.46	(11.5)

**NOTE**

Ultrasonic measurement is to determine flange wear only.

- 1 Flange width is 5.91 in. (150 mm)
- 2 New tread diameter is 35.20 in. (894.2 mm)
- 3 Wear Chart: 4502

# D11N, D11R, D11T - 12.50 in. (317.5 mm)

## Track Rollers <sup>(1) (2)</sup> Single Flange Optional Large Diameter Roller Use with 200-6325 & 26 Links

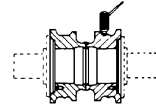
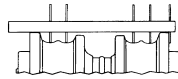
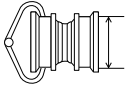

Caliper			Depth Gauge		Ultrasonic	
Inches	(mm)	% Worn	Inches	(mm)	Inches	(mm)
12.16	(309.0)	0	0.67	(17.0)	3.27	(83.1)
11.96	(304.0)	6	0.77	(19.5)	3.17	(80.5)
11.76	(298.5)	12	0.87	(22.0)	3.07	(78.0)
11.56	(293.5)	18	0.97	(24.5)	2.97	(75.4)
11.36	(288.5)	24	1.07	(27.0)	2.87	(72.9)
11.16	(283.5)	30	1.17	(29.5)	2.77	(70.4)
10.96	(278.5)	36	1.27	(32.5)	2.67	(67.8)
10.76	(273.5)	42	1.37	(35.0)	2.57	(65.3)
10.56	(268.0)	48	1.47	(37.5)	2.47	(62.7)
10.36	(263.0)	54	1.57	(40.0)	2.37	(60.2)
10.16	(258.0)	60	1.67	(42.5)	2.27	(57.7)
9.96	(253.0)	66	1.77	(45.0)	2.17	(55.1)
9.76	(248.0)	72	1.87	(47.5)	2.07	(52.6)
9.56	(243.0)	78	1.97	(50.0)	1.97	(50.0)
9.36	(237.5)	84	2.07	(52.5)	1.87	(47.5)
9.16	(232.5)	88	2.17	(55.0)	1.77	(45.0)
8.96	(227.5)	92	2.27	(57.5)	1.67	(42.4)
8.76	(222.5)	96	2.37	(60.0)	1.57	(39.9)
8.56	(217.5)	100	2.47	(62.5)	1.47	(37.3)
8.36	(212.5)	104	2.57	(65.5)	1.37	(34.8)
8.16	(207.5)	108	2.67	(68.0)	1.27	(32.3)
7.96	(202.0)	112	2.77	(70.5)	1.17	(29.7)
7.76	(197.0)	116	2.87	(73.0)	1.07	(27.2)
7.56	(192.0)	120	2.97	(75.5)	0.97	(24.6)
7.36	(187.0)	124	3.07	(78.0)	0.87	(22.1)

1 Flange diameter is 13.50 in. (343 mm)

2 Wear Chart: 5402

# D11N, D11R, D11T - 12.50 in. (317.5 mm)

## Track Rollers <sup>(1) (2)</sup> Single Flange Standard Roller

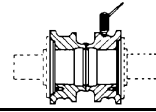
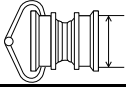

Caliper			Depth Gauge		Ultrasonic	
Inches	(mm)	% Worn	Inches	(mm)	Inches	(mm)
11.30	(287.0)	0	0.67	(17.0)	2.83	(71.9)
11.20	(284.5)	4	0.72	(18.5)	2.78	(70.6)
11.10	(282.0)	8	0.77	(19.5)	2.73	(69.3)
11.00	(279.5)	12	0.82	(21.0)	2.68	(68.1)
10.90	(277.0)	16	0.87	(22.0)	2.63	(66.8)
10.80	(274.5)	20	0.92	(23.5)	2.58	(65.5)
10.70	(272.0)	24	0.97	(24.5)	2.53	(64.3)
10.60	(269.0)	28	1.02	(26.0)	2.48	(63.0)
10.50	(266.5)	32	1.07	(27.0)	2.43	(61.7)
10.40	(264.0)	36	1.12	(28.5)	2.38	(60.5)
10.30	(261.5)	40	1.17	(29.5)	2.33	(59.2)
10.20	(259.0)	44	1.22	(31.0)	2.28	(57.9)
10.10	(256.5)	48	1.27	(32.5)	2.23	(56.6)
10.00	(254.0)	52	1.32	(33.5)	2.18	(55.4)
9.90	(251.5)	56	1.37	(35.0)	2.13	(54.1)
9.80	(249.0)	60	1.42	(36.0)	2.08	(52.8)
9.70	(246.5)	64	1.47	(37.5)	2.03	(51.6)
9.60	(244.0)	68	1.52	(38.5)	1.98	(50.3)
9.50	(241.5)	72	1.57	(40.0)	1.93	(49.0)
9.40	(239.0)	76	1.62	(41.0)	1.88	(47.8)
9.30	(236.0)	80	1.67	(42.5)	1.83	(46.5)
9.20	(233.5)	84	1.72	(43.5)	1.78	(45.2)
9.10	(231.0)	88	1.77	(45.0)	1.73	(43.9)
9.00	(228.5)	92	1.82	(46.0)	1.68	(42.7)
8.90	(226.0)	94	1.87	(47.5)	1.63	(41.4)
8.80	(223.5)	96	1.92	(49.0)	1.58	(40.1)
8.70	(221.0)	98	1.97	(50.0)	1.53	(38.9)
8.60	(218.5)	100	2.02	(51.5)	1.48	(37.6)
8.50	(216.0)	102	2.07	(52.5)	1.43	(36.3)
8.40	(213.5)	104	2.12	(54.0)	1.38	(35.1)
8.30	(211.0)	106	2.17	(55.0)	1.33	(33.8)
8.20	(208.5)	108	2.22	(56.5)	1.28	(32.5)
8.10	(205.5)	110	2.27	(57.5)	1.23	(31.2)
8.00	(203.0)	112	2.32	(59.0)	1.18	(30.0)
7.90	(200.5)	114	2.37	(60.0)	1.13	(28.7)
7.80	(198.0)	116	2.42	(61.5)	1.08	(27.4)
7.70	(195.5)	118	2.47	(62.5)	1.03	(26.2)
7.60	(193.0)	120	2.52	(64.0)	0.98	(24.9)

1 Flange diameter is 12.64 in. (321 mm)

2 Wear Chart: 5400



# D11N, D11R, D11T - 12.50 in. (317.5 mm)

## Track Rollers <sup>(1) (2)</sup> Double Flange

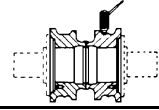
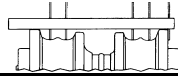
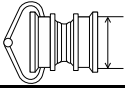

Caliper		% Worn	Depth Gauge		Ultrasonic	
Inches	(mm)		Inches	(mm)	Inches	(mm)
10.90	(277.0)	0	0.86	(22.0)	2.64	(67.1)
10.80	(274.5)	6	0.91	(23.0)	2.59	(65.8)
10.70	(272.0)	12	0.96	(24.5)	2.54	(64.5)
10.60	(269.0)	18	1.01	(25.5)	2.49	(63.2)
10.50	(266.5)	24	1.06	(27.0)	2.44	(62.0)
10.40	(264.0)	30	1.11	(28.0)	2.39	(60.7)
10.30	(261.5)	36	1.16	(29.5)	2.34	(59.4)
10.20	(259.0)	42	1.21	(30.5)	2.29	(58.2)
10.10	(256.5)	48	1.26	(32.0)	2.24	(56.9)
10.00	(254.0)	54	1.31	(33.5)	2.19	(55.6)
9.90	(251.5)	60	1.36	(34.5)	2.14	(54.4)
9.80	(249.0)	64	1.41	(36.0)	2.09	(53.1)
9.70	(246.5)	67	1.46	(37.0)	2.04	(51.8)
9.60	(244.0)	70	1.51	(38.5)	1.99	(50.5)
9.50	(241.5)	73	1.56	(39.5)	1.94	(49.3)
9.40	(239.0)	76	1.61	(41.0)	1.89	(48.0)
9.30	(236.0)	79	1.66	(42.0)	1.84	(46.7)
9.20	(233.5)	82	1.71	(43.5)	1.79	(45.5)
9.10	(231.0)	85	1.76	(44.5)	1.74	(44.2)
9.00	(228.5)	88	1.81	(46.0)	1.69	(42.9)
8.90	(226.0)	91	1.86	(47.0)	1.64	(41.7)
8.80	(223.5)	94	1.91	(48.5)	1.59	(40.4)
8.70	(221.0)	97	1.96	(50.0)	1.54	(39.1)
8.60	(218.5)	100	2.01	(51.0)	1.49	(37.8)
8.50	(216.0)	103	2.06	(52.5)	1.44	(36.6)
8.40	(213.5)	106	2.11	(53.5)	1.39	(35.3)
8.30	(211.0)	109	2.16	(55.0)	1.34	(34.0)
8.20	(208.5)	112	2.21	(56.0)	1.29	(32.8)
8.10	(205.5)	115	2.26	(57.5)	1.24	(31.5)
8.00	(203.0)	118	2.31	(58.5)	1.19	(30.2)
7.90	(200.5)	121	2.36	(60.0)	1.14	(29.0)
7.80	(198.0)	124	2.41	(61.0)	1.09	(27.7)
7.70	(195.5)	127	2.46	(62.5)	1.04	(26.4)

1 Flange diameter is 12.64 in. (321 mm)

2 Wear Chart: 6300

# D11N, D11R, D11T - 12.50 in. (317.5 mm)

**Sprockets <sup>(1)</sup>**  
**Not for use with Sound Reduction Sprocket**



Tape Measure		
Inches	(mm)	% Worn
14.05	(357.0)	0
14.00	(355.5)	5
13.95	(354.5)	10
13.90	(353.0)	15
13.85	(352.0)	19
13.80	(350.5)	22
13.75	(349.5)	25
13.70	(348.0)	28
13.65	(346.5)	31
13.60	(345.5)	34
13.55	(344.0)	37
13.50	(343.0)	40
13.45	(341.5)	43
13.40	(340.5)	46
13.35	(339.0)	49
13.30	(338.0)	52
13.25	(336.5)	55
13.20	(335.5)	58
13.15	(334.0)	61
13.10	(332.5)	64
13.05	(331.5)	67
13.00	(330.0)	70
12.95	(329.0)	73
12.90	(327.5)	76
12.85	(326.5)	79
12.80	(325.0)	82
12.75	(324.0)	85
12.70	(322.5)	88
12.65	(321.5)	91
12.60	(320.0)	94
12.55	(319.0)	97
12.50	(317.5)	100
12.45	(316.0)	103
12.40	(315.0)	106
12.35	(313.5)	109
12.30	(312.5)	112
12.25	(311.0)	115
12.20	(310.0)	118
12.15	(308.5)	121

**NOTE:** Measure across 3 teeth

# D11N, D11R, D11T - 12.50 in. (317.5 mm)

## Sprockets <sup>(1)</sup> Sound Reduction Sprocket only



Tape Measure		
Inches	(mm)	% Worn
13.80	(350.5)	0
13.75	(349.5)	5
13.70	(348.0)	10
13.65	(346.5)	15
13.60	(345.5)	20
13.55	(344.0)	25
13.50	(343.0)	30
13.45	(341.5)	35
13.40	(340.5)	40
13.35	(339.0)	45
13.30	(338.0)	50
13.25	(336.5)	55
13.20	(335.5)	58
13.15	(334.0)	61
13.10	(332.5)	64
13.05	(331.5)	67
13.00	(330.0)	70
12.95	(329.0)	73
12.90	(327.5)	76
12.85	(326.5)	79
12.80	(325.0)	82
12.75	(324.0)	85
12.70	(322.5)	88
12.65	(321.5)	91
12.60	(320.0)	94
12.55	(319.0)	97
12.50	(317.5)	100
12.45	(316.0)	103
12.40	(315.0)	106
12.35	(313.5)	109
12.30	(312.5)	112
12.25	(311.0)	115
12.20	(310.0)	118
12.15	(308.5)	121

# D8N, D8R, D8T - 8.58 in. (218 mm)

## Track Links <sup>(1)</sup> SystemOne™Track 304-5680

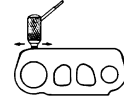
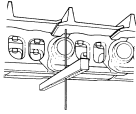

Depth Gauge		Allowable Wear Lesser % <sup>(2)</sup> Worn	Ultrasonic	
Inches	(mm)		Inches	(mm)
5.98	(152.0)	0	1.67	(42.4)
5.96	(151.5)	5	1.65	(41.9)
5.94	(151.0)	10	1.63	(41.4)
5.92	(150.5)	15	1.61	(40.9)
5.90	(150.0)	20	1.59	(40.4)
5.88	(149.5)	25	1.57	(39.9)
5.86	(149.0)	30	1.55	(39.4)
5.84	(148.5)	35	1.53	(38.9)
5.82	(148.0)	40	1.51	(38.4)
5.80	(147.5)	45	1.49	(37.8)
5.78	(147.0)	50	1.47	(37.3)
5.76	(146.5)	55	1.45	(36.8)
5.74	(146.0)	60	1.43	(36.3)
5.72	(145.5)	64	1.41	(35.8)
5.70	(145.0)	68	1.39	(35.3)
5.68	(144.5)	71	1.37	(34.8)
5.66	(144.0)	74	1.35	(34.3)
5.64	(143.5)	77	1.33	(33.8)
5.62	(142.5)	81	1.31	(33.3)
5.60	(142.0)	84	1.29	(32.8)
5.58	(141.5)	87	1.27	(32.3)
5.56	(141.0)	90	1.25	(31.8)
5.54	(140.5)	94	1.23	(31.2)
5.52	(140.0)	97	1.21	(30.7)
5.50	(139.5)	100	1.19	(30.2)
5.48	(139.0)	103	1.17	(29.7)
5.46	(138.5)	107	1.15	(29.2)
5.44	(138.0)	110	1.13	(28.7)
5.42	(137.5)	113	1.11	(28.2)
5.40	(137.0)	116	1.09	(27.7)
5.38	(136.5)	120	1.07	(27.2)

1 Wear Chart: 131 Lesser

2 If 304-5680 link cracking has NOT been experienced, please use the Greater Allowable Wear chart located on, page 209. Also see, page 88 for further definition of Link Allowable Wear.

**D8L, D8N, D8R, D8T, 578, 583R, 583T, 587T, PL83, PL87 - 8.50 in. (215.9 mm)**

**Track Links <sup>(1)</sup>  
8E-4505 & 06  
8E-4513 & 14**

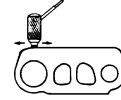
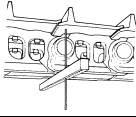

Depth Gauge		Allowable Wear Lesser % <sup>(2)</sup> Worn	Ultrasonic	
Inches	(mm)		Inches	(mm)
5.90	(150.0)	0	1.88	(47.8)
5.88	(149.5)	5	1.86	(47.2)
5.86	(149.0)	10	1.84	(46.7)
5.84	(148.5)	15	1.82	(46.2)
5.82	(148.0)	20	1.80	(45.7)
5.80	(147.5)	25	1.78	(45.2)
5.78	(147.0)	30	1.76	(44.7)
5.76	(146.5)	35	1.74	(44.2)
5.74	(146.0)	40	1.72	(43.7)
5.72	(145.5)	45	1.70	(43.2)
5.70	(145.0)	50	1.68	(42.7)
5.68	(144.5)	55	1.66	(42.2)
5.66	(144.0)	60	1.64	(41.7)
5.64	(143.5)	64	1.62	(41.1)
5.62	(142.5)	68	1.60	(40.6)
5.60	(142.0)	71	1.58	(40.1)
5.58	(141.5)	74	1.56	(39.6)
5.56	(141.0)	77	1.54	(39.1)
5.54	(140.5)	81	1.52	(38.6)
5.52	(140.0)	84	1.50	(38.1)
5.50	(139.5)	87	1.48	(37.6)
5.48	(139.0)	90	1.46	(37.1)
5.46	(138.5)	94	1.44	(36.6)
5.44	(138.0)	97	1.42	(36.1)
5.42	(137.5)	100	1.40	(35.6)
5.40	(137.0)	103	1.38	(35.1)
5.38	(136.5)	107	1.36	(34.5)
5.36	(136.0)	110	1.34	(34.0)
5.34	(135.5)	113	1.32	(33.5)
5.32	(135.0)	116	1.30	(33.0)
5.30	(134.5)	120	1.28	(32.5)

1 Wear Chart: 125 Lesser

2 If 8E-4505 & 06 or 8E-4513 & 14 link cracking has NOT been experienced, please use the Greater Allowable Wear chart located on, page 210. Also see, page 88 for further definition of Link Allowable Wear.

# D9N, D9R, D9T - 9.45 in. (240 mm)

## Track Links <sup>(1)</sup> 9W-2743 & 44 7T-2275 & 76

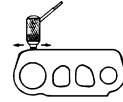
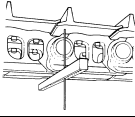

Depth Gauge		Allowable Wear Lesser % <sup>(2)</sup> Worn	Ultrasonic	
Inches	(mm)		Inches	(mm)
6.53	(166.0)	0	2.28	(57.9)
6.51	(165.5)	5	2.26	(57.4)
6.49	(165.0)	10	2.24	(56.9)
6.47	(164.5)	15	2.22	(56.4)
6.45	(164.0)	20	2.20	(55.9)
6.43	(163.5)	25	2.18	(55.4)
6.41	(163.0)	30	2.16	(54.9)
6.39	(162.5)	35	2.14	(54.4)
6.37	(162.0)	40	2.12	(53.8)
6.35	(161.5)	45	2.10	(53.3)
6.33	(161.0)	50	2.08	(52.8)
6.31	(160.5)	55	2.06	(52.3)
6.29	(160.0)	60	2.04	(51.8)
6.27	(159.5)	64	2.02	(51.3)
6.25	(159.0)	68	2.00	(50.8)
6.23	(158.0)	71	1.98	(50.3)
6.21	(157.5)	74	1.96	(49.8)
6.19	(157.0)	77	1.94	(49.3)
6.17	(156.5)	81	1.92	(48.8)
6.15	(156.0)	84	1.90	(48.3)
6.13	(155.5)	87	1.88	(47.8)
6.11	(155.0)	90	1.86	(47.2)
6.09	(154.5)	94	1.84	(46.7)
6.07	(154.0)	97	1.82	(46.2)
6.05	(153.5)	100	1.80	(45.7)
6.03	(153.0)	103	1.78	(45.2)
6.01	(152.5)	107	1.76	(44.7)
5.99	(152.0)	110	1.74	(44.2)
5.97	(151.5)	113	1.72	(43.7)
5.95	(151.0)	116	1.70	(43.2)
5.93	(150.5)	120	1.68	(42.7)

1 Wear Chart: 160 Lesser

2 If 9W-2743 & 44, 7T-2275 & 76 link cracking has NOT been experienced, please use the Greater Allowable Wear chart located [on, page 227](#). Also [see, page 88](#) for further definition of Link Allowable Wear.

Track Links <sup>(1)</sup>  
 7T-7629 & 30  
 7T-4137 & 38

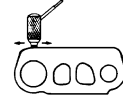
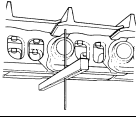

Depth Gauge		Allowable Wear Lesser % <sup>(2)</sup> Worn	Ultrasonic	
Inches	(mm)		Inches	(mm)
6.34	(161.0)	0	1.85	(47.0)
6.32	(160.5)	5	1.83	(46.5)
6.30	(160.0)	10	1.81	(46.0)
6.28	(159.5)	15	1.79	(45.5)
6.26	(159.0)	20	1.77	(45.0)
6.24	(158.5)	25	1.75	(44.5)
6.22	(158.0)	30	1.73	(43.9)
6.20	(157.5)	35	1.71	(43.4)
6.18	(157.0)	40	1.69	(42.9)
6.16	(156.5)	45	1.67	(42.4)
6.14	(156.0)	50	1.65	(41.9)
6.12	(155.5)	55	1.63	(41.4)
6.10	(155.0)	60	1.61	(40.9)
6.08	(154.5)	64	1.59	(40.4)
6.06	(154.0)	68	1.57	(39.9)
6.04	(153.5)	71	1.55	(39.4)
6.02	(153.0)	74	1.53	(38.9)
6.00	(152.5)	77	1.51	(38.4)
5.98	(152.0)	81	1.49	(37.8)
5.96	(151.5)	84	1.47	(37.3)
5.94	(151.0)	87	1.45	(36.8)
5.92	(150.5)	90	1.43	(36.3)
5.90	(150.0)	94	1.41	(35.8)
5.88	(149.5)	97	1.39	(35.3)
5.86	(149.0)	100	1.37	(34.8)
5.84	(148.5)	103	1.35	(34.3)
5.82	(148.0)	107	1.33	(33.8)
5.80	(147.5)	110	1.31	(33.3)
5.78	(147.0)	113	1.29	(32.8)
5.76	(146.5)	116	1.27	(32.3)
5.74	(146.0)	120	1.25	(31.8)

1 Wear Chart: 141 Lesser

2 If 7T-7629 & 30, 7T-4137 & 38 link cracking has NOT been experienced, please use the Greater Allowable Wear chart located [on, page 237](#). Also [see, page 88](#) for further definition of Link Allowable Wear.

# D10N, D10R, D10T - 10.25 in. (260.4 mm)

Track Links <sup>(1)</sup>  
 9W-5265 & 66  
 7T-0715 & 16  
 320-3053 & 54

Standard Link or Scallop Resistant Link

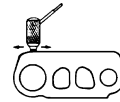
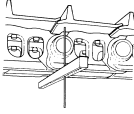

Depth Gauge		Allowable Wear Lesser % <sup>(2)</sup> Worn	Ultrasonic	
Inches	(mm)		Inches	(mm)
7.12	(181.0)	0	2.36	(59.9)
7.10	(180.5)	5	2.34	(59.4)
7.08	(180.0)	10	2.32	(58.9)
7.06	(179.5)	15	2.30	(58.4)
7.04	(179.0)	20	2.28	(57.9)
7.02	(178.5)	25	2.26	(57.4)
7.00	(178.0)	30	2.24	(56.9)
6.98	(177.5)	35	2.22	(56.4)
6.96	(177.0)	40	2.20	(55.9)
6.94	(176.5)	45	2.18	(55.4)
6.92	(176.0)	50	2.16	(54.9)
6.90	(175.5)	55	2.14	(54.4)
6.88	(175.0)	60	2.12	(53.8)
6.86	(174.0)	64	2.10	(53.3)
6.84	(173.5)	68	2.08	(52.8)
6.82	(173.0)	71	2.06	(52.3)
6.80	(172.5)	74	2.04	(51.8)
6.78	(172.0)	77	2.02	(51.3)
6.76	(171.5)	81	2.00	(50.8)
6.74	(171.0)	84	1.98	(50.3)
6.72	(170.5)	87	1.96	(49.8)
6.70	(170.0)	90	1.94	(49.3)
6.68	(169.5)	94	1.92	(48.8)
6.66	(169.0)	97	1.90	(48.3)
6.64	(168.5)	100	1.88	(47.8)
6.62	(168.0)	103	1.86	(47.2)
6.60	(167.5)	107	1.84	(46.7)
6.58	(167.0)	110	1.82	(46.2)
6.56	(166.5)	113	1.80	(45.7)
6.54	(166.0)	116	1.78	(45.2)
6.52	(165.5)	120	1.76	(44.7)

1 Wear Chart: 183 Lesser

2 If 9W-5265 & 66, 7T-0715 & 16, or 320-3053 & 54 link cracking has NOT been experienced, please use the Greater Allowable Wear chart located [on, page 245](#). Also [see, page 88](#) for further definition of Link Allowable Wear.



Track Links <sup>(1)</sup>  
 9W-5723 & 24  
 9W-5933 & 34

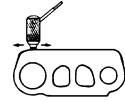
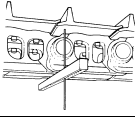

Depth Gauge		Allowable Wear Lesser % <sup>(2)</sup> Worn	Ultrasonic	
Inches	(mm)		Inches	(mm)
7.12	(181.0)	0	1.92	(48.8)
7.10	(180.5)	5	1.90	(48.3)
7.08	(180.0)	10	1.88	(47.8)
7.06	(179.5)	15	1.86	(47.2)
7.04	(179.0)	20	1.84	(46.7)
7.02	(178.5)	25	1.82	(46.2)
7.00	(178.0)	30	1.80	(45.7)
6.98	(177.5)	35	1.78	(45.2)
6.96	(177.0)	40	1.76	(44.7)
6.94	(176.5)	45	1.74	(44.2)
6.92	(176.0)	50	1.72	(43.7)
6.90	(175.5)	55	1.70	(43.2)
6.88	(175.0)	60	1.68	(42.7)
6.86	(174.0)	64	1.66	(42.2)
6.84	(173.5)	68	1.64	(41.7)
6.82	(173.0)	71	1.62	(41.1)
6.80	(172.5)	74	1.60	(40.6)
6.78	(172.0)	77	1.58	(40.1)
6.76	(171.5)	81	1.56	(39.6)
6.74	(171.0)	84	1.54	(39.1)
6.72	(170.5)	87	1.52	(38.6)
6.70	(170.0)	90	1.50	(38.1)
6.68	(169.5)	94	1.48	(37.6)
6.66	(169.0)	97	1.46	(37.1)
6.64	(168.5)	100	1.44	(36.6)
6.62	(168.0)	103	1.42	(36.1)
6.60	(167.5)	107	1.40	(35.6)
6.58	(167.0)	110	1.38	(35.1)
6.56	(166.5)	113	1.36	(34.5)
6.54	(166.0)	116	1.34	(34.0)
6.52	(165.5)	120	1.32	(33.5)

1 Wear Chart: 182 Lesser

2 If 9W-5723 & 24, 9W-5933 & 34 link cracking has NOT been experienced, please use the Greater Allowable Wear chart located on, page 255. Also see, page 88 for further definition of Link Allowable Wear.

# D11N, D11R, D11T - 12.50 in. (317.5 mm)

**Track Links <sup>(1)</sup>**  
**6T-8049 & 50**  
**320-3541 & 42**  
**Standard Link or Scallop Resistant Link**

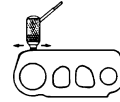
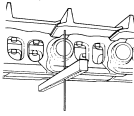

Depth Gauge		Allowable Wear Lesser % <sup>(2)</sup> Worn	Ultrasonic	
Inches	(mm)		Inches	(mm)
7.79	(198.0)	0	2.24	(56.9)
7.77	(197.5)	5	2.22	(56.4)
7.75	(197.0)	10	2.20	(55.9)
7.73	(196.5)	15	2.18	(55.4)
7.71	(196.0)	20	2.16	(54.9)
7.69	(195.5)	25	2.14	(54.4)
7.67	(195.0)	30	2.12	(53.8)
7.65	(194.5)	35	2.10	(53.3)
7.63	(194.0)	40	2.08	(52.8)
7.61	(193.5)	45	2.06	(52.3)
7.59	(193.0)	50	2.04	(51.8)
7.57	(192.5)	55	2.02	(51.3)
7.55	(192.0)	60	2.00	(50.8)
7.53	(191.5)	64	1.98	(50.3)
7.51	(191.0)	68	1.96	(49.8)
7.49	(190.0)	71	1.94	(49.3)
7.47	(189.5)	74	1.92	(48.8)
7.45	(189.0)	77	1.90	(48.3)
7.43	(188.5)	81	1.88	(47.8)
7.41	(188.0)	84	1.86	(47.2)
7.39	(187.5)	87	1.84	(46.7)
7.37	(187.0)	90	1.82	(46.2)
7.35	(186.5)	94	1.80	(45.7)
7.33	(186.0)	97	1.78	(45.2)
7.31	(185.5)	100	1.76	(44.7)
7.29	(185.0)	103	1.74	(44.2)
7.27	(184.5)	107	1.72	(43.7)
7.25	(184.0)	110	1.70	(43.2)
7.23	(183.5)	113	1.68	(42.7)
7.21	(183.0)	116	1.66	(42.2)
7.19	(182.5)	120	1.64	(41.7)

1 Wear Chart: 200 Lesser

2 If 6T-8049 & 50, 320-3541 & 42 link cracking has NOT been experienced, please use the Greater Allowable Wear chart located [on, page 264](#). Also [see, page 88](#) for further definition of Link Allowable Wear.





## Undercarriage Identification

The easiest way to identify track is to read the part number forged into the link. This list cross-references link part numbers to the correct percent worn chart pages.

## Genuine Cat® Undercarriage

Model	Pitch	Link Part Number	Wear Chart Pages
D3C, D3G, D3K D4C, D4G, D4K	6.91 in. (175.5 mm)	260-6740 233-5188	From, page 299 – To, page 309
D3 (All) D4B, D4C, D4G, D4K 931, 933, 935	6.125 in. (155.6 mm)	6Y-0935 & 36 6S-8343 & 44 257-7765 & 66	From, page 310 – To, page 326
D4, D4D, D4E 941	6.75 in. (171.5 mm)	9K-6628 & 29 7K-1825 & 26 5K-9423 & 24 5K-9457 & 58	From, page 327 – To, page 340
D5K	7.50 in. (190 mm)	235-2529	See, page 342
D5K	6.75 in. (171.5 mm)	6Y-9261 & 62	From, page 343 – To, page 355
D5C, D5G, 939	6.75 in. (171.5 mm)	108-0947 & 48 6Y-9261 & 62 235-2514	From, page 357 – To, page 377
D5, D5B 951, 955, 561	6.91 in. (175.5 mm)	7T-4539 & 40 257-8012 & 13 3P-7153 & 54 175-8248 & 49	From, page 378 – To, page 399
D6K, PL61	7.50 in (190 mm)	235-2529	From, page 400 – To, page 411
D6, D6B D6C, D6D 955	8.00 in. (203.2 mm)	8E-7405 & 06 378-8241 & 42 228-2735 & 36 7T-4645 & 46 3P-1112 & 13 175-8256 & 57	From, page 412 – To, page 444
D7E Electric Drive	8.50 in (215.9 mm)	6I-9239 & 40	From, page 445 – To, page 453
D7, D7D, D7E D7F, D7G 977 571 572	8.50 in. (215.9 mm)	233-0385 & 86 289-3083 & 84 7T-4657 & 58 8S-2589 & 90 188-5251 & 52	From, page 454 – To, page 478
D8 583 983	9.00 in. (228.7 mm)	7S-9181 & 82 188-5531 & 32	From, page 480 – To, page 491
D9 594	10.25 in. (260.4 mm)	8E-4055 & 56 9S-1927 & 28	From, page 492 – To, page 501

To determine percent worn for links not listed here, see [Former Link Service Limits](#) , page 30.

# Components

---

## Variables That Affect Wear Life

See the following pages for details on the effects of:

### Page

Controllable Variables	See, page 10
Track Adjustment`	See, page 10
Shoe Width	See, page 11
Alignment	See, page 13
Non-Controllable Variables	See, page 17
Soil & Underfoot Conditions	See, page 17
Environmental Variables	See, page 19
Partially Controllable Variables	See, page 22

---

## Components

### Links

See, page 24 through, page 28 for detailed link information.

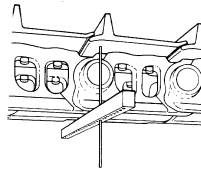

**Measurement** — Measure the track link over the centerline of the pin and bushing bores. See, page 24 for details.

**Wear Patterns** — See, page 25 through, page 26 for a detailed discussion of link wear patterns.

**Split Master Links** — Use the assembly procedures on, page 28 for split master links. Refer to “Shoes” on, page 287 for bolt torque specifications.

### Bushing — Sealed & Lubricated Track

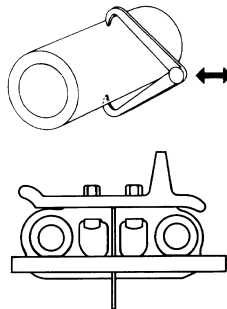

**Measurement** — Use the caliper, depth gauge or Ultrasonic Wear Indicator to measure the vertical position to the closest 0.01 in. (0.25 mm). The vertical position is expected to be the most worn position for Sealed and Lubricated Track bushings on low sprocket machines. Measurement of other wear positions can be made, but are not expected to be critical.

**Bushing Allowable Wear** — Bushing allowable wear is based on the remaining strength to resist cracks. For high impact underfoot conditions use lesser allowable wear. For low impact use greater allowable wear.

## Dry Joints

See, [page 37](#) for dry joint inspection procedures and recommended service. If a dry joint is found, measure pitch extension over that one joint. Schedule service if the pitch exceeds these limits:

Model	New Track Pitch	Single Joint Wear Limit
D3 D4 931 933 935	6.125 in. (155.6 mm)	6.50 in. (165 mm)
D4 941	6.75 in. (171.5 mm)	7.25 in. (185 mm)
D3 D4 D5 951 955 561	6.91 in. (171.5 mm)	7.50 in. (190 mm)
D5 D6	7.50 in. (190 mm)	8.00 in. (203.2 mm)
D6 955	8.00 in. (203.2 mm)	8.67 in. (220 mm)
D7 977 571 572	8.50 in. (215.9 mm)	9.12 in. (321 mm)
D8 983	9.00 in. (228.7 mm)	9.75 in. (250 mm)
D9 594	10.25 in. (260.4 mm)	11.00 in. (280 mm)

# Components

---

## Bushing — Sealed Track — External

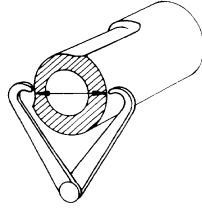

**Measurement** — To measure external wear use the caliper or the Ultrasonic Wear Indicator. Measure the minimum diameter regardless of the position (vertical, forward, reverse). See details on measurement procedures [on, page 39](#).

**Bushing Allowable Wear** — Bushing allowable wear is based on the remaining strength to resist cracks. For low sprocket machines, the choice between two allowable wears is based on high or low impact conditions because the sprocket is close to the ground and subject to impact.

## Pin and Bushing — Sealed Track — Internal

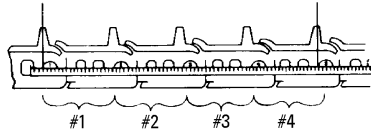

**Measurement** — Sealed track internal wear is measured by determining the pitch extended length over four adjacent sections with a tape measure calibrated in 0.02 in.(0.5 mm) increments. The track must be tight before measuring. Measure from the side of one pin to the same side of the fifth pin away (which includes 4 sections). See details on measurement procedure [on, page 42](#).

## Shoes

[See, page 44](#) for detailed shoe information.

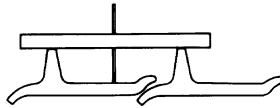

**Measurement** — Use the depth gauge or the Ultrasonic Wear Indicator to measure shoes.



**Shoe & Master Link Bolt Torque/Turn Specifications**

Model	Bolt Size	Torque <sup>(1)</sup>	Additional Turn	
			Regular Shoe	Master Link Master Shoe
D3 D4 931 933 935	1/2 in.	130 ± 25 ft. lb. 175 ± 40 Nm	—	—
D3 D4 931 933 935	9/16 in.	65 ± 15 ft. lb. 90 ± 20 Nm	+ 1/3 turn	+ 1/2 turn
D4 D5 D6 941 943 951 561	5/8 in.	126 ± 30 ft. lb. 170 ± 40 Nm	+ 1/3 turn	+ 1/2 turn
D6 D7 955 977 571 572	3/4 in.	220 ± 40 ft. lb. 300 ± 50 Nm	+ 1/3 turn	+ 1/2 turn
D7E	7/8 in.	250 ± 50 ft. lb. 340 ± 70 Nm	+ 1/3 turn	+ 1/2 turn
D8 983	7/8 in.	250 ± 50 ft. lb. 340 ± 70 Nm	+ 1/3 turn	+ 1/2 turn
D9 594	1 in.	400 ± 50 ft. lb. 540 ± 70 Nm	+ 1/3 turn	+ 1/2 turn

1 See, page 29 for assembling and torque tightening procedures.

# Components

## SystemOne Shoe and Master Link Track Torque/Turn Specifications\*

Model	Bolt Size	Standard Links Track Shoes		Clamp Master (Open Window)		Clamp Master (Center Strut)	
		Pre Torque	Additional Turn	Pre Torque	Additional Turn	Pre Torque	Additional Turn
D3G, D3K D4G, D4K	16 mm	107 ± 18 ft-lb 145 ± 25 N·m	1/3 turn			166 ± ft-lb 225 ± N·m	1/3 turn
D5G	16 mm	107 ± 18 ft-lb 145 ± 25 N·m	1/3 turn	184 ± 18 ft-lb 250 ± 25 N·m	4 x 1/4 turn (2)		
D5K	18 mm	148 ± 18 ft-lb 200 ± 25 N·m	1/3 turn	184 ± 18 ft-lb 250 ± 25 N·m	4 x 1/4 turn (2)	258 ± 18 ft-lb 350 ± 25 N·m	1/3 turn
D6K	18 mm	148 ± 18 ft-lb 200 ± 25 N·m	1/3 turn	184 ± 18 ft-lb 250 ± 25 N·m	4 x 1/4 turn (2)	258 ± 18 ft-lb 350 ± 25 N·m	1/3 turn

\* For detailed Installation and Removal of SystemOne Clamp Masters, see Undercarriage Reconditioning Bulletin, REHS2220.

\*\* Use the [Assembling and Tightening Procedure](#), page 29.

### Idlers



See, [page 49 through, page 51](#) for detailed idler information, including Conventional, Center Tread, and Relieved Center Tread Idlers.

**Measurement** — Use the Depth Gauge, Ultrasonic Wear Indicator, or Caliper to measure idlers.

### Sprocketed Center Tread Idlers and Relieved Sprocketed Center Tread Idlers (for D6K models)

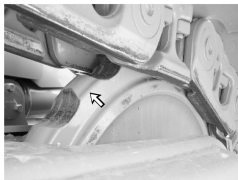

#### Measurement Technique

Sprocketed Center Tread Idler or Relieved Sprocketed Idler tread wear is measured with the depth gauge, tape or small caliper. However, measurement with the caliper may not be accurate if there is no room to use it. Angled caliper measurement would give a greater wear measurement than actual. The sprocketed idlers cannot be measured with the Ultrasonic Wear Indicator.

The measurement location is at the idler root as illustrated on the next page.

- 2 Turn each bolt 90 degrees (1/4) at a time for four (4) turns so deflection is uniform. These turns are to be completed in a clockwise pattern.

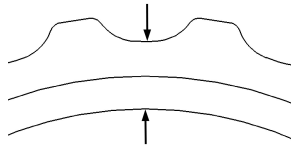

## Rebuildability

Sprocketed Center Tread Idlers are not rebuildable.

## Installation

Note that the part number side of the idler also has an oil fill plug. This side of the idler should be installed to face the outside of the machine.

For complete details on the improved D6K Sprocketed Idlers, reference Special Instruction REHS7603.

## Carrier Rollers

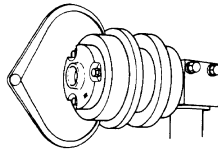

See, [page 53 through, page 55](#) for detailed carrier roller information.

**Measurement** — Use the caliper or the Ultrasonic Wear Indicator to measure carrier rollers.

## Track Rollers

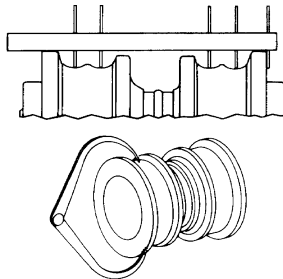

See, [page 56 through, page 59](#) for detailed track roller information.

**Measurement** — Track rollers can be measured with a depth gauge, a caliper or an Ultrasonic Wear Indicator. The wear charts include both measurements. For instructions on how to make either measurement, see, [page 56](#).

# Components

## Roller Flange Sequence

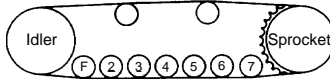

From the chart which follows, you will note that the rear roller (the roller nearest the sprocket) is usually a single flange roller. If a double flange roller were used as the rear roller, interference could occur between the inner flange and the sprocket teeth. Therefore, a double flange roller should not usually be placed in the rear position.

Model	Rollers Per Side	Roller Position							
		F	2	3	4	5	6	7	8
D2	4	S	D	D	S				
D3	7	D	D	S	S	D	S	S	
D3	5	S	D	S	D	S			
D3 LGP	6	S	D	S	S	D	S		
D3G XL, D3K XL	6	S	S	S	S	S	S		
D3 LGP, D3K LGP	6	S	S	S	S	S	S		
D4NC	4	S	D	D	S				
D4, D4D, D4E	5	S	D	S	D	S			
D4C, D4G	5	S	D	S	D	S			
D4C LGP	6	S	D	S	S	D	S		
D4C XL	6	S	D	S	S	D	S		
D4G LGP	6	S	D	S	S	D	S		
D4G LGP, D4K LGP	6	S	S	S	S	S	S		
D4G XL	6	S	D	S	S	D	S		
D4G XL, D4K XL	6	S	S	S	S	S	S		
D5, D5B	6	S	D	D	S	D	S		
D5 LGP	7	S	D	D	S	D	D	S	
D5C, D5G	6	S	D	S	S	D	S		
D5C, D5G	5	D	D	S	D	S			
D5K	7	S	D	S	S	D	S	D	
D5K	7	S	S	S	S	S	S	S	
D6	6	S	D	D	D	D	S		
D6 LGP	7	D	D	S	D	S	D	S	
D6B, D6NC	6	S	D	D	D	D	S		
D6C, D6C	6	D	S	D	S	D	S		
D6K	7	S	S	S	S	S	S	S	
D7NC (8.00 in.)	5	S	D	S	D	S			
D7	6	D	S	D	S	D	S		
D7 LGP	7	D	D	S	D	S	D	S	
D7D, D7F, D7G	6	D	S	D	S	D	S		
D7E (Electric Drive)	7	S	D	S	D	S	D	S	
D7E LGP (Electric Drive)	8	S	D	S	D	D	S	D	S

Model	Rollers Per Side	Roller Position							
		F	2	3	4	5	6	7	8
D8	7	D	D	S	S	D	D	S	
D8	6	D	S	D	S	D	S		
D8NC (8.00 in.)	7	D	D	S	D	S	D	S	
D8H, D8K	7	D	D	S	D	S	D	S	
D8H, D8K	6	D	S	D	S	D	S		
D9, D9D, D9E, D9G, D9H	7	D	D	S	D	S	D	S	
931	5	S	D	S	D	S			
933C, 933E, 933F	5	D	D	S	D	S			
935	5	D	S	S	D	S			
941	5	D	D	S	D	S			
951B, 951 LGP	5	S	D	S	D	S			
951A	5	D	S	D	S	D			
955F, 955E, 955C	5	D	D	S	D	S			
955H	6	S	D	D	S	D	S		
955K, 955L	6	S	D	D	S	D	S		
977D	7	S	D	D	D	D	D	S	
977E, 977H, 977K	7	D	D	S	D	S	D	S	
983	7	D	D	S	D	S	D	S	

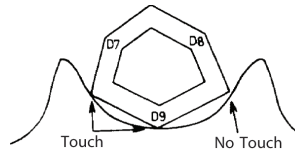

Do Not Reuse Sprocket with turned (or replaced) Bushings

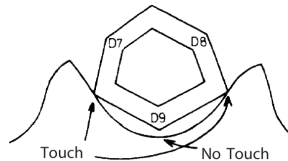

OK to Reuse Sprocket with turned (or replaced) Bushings

## Sprockets

See, page 60 through, page 63 for detailed sprocket information.

**Measurement** — Use the appropriate sprocket reuse indicator gauge (D9, D8, D7 — 5P-8617; D6, D5, D4 — 5P-8616) at bushing turn time to determine reusability.

For D7E Electric Drive models, refer to Service Mag SEPD1459 for details on wear measurement and replacement recommendations.

**Sprocket Bolt Torques** — Use the torque-turn tightening method on, page 63.

## Components

### Sprocket Bolt Torque Specifications

Model	Bolt Size	Torque	Additional Turn
D3	1/2 in.	50 ± 8 ft. lb.	+ 1/3 turn
D4		70 ± 10 Nm	
D5	5/8 in.	130 ± 30 ft. lb.	+ 1/3 turn
D5C		175 ± 40 Nm	
D6			
561			
955			
935C	M16	75 ± 15 ft. lb. 100 ± 20 Nm	+ 1/3 turn
D7	3/4 in.	220 ± 40 ft. lb.	+ 1/3 turn
571		300 ± 50 Nm	
572			
977			
D8	7/8 in.	250 ± 50 ft. lb.	+ 1/3 turn
D9		340 ± 70 Nm	
583			
983			
D9	1 in.	250 ± 50 ft. lb.	+ 1/3 turn
594		340 ± 70 Nm	

**Guards** — See, [page 64](#) for detailed information on track guiding guards and track roller guards.

### Track Adjustment For Low Sprocket Track-Type Tractors and Loaders (except 943, 953, 963 and 973 Loaders)

For track sag and track adjustment of D7E Electric Drive machines, [see, page 296 through, page 297](#). For complete details, reference D7E Operation and Maintenance Manual SEBU8200.

This track adjustment procedure enables users to achieve longer undercarriage component life.

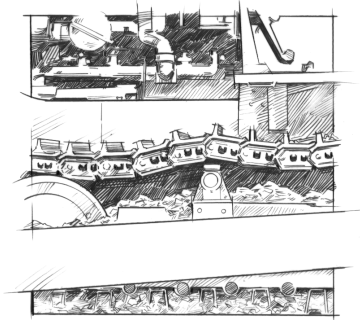

#### WARNING

**Grease is under high pressure.**

**Grease coming out of the relief valve under pressure can penetrate the body causing injury or death.**

**Do not watch the relief valve to see if grease is escaping. Watch the track or track adjustment cylinder to see if the track is being loosened.**

- 1** For proper adjustment, tractor should be in its working environment.
- 2** Move the machine forward a distance of twice its length. Allow the machine to come to a stop without the use of the brakes.

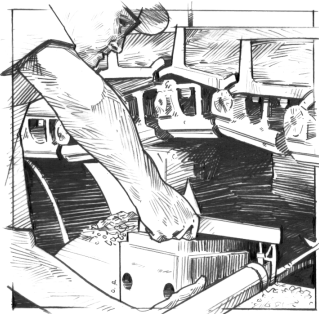

- 3** At track adjustment mechanism, connect grease gun to fitting. Extend hydraulic track adjuster until track idler is at maximum forward position. (Relief valve should remain closed.)

## Track Adjustment

---

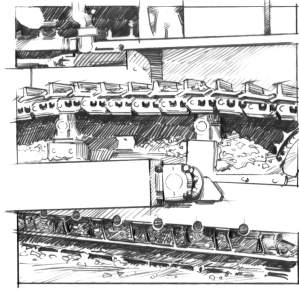

- 4** At this point, track should be almost straight between front carrier roller and idler. Do not try to squeeze any packing material from between track parts. Do not move the tractor back and forth to tighten the track.

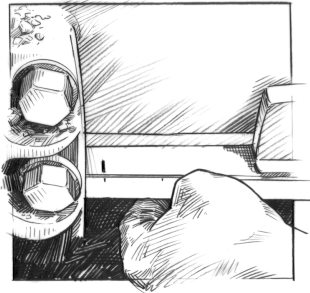

- 5** On machines with one carrier roller per side, place a mark on the track roller frame 0.4 inch or 10 millimeters behind the rear edge of the front idler bearing assembly.  
On machines with more than one carrier roller per side, mark the track roller frame 0.5 inch or 13 millimeters behind the rear edge of the assembly.

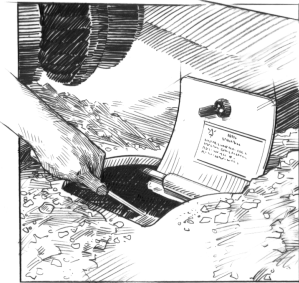

- 6** Open the hydraulic relief valve one turn maximum.  
**7** Then move the machine in reverse until idler backs up 1/2 in. (13 mm) or more.



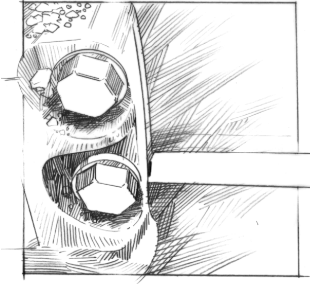

- 8** Close the hydraulic relief valve. Extend hydraulic track adjuster until the rear edge of the idler bearing assembly aligns with mark on roller frame.

**NOTE:** The resulting reference sag should be 1.75 in. to 2.00 in. (45 mm to 55 mm) on these models. Use for indication of approximate tension only.

## D7E “Electric Drive” Track Sag and Adjustment

1. Move the machine forward for a distance of two times the length of the machine. Slowly reduce the machine to zero speed with the travel control pedal. Shut off the engine.
2. Stand on the track between the front idler and the track carrier roller in order to produce as much track sag as possible.

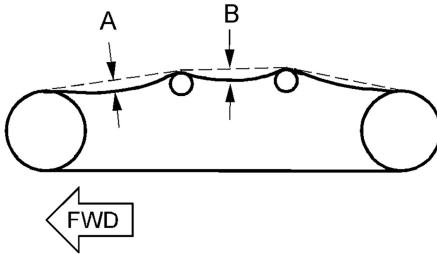

3. Measure the track sag in two places on each track.
  - a. Place a tight string or a straight edge on top of the grousers between the carrier roller and front idler. Measure distance (A) from the straight edge to the grouser tip at the lowest point of sag.
  - b. Place a tight string or a straight edge on top of the grousers between the two carrier rollers. Measure distance (B) from the straight edge to the grouser tip at the lowest point of sag.
4. Total the two measurements. The total correct adjustment of the dimensions is 50 mm (2.0 inch) to 65 mm (2.60 in).
5. Refer to Table 1 in order to determine the correct sag.

**Table 1**

<b>D7E Track Sag (Range)</b>		
<b>Location</b>	<b>D7E</b>	<b>D7E LGP</b>
Front (A)	35 mm (1.4 inch) to 45 mm (1.8 inch)	25 mm (1.0 inch) to 30 mm (1.2 inch)
Center (B)	15 mm (0.6 inch) to 20 mm (0.8 inch)	25 mm (1.0 inch) to 35 mm (1.4 inch)
Total (A + B)	50 mm (2.0 inch) to 65 mm (2.6 inch)	50 mm (2.0 inch) to 65 mm (2.6 inch)

If the track appears to be too tight or too loose, proceed to “Track Adjustment”

### Track Adjustment



Do not remove any parts until all pressure has been relieved to avoid possible personal injury. Relieve pressure by opening relief valve one turn maximum. See maintenance guide for track adjustment procedure.

1. Move the machine forward for a distance of two times the length of the machine. Slowly reduce the machine to zero speed with the travel control pedal. Shut off the engine. Adjust the tracks while you are in the typical operating conditions of the machine. If packing conditions prevail on the job, the track should be adjusted with packing material.

**Note:** Perform Steps 2 through 5 on both sides of the machine.

#### D7E

Left Track roller frame

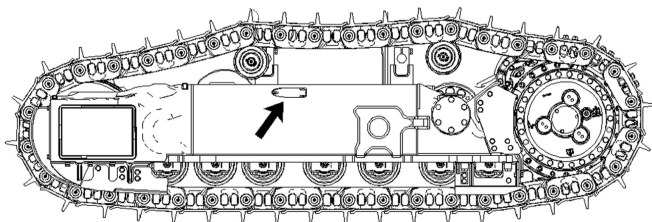

#### D7E LGP

Right track roller frame

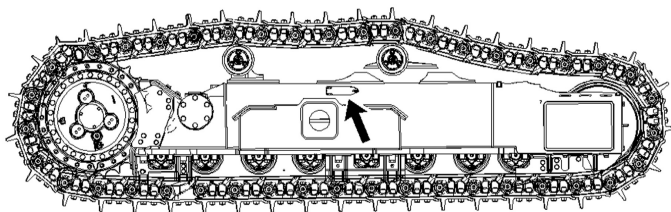

2. Remove the valve cover plate for the track adjusting mechanism.

## D7E "Electric Drive" Track Sag and Adjustment

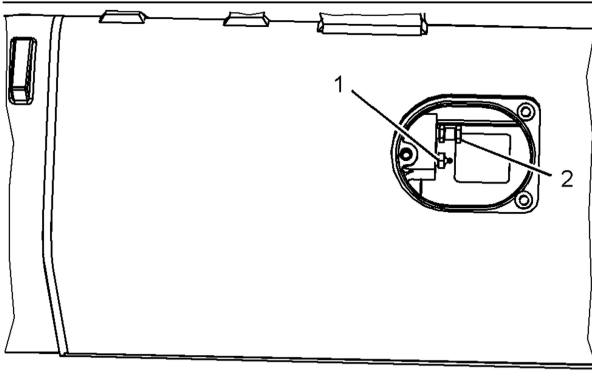

3. Add grease through track adjustment valve (1) in order to tighten the track. To loosen the track, rotate relief valve (2) counterclockwise. Then close the relief valve.
4. Set the front track sag to the dimensions in Table 2.

**Table 2**

<b>D7E Track Sag (Range)</b>		
<b>Location</b>	<b>D7E</b>	<b>D7E LGP</b>
Front (A) <sup>(1)</sup>	35 mm (1.4 inch) to 45 mm (1.8 inch)	25 mm (1.0 inch) to 30 mm (1.2 inch)
Center (B)	15 mm (0.6 inch) to 20 mm (0.8 inch)	25 mm (1.0 inch) to 35 mm (1.4 inch)
Total (A + B)	50 mm (2.0 inch) to 65 mm (2.6 inch)	50 mm (2.0 inch) to 65 mm (2.6 inch)

5. Replace the valve cover plate for the track adjusting mechanism.

---

1 Adjust the front sag on each side of the machine. Add the track sag at the front and the center for the total.

# D3C, D3G, D3K, D4C, D4G, D4K - 6.91 in. (175.5 mm)

## Track Links <sup>(1)</sup> SystemOne Track 260-6740

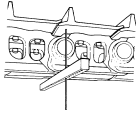

Depth Gauge			Ultrasonic	
Inches	(mm)	% Worn	Inches	(mm)
3.66	(93.0)	0	0.84	(21.3)
3.64	(92.5)	7	0.82	(20.8)
3.62	(92.0)	14	0.80	(20.3)
3.60	(91.5)	21	0.78	(19.8)
3.58	(91.0)	28	0.76	(19.3)
3.56	(90.5)	35	0.74	(18.8)
3.54	(90.0)	42	0.72	(18.3)
3.52	(89.5)	49	0.70	(17.8)
3.50	(89.0)	56	0.68	(17.3)
3.48	(88.5)	63	0.66	(16.8)
3.46	(88.0)	70	0.64	(16.3)
3.44	(87.5)	75	0.62	(15.7)
3.42	(87.0)	80	0.60	(15.2)
3.40	(86.5)	85	0.58	(14.7)
3.38	(86.0)	90	0.56	(14.2)
3.36	(85.5)	95	0.54	(13.7)
3.34	(85.0)	100	0.52	(13.2)
3.32	(84.5)	105	0.50	(12.7)
3.30	(84.0)	110	0.48	(12.2)
3.28	(83.5)	115	0.46	(11.7)
3.26	(83.0)	120	0.44	(11.2)

# D3C, D3G, D3K, D4C, D4G, D4K - 6.91 in. (175.5 mm)

## Track Links <sup>(1)</sup> SystemOne Track 233-5188

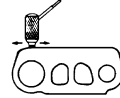
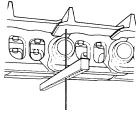

Depth Gauge			Ultrasonic	
Inches	(mm)	% Worn	Inches	(mm)
3.58	(91.0)	0	0.76	(19.3)
3.56	(90.5)	7	0.74	(18.8)
3.54	(90.0)	14	0.72	(18.3)
3.52	(89.5)	21	0.70	(17.8)
3.50	(89.0)	28	0.68	(17.3)
3.48	(88.5)	35	0.66	(16.8)
3.46	(88.0)	42	0.64	(16.3)
3.44	(87.5)	49	0.62	(15.7)
3.42	(87.0)	56	0.60	(15.2)
3.40	(86.5)	63	0.58	(14.7)
3.38	(86.0)	70	0.56	(14.2)
3.36	(85.5)	75	0.54	(13.7)
3.34	(85.0)	80	0.52	(13.2)
3.32	(84.5)	85	0.50	(12.7)
3.30	(84.0)	90	0.48	(12.2)
3.28	(83.5)	95	0.46	(11.7)
3.26	(83.0)	100	0.44	(11.2)
3.24	(82.5)	105	0.42	(10.7)
3.22	(82.0)	110	0.40	(10.2)
3.20	(81.5)	115	0.38	(9.7)
3.18	(81.0)	120	0.36	(9.1)

# D3C, D3G, D3K, D4C, D4G, D4K - 6.91 in. (175.5 mm)

## Bushings <sup>(1)</sup> External Wear SystemOne Track

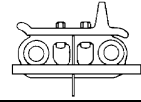
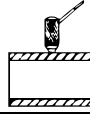

Caliper		Lesser % Worn	Ultrasonic		Depth Gauge	
Inches	(mm)		Inches	(mm)	Inches	(mm)
2.12	(53.8)	0	0.35	(8.9)	2.79	(70.9)
2.10	(53.3)	8	0.34	(8.6)	2.78	(70.6)
2.08	(52.8)	16	0.33	(8.4)	2.77	(70.4)
2.06	(52.3)	24	0.32	(8.1)	2.76	(70.1)
2.04	(51.8)	32	0.31	(7.9)	2.75	(69.9)
2.02	(51.3)	40	0.30	(7.6)	2.74	(69.6)
2.00	(50.8)	48	0.29	(7.4)	2.73	(69.3)
1.98	(50.3)	56	0.28	(7.1)	2.72	(69.1)
1.96	(49.8)	64	0.27	(6.9)	2.71	(68.8)
1.94	(49.3)	72	0.26	(6.6)	2.70	(68.6)
1.92	(48.8)	76	0.25	(6.4)	2.69	(68.3)
1.90	(48.3)	80	0.24	(6.1)	2.68	(68.1)
1.88	(47.8)	84	0.23	(5.8)	2.67	(67.8)
1.86	(47.2)	88	0.22	(5.6)	2.66	(67.6)
1.84	(46.7)	92	0.21	(5.3)	2.65	(67.3)
1.82	(46.2)	96	0.20	(5.1)	2.64	(67.1)
1.80	(45.7)	100	0.19	(4.8)	2.63	(66.8)
1.78	(45.2)	104	0.18	(4.6)	2.62	(66.5)
1.76	(44.7)	108	0.17	(4.3)	2.61	(66.3)
1.74	(44.2)	112	0.16	(4.1)	2.60	(66.0)
1.72	(43.7)	116	0.15	(3.8)	2.59	(65.8)
1.70	(43.2)	120	0.14	(3.6)	2.58	(65.5)

# D3C, D3G, D3K, D4C, D4G, D4K - 6.91 in. (175.5 mm)

## Track Shoes <sup>(1)</sup> Extreme Service SystemOne Track

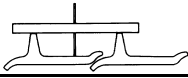

Depth Gauge			Ultrasonic	
Inches	(mm)	% Worn	Inches	(mm)
2.25	(57.0)	0	2.65	(67.2)
2.20	(56.0)	4	2.60	(65.9)
2.15	(54.5)	8	2.55	(64.7)
2.10	(53.5)	12	2.50	(63.4)
2.05	(52.0)	16	2.45	(62.1)
2.00	(51.0)	20	2.40	(60.9)
1.95	(49.5)	24	2.35	(59.6)
1.90	(48.5)	28	2.30	(58.3)
1.85	(47.0)	32	2.25	(57.0)
1.80	(45.5)	36	2.20	(55.8)
1.75	(44.5)	40	2.15	(54.5)
1.70	(43.0)	43	2.10	(53.2)
1.65	(42.0)	46	2.05	(52.0)
1.60	(40.5)	49	2.00	(50.7)
1.55	(39.5)	52	1.95	(49.4)
1.50	(38.0)	55	1.90	(48.2)
1.45	(37.0)	58	1.85	(46.9)
1.40	(35.5)	61	1.80	(45.6)
1.35	(34.5)	64	1.75	(44.3)
1.30	(33.0)	67	1.70	(43.1)
1.25	(32.0)	70	1.65	(41.8)
1.20	(30.5)	73	1.60	(40.5)
1.15	(29.0)	76	1.55	(39.3)
1.10	(28.0)	79	1.50	(38.0)
1.05	(26.5)	82	1.45	(36.7)
1.00	(25.5)	85	1.40	(35.5)
0.95	(24.0)	88	1.35	(34.2)
0.90	(23.0)	91	1.30	(32.9)
0.85	(21.5)	94	1.25	(31.6)
0.80	(20.5)	97	1.20	(30.4)
0.75	(19.0)	100	1.15	(29.1)
0.70	(18.0)	103	1.10	(27.8)
0.65	(16.5)	106	1.05	(26.6)
0.60	(15.0)	109	1.00	(25.3)
0.55	(14.0)	112	0.95	(24.0)
0.50	(12.5)	115	0.90	(22.8)
0.45	(11.5)	118	0.85	(21.5)
0.40	(10.0)	121	0.80	(20.2)



# D3C, D3G, D3K, D4C, D4G, D4K - 6.91 in. (175.5 mm)

## Track Shoes <sup>(1)</sup> Moderate Service SystemOne Track

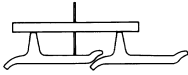

Depth Gauge			Ultrasonic	
Inches	(mm)	% Worn	Inches	(mm)
1.85	(47.0)	0	2.20	(56.0)
1.80	(45.5)	5	2.15	(54.7)
1.75	(44.5)	10	2.10	(53.5)
1.70	(43.0)	15	2.05	(52.2)
1.65	(42.0)	20	2.00	(50.9)
1.60	(40.5)	25	1.95	(49.7)
1.55	(39.5)	30	1.90	(48.4)
1.50	(38.0)	35	1.85	(47.1)
1.45	(37.0)	40	1.80	(45.8)
1.40	(35.5)	45	1.75	(44.6)
1.35	(34.5)	50	1.70	(43.3)
1.30	(33.0)	55	1.65	(42.0)
1.25	(32.0)	60	1.60	(40.8)
1.20	(30.5)	64	1.55	(39.5)
1.15	(29.0)	68	1.50	(38.2)
1.10	(28.0)	72	1.45	(37.0)
1.05	(26.5)	76	1.40	(35.7)
1.00	(25.5)	80	1.35	(34.4)
0.95	(24.0)	84	1.30	(33.1)
0.90	(23.0)	88	1.25	(31.9)
0.85	(21.5)	92	1.20	(30.6)
0.80	(20.5)	96	1.15	(29.3)
0.75	(19.0)	100	1.10	(28.1)
0.70	(18.0)	104	1.05	(26.8)
0.65	(16.5)	108	1.00	(25.5)
0.60	(15.0)	112	0.95	(24.3)
0.55	(14.0)	116	0.90	(23.0)
0.50	(12.5)	120	0.85	(21.7)

**D3C, D3G, D3K, D4C, D4G, D4K - 6.91 in. (175.5 mm)**

**Track Shoes <sup>(1)</sup>  
Self Cleaning  
SystemOne**

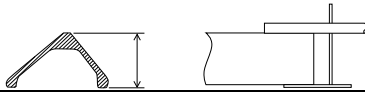

**Depth Gauge**

<b>Inches</b>	<b>(mm)</b>	<b>% Worn</b>
2.87	(73.0)	0
2.85	(72.5)	6
2.83	(72.0)	12
2.81	(71.5)	18
2.79	(71.0)	24
2.77	(70.5)	30
2.75	(70.0)	36
2.73	(69.5)	42
2.71	(69.0)	48
2.69	(68.5)	54
2.67	(68.0)	60
2.65	(67.5)	66
2.63	(67.0)	72
2.61	(66.5)	76
2.59	(66.0)	80
2.57	(65.5)	84
2.55	(65.0)	88
2.53	(64.5)	92
2.51	(64.0)	96
2.49	(63.0)	100
2.47	(62.5)	104
2.45	(62.0)	108
2.43	(61.5)	112
2.41	(61.0)	116
2.39	(60.5)	120

1 Wear Chart: 1821

## D3C, D3G, D3K, D4C, D4G, D4K - 6.91 in. (175.5 mm)

### Idlers (1) (2) (3) (4) Center Tread Idler

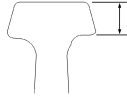

#### Ultrasonic, Depth Gauge or Caliper

Inches	(mm)	% Worn
0.98	(25.0)	0
0.96	(24.5)	5
0.94	(24.0)	10
0.92	(23.5)	15
0.90	(23.0)	20
0.88	(22.5)	25
0.86	(22.0)	30
0.84	(21.5)	34
0.82	(21.0)	37
0.80	(20.5)	40
0.78	(20.0)	43
0.76	(19.5)	46
0.74	(19.0)	49
0.72	(18.5)	52
0.70	(18.0)	55
0.68	(17.5)	58
0.66	(17.0)	61
0.64	(16.5)	64
0.62	(15.5)	67
0.60	(15.0)	70
0.58	(14.5)	73
0.56	(14.0)	76
0.54	(13.5)	79
0.52	(13.0)	82
0.50	(12.5)	85
0.48	(12.0)	88
0.46	(11.5)	91
0.44	(11.0)	94
0.42	(10.5)	97
0.40	(10.0)	100
0.38	(9.5)	103
0.36	(9.0)	106
0.34	(8.5)	109
0.32	(8.0)	112
0.30	(7.5)	115
0.28	(7.0)	118
0.26	(6.5)	121

- 1 New tread diameter (D3C, D3G, D4C, D4G) is 23.50 in. (597 mm)
- 2 New tread diameter (D3K, D4K) is 22.62 in. (574.5 mm)
- 3 For measuring instructions, reference General Information topic *Idler Wear — Center Tread Idlers on, page 51.*
- 4 Wear Chart: 4061

# D3C, D3G, D4C, D4G - 6.91 in. (175.5 mm)

Idlers <sup>(1)</sup> <sup>(2)</sup> <sup>(3)</sup>

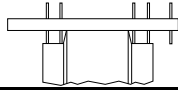

**Depth Gauge**

Inches	(mm)	% Worn
0.62	(15.5)	0
0.64	(16.5)	12
0.66	(17.0)	24
0.68	(17.5)	36
0.70	(18.0)	48
0.72	(18.5)	60
0.74	(19.0)	68
0.76	(19.5)	76
0.78	(20.0)	84
0.80	(20.5)	92
0.82	(21.0)	100
0.84	(21.5)	108
0.86	(22.0)	116
0.88	(22.5)	124

- 1 Flange width is 2.11 in. (53.5 mm)
- 2 New tread diameter is 20.28 in. (515 mm)
- 3 Wear Chart: 4320

# D3C, D3G, D3K, D4C, D4G, D4K - 6.91 in. (175.5 mm)

## Carrier Rollers <sup>(1)</sup> SystemOne Track

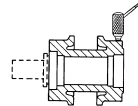
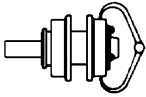

**Caliper**

**Ultrasonic**

Caliper		% Worn	Ultrasonic	
Inches	(mm)		Inches	(mm)
6.18	(157.0)	0	1.60	(40.6)
6.14	(156.0)	5	1.58	(40.1)
6.10	(155.0)	10	1.56	(39.6)
6.06	(154.0)	15	1.54	(39.1)
6.02	(153.0)	20	1.52	(38.6)
5.98	(152.0)	25	1.50	(38.1)
5.94	(151.0)	28	1.48	(37.6)
5.90	(150.0)	31	1.46	(37.1)
5.86	(149.0)	34	1.44	(36.6)
5.82	(148.0)	37	1.42	(36.1)
5.78	(147.0)	40	1.40	(35.6)
5.74	(146.0)	43	1.38	(35.1)
5.70	(145.0)	46	1.36	(34.5)
5.66	(144.0)	49	1.34	(34.0)
5.62	(142.5)	52	1.32	(33.5)
5.58	(141.5)	55	1.30	(33.0)
5.54	(140.5)	58	1.28	(32.5)
5.50	(139.5)	61	1.26	(32.0)
5.46	(138.5)	64	1.24	(31.5)
5.42	(137.5)	67	1.22	(31.0)
5.38	(136.5)	70	1.20	(30.5)
5.34	(135.5)	73	1.18	(30.0)
5.30	(134.5)	76	1.16	(29.5)
5.26	(133.5)	79	1.14	(29.0)
5.22	(132.5)	82	1.12	(28.4)
5.18	(131.5)	85	1.10	(27.9)
5.14	(130.5)	88	1.08	(27.4)
5.10	(129.5)	91	1.06	(26.9)
5.06	(128.5)	94	1.04	(26.4)
5.02	(127.5)	97	1.02	(25.9)
4.98	(126.5)	100	1.00	(25.4)
4.94	(125.5)	103	0.98	(24.9)
4.90	(124.5)	106	0.96	(24.4)
4.86	(123.5)	109	0.94	(23.9)
4.82	(122.5)	112	0.92	(23.4)
4.78	(121.5)	115	0.90	(22.9)
4.74	(120.5)	118	0.88	(22.4)
4.70	(119.5)	121	0.86	(21.8)

# D3C, D3G, D3K, D4C, D4G, D4K - 6.91 in. (175.5 mm)

## Track Rollers <sup>(1) (2)</sup> SystemOne Track Roller

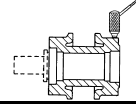

Caliper			Depth Gauge		Ultrasonic	
Inches	(mm)	% Worn	Inches	(mm)	Inches	(mm)
6.48	(164.5)	0	0.67	(17.0)	1.67	(42.4)
6.44	(163.5)	4	0.69	(17.5)	1.65	(41.9)
6.40	(162.5)	8	0.71	(18.0)	1.63	(41.4)
6.36	(161.5)	12	0.73	(18.5)	1.61	(40.9)
6.32	(160.5)	16	0.75	(19.0)	1.59	(40.4)
6.28	(159.5)	20	0.77	(19.5)	1.57	(39.9)
6.24	(158.5)	24	0.79	(20.0)	1.55	(39.4)
6.20	(157.5)	28	0.81	(20.5)	1.53	(38.9)
6.16	(156.5)	32	0.83	(21.0)	1.51	(38.4)
6.12	(155.5)	36	0.85	(21.5)	1.49	(37.8)
6.08	(154.5)	40	0.87	(22.0)	1.47	(37.3)
6.04	(153.5)	43	0.89	(22.5)	1.45	(36.8)
6.00	(152.5)	46	0.91	(23.0)	1.43	(36.3)
5.96	(151.5)	49	0.93	(23.5)	1.41	(35.8)
5.92	(150.5)	52	0.95	(24.0)	1.39	(35.3)
5.88	(149.5)	55	0.97	(24.5)	1.37	(34.8)
5.84	(148.5)	58	0.99	(25.0)	1.35	(34.3)
5.80	(147.5)	61	1.01	(25.5)	1.33	(33.8)
5.76	(146.5)	64	1.03	(26.0)	1.31	(33.3)
5.72	(145.5)	67	1.05	(26.5)	1.29	(32.8)
5.68	(144.5)	70	1.07	(27.0)	1.27	(32.3)
5.64	(143.5)	73	1.09	(27.5)	1.25	(31.8)
5.60	(142.5)	76	1.11	(28.0)	1.23	(31.2)
5.56	(141.0)	79	1.13	(28.5)	1.21	(30.7)
5.52	(140.0)	82	1.15	(29.0)	1.19	(30.2)
5.48	(139.0)	85	1.17	(29.5)	1.17	(29.7)
5.44	(138.0)	88	1.19	(30.0)	1.15	(29.2)
5.40	(137.0)	91	1.21	(30.5)	1.13	(28.7)
5.36	(136.0)	94	1.23	(31.0)	1.11	(28.2)
5.32	(135.0)	97	1.25	(32.0)	1.09	(27.7)
5.28	(134.0)	100	1.27	(32.5)	1.07	(27.2)
5.24	(133.0)	103	1.29	(33.0)	1.05	(26.7)
5.20	(132.0)	106	1.31	(33.5)	1.03	(26.2)
5.16	(131.0)	109	1.33	(34.0)	1.01	(25.7)
5.12	(130.0)	112	1.35	(34.5)	0.99	(25.1)
5.08	(129.0)	115	1.37	(35.0)	0.97	(24.6)
5.04	(128.0)	118	1.39	(35.5)	0.95	(24.1)
5.00	(127.0)	121	1.41	(36.0)	0.93	(23.6)

1 Flange diameter is 7.83 in. (198.9 mm)

2 Wear Chart: 5261

# D3C, D3G, D3K, D4C, D4G, D4K - 6.91 in. (175.5 mm)

## Track Rollers <sup>(1) (2)</sup> SystemOne Track Conventional Track Roller

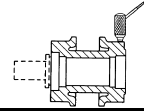
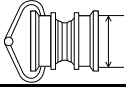

Caliper		% Worn	Depth Gauge		Ultrasonic	
Inches	(mm)		Inches	(mm)	Inches	(mm)
6.00	(152.5)	0	0.43	(11.0)	1.43	(36.3)
5.97	(151.5)	4	0.45	(11.5)	1.42	(35.9)
5.94	(151.0)	8	0.46	(11.5)	1.40	(35.6)
5.91	(150.0)	12	0.48	(12.0)	1.39	(35.2)
5.88	(149.5)	16	0.49	(12.5)	1.37	(34.8)
5.85	(148.5)	20	0.51	(13.0)	1.36	(34.4)
5.82	(148.0)	24	0.52	(13.0)	1.34	(34.0)
5.79	(147.0)	28	0.54	(13.5)	1.33	(33.7)
5.76	(146.5)	32	0.55	(14.0)	1.31	(33.3)
5.73	(145.5)	36	0.57	(14.5)	1.30	(32.9)
5.70	(145.0)	40	0.58	(14.5)	1.28	(32.5)
5.67	(144.0)	44	0.60	(15.0)	1.27	(32.1)
5.64	(143.5)	48	0.61	(15.5)	1.25	(31.8)
5.61	(142.5)	52	0.63	(16.0)	1.24	(31.4)
5.58	(141.5)	56	0.64	(16.5)	1.22	(31.0)
5.55	(141.0)	60	0.66	(16.5)	1.21	(30.6)
5.52	(140.0)	64	0.67	(17.0)	1.19	(30.2)
5.49	(139.5)	68	0.69	(17.5)	1.18	(29.8)
5.46	(138.5)	72	0.70	(18.0)	1.16	(29.5)
5.43	(138.0)	76	0.72	(18.0)	1.15	(29.1)
5.40	(137.0)	80	0.73	(18.5)	1.13	(28.7)
5.37	(136.5)	84	0.75	(19.0)	1.12	(28.3)
5.34	(135.5)	88	0.76	(19.5)	1.10	(27.9)
5.31	(135.0)	91	0.78	(19.5)	1.09	(27.6)
5.28	(134.0)	94	0.79	(20.0)	1.07	(27.2)
5.25	(133.5)	97	0.81	(20.5)	1.06	(26.8)
5.22	(132.5)	100	0.82	(21.0)	1.04	(26.4)
5.19	(132.0)	103	0.84	(21.0)	1.03	(26.0)
5.16	(131.0)	106	0.85	(21.5)	1.01	(25.7)
5.13	(130.5)	109	0.87	(22.0)	1.00	(25.3)
5.10	(129.5)	112	0.88	(22.5)	0.98	(24.9)
5.07	(129.0)	115	0.90	(22.5)	0.97	(24.5)
5.04	(128.0)	118	0.91	(23.0)	0.95	(24.1)
5.01	(127.5)	121	0.93	(23.5)	0.94	(23.7)

1 Flange diameter is 6.88 in. (174.6 mm)  
2 Wear Chart: 5222

# D3, 931, 933, 935, D4B, D4C, D4G - 6.125 in. (155.6 mm)

## Track Links <sup>(1)</sup> 6Y-0935 & 36

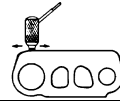
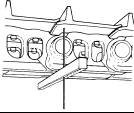

Depth Gauge			Ultrasonic	
Inches	(mm)	% Worn	Inches	(mm)
3.46	(88.0)	0	1.00	(25.4)
3.44	(87.5)	8	0.98	(24.9)
3.42	(87.0)	16	0.96	(24.4)
3.40	(86.5)	24	0.94	(23.9)
3.38	(86.0)	32	0.92	(23.4)
3.36	(85.5)	40	0.90	(22.9)
3.34	(85.0)	48	0.88	(22.4)
3.32	(84.5)	56	0.86	(21.8)
3.30	(84.0)	64	0.84	(21.3)
3.28	(83.5)	72	0.82	(20.8)
3.26	(83.0)	80	0.80	(20.3)
3.24	(82.5)	88	0.78	(19.8)
3.22	(82.0)	94	0.76	(19.3)
3.20	(81.5)	100	0.74	(18.8)
3.18	(81.0)	106	0.72	(18.3)
3.16	(80.5)	112	0.70	(17.8)
3.14	(80.0)	118	0.68	(17.3)
3.12	(79.0)	124	0.66	(16.8)



## D3, 931, 933, 935 - 6.125 in. (155.6 mm)

### Track Links <sup>(1)</sup> 6S-8343 & 44

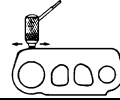
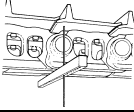

Depth Gauge			Ultrasonic		
Inches	(mm)	% Worn	Inches	(mm)	
3.30	(84.0)	0	0.92	(23.4)	
3.28	(83.5)	7	0.90	(22.9)	
3.26	(83.0)	14	0.88	(22.4)	
3.24	(82.5)	21	0.86	(21.8)	
3.22	(82.0)	28	0.84	(21.3)	
3.20	(81.5)	35	0.82	(20.8)	
3.18	(81.0)	42	0.80	(20.3)	
3.16	(80.5)	49	0.78	(19.8)	
3.14	(80.0)	56	0.76	(19.3)	
3.12	(79.0)	63	0.74	(18.8)	
3.10	(78.5)	70	0.72	(18.3)	
3.08	(78.0)	77	0.70	(17.8)	
3.06	(77.5)	84	0.68	(17.3)	
3.04	(77.0)	90	0.66	(16.8)	
3.02	(76.5)	95	0.64	(16.3)	
3.00	(76.0)	100	0.62	(15.7)	
2.98	(75.5)	105	0.60	(15.2)	
2.96	(75.0)	110	0.58	(14.7)	
2.94	(74.5)	115	0.56	(14.2)	
2.92	(74.0)	120	0.54	(13.7)	

**D3C, D3G, D4C, D4G, 931, 931B, 931C, 933C, 935B, 935C - 6.125 in. (155.6 mm)**

**Track Links <sup>(1)</sup>  
Classic  
257-7765 & 66**

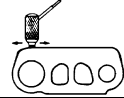
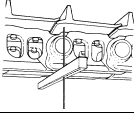

Depth Gauge			Ultrasonic	
Inches	(mm)	% Worn	Inches	(mm)
3.46	(88.0)	0	0.98	(24.9)
3.44	(87.5)	8	0.96	(24.4)
3.42	(87.0)	16	0.94	(23.9)
3.40	(86.5)	24	0.92	(23.4)
3.38	(86.0)	32	0.90	(22.9)
3.36	(85.5)	40	0.88	(22.4)
3.34	(85.0)	48	0.86	(21.8)
3.32	(84.5)	56	0.84	(21.3)
3.30	(84.0)	64	0.82	(20.8)
3.28	(83.5)	72	0.80	(20.3)
3.26	(83.0)	80	0.78	(19.8)
3.24	(82.5)	88	0.76	(19.3)
3.22	(82.0)	94	0.74	(18.8)
3.20	(81.5)	100	0.72	(18.3)
3.18	(81.0)	106	0.70	(17.8)
3.16	(80.5)	112	0.68	(17.3)
3.14	(80.0)	118	0.66	(16.8)
3.12	(79.0)	124	0.64	(16.3)

1 Wear Chart: 24

# D3, 931, 933, 935, D4B, D4C, D4G - 6.125 in. (155.6 mm)

**Bushings<sup>(1)</sup>  
Genuine and Classic  
External Wear  
Sealed & Lubricated Track  
Large Stepped Bushings**

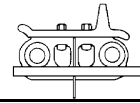
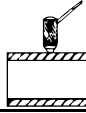
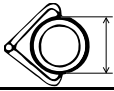

Caliper		Allowable Wear		Ultrasonic		Depth Gauge	
Inches	(mm)	Lesser % Worn	Greater % Worn	Inches	(mm)	Inches	(mm)
2.13	54.1	0	0	0.48	12.2	2.61	66.3
2.11	53.6	10	8	0.46	11.7	2.59	65.8
2.09	53.1	20	16	0.44	11.2	2.57	65.3
2.07	52.6	30	24	0.42	10.7	2.55	64.8
2.05	52.1	40	32	0.40	10.2	2.53	64.3
2.03	51.6	50	40	0.38	9.7	2.51	63.8
2.01	51.1	58	48	0.36	9.1	2.49	63.2
1.99	50.5	64	56	0.34	8.6	2.47	62.7
1.97	50.0	70	60	0.32	8.1	2.45	62.2
1.95	49.5	76	64	0.30	7.6	2.43	61.7
1.93	49.0	82	68	0.28	7.1	2.41	61.2
1.91	48.5	88	72	0.26	6.6	2.39	60.7
1.89	48.0	94	76	0.24	6.1	2.37	60.2
1.87	47.5	100	80	0.22	5.6	2.35	59.7
1.85	47.0	106	84	0.20	5.1	2.33	59.2
1.83	46.5	112	88	0.18	4.6	2.31	58.7
1.81	46.0	118	92	0.16	4.1	2.29	58.2
1.79	45.5	124	96	0.14	3.6	2.27	57.7
1.77	45.0		100	0.12	3.0	2.25	57.2
1.75	44.5		104	0.10	2.5	2.23	56.6
1.73	43.9		108	0.08	2.0	2.21	56.1
1.71	43.4		112	0.06	1.5	2.19	55.6
1.69	42.9		116	0.04	1.0	2.17	55.1
1.67	42.4		120	0.02	0.5	2.15	54.6

# D3, 931, 933, 935, D4B, D4C - 6.125 in. 155.6 mm)

## Bushings <sup>(1)</sup> External Wear Sealed & Lubricated Track Small Stepped Bushings

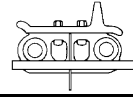
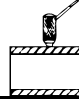
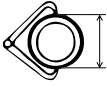

Caliper		Allowable Wear		Ultrasonic		Depth Gauge	
Inches	(mm)	Lesser % Worn	Greater % Worn	Inches	(mm)	Inches	(mm)
1.97	(50.0)	0	0	0.40	(10.2)	2.52	(64.0)
1.96	(49.8)	6	5	0.39	(9.9)	2.51	(63.8)
1.95	(49.5)	12	10	0.38	(9.7)	2.50	(63.5)
1.94	(49.3)	18	15	0.37	(9.4)	2.49	(63.2)
1.93	(49.0)	24	20	0.36	(9.1)	2.48	(63.0)
1.92	(48.8)	30	25	0.35	(8.9)	2.47	(62.7)
1.91	(48.5)	36	30	0.34	(8.6)	2.46	(62.5)
1.90	(48.3)	42	35	0.33	(8.4)	2.45	(62.2)
1.89	(48.0)	48	40	0.32	(8.1)	2.44	(62.0)
1.88	(47.8)	54	45	0.31	(7.9)	2.43	(61.7)
1.87	(47.5)	60	50	0.30	(7.6)	2.42	(61.5)
1.86	(47.2)	66	55	0.29	(7.4)	2.41	(61.2)
1.85	(47.0)	72	60	0.28	(7.1)	2.40	(61.0)
1.84	(46.7)	78	65	0.27	(6.9)	2.39	(60.7)
1.83	(46.5)	84	70	0.26	(6.6)	2.38	(60.5)
1.82	(46.2)	88	72	0.25	(6.4)	2.37	(60.2)
1.81	(46.0)	91	74	0.24	(6.1)	2.36	(59.9)
1.80	(45.7)	94	76	0.23	(5.8)	2.35	(59.7)
1.79	(45.5)	97	78	0.22	(5.6)	2.34	(59.4)
1.78	(45.2)	100	80	0.21	(5.3)	2.33	(59.2)
1.77	(45.0)	103	82	0.20	(5.1)	2.32	(58.9)
1.76	(44.7)	106	84	0.19	(4.8)	2.31	(58.7)
1.75	(44.5)	109	86	0.18	(4.6)	2.30	(58.4)
1.74	(44.2)	112	88	0.17	(4.3)	2.29	(58.2)
1.73	(43.9)	115	90	0.16	(4.1)	2.28	(57.9)
1.72	(43.7)	118	92	0.15	(3.8)	2.27	(57.7)
1.71	(43.4)	121	94	0.14	(3.6)	2.26	(57.4)
1.70	(43.2)		96	0.13	(3.3)	2.25	(57.2)
1.69	(42.9)		98	0.12	(3.0)	2.24	(56.9)
1.68	(42.7)		100	0.11	(2.8)	2.23	(56.6)
1.67	(42.4)		102	0.10	(2.5)	2.22	(56.4)
1.66	(42.2)		104	0.09	(2.3)	2.21	(56.1)
1.65	(41.9)		106	0.08	(2.0)	2.20	(55.9)
1.64	(41.7)		108	0.07	(1.8)	2.19	(55.6)
1.63	(41.4)		110	0.06	(1.5)	2.18	(55.4)
1.62	(41.1)		112	0.05	(1.3)	2.17	(55.1)
1.61	(40.9)		114	0.04	(1.0)	2.16	(54.9)
1.60	(40.6)		116	0.03	(0.8)	2.15	(54.6)
1.59	(40.4)		118	0.02	(0.5)	2.14	(54.4)
1.58	(40.1)		120	0.01	(0.3)	2.13	(54.1)

1 Wear Chart: 621

**Bushings<sup>(1)</sup>  
External Wear  
Sealed & Lubricated Track  
Straight Bushings**

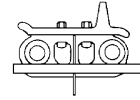
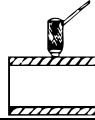
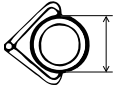

Caliper		Allowable Wear		Ultrasonic		Depth Gauge	
Inches	(mm)	Lesser % Worn	Greater % Worn	Inches	(mm)	Inches	(mm)
1.85	(47.0)	0	0	0.34	(8.6)	2.39	(60.7)
1.84	(46.7)	8	6	0.33	(8.4)	2.38	(60.5)
1.83	(46.5)	16	12	0.32	(8.1)	2.37	(60.2)
1.82	(46.2)	24	18	0.31	(7.9)	2.36	(59.9)
1.81	(46.0)	32	24	0.30	(7.6)	2.35	(59.7)
1.80	(45.7)	40	30	0.29	(7.4)	2.34	(59.4)
1.79	(45.5)	48	36	0.28	(7.1)	2.33	(59.2)
1.78	(45.2)	56	42	0.27	(6.9)	2.32	(58.9)
1.77	(45.0)	64	48	0.26	(6.6)	2.31	(58.7)
1.76	(44.7)	72	54	0.25	(6.4)	2.30	(58.4)
1.75	(44.5)	80	60	0.24	(6.1)	2.29	(58.2)
1.74	(44.2)	88	66	0.23	(5.8)	2.28	(57.9)
1.73	(43.9)	96	72	0.22	(5.6)	2.27	(57.7)
1.72	(43.7)	100	78	0.21	(5.3)	2.26	(57.4)
1.71	(43.4)	103	82	0.20	(5.1)	2.25	(57.2)
1.70	(43.2)	106	84	0.19	(4.8)	2.24	(56.9)
1.69	(42.9)	109	86	0.18	(4.6)	2.23	(56.6)
1.68	(42.7)	112	88	0.17	(4.3)	2.22	(56.4)
1.67	(42.4)	115	90	0.16	(4.1)	2.21	(56.1)
1.66	(42.2)	118	92	0.15	(3.8)	2.20	(55.9)
1.165	(41.9)	121	94	0.14	(3.6)	2.19	(55.6)
.64	(41.7)		96	0.13	(3.3)	2.18	(55.4)
1.63	(41.4)		98	0.12	(3.0)	2.17	(55.1)
1.62	(41.1)		100	0.11	(2.8)	2.16	(54.9)
1.61	(40.9)		102	0.10	(2.5)	2.15	(54.6)
1.60	(40.6)		104	0.09	(2.3)	2.14	(54.4)
1.59	(40.4)		106	0.08	(2.0)	2.13	(54.1)
1.58	(40.1)		108	0.07	(1.8)	2.12	(53.8)
1.57	(39.9)		110	0.06	(1.5)	2.11	(53.6)
1.56	(39.6)		112	0.05	(1.3)	2.10	(53.3)
1.55	(39.4)		114	0.04	(1.0)	2.09	(53.1)
1.54	(39.1)		116	0.03	(0.8)	2.08	(52.8)
1.53	(38.9)		118	0.02	(0.5)	2.07	(52.6)
1.52	(38.6)		120	0.01	(0.3)	2.06	(52.3)

**D3, 931, 933, D4B, D4C, D4G - 6.125 in. (155.6 mm)**

**Pins and Bushings <sup>(1)</sup>  
Genuine and Classic  
Internal Wear  
Sealed Track**

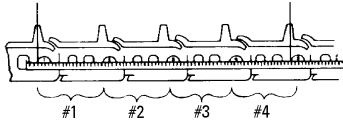

<b>Caliper</b>		
<b>Inches</b>	<b>(mm)</b>	<b>% Worn</b>
24.55	(623.5)	0
24.60	(625.0)	10
24.65	(626.0)	20
24.70	(627.5)	30
24.75	(628.5)	40
24.80	(630.0)	50
24.85	(631.0)	60
24.90	(632.5)	70
24.95	(633.5)	80
25.00	(635.0)	90
25.05	(636.5)	100
25.10	(637.5)	105
25.15	(639.0)	110
25.20	(640.0)	115
25.25	(641.5)	120

1 Wear Chart: 320

# D3, 931, 933, 935, D4B, D4C, D4G - 6.125 in. (155.6 mm)

## Bushings <sup>(1)</sup> Genuine and Classic External Wear Sealed Track Stepped Bushings

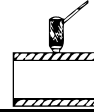
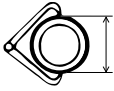

Caliper		Allowable Wear		Ultrasonic	
Inches	(mm)	Lesser % Worn	Greater % Worn	Inches	(mm)
1.97	(50.0)	0	0	0.40	(10.2)
1.96	(49.8)	8	6	0.39	(9.9)
1.95	(49.5)	16	12	0.38	(9.7)
1.94	(49.3)	24	18	0.37	(9.4)
1.93	(49.0)	32	24	0.36	(9.1)
1.92	(48.8)	40	30	0.35	(8.9)
1.91	(48.5)	48	36	0.34	(8.6)
1.90	(48.3)	56	42	0.33	(8.4)
1.89	(48.0)	64	48	0.32	(8.1)
1.88	(47.8)	72	54	0.31	(7.9)
1.87	(47.5)	76	60	0.30	(7.6)
1.86	(47.2)	80	64	0.29	(7.4)
1.85	(47.0)	84	67	0.28	(7.1)
1.84	(46.7)	88	70	0.27	(6.9)
1.83	(46.5)	92	73	0.26	(6.6)
1.82	(46.2)	96	76	0.25	(6.4)
1.81	(46.0)	100	79	0.24	(6.1)
1.80	(45.7)	104	82	0.23	(5.8)
1.79	(45.5)	108	85	0.22	(5.6)
1.78	(45.2)	112	88	0.21	(5.3)
1.77	(45.0)	116	91	0.20	(5.1)
1.76	(44.7)	120	94	0.19	(4.8)
1.75	(44.5)		97	0.18	(4.6)
1.74	(44.2)		100	0.17	(4.3)
1.73	(43.9)		103	0.16	(4.1)
1.72	(43.7)		106	0.15	(3.8)
1.71	(43.4)		109	0.14	(3.6)
1.70	(43.2)		112	0.13	(3.3)
1.69	(42.9)		115	0.12	(3.0)
1.68	(42.7)		118	0.11	(2.8)
1.67	(42.4)		121	0.10	(2.5)

# D3, 931, 935 - 6.125 in. (155.6 mm)

## Bushings <sup>(1)</sup> External Wear Sealed Track Straight Bushings

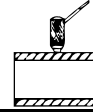

Caliper		Allowable Wear		Ultrasonic	
Inches	(mm)	Lesser % Worn	Greater % Worn	Inches	(mm)
1.85	(47.0)	0	0	0.35	(8.9)
1.84	(46.7)	10	7	0.34	(8.6)
1.83	(46.5)	20	14	0.33	(8.4)
1.82	(46.2)	30	21	0.32	(8.1)
1.81	(46.0)	40	28	0.31	(7.9)
1.80	(45.7)	50	35	0.30	(7.6)
1.79	(45.5)	60	42	0.29	(7.4)
1.78	(45.2)	70	49	0.28	(7.1)
1.77	(45.0)	80	56	0.27	(6.9)
1.76	(44.7)	90	63	0.26	(6.6)
1.75	(44.5)	96	70	0.25	(6.4)
1.74	(44.2)	100	77	0.24	(6.1)
1.73	(43.9)	104	82	0.23	(5.8)
1.72	(43.7)	108	85	0.22	(5.6)
1.71	(43.4)	112	88	0.21	(5.3)
1.70	(43.2)	116	91	0.20	(5.1)
1.69	(42.9)	120	94	0.19	(4.8)
1.68	(42.7)		97	0.18	(4.6)
1.67	(42.4)		100	0.17	(4.3)
1.66	(42.2)		103	0.16	(4.1)
1.65	(41.9)		106	0.15	(3.8)
1.64	(41.7)		109	0.14	(3.6)
1.63	(41.4)		112	0.13	(3.3)
1.62	(41.1)		115	0.12	(3.0)
1.61	(40.9)		118	0.11	(2.8)
1.60	(40.6)		121	0.10	(2.5)



# D3, 931, 933, 935, D4B, D4C, D4G - 6.125 in. (155.6 mm)

## Track Shoes <sup>(1)</sup> Extreme Service

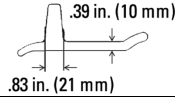
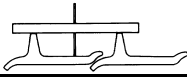

**Depth Gauge**

**Ultrasonic**

Inches	(mm)	% Worn	Inches	(mm)
2.10	(53.5)	0	2.50	(63.5)
2.05	(52.0)	4	2.45	(62.2)
2.00	(51.0)	8	2.40	(61.0)
1.95	(49.5)	12	2.35	(59.7)
1.90	(48.5)	16	2.30	(58.4)
1.85	(47.0)	20	2.25	(57.2)
1.80	(45.5)	24	2.20	(55.9)
1.75	(44.5)	28	2.15	(54.6)
1.70	(43.0)	32	2.10	(53.3)
1.65	(42.0)	36	2.05	(52.1)
1.60	(40.5)	40	2.00	(50.8)
1.55	(39.5)	44	1.95	(49.5)
1.50	(38.0)	48	1.90	(48.3)
1.45	(37.0)	52	1.85	(47.0)
1.40	(35.5)	56	1.80	(45.7)
1.35	(34.5)	60	1.75	(44.5)
1.30	(33.0)	64	1.70	(43.2)
1.25	(32.0)	68	1.65	(41.9)
1.20	(30.5)	72	1.60	(40.6)
1.15	(29.0)	76	1.55	(39.4)
1.10	(28.0)	79	1.50	(38.1)
1.05	(26.5)	82	1.45	(36.8)
1.00	(25.5)	85	1.40	(35.6)
0.95	(24.0)	88	1.35	(34.3)
0.90	(23.0)	91	1.30	(33.0)
0.85	(21.5)	94	1.25	(31.8)
0.80	(20.5)	97	1.20	(30.5)
0.75	(19.0)	100	1.15	(29.2)
0.70	(18.0)	103	1.10	(27.9)
0.65	(16.5)	106	1.05	(26.7)
0.60	(15.0)	109	1.00	(25.4)
0.55	(14.0)	112	0.95	(24.1)
0.50	(12.5)	115	0.90	(22.9)
0.45	(11.5)	118	0.85	(21.6)
0.40	(10.0)	121	0.80	(20.3)

# D3, 931, 933, 935, D4B, D4C, D4G - 6.125 in. (155.6 mm)

## Track Shoes <sup>(1)</sup> Genuine and Classic Moderate Service

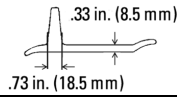
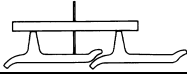

### Depth Gauge

### Ultrasonic

Inches	(mm)	% Worn	Inches	(mm)
1.85	(47.0)	0	2.20	(55.9)
1.80	(45.5)	5	2.15	(54.6)
1.75	(44.5)	10	2.10	(53.3)
1.70	(43.0)	15	2.05	(52.1)
1.65	(42.0)	20	2.00	(50.8)
1.60	(40.5)	25	1.95	(49.5)
1.55	(39.5)	30	1.90	(48.3)
1.50	(38.0)	35	1.85	(47.0)
1.45	(37.0)	40	1.80	(45.7)
1.40	(35.5)	45	1.75	(44.5)
1.35	(34.5)	50	1.70	(43.2)
1.30	(33.0)	55	1.65	(41.9)
1.25	(32.0)	60	1.60	(40.6)
1.20	(30.5)	64	1.55	(39.4)
1.15	(29.0)	68	1.50	(38.1)
1.10	(28.0)	72	1.45	(36.8)
1.05	(26.5)	76	1.40	(35.6)
1.00	(25.5)	80	1.35	(34.3)
0.95	(24.0)	84	1.30	(33.0)
0.90	(23.0)	88	1.25	(31.8)
0.85	(21.5)	92	1.20	(30.5)
0.80	(20.5)	96	1.15	(29.2)
0.75	(19.0)	100	1.10	(27.9)
0.70	(18.0)	104	1.05	(26.7)
0.65	(16.5)	108	1.00	(25.4)
0.60	(15.0)	112	0.95	(24.1)
0.55	(14.0)	116	0.90	(22.9)
0.50	(12.5)	120	0.85	(21.6)

## D3, 931, 933, 935, D4B, D4C, D4G - 6.125 in. (155.6 mm)

### Track Shoes <sup>(1)</sup> Genuine and Classic Double Grouser

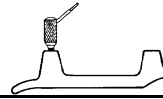
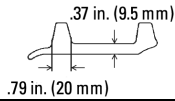
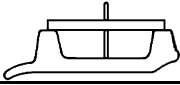

#### Depth Gauge

#### Ultrasonic

Inches	(mm)	% Worn	Inches	(mm)
1.15	(29.0)	0	1.50	(38.1)
1.10	(28.0)	8	1.45	(36.8)
1.05	(26.5)	16	1.40	(35.6)
1.00	(25.5)	24	1.35	(34.3)
0.95	(24.0)	32	1.30	(33.0)
0.90	(23.0)	40	1.25	(31.8)
0.85	(21.5)	48	1.20	(30.5)
0.80	(20.5)	56	1.15	(29.2)
0.75	(19.0)	64	1.10	(27.9)
0.70	(18.0)	72	1.05	(26.7)
0.65	(16.5)	79	1.00	(25.4)
0.60	(15.0)	86	0.95	(24.1)
0.55	(14.0)	93	0.90	(22.9)
0.50	(12.5)	100	0.85	(21.6)
0.45	(11.5)	107	0.80	(20.3)
0.40	(10.0)	114	0.75	(19.1)
0.35	(9.0)	121	0.70	(17.8)

**D3, 931, 933, 935, D4B, D4C, D4G - 6.125 in. (155.6 mm)**

**Track Shoes <sup>(1)</sup>  
Genuine and Classic  
Triple Grouser**

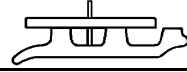
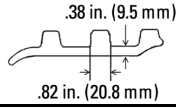
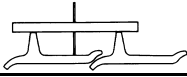

**Depth Gauge**

**Ultrasonic**

<b>Inches</b>	<b>(mm)</b>	<b>% Worn</b>	<b>Inches</b>	<b>(mm)</b>
0.60	(15.0)	0	1.00	(25.4)
0.55	(14.0)	15	0.95	(24.1)
0.50	(12.5)	30	0.90	(22.9)
0.45	(11.5)	44	0.85	(21.6)
0.40	(10.0)	58	0.80	(20.3)
0.35	(9.0)	72	0.75	(19.1)
0.30	(7.5)	86	0.70	(17.8)
0.25	(6.5)	100	0.65	(16.5)
0.20	(5.0)	114	0.60	(15.2)
0.15	(4.0)	128	0.55	(14.0)

**D3, 931, 933, 935, D4B, D4C, D4G - 6.125 in. (155.6 mm)**

**Track Shoes <sup>(1)</sup>  
Self Cleaning**



**Depth Gauge**

<b>Inches</b>	<b>(mm)</b>	<b>% Worn</b>
3.02	(76.5)	0
3.00	(76.0)	6
2.98	(75.5)	12
2.96	(75.0)	18
2.94	(74.5)	24
2.92	(74.0)	30
2.90	(73.5)	36
2.88	(73.0)	42
2.86	(72.5)	48
2.84	(72.0)	54
2.82	(71.5)	60
2.80	(71.0)	66
2.78	(70.5)	72
2.76	(70.0)	76
2.74	(69.5)	80
2.72	(69.0)	84
2.70	(68.5)	88
2.68	(68.0)	92
2.66	(67.5)	96
2.64	(67.0)	100
2.62	(66.5)	104
2.60	(66.0)	108
2.58	(65.5)	112
2.56	(65.0)	116
2.54	(64.5)	120

## D3, 931, 933, 935, D4B, D4C, D4G - 6.125 in. (155.6 mm)

### Idlers <sup>(1)</sup> <sup>(2)</sup> <sup>(3)</sup> Genuine and Classic

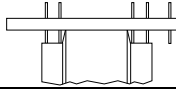

#### Depth Gauge

Inches	(mm)	% Worn
0.62	(15.5)	0
0.64	(16.5)	12
0.66	(17.0)	24
0.68	(17.5)	36
0.70	(18.0)	48
0.72	(18.5)	60
0.74	(19.0)	68
0.76	(19.5)	76
0.78	(20.0)	84
0.80	(20.5)	92
0.82	(21.0)	100
0.84	(21.5)	108
0.86	(22.0)	116
0.88	(22.5)	124

#### NOTE

On earlier, single web idlers the manufacturing process erroneously permitted a crowned center flange. When measuring earlier, single web idlers with a crown, subtract .10 in. (2.4 mm) from the actual wear measurement when determining percent worn. Reference: IRM UC92-23.

- 1 Flange width is 2.11 in. (53.5 mm)
- 2 New tread diameter is 20.28 in. (515 mm)
- 3 Wear Chart: 4320

# D3, 931, 933, 935, D4B, D4C, D4G - 6.125 in. (155.6 mm)

## Carrier Rollers <sup>(1)</sup>

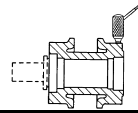
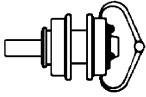

Caliper			Ultrasonic	
Inches	(mm)	% Worn	Inches	(mm)
5.88	(149.5)	0	1.38	(35.1)
5.84	(148.5)	6	1.36	(34.5)
5.80	(147.5)	12	1.34	(34.0)
5.76	(146.5)	18	1.32	(33.5)
5.72	(145.5)	24	1.30	(33.0)
5.68	(144.5)	30	1.28	(32.5)
5.64	(143.5)	36	1.26	(32.0)
5.60	(142.0)	42	1.24	(31.5)
5.56	(141.0)	48	1.22	(31.0)
5.52	(140.0)	54	1.20	(30.5)
5.48	(139.0)	60	1.18	(30.0)
5.44	(138.0)	66	1.16	(29.5)
5.40	(137.0)	72	1.14	(29.0)
5.36	(136.0)	78	1.12	(28.4)
5.32	(135.0)	84	1.10	(27.9)
5.28	(134.0)	90	1.08	(27.4)
5.24	(133.0)	96	1.06	(26.9)
5.20	(132.0)	100	1.04	(26.4)
5.16	(131.0)	104	1.02	(25.9)
5.12	(130.0)	108	1.00	(25.4)
5.08	(129.0)	112	0.98	(24.9)
5.04	(128.0)	116	0.96	(24.4)
5.00	(127.0)	120	0.94	(23.9)

# D3, 931, 933, 935, D4B, D4C, D4G - 6.125 in. (155.6 mm)

## Track Rollers <sup>(1)</sup> <sup>(2)</sup>

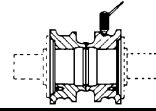
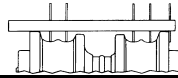
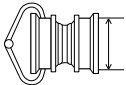

Caliper			Depth Gauge		Ultrasonic	
Inches	(mm)	% Worn	Inches	(mm)	Inches	(mm)
6.00	(152.5)	0	0.43	(11.0)	1.43	(36.3)
5.97	(151.5)	4	0.45	(11.5)	1.42	(35.9)
5.94	(151.0)	8	0.46	(11.5)	1.40	(35.6)
5.91	(150.0)	12	0.48	(12.0)	1.39	(35.2)
5.88	(149.5)	16	0.49	(12.5)	1.37	(34.8)
5.85	(148.5)	20	0.51	(13.0)	1.36	(34.4)
5.82	(148.0)	24	0.52	(13.0)	1.34	(34.0)
5.79	(147.0)	28	0.54	(13.5)	1.33	(33.7)
5.76	(146.5)	32	0.55	(14.0)	1.31	(33.3)
5.73	(145.5)	36	0.57	(14.5)	1.30	(32.9)
5.70	(145.0)	40	0.58	(14.5)	1.28	(32.5)
5.67	(144.0)	44	0.60	(15.0)	1.27	(32.1)
5.64	(143.5)	48	0.61	(15.5)	1.25	(31.8)
5.61	(142.5)	52	0.63	(16.0)	1.24	(31.4)
5.58	(141.5)	56	0.64	(16.5)	1.22	(31.0)
5.55	(141.0)	60	0.66	(16.5)	1.21	(30.6)
5.52	(140.0)	64	0.67	(17.0)	1.19	(30.2)
5.49	(139.5)	68	0.69	(17.5)	1.18	(29.8)
5.46	(138.5)	72	0.70	(18.0)	1.16	(29.5)
5.43	(138.0)	76	0.72	(18.0)	1.15	(29.1)
5.40	(137.0)	80	0.73	(18.5)	1.13	(28.7)
5.37	(136.5)	84	0.75	(19.0)	1.12	(28.3)
5.34	(135.5)	88	0.76	(19.5)	1.10	(27.9)
5.31	(135.0)	91	0.78	(19.5)	1.09	(27.6)
5.28	(134.0)	94	0.79	(20.0)	1.07	(27.2)
5.25	(133.5)	97	0.81	(20.5)	1.06	(26.8)
5.22	(132.5)	100	0.82	(21.0)	1.04	(26.4)
5.19	(132.0)	103	0.84	(21.0)	1.03	(26.0)
5.16	(131.0)	106	0.85	(21.5)	1.01	(25.7)
5.13	(130.5)	109	0.87	(22.0)	1.00	(25.3)
5.10	(129.5)	112	0.88	(22.5)	0.98	(24.9)
5.07	(129.0)	115	0.90	(22.5)	0.97	(24.5)
5.04	(128.0)	118	0.91	(23.0)	0.95	(24.1)
5.01	(127.5)	121	0.93	(23.5)	0.94	(23.7)

1 Flange diameter is 6.88 in. (175 mm)

2 Wear Chart: 5222



Track Links <sup>(1)</sup>  
 9K-6628 & 29  
 7K-1825 & 26

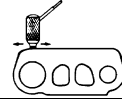
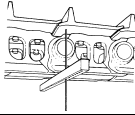

Depth Gauge			Ultrasonic	
Inches	(mm)	% Worn	Inches	(mm)
3.75	(95.5)	0	1.00	(25.4)
3.73	(94.5)	8	0.98	(24.9)
3.71	(94.0)	16	0.96	(24.4)
3.69	(93.5)	24	0.94	(23.9)
3.67	(93.0)	32	0.92	(23.4)
3.65	(92.5)	40	0.90	(22.9)
3.63	(92.0)	46	0.88	(22.4)
3.61	(91.5)	52	0.86	(21.8)
3.59	(91.0)	58	0.84	(21.3)
3.57	(90.5)	64	0.82	(20.8)
3.55	(90.0)	70	0.80	(20.3)
3.53	(89.5)	76	0.78	(19.8)
3.51	(89.0)	82	0.76	(19.3)
3.49	(88.5)	88	0.74	(18.8)
3.47	(88.0)	94	0.72	(18.3)
3.45	(87.5)	100	0.70	(17.8)
3.43	(87.0)	106	0.68	(17.3)
3.41	(86.5)	112	0.66	(16.8)
3.39	(86.0)	118	0.64	(16.3)
3.37	(85.5)	124	0.62	(15.7)

# D4, 941 - 6.75 in. (171.5 mm)

**Track Links <sup>(1)</sup>**  
**5K-9423 & 24**  
**5K-9457 & 58**

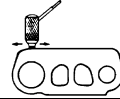
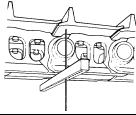

Depth Gauge			Ultrasonic	
Inches	(mm)	% Worn	Inches	(mm)
3.65	(92.5)	0	1.07	(27.2)
3.63	(92.0)	7	1.05	(26.7)
3.61	(91.5)	14	1.03	(26.2)
3.59	(91.0)	21	1.01	(25.7)
3.57	(90.5)	28	0.99	(25.1)
3.55	(90.0)	35	0.97	(24.6)
3.53	(89.5)	42	0.95	(24.1)
3.51	(89.0)	49	0.93	(23.6)
3.49	(88.5)	56	0.91	(23.1)
3.47	(88.0)	63	0.89	(22.6)
3.45	(87.5)	70	0.87	(22.1)
3.43	(87.0)	75	0.85	(21.6)
3.41	(86.5)	80	0.83	(21.1)
3.39	(86.0)	85	0.81	(20.6)
3.37	(85.5)	90	0.79	(20.1)
3.35	(85.0)	95	0.77	(19.6)
3.33	(84.5)	100	0.75	(19.1)
3.31	(84.0)	105	0.73	(18.5)
3.29	(83.5)	110	0.71	(18.0)
3.27	(83.0)	115	0.69	(17.5)
3.25	(82.5)	120	0.67	(17.0)

**Bushings <sup>(1)</sup>  
External Wear  
Sealed & Lubricated Track**

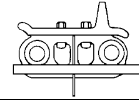
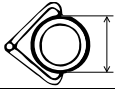

Caliper		Allowable Wear				Depth Gauge	
		Lesser	Greater	Ultrasonic			
Inches	(mm)	% Worn	% Worn	Inches	(mm)	Inches	(mm)
2.24	(56.9)	0	0	0.44	(11.2)	2.81	(71.4)
2.22	(56.4)	12	10	0.42	(10.7)	2.79	(70.9)
2.20	(55.9)	24	20	0.40	(10.2)	2.77	(70.4)
2.18	(55.4)	36	30	0.38	(9.7)	2.75	(69.9)
2.16	(54.9)	48	40	0.36	(9.1)	2.73	(69.3)
2.14	(54.4)	60	50	0.34	(8.6)	2.71	(68.8)
2.12	(53.8)	70	60	0.32	(8.1)	2.69	(68.3)
2.10	(53.3)	76	64	0.30	(7.6)	2.67	(67.8)
2.08	(52.8)	82	68	0.28	(7.1)	2.65	(67.3)
2.06	(52.3)	88	72	0.26	(6.6)	2.63	(66.8)
2.04	(51.8)	94	76	0.24	(6.1)	2.61	(66.3)
2.02	(51.3)	100	80	0.22	(5.6)	2.59	(65.8)
2.00	(50.8)	106	84	0.20	(5.1)	2.57	(65.3)
1.98	(50.3)	112	88	0.18	(4.6)	2.55	(64.8)
1.96	(49.8)	118	92	0.16	(4.1)	2.53	(64.3)
1.94	(49.3)	124	96	0.14	(3.6)	2.51	(63.8)
1.92	(48.8)		100	0.12	(3.0)	2.49	(63.2)
1.90	(48.3)		104	0.10	(2.5)	2.47	(62.7)
1.88	(47.8)		108	0.08	(2.0)	2.45	(62.2)
1.86	(47.2)		112	0.06	(1.5)	2.43	(61.7)
1.84	(46.7)		116	0.04	(1.0)	2.41	(61.2)
1.82	(46.2)		120	0.02	(0.5)	2.39	(60.7)

**D4, 941 - 6.75 in. (171.5 mm)**

**Pins and Bushings <sup>(1)</sup>  
Internal Wear  
Sealed Track**

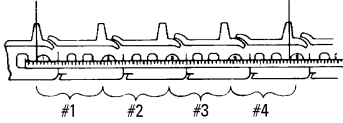

Inches	(mm)	% Worn
27.00	(686.0)	0
27.05	(687.0)	10
27.10	(688.5)	20
27.15	(689.5)	30
27.20	(691.0)	40
27.25	(692.0)	50
27.30	(693.5)	60
27.35	(694.5)	70
27.40	(696.0)	80
27.45	(697.0)	90
27.50	(698.5)	100
27.55	(700.0)	105
27.60	(701.0)	110
27.65	(702.5)	115
27.70	(703.5)	120

1 Wear Chart: 340

**Bushings <sup>(1)</sup>  
External Wear  
Sealed Track  
Use with 7K and 9K Links**

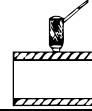

**Allowable Wear**

Caliper		Lesser	Greater	Ultrasonic	
Inches	(mm)	% Worn	% Worn	Inches	(mm)
2.14	(54.4)	0	0	0.39	(9.9)
2.13	(54.1)	9	7	0.38	(9.7)
2.12	(53.8)	18	14	0.37	(9.4)
2.11	(53.6)	27	21	0.36	(9.1)
2.10	(53.3)	36	28	0.35	(8.9)
2.09	(53.1)	45	35	0.34	(8.6)
2.08	(52.8)	54	42	0.33	(8.4)
2.07	(52.6)	63	49	0.32	(8.1)
2.06	(52.3)	72	56	0.31	(7.9)
2.05	(52.1)	81	63	0.30	(7.6)
2.04	(51.8)	88	70	0.29	(7.4)
2.03	(51.6)	92	73	0.28	(7.1)
2.02	(51.3)	96	76	0.27	(6.9)
2.01	(51.1)	100	79	0.26	(6.6)
2.00	(50.8)	104	82	0.25	(6.4)
1.99	(50.5)	108	85	0.24	(6.1)
1.98	(50.3)	112	88	0.23	(5.8)
1.97	(50.0)	116	91	0.22	(5.6)
1.96	(49.8)	120	94	0.21	(5.3)
1.95	(49.5)		97	0.20	(5.1)
1.94	(49.3)		100	0.19	(4.8)
1.93	(49.0)		103	0.18	(4.6)
1.92	(48.8)		106	0.17	(4.3)
1.91	(48.5)		109	0.16	(4.1)
1.90	(48.3)		112	0.15	(3.8)
1.89	(48.0)		115	0.14	(3.6)
1.88	(47.8)		118	0.13	(3.3)
1.87	(47.5)		121	0.12	(3.0)

# D4, 941 - 6.75 in. (171.5 mm)

**Bushings <sup>(1)</sup>**  
**External Wear**  
**Sealed Track**  
**Use with 5K Links**

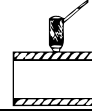

Caliper		Allowable Wear		Ultrasonic	
Inches	(mm)	Lesser % Worn	Greater % Worn	Inches	(mm)
2.01	(51.1)	0	0	0.33	(8.4)
2.00	(50.8)	9	7	0.32	(8.1)
1.99	(50.5)	18	14	0.31	(7.9)
1.98	(50.3)	27	21	0.30	(7.6)
1.97	(50.0)	36	28	0.29	(7.4)
1.96	(49.8)	45	35	0.28	(7.1)
1.95	(49.5)	54	42	0.27	(6.9)
1.94	(49.3)	63	49	0.26	(6.6)
1.93	(49.0)	72	56	0.25	(6.4)
1.92	(48.8)	81	63	0.24	(6.1)
1.91	(48.5)	88	70	0.23	(5.8)
1.90	(48.3)	92	73	0.22	(5.6)
1.89	(48.0)	96	76	0.21	(5.3)
1.88	(47.8)	100	79	0.20	(5.1)
1.87	(47.5)	104	82	0.19	(4.8)
1.86	(47.2)	108	85	0.18	(4.6)
1.85	(47.0)	112	88	0.17	(4.3)
1.84	(46.7)	116	91	0.16	(4.1)
1.83	(46.5)	120	94	0.15	(3.8)
1.82	(46.2)		97	0.14	(3.6)
1.81	(46.0)		100	0.13	(3.3)
1.80	(45.7)		103	0.12	(3.0)
1.79	(45.5)		106	0.11	(2.8)
1.78	(45.2)		109	0.10	(2.5)
1.77	(45.0)		112	0.09	(2.3)
1.76	(44.7)		115	0.08	(2.0)
1.75	(44.5)		118	0.07	(1.8)
1.74	(44.2)		121	0.06	(1.5)

**Track Shoes <sup>(1)</sup>  
Extreme Service**

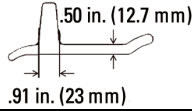
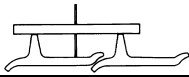

**Depth Gauge**

**Ultrasonic**

Inches	(mm)	% Worn	Inches	(mm)
2.25	(57.0)	0	2.75	(69.9)
2.20	(56.0)	4	2.70	(68.6)
2.15	(54.5)	8	2.65	(67.4)
2.10	(53.5)	12	2.60	(66.1)
2.05	(52.0)	16	2.55	(64.8)
2.00	(51.0)	20	2.50	(63.6)
1.95	(49.5)	24	2.45	(62.3)
1.90	(48.5)	28	2.40	(61.0)
1.85	(47.0)	32	2.35	(59.7)
1.80	(45.5)	36	2.30	(58.5)
1.75	(44.5)	40	2.25	(57.2)
1.70	(43.0)	44	2.20	(55.9)
1.65	(42.0)	48	2.15	(54.7)
1.60	(40.5)	52	2.10	(53.4)
1.55	(39.5)	56	2.05	(52.1)
1.50	(38.0)	60	2.00	(50.9)
1.45	(37.0)	64	1.95	(49.6)
1.40	(35.5)	67	1.90	(48.3)
1.35	(34.5)	70	1.85	(47.0)
1.30	(33.0)	73	1.80	(45.8)
1.25	(32.0)	76	1.75	(44.5)
1.20	(30.5)	79	1.70	(43.2)
1.15	(29.0)	82	1.65	(42.0)
1.10	(28.0)	85	1.60	(40.7)
1.05	(26.5)	88	1.55	(39.4)
1.00	(25.5)	91	1.50	(38.2)
0.95	(24.0)	94	1.45	(36.9)
0.90	(23.0)	97	1.40	(35.6)
0.85	(21.5)	100	1.35	(34.3)
0.80	(20.5)	103	1.30	(33.1)
0.75	(19.0)	106	1.25	(31.8)
0.70	(18.0)	109	1.20	(30.5)
0.65	(16.5)	112	1.15	(29.3)
0.60	(15.0)	115	1.10	(28.0)
0.55	(14.0)	118	1.05	(26.7)
0.50	(12.5)	121	1.00	(25.5)

# D4, 941 - 6.75 in. (171.5 mm)

## Track Shoes <sup>(1)</sup> Moderate Service

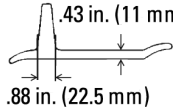
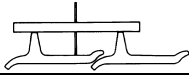

### Depth Gauge

### Ultrasonic

Inches	(mm)	% Worn	Inches	(mm)
1.85	(47.0)	0	2.30	(58.4)
1.80	(45.5)	5	2.25	(57.2)
1.75	(44.5)	10	2.20	(55.9)
1.70	(43.0)	15	2.15	(54.6)
1.65	(42.0)	20	2.10	(53.3)
1.60	(40.5)	25	2.05	(52.1)
1.55	(39.5)	30	2.00	(50.8)
1.50	(38.0)	35	1.95	(49.5)
1.45	(37.0)	40	1.90	(48.3)
1.40	(35.5)	45	1.85	(47.0)
1.35	(34.5)	50	1.80	(45.7)
1.30	(33.0)	55	1.75	(44.5)
1.25	(32.0)	60	1.70	(43.2)
1.20	(30.5)	64	1.65	(41.9)
1.15	(29.0)	68	1.60	(40.6)
1.10	(28.0)	72	1.55	(39.4)
1.05	(26.5)	76	1.50	(38.1)
1.00	(25.5)	80	1.45	(36.8)
0.95	(24.0)	84	1.40	(35.6)
0.90	(23.0)	88	1.35	(34.3)
0.85	(21.5)	92	1.30	(33.0)
0.80	(20.5)	96	1.25	(31.8)
0.75	(19.0)	100	1.20	(30.5)
0.70	(18.0)	104	1.15	(29.2)
0.65	(16.5)	108	1.10	(27.9)
0.60	(15.0)	112	1.05	(26.7)
0.55	(14.0)	116	1.00	(25.4)
0.50	(12.5)	120	0.95	(24.1)



**Track Shoes <sup>(1)</sup>  
Double Grouser**

.43 in. (11 mm)

1.02 in. (26 mm)

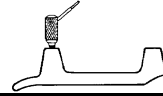
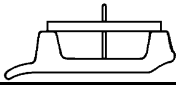

**Depth Gauge**

**Ultrasonic**

Inches	(mm)	% Worn	Inches	(mm)
1.45	(37.0)	0	1.90	(48.3)
1.40	(35.5)	6	1.85	(47.0)
1.35	(34.5)	12	1.80	(45.7)
1.30	(33.0)	18	1.75	(44.5)
1.25	(32.0)	24	1.70	(43.2)
1.20	(30.5)	30	1.65	(41.9)
1.15	(29.0)	35	1.60	(40.6)
1.10	(28.0)	40	1.55	(39.4)
1.05	(26.5)	45	1.50	(38.1)
1.00	(25.5)	50	1.45	(36.8)
0.95	(24.0)	55	1.40	(35.6)
0.90	(23.0)	60	1.35	(34.3)
0.85	(21.5)	65	1.30	(33.0)
0.80	(20.5)	70	1.25	(31.8)
0.75	(19.0)	75	1.20	(30.5)
0.70	(18.0)	80	1.15	(29.2)
0.65	(16.5)	85	1.10	(27.9)
0.60	(15.0)	90	1.05	(26.7)
0.55	(14.0)	95	1.00	(25.4)
0.50	(12.5)	100	0.95	(24.1)
0.45	(11.5)	105	0.90	(22.9)
0.40	(10.0)	110	0.85	(21.6)
0.35	(9.0)	115	0.80	(20.3)
0.30	(7.5)	120	0.75	(19.1)

# D4, 941 - 6.75 in. (171.5 mm)

## Track Shoes <sup>(1)</sup> Triple Grouser

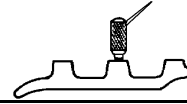
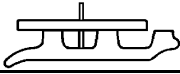
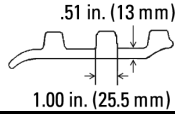

### Depth Gauge

### Ultrasonic

Inches	(mm)	% Worn	Inches	(mm)
0.95	(24.0)	0	1.50	(38.1)
0.90	(23.0)	8	1.45	(36.8)
0.85	(21.5)	16	1.40	(35.6)
0.80	(20.5)	23	1.35	(34.3)
0.75	(19.0)	30	1.30	(33.0)
0.70	(18.0)	37	1.25	(31.8)
0.65	(16.5)	44	1.20	(30.5)
0.60	(15.0)	51	1.15	(29.2)
0.55	(14.0)	58	1.10	(27.9)
0.50	(12.5)	65	1.05	(26.7)
0.45	(11.5)	72	1.00	(25.4)
0.40	(10.0)	79	0.95	(24.1)
0.35	(9.0)	86	0.90	(22.9)
0.30	(7.5)	93	0.85	(21.6)
0.25	(6.5)	100	0.80	(20.3)
0.20	(5.0)	107	0.75	(19.1)
0.15	(4.0)	114	0.70	(17.8)
0.10	(2.5)	121	0.65	(16.5)

**Track Shoes <sup>(1)</sup>  
Self Cleaning**



**Depth Gauge**

Inches	(mm)	% Worn
3.18	(81.0)	0
3.16	(80.5)	6
3.14	(80.0)	12
3.12	(79.0)	18
3.10	(78.5)	24
3.08	(78.0)	30
3.06	(77.5)	36
3.04	(77.0)	42
3.02	(76.5)	48
3.00	(76.0)	54
2.98	(75.5)	60
2.96	(75.0)	66
2.94	(74.5)	72
2.92	(74.0)	76
2.90	(73.5)	80
2.88	(73.0)	84
2.86	(72.5)	88
2.84	(72.0)	92
2.82	(71.5)	96
2.80	(71.0)	100
2.78	(70.5)	104
2.76	(70.0)	108
2.74	(69.5)	112
2.72	(69.0)	116
2.70	(68.5)	120

# D4, 941 - 6.75 in. (171.5 mm)

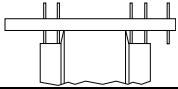

## Idlers <sup>(1)</sup> <sup>(2)</sup> <sup>(3)</sup>



Depth Gauge		
Inches	(mm)	% Worn
0.66	(17.0)	0
0.68	(17.5)	12
0.70	(18.0)	24
0.72	(18.5)	36
0.74	(19.0)	48
0.76	(19.5)	60
0.78	(20.0)	72
0.80	(20.5)	82
0.82	(21.0)	85
0.84	(21.5)	88
0.86	(22.0)	91
0.88	(22.5)	94
0.90	(23.0)	97
0.92	(23.5)	100
0.94	(24.0)	103
0.96	(24.5)	106
0.98	(25.0)	109
1.00	(25.5)	112
1.02	(26.0)	115
1.04	(26.5)	118
1.06	(27.0)	121

Ultrasonic		Center Flange Wear	
Inches	(mm)	Inches	(mm)
0.28	(7.1)	0.00	(0.0)
0.26	(6.6)	0.02	(0.5)
0.24	(6.1)	0.04	(1.0)
0.22	(5.6)	0.06	(1.5)
0.20	(5.1)	0.08	(2.0)
0.18	(4.6)	0.10	(2.5)
0.16	(4.1)	0.12	(3.0)
0.14	(3.6)	0.14	(3.5)
0.12	(3.0)	0.16	(4.0)
0.10	(2.5)	0.18	(4.5)
0.08	(2.0)	0.20	(5.0)
0.06	(1.5)	0.22	(5.5)
0.04	(1.0)	0.24	(6.0)
0.02	(0.5)	0.26	(6.5)
0.00	(0.0)	0.28	(7.0)

### NOTE

Ultrasonic measurement is to determine flange wear only.

- 1 Flange width is 2.69 in. (68.3 mm)
- 2 New tread diameter is 21.9 in. (556 mm), 24.25 in. (616 mm), or 24.36 in. (618.7 mm)
- 3 Wear Chart: 4342

Carrier Rollers <sup>(1)</sup>

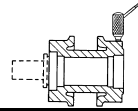
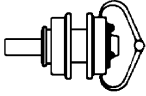

Caliper			Ultrasonic	
Inches	(mm)	% Worn	Inches	(mm)
6.26	(159.0)	0	1.63	(40.4)
6.20	(157.5)	7	1.60	(40.6)
6.14	(156.0)	14	1.57	(39.9)
6.08	(154.5)	21	1.54	(39.1)
6.02	(153.0)	28	1.51	(38.4)
5.96	(151.5)	35	1.48	(37.6)
5.90	(150.0)	42	1.45	(36.8)
5.84	(148.5)	49	1.42	(36.1)
5.78	(147.0)	56	1.39	(35.3)
5.72	(145.5)	63	1.36	(34.5)
5.66	(144.0)	70	1.33	(33.8)
5.60	(142.0)	77	1.30	(33.0)
5.54	(140.5)	84	1.27	(32.3)
5.48	(139.0)	88	1.24	(31.5)
5.42	(137.5)	92	1.21	(30.7)
5.36	(136.0)	96	1.18	(30.0)
5.30	(134.5)	100	1.15	(29.2)
5.24	(133.0)	104	1.12	(28.4)
5.18	(131.5)	108	1.09	(27.7)
5.12	(130.0)	112	1.06	(26.9)
5.06	(128.5)	116	1.03	(26.2)
5.00	(127.0)	120	1.00	(25.4)

1 Wear Chart: 4647

# D4, 941 - 6.75 in. (171.5 mm)

## Track Rollers <sup>(1)</sup> <sup>(2)</sup>

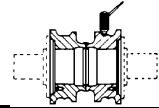
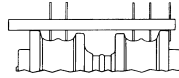
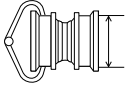

Caliper			Depth Gauge		Ultrasonic	
Inches	(mm)	% Worn	Inches	(mm)	Inches	(mm)
8.00	(203.0)	0	0.54	(13.5)	2.00	(50.8)
7.98	(202.5)	4	0.55	(14.0)	1.99	(50.5)
7.96	(202.0)	8	0.56	(14.0)	1.98	(50.3)
7.94	(201.5)	12	0.57	(14.5)	1.97	(50.0)
7.92	(201.0)	16	0.58	(14.5)	1.96	(49.8)
7.90	(200.5)	20	0.59	(15.0)	1.95	(49.5)
7.88	(200.0)	24	0.60	(15.0)	1.94	(49.3)
7.86	(199.5)	28	0.61	(15.5)	1.93	(49.0)
7.84	(199.0)	31	0.62	(15.5)	1.92	(48.8)
7.82	(198.5)	34	0.63	(16.0)	1.91	(48.5)
7.80	(198.0)	37	0.64	(16.5)	1.90	(48.3)
7.78	(197.5)	40	0.65	(16.5)	1.89	(48.0)
7.76	(197.0)	43	0.66	(17.0)	1.88	(47.8)
7.74	(196.5)	46	0.67	(17.0)	1.87	(47.5)
7.72	(196.0)	49	0.68	(17.5)	1.86	(47.2)
7.70	(195.5)	52	0.69	(17.5)	1.85	(47.0)
7.68	(195.0)	55	0.70	(18.0)	1.84	(46.7)
7.66	(194.5)	58	0.71	(18.0)	1.83	(46.5)
7.64	(194.0)	61	0.72	(18.5)	1.82	(46.2)
7.62	(193.5)	64	0.73	(18.5)	1.81	(46.0)
7.60	(193.0)	67	0.74	(19.0)	1.80	(45.7)
7.58	(192.5)	70	0.75	(19.0)	1.79	(45.5)
7.56	(192.0)	73	0.76	(19.5)	1.78	(45.2)
7.54	(191.5)	76	0.77	(19.5)	1.77	(45.0)
7.52	(191.0)	79	0.78	(20.0)	1.76	(44.7)
7.50	(190.5)	82	0.79	(20.0)	1.75	(44.5)
7.48	(190.0)	85	0.80	(20.5)	1.74	(44.2)
7.46	(189.5)	88	0.81	(20.5)	1.73	(43.9)
7.44	(189.0)	91	0.82	(21.0)	1.72	(43.7)
7.42	(188.5)	94	0.83	(21.0)	1.71	(43.4)
7.40	(188.0)	97	0.84	(21.5)	1.70	(43.2)
7.38	(187.5)	100	0.85	(21.5)	1.69	(42.9)
7.36	(187.0)	103	0.86	(22.0)	1.68	(42.7)
7.34	(186.5)	106	0.87	(22.0)	1.67	(42.4)
7.32	(186.0)	109	0.88	(22.5)	1.66	(42.2)
7.30	(185.5)	112	0.89	(22.5)	1.65	(41.9)
7.28	(185.0)	115	0.90	(23.0)	1.64	(41.7)
7.26	(184.5)	118	0.91	(23.0)	1.63	(41.4)
7.24	(184.0)	121	0.92	(23.5)	1.62	(41.1)

1 Flange diameter is 9.09 in. (231 mm)

2 Wear Chart: 5243



# D5K - 7.50 in. (190 mm)

## Track Links <sup>(1)</sup> SystemOne Track 235-2529

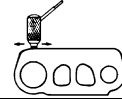
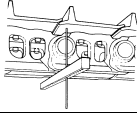

Depth Gauge			Ultrasonic	
Inches	(mm)	% Worn	Inches	(mm)
4.25	(108.0)	0	1.14	(29.0)
4.23	(107.5)	6	1.12	(28.4)
4.21	(107.0)	12	1.10	(27.9)
4.19	(106.5)	18	1.08	(27.4)
4.17	(106.0)	24	1.06	(26.9)
4.15	(105.5)	30	1.04	(26.4)
4.13	(105.0)	35	1.02	(25.9)
4.11	(104.5)	40	1.00	(25.4)
4.09	(104.0)	45	0.98	(24.9)
4.07	(103.5)	50	0.96	(24.4)
4.05	(103.0)	55	0.94	(23.9)
4.03	(102.5)	60	0.92	(23.4)
4.01	(102.0)	65	0.90	(22.9)
3.99	(101.5)	70	0.88	(22.4)
3.97	(101.0)	75	0.86	(21.8)
3.95	(100.5)	80	0.84	(21.3)
3.93	(100.0)	85	0.82	(20.8)
3.91	(99.5)	90	0.80	(20.3)
3.89	(99.0)	95	0.78	(19.8)
3.87	(98.5)	100	0.76	(19.3)
3.85	(98.0)	105	0.74	(18.8)
3.83	(97.5)	110	0.72	(18.3)
3.81	(97.0)	115	0.70	(17.8)
3.79	(96.5)	120	0.68	(17.3)



Track Links <sup>(1)</sup>  
6Y-9261 & 62

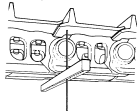

Depth Gauge			Ultrasonic	
Inches	(mm)	% Worn	Inches	(mm)
3.85	(98.0)	0	1.06	(26.9)
3.83	(97.5)	8	1.04	(26.4)
3.81	(97.0)	16	1.02	(25.9)
3.79	(96.5)	23	1.00	(25.4)
3.77	(96.0)	30	0.98	(24.9)
3.75	(95.5)	37	0.96	(24.4)
3.73	(94.5)	44	0.94	(23.9)
3.71	(94.0)	51	0.92	(23.4)
3.69	(93.5)	58	0.90	(22.9)
3.67	(93.0)	65	0.88	(22.4)
3.65	(92.5)	72	0.86	(21.8)
3.63	(92.0)	79	0.84	(21.3)
3.61	(91.5)	86	0.82	(20.8)
3.59	(91.0)	93	0.80	(20.3)
3.57	(90.5)	100	0.78	(19.8)
3.55	(90.0)	107	0.76	(19.3)
3.53	(89.5)	114	0.74	(18.8)
3.51	(89.0)	121	0.72	(18.3)

# D5K - 7.50 in. (190 mm)

## Bushings<sup>(1)</sup> SystemOne Track

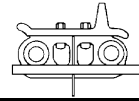

Caliper			Ultrasonic		Depth Gauge	
Inches	(mm)	% Worn	Inches	(mm)	Inches	(mm)
2.39	(60.7)	0	0.43	(10.9)	3.04	(77.2)
2.37	(60.2)	6	0.42	(10.7)	3.03	(77.0)
2.35	(59.7)	12	0.41	(10.4)	3.02	(76.7)
2.33	(59.2)	18	0.40	(10.2)	3.01	(76.5)
2.31	(58.7)	24	0.39	(9.9)	3.00	(76.2)
2.29	(58.2)	30	0.38	(9.7)	2.99	(75.9)
2.27	(57.7)	36	0.37	(9.4)	2.98	(75.7)
2.25	(57.2)	42	0.36	(9.1)	2.97	(75.4)
2.23	(56.6)	48	0.35	(8.9)	2.96	(75.2)
2.21	(56.1)	54	0.34	(8.6)	2.95	(74.9)
2.19	(55.6)	60	0.33	(8.4)	2.94	(74.7)
2.17	(55.1)	66	0.32	(8.1)	2.93	(74.4)
2.15	(54.6)	70	0.31	(7.9)	2.92	(74.2)
2.13	(54.1)	73	0.30	(7.6)	2.91	(73.9)
2.11	(53.6)	76	0.29	(7.4)	2.90	(73.7)
2.09	(53.1)	79	0.28	(7.1)	2.89	(73.4)
2.07	(52.6)	82	0.27	(6.9)	2.88	(73.2)
2.05	(52.1)	85	0.26	(6.6)	2.87	(72.9)
2.03	(51.6)	88	0.25	(6.4)	2.86	(72.6)
2.01	(51.1)	91	0.24	(6.1)	2.85	(72.4)
1.99	(50.5)	94	0.23	(5.8)	2.84	(72.1)
1.97	(50.0)	97	0.22	(5.6)	2.83	(71.9)
1.95	(49.5)	100	0.21	(5.3)	2.82	(71.6)
1.93	(49.0)	103	0.20	(5.1)	2.81	(71.4)
1.91	(48.5)	106	0.19	(4.8)	2.80	(71.1)
1.89	(48.0)	109	0.18	(4.6)	2.79	(70.9)
1.87	(47.5)	112	0.17	(4.3)	2.78	(70.6)
1.85	(47.0)	115	0.16	(4.1)	2.77	(70.4)
1.83	(46.5)	118	0.15	(3.8)	2.76	(70.1)
1.81	(46.0)	121	0.14	(3.6)	2.75	(69.9)

1 Wear Chart: 687/688

**Bushings <sup>(1)</sup>  
External Wear  
Sealed & Lubricated Track**

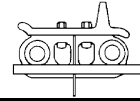
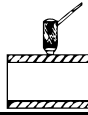

Caliper		Allowable Wear		Ultrasonic		Depth Gauge	
Inches	(mm)	Lesser % Worn	Greater % Worn	Inches	(mm)	Inches	(mm)
2.39	(60.7)	0	0	0.51	(13.0)	2.88	(73.2)
2.37	(60.2)	10	8	0.49	(12.4)	2.86	(72.6)
2.35	(59.7)	20	16	0.47	(11.9)	2.84	(72.1)
2.33	(59.2)	30	24	0.45	(11.4)	2.82	(71.6)
2.31	(58.7)	40	32	0.43	(10.9)	2.80	(71.1)
2.29	(58.2)	50	40	0.41	(10.4)	2.78	(70.6)
2.27	(57.7)	60	44	0.39	(9.9)	2.76	(70.1)
2.25	(57.2)	68	48	0.37	(9.4)	2.74	(69.6)
2.23	(56.6)	72	52	0.35	(8.9)	2.72	(69.1)
2.21	(56.1)	76	56	0.33	(8.4)	2.70	(68.6)
2.19	(55.6)	80	60	0.31	(7.9)	2.68	(68.1)
2.17	(55.1)	84	64	0.29	(7.4)	2.66	(67.6)
2.15	(54.6)	88	68	0.27	(6.9)	2.64	(67.1)
2.13	(54.1)	92	72	0.25	(6.3)	2.62	(66.5)
2.11	(53.6)	96	76	0.23	(5.8)	2.60	(66.0)
2.09	(53.1)	100	80	0.21	(5.3)	2.58	(65.5)
2.07	(52.6)	104	84	0.19	(4.8)	2.56	(65.0)
2.05	(52.1)	108	88	0.17	(4.3)	2.54	(64.5)
2.03	(51.6)	112	92	0.15	(3.8)	2.52	(64.0)
2.01	(51.1)	116	96	0.13	(3.3)	2.50	(63.5)
1.99	(50.5)	120	100	0.11	(2.8)	2.48	(63.0)
1.97	(50.0)		104	0.09	(2.3)	2.46	(62.5)
1.95	(49.5)		108	0.07	(1.8)	2.44	(62.0)
1.93	(49.0)		112	0.05	(1.3)	2.42	(61.5)
1.91	(48.5)		116	0.03	(0.8)	2.40	(61.0)
1.89	(48.0)		120	0.01	(0.3)	2.38	(60.5)

# D5K - 6.75 in. (171.5 mm) and 7.50 in. (190 mm)

## Track Shoes <sup>(1)</sup> Extreme Service

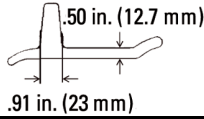
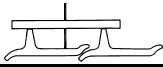

Depth Gauge			Ultrasonic		
Inches	(mm)	% Worn	Inches	(mm)	
2.25	(57.0)	0	2.75	(69.9)	
2.20	(56.0)	4	2.70	(68.6)	
2.15	(54.5)	8	2.65	(67.4)	
2.10	(53.5)	12	2.60	(66.1)	
2.05	(52.0)	16	2.55	(64.8)	
2.00	(51.0)	20	2.50	(63.6)	
1.95	(49.5)	24	2.45	(62.3)	
1.90	(48.5)	28	2.40	(61.0)	
1.85	(47.0)	32	2.35	(59.7)	
1.80	(45.5)	36	2.30	(58.5)	
1.75	(44.5)	40	2.25	(57.2)	
1.70	(43.0)	44	2.20	(55.9)	
1.65	(42.0)	48	2.15	(54.7)	
1.60	(40.5)	52	2.10	(53.4)	
1.55	(39.5)	56	2.05	(52.1)	
1.50	(38.0)	60	2.00	(50.9)	
1.45	(37.0)	64	1.95	(49.6)	
1.40	(35.5)	67	1.90	(48.3)	
1.35	(34.5)	70	1.85	(47.0)	
1.30	(33.0)	73	1.80	(45.8)	
1.25	(32.0)	76	1.75	(44.5)	
1.20	(30.5)	79	1.70	(43.2)	
1.15	(29.0)	82	1.65	(42.0)	
1.10	(28.0)	85	1.60	(40.7)	
1.05	(26.5)	88	1.55	(39.4)	
1.00	(25.5)	91	1.50	(38.2)	
0.95	(24.0)	94	1.45	(36.9)	
0.90	(23.0)	97	1.40	(35.6)	
0.85	(21.5)	100	1.35	(34.3)	
0.80	(20.5)	103	1.30	(33.1)	
0.75	(19.0)	106	1.25	(31.8)	
0.70	(18.0)	109	1.20	(30.5)	
0.65	(16.5)	112	1.15	(29.3)	
0.60	(15.0)	115	1.10	(28.0)	
0.55	(14.0)	118	1.05	(26.7)	
0.50	(12.5)	121	1.00	(25.5)	

## D5K - 6.75 in. (171.5 mm) and 7.50 in. (190 mm)

### Track Shoes <sup>(1)</sup> Moderate Service

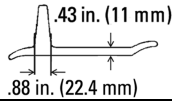
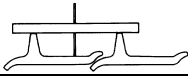

**Depth Gauge**

**Ultrasonic**

Depth Gauge		% Worn	Ultrasonic	
Inches	(mm)		Inches	(mm)
1.85	(47.0)	0	2.30	(58.4)
1.80	(45.5)	5	2.25	(57.2)
1.75	(44.5)	10	2.20	(55.9)
1.70	(43.0)	15	2.15	(54.6)
1.65	(42.0)	20	2.10	(53.3)
1.60	(40.5)	25	2.05	(52.1)
1.55	(39.5)	30	2.00	(50.8)
1.50	(38.0)	35	1.95	(49.5)
1.45	(37.0)	40	1.90	(48.3)
1.40	(35.5)	45	1.85	(47.0)
1.35	(34.5)	50	1.80	(45.7)
1.30	(33.0)	55	1.75	(44.5)
1.25	(32.0)	60	1.70	(43.2)
1.20	(30.5)	64	1.65	(41.9)
1.15	(29.0)	68	1.60	(40.6)
1.10	(28.0)	72	1.55	(39.4)
1.05	(26.5)	76	1.50	(38.1)
1.00	(25.5)	80	1.45	(36.8)
0.95	(24.0)	84	1.40	(35.6)
0.90	(23.0)	88	1.35	(34.3)
0.85	(21.5)	92	1.30	(33.0)
0.80	(20.5)	96	1.25	(31.8)
0.75	(19.0)	100	1.20	(30.5)
0.70	(18.0)	104	1.15	(29.2)
0.65	(16.5)	108	1.10	(27.9)
0.60	(15.0)	112	1.05	(26.7)
0.55	(14.0)	116	1.00	(25.4)
0.50	(12.5)	120	0.95	(24.1)

# D5K - 6.75 in. (171.5 mm)

## Track Shoes <sup>(1)</sup> Double Grouser

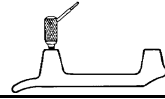
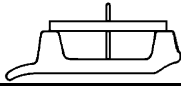
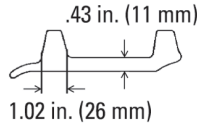

Depth Gauge			Ultrasonic	
Inches	(mm)	% Worn	Inches	(mm)
1.45	(37.0)	0	1.90	(48.3)
1.40	(35.5)	6	1.85	(47.0)
1.35	(34.5)	12	1.80	(45.7)
1.30	(33.0)	18	1.75	(44.5)
1.25	(32.0)	24	1.70	(43.2)
1.20	(30.5)	30	1.65	(41.9)
1.15	(29.0)	35	1.60	(40.6)
1.10	(28.0)	40	1.55	(39.4)
1.05	(26.5)	45	1.50	(38.1)
1.00	(25.5)	50	1.45	(36.8)
0.95	(24.0)	55	1.40	(35.6)
0.90	(23.0)	60	1.35	(34.3)
0.85	(21.5)	65	1.30	(33.0)
0.80	(20.5)	70	1.25	(31.8)
0.75	(19.0)	75	1.20	(30.5)
0.70	(18.0)	80	1.15	(29.2)
0.65	(16.5)	85	1.10	(27.9)
0.60	(15.0)	90	1.05	(26.7)
0.55	(14.0)	95	1.00	(25.4)
0.50	(12.5)	100	0.95	(24.1)
0.45	(11.5)	105	0.90	(22.9)
0.40	(10.0)	110	0.85	(21.6)
0.35	(9.0)	115	0.80	(20.3)
0.30	(7.5)	120	0.75	(19.1)

**Idlers <sup>(1)</sup> <sup>(2)</sup> <sup>(3)</sup>**

**Relieved Tread Idler**

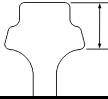

**Center Tread Idler**



**Depth Gauge, Ultrasonic (CTI only) or Caliper**

<b>Inches</b>	<b>(mm)</b>	<b>% Worn</b>	<b>Inches</b>	<b>(mm)</b>
1.76	(44.5)	0	1.00	(25.5)
1.72	(43.5)	8	0.96	(24.5)
1.68	(42.5)	16	0.92	(23.5)
1.64	(41.5)	24	0.88	(22.5)
1.60	(40.5)	32	0.84	(21.5)
1.56	(39.5)	40	0.80	(20.5)
1.52	(38.5)	48	0.76	(19.5)
1.48	(37.5)	56	0.72	(18.5)
1.44	(36.5)	64	0.68	(17.5)
1.40	(35.5)	72	0.64	(16.5)
1.36	(34.5)	80	0.60	(15.0)
1.32	(33.5)	84	0.56	(14.0)
1.28	(32.5)	88	0.52	(13.0)
1.24	(31.5)	92	0.48	(12.0)
1.20	(30.5)	96	0.44	(11.0)
1.16	(29.5)	100	0.40	(10.0)
1.12	(28.5)	104	0.36	(9.0)
1.08	(27.5)	108	0.32	(8.0)
1.04	(26.5)	112	0.28	(7.0)
1.00	(25.5)	116	0.24	(6.0)
0.96	(24.5)	120	0.20	(5.0)

- 1 New tread diameter is 24.39 in. (619.5 mm)
- 2 For measuring instructions, reference General Information topic *Idler Wear – Center Tread Idlers* on, page 51.
- 3 Wear Chart: 4082

# D5K - 6.75 in. (171.5 mm)

## Idlers <sup>(1)</sup> <sup>(2)</sup> <sup>(3)</sup> Conventional Idler

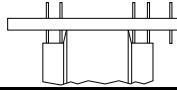

### Depth Gauge

Inches	(mm)	% Worn
0.66	(17.0)	0
0.68	(17.5)	8
0.70	(18.0)	16
0.72	(18.5)	24
0.74	(19.0)	32
0.76	(19.5)	40
0.78	(20.0)	48
0.80	(20.5)	56
0.82	(21.0)	64
0.84	(21.5)	72
0.86	(22.0)	76
0.88	(22.5)	79
0.90	(23.0)	82
0.92	(23.5)	85
0.94	(24.0)	88
0.96	(24.5)	91
0.98	(25.0)	94
1.00	(25.5)	97
1.02	(26.0)	100
1.04	(26.5)	103
1.06	(27.0)	106
1.08	(27.5)	109
1.10	(28.0)	112
1.12	(28.5)	115
1.14	(29.0)	118
1.16	(29.5)	121

- 1 Flange width is 2.68 in. (68 mm)
- 2 New tread diameter is 21.88 in. (556 mm)
- 3 Wear Chart: 4344



Carrier Rollers <sup>(1)</sup>  
SystemOne Track

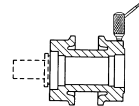
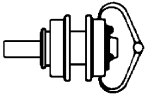

Caliper			Ultrasonic		
Inches	(mm)	% Worn	Inches	(mm)	
6.64	(168.5)	0	1.84	(46.7)	
6.58	(167.0)	5	1.81	(46.0)	
6.52	(165.5)	10	1.78	(45.2)	
6.46	(164.0)	15	1.75	(44.5)	
6.40	(162.5)	20	1.72	(43.7)	
6.34	(161.0)	25	1.69	(42.9)	
6.28	(159.5)	30	1.66	(42.2)	
6.22	(158.0)	35	1.63	(41.4)	
6.16	(156.5)	40	1.60	(40.6)	
6.10	(155.0)	45	1.57	(39.9)	
6.04	(153.5)	50	1.54	(39.1)	
5.98	(152.0)	55	1.51	(38.4)	
5.92	(150.5)	60	1.48	(37.6)	
5.86	(149.0)	65	1.45	(36.8)	
5.80	(147.5)	70	1.42	(36.1)	
5.74	(146.0)	75	1.39	(35.3)	
5.68	(144.5)	79	1.36	(34.5)	
5.62	(142.5)	82	1.33	(33.8)	
5.56	(141.0)	85	1.30	(33.0)	
5.50	(139.5)	88	1.27	(32.3)	
5.44	(138.0)	91	1.24	(31.5)	
5.38	(136.5)	94	1.21	(30.7)	
5.32	(135.0)	97	1.18	(30.0)	
5.26	(133.5)	100	1.15	(29.2)	
5.20	(132.0)	103	1.12	(28.4)	
5.14	(130.5)	106	1.09	(27.7)	
5.08	(129.0)	109	1.06	(26.9)	
5.02	(127.5)	112	1.03	(26.2)	
4.96	(126.0)	115	1.00	(25.4)	
4.90	(124.5)	118	0.97	(24.6)	
4.84	(123.0)	121	0.94	(23.9)	

# D5K - 6.75 in. (171.5 mm)

## Carrier Rollers <sup>(1)</sup> Sealed and Lubricated Track

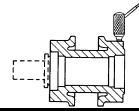
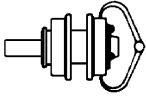

Caliper			Ultrasonic		
Inches	(mm)	% Worn	Inches	(mm)	
6.26	(159.0)	0	1.63	(41.4)	
6.20	(157.5)	7	1.60	(40.6)	
6.14	(156.0)	14	1.57	(39.9)	
6.08	(154.5)	21	1.54	(39.1)	
6.02	(153.0)	28	1.51	(38.4)	
5.96	(151.5)	35	1.48	(37.6)	
5.90	(150.0)	42	1.45	(36.8)	
5.84	(148.5)	49	1.42	(36.1)	
5.78	(147.0)	56	1.39	(35.3)	
5.72	(145.5)	63	1.36	(34.5)	
5.66	(144.0)	70	1.33	(33.8)	
5.60	(142.0)	77	1.30	(33.0)	
5.54	(140.5)	84	1.27	(32.3)	
5.48	(139.0)	88	1.24	(31.5)	
5.42	(137.5)	92	1.21	(30.7)	
5.36	(136.0)	96	1.18	(30.0)	
5.30	(134.5)	100	1.15	(29.2)	
5.24	(133.0)	104	1.12	(28.4)	
5.18	(131.5)	108	1.09	(27.7)	
5.12	(130.0)	112	1.06	(26.9)	
5.06	(128.5)	116	1.03	(26.2)	
5.00	(127.0)	120	1.00	(25.4)	

1 Wear Chart: 4647

Track Rollers <sup>(1) (2)</sup>  
SystemOne Track

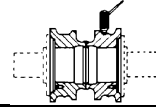
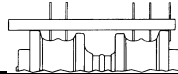

Caliper			Depth Gauge		Ultrasonic	
Inches	(mm)	% Worn	Inches	(mm)	Inches	(mm)
6.91	(175.5)	0	0.67	(17.0)	1.50	(38.1)
6.87	(174.5)	4	0.69	(17.5)	1.48	(37.6)
6.83	(173.5)	8	0.71	(18.0)	1.46	(37.1)
6.79	(172.5)	12	0.73	(18.5)	1.44	(36.6)
6.75	(171.5)	16	0.75	(19.0)	1.42	(36.1)
6.71	(170.5)	20	0.77	(19.5)	1.40	(35.6)
6.67	(169.5)	24	0.79	(20.0)	1.38	(35.1)
6.63	(168.5)	28	0.81	(20.5)	1.36	(34.5)
6.59	(167.5)	32	0.83	(21.0)	1.34	(34.0)
6.55	(166.5)	36	0.85	(21.5)	1.32	(33.5)
6.51	(165.5)	40	0.87	(22.0)	1.30	(33.0)
6.47	(164.5)	43	0.89	(22.5)	1.28	(32.5)
6.43	(163.5)	46	0.91	(23.0)	1.26	(32.0)
6.39	(162.5)	49	0.93	(23.5)	1.24	(31.5)
6.35	(161.5)	52	0.95	(24.0)	1.22	(31.0)
6.31	(160.5)	55	0.97	(24.5)	1.20	(30.5)
6.27	(159.5)	58	0.99	(25.0)	1.18	(30.0)
6.23	(158.0)	61	1.01	(25.5)	1.16	(29.5)
6.19	(157.0)	64	1.03	(26.0)	1.14	(29.0)
6.15	(156.0)	67	1.05	(26.5)	1.12	(28.4)
6.11	(155.0)	70	1.07	(27.0)	1.10	(27.9)
6.07	(154.0)	73	1.09	(27.5)	1.08	(27.4)
6.03	(153.0)	76	1.11	(28.0)	1.06	(26.9)
5.99	(152.0)	79	1.13	(28.5)	1.04	(26.4)
5.95	(151.0)	82	1.15	(29.0)	1.02	(25.9)
5.91	(150.0)	85	1.17	(29.5)	1.00	(25.4)
5.87	(149.0)	88	1.19	(30.0)	0.98	(24.9)
5.83	(148.0)	91	1.21	(30.5)	0.96	(24.4)
5.79	(147.0)	94	1.23	(31.0)	0.94	(23.9)
5.75	(146.0)	97	1.25	(32.0)	0.92	(23.4)
5.71	(145.0)	100	1.27	(32.5)	0.90	(22.9)
5.67	(144.0)	103	1.29	(33.0)	0.88	(22.4)
5.63	(143.0)	106	1.31	(33.5)	0.86	(21.8)
5.59	(142.0)	109	1.33	(34.0)	0.84	(21.3)
5.55	(141.0)	112	1.35	(34.5)	0.82	(20.8)
5.51	(140.0)	115	1.37	(35.0)	0.80	(20.3)
5.47	(139.0)	118	1.39	(35.5)	0.78	(19.8)
5.43	(138.0)	121	1.41	(36.0)	0.76	(19.3)

1 Flange diameter is 8.25 in. (209.5 mm)  
2 Wear Chart: 5289

# D5K - 6.75 in. (171.5 mm)

## Track Rollers <sup>(1) (2)</sup> Sealed & Lubricated Track

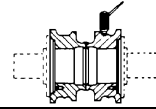

Caliper		% Worn	Depth Gauge		Ultrasonic	
Inches	(mm)		Inches	(mm)	Inches	(mm)
6.89	(175.0)	0	0.47	(12.0)	1.44	(36.6)
6.85	(174.0)	5	0.49	(12.5)	1.42	(36.1)
6.81	(173.0)	10	0.51	(13.0)	1.40	(35.6)
6.77	(172.0)	15	0.53	(13.5)	1.38	(35.1)
6.73	(171.0)	20	0.55	(14.0)	1.36	(34.5)
6.69	(170.0)	25	0.57	(14.5)	1.34	(34.0)
6.65	(169.0)	30	0.59	(15.0)	1.32	(33.5)
6.61	(168.0)	35	0.61	(15.5)	1.30	(33.0)
6.57	(167.0)	40	0.63	(16.0)	1.28	(32.5)
6.53	(166.0)	45	0.65	(16.5)	1.26	(32.0)
6.49	(165.0)	50	0.67	(17.0)	1.24	(31.5)
6.45	(164.0)	55	0.69	(17.5)	1.22	(31.0)
6.41	(163.0)	60	0.71	(18.0)	1.20	(30.5)
6.37	(162.0)	64	0.73	(18.5)	1.18	(30.0)
6.33	(161.0)	67	0.75	(19.0)	1.16	(29.5)
6.29	(160.0)	70	0.77	(19.5)	1.14	(29.0)
6.25	(159.0)	73	0.79	(20.0)	1.12	(28.4)
6.21	(157.5)	76	0.81	(20.5)	1.10	(27.9)
6.17	(156.5)	79	0.83	(21.0)	1.08	(27.4)
6.13	(155.5)	82	0.85	(21.5)	1.06	(26.9)
6.09	(154.5)	85	0.87	(22.0)	1.04	(26.4)
6.05	(153.5)	88	0.89	(22.5)	1.02	(25.9)
6.01	(152.5)	91	0.91	(23.0)	1.00	(25.4)
5.97	(151.5)	94	0.93	(23.5)	0.98	(24.9)
5.93	(150.5)	97	0.95	(24.0)	0.96	(24.4)
5.89	(149.5)	100	0.97	(24.5)	0.94	(23.9)
5.85	(148.5)	103	0.99	(25.0)	0.92	(23.4)
5.81	(147.5)	106	1.01	(25.5)	0.90	(22.9)
5.77	(146.5)	109	1.03	(26.0)	0.88	(22.4)
5.73	(145.5)	112	1.05	(26.5)	0.86	(21.8)
5.69	(144.5)	115	1.07	(27.0)	0.84	(21.3)
5.65	(143.5)	118	1.09	(27.5)	0.82	(20.8)
5.61	(142.5)	121	1.11	(28.0)	0.80	(20.3)

1 Flange diameter is 7.83 in. (198.9 mm)

2 Wear Chart: 5244

**Track Rollers <sup>(1) (2)</sup>  
Sealed & Lubricated Track  
Tall Flange Double Flange Rollers**

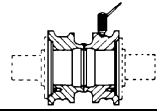
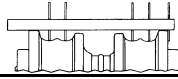

Caliper			Depth Gauge		Ultrasonic	
Inches	(mm)	% Worn	Inches	(mm)	Inches	(mm)
6.89	(175.0)	0	0.67	(17.0)	1.44	(36.6)
6.85	(174.0)	8	0.69	(17.5)	1.42	(36.1)
6.81	(173.0)	16	0.71	(18.0)	1.40	(35.6)
6.77	(172.0)	24	0.73	(18.5)	1.38	(35.1)
6.73	(171.0)	32	0.75	(19.0)	1.36	(34.5)
6.69	(170.0)	40	0.77	(19.5)	1.34	(34.0)
6.65	(169.0)	48	0.79	(20.0)	1.32	(33.5)
6.61	(168.0)	56	0.81	(20.5)	1.30	(33.0)
6.57	(167.0)	64	0.83	(21.0)	1.28	(32.5)
6.53	(166.0)	72	0.85	(21.5)	1.26	(32.0)
6.49	(165.0)	80	0.87	(22.0)	1.24	(31.5)
6.45	(164.0)	88	0.89	(22.5)	1.22	(31.0)
6.41	(163.0)	94	0.91	(23.0)	1.20	(30.5)
6.37	(162.0)	100	0.93	(23.5)	1.18	(30.0)
6.33	(161.0)	106	0.95	(24.0)	1.16	(29.5)
6.29	(160.0)	112	0.97	(24.5)	1.14	(29.0)
6.25	(159.0)	118	0.99	(25.0)	1.12	(28.4)
6.21	(157.5)	124	1.01	(25.5)	1.10	(27.9)

1 Flange diameter is 8.23 in. (209 mm)  
2 Wear Chart: 5254



# D5G, D5C, 939 - 6.75 in. (171.5 mm)

## Track Links <sup>(1)</sup> SystemOne Track 235-2514

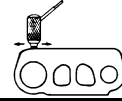
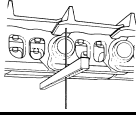

Depth Gauge			Ultrasonic	
Inches	(mm)	% Worn	Inches	(mm)
4.25	(108.0)	0	1.14	(29.0)
4.23	(107.5)	6	1.12	(28.4)
4.21	(107.0)	12	1.10	(27.9)
4.19	(106.5)	18	1.08	(27.4)
4.17	(106.0)	24	1.06	(26.9)
4.15	(105.5)	30	1.04	(26.4)
4.13	(105.0)	35	1.02	(25.9)
4.11	(104.5)	40	1.00	(25.4)
4.09	(104.0)	45	0.98	(24.9)
4.07	(103.5)	50	0.96	(24.4)
4.05	(103.0)	55	0.94	(23.9)
4.03	(102.5)	60	0.92	(23.4)
4.01	(102.0)	65	0.90	(22.9)
3.99	(101.5)	70	0.88	(22.4)
3.97	(101.0)	75	0.86	(21.8)
3.95	(100.5)	80	0.84	(21.3)
3.93	(100.0)	85	0.82	(20.8)
3.91	(99.5)	90	0.80	(20.3)
3.89	(99.0)	95	0.78	(19.8)
3.87	(98.5)	100	0.76	(19.3)
3.85	(98.0)	105	0.74	(18.8)
3.83	(97.5)	110	0.72	(18.3)
3.81	(97.0)	115	0.70	(17.8)
3.79	(96.5)	120	0.68	(17.3)

# D5G, D5C, 939 - 6.75 in. (171.5 mm)

## Track Links <sup>(1)</sup> Rotating Bushing Track 108-0947 & 48

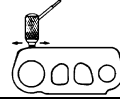
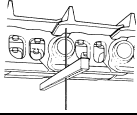

Depth Gauge			Ultrasonic	
Inches	(mm)	% Worn	Inches	(mm)
4.17	(106.0)	0	1.22	(31.0)
4.15	(105.5)	6	1.20	(30.5)
4.13	(105.0)	12	1.18	(30.0)
4.11	(104.5)	18	1.16	(29.5)
4.09	(104.0)	24	1.14	(29.0)
4.07	(103.5)	30	1.12	(28.4)
4.05	(103.0)	36	1.10	(27.9)
4.03	(102.5)	42	1.08	(27.4)
4.01	(102.0)	48	1.06	(26.9)
3.99	(101.5)	54	1.04	(26.4)
3.97	(101.0)	60	1.02	(25.9)
3.95	(100.5)	65	1.00	(25.4)
3.93	(100.0)	70	0.98	(24.9)
3.91	(99.5)	75	0.96	(24.4)
3.89	(99.0)	80	0.94	(23.9)
3.87	(98.5)	85	0.92	(23.4)
3.85	(98.0)	90	0.90	(22.9)
3.83	(97.5)	95	0.88	(22.4)
3.81	(97.0)	100	0.86	(21.8)
3.79	(96.5)	105	0.84	(21.3)
3.77	(96.0)	110	0.82	(20.8)
3.75	(95.5)	115	0.80	(20.3)
3.73	(94.5)	120	0.78	(19.8)



## D5G, D5C, 939 - 6.75 in. (171.5 mm)

### Track Links <sup>(1)</sup> 6Y-9261 & 62

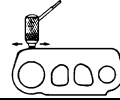
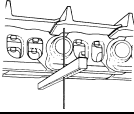

Depth Gauge			Ultrasonic	
Inches	(mm)	% Worn	Inches	(mm)
3.85	(98.0)	0	1.06	(26.9)
3.83	(97.5)	8	1.04	(26.4)
3.81	(97.0)	16	1.02	(25.9)
3.79	(96.5)	23	1.00	(25.4)
3.77	(96.0)	30	0.98	(24.9)
3.75	(95.5)	37	0.96	(24.4)
3.73	(94.5)	44	0.94	(23.9)
3.71	(94.0)	51	0.92	(23.4)
3.69	(93.5)	58	0.90	(22.9)
3.67	(93.0)	65	0.88	(22.4)
3.65	(92.5)	72	0.86	(21.8)
3.63	(92.0)	79	0.84	(21.3)
3.61	(91.5)	86	0.82	(20.8)
3.59	(91.0)	93	0.80	(20.3)
3.57	(90.5)	100	0.78	(19.8)
3.55	(90.0)	107	0.76	(19.3)
3.53	(89.5)	114	0.74	(18.8)
3.51	(89.0)	121	0.72	(18.3)

# D5G, D5C - 6.75 in. (171.5 mm)

## Bushings <sup>(1)</sup> External Wear SystemOne Track

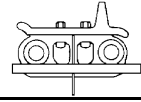
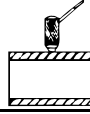
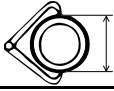

Caliper		Lesser % Worn	Ultrasonic		Depth Gauge	
Inches	(mm)		Inches	(mm)	Inches	(mm)
2.39	(60.7)	0	0.43	(10.9)	3.04	(77.2)
2.37	(60.2)	6	0.42	(10.7)	3.03	(77.0)
2.35	(59.7)	12	0.41	(10.4)	3.02	(76.7)
2.33	(59.2)	18	0.40	(10.2)	3.01	(76.5)
2.31	(58.7)	24	0.39	(9.9)	3.00	(76.2)
2.29	(58.2)	30	0.38	(9.7)	2.99	(75.9)
2.27	(57.7)	36	0.37	(9.4)	2.98	(75.7)
2.25	(57.2)	42	0.36	(9.1)	2.97	(75.4)
2.23	(56.6)	48	0.35	(8.9)	2.96	(75.2)
2.21	(56.1)	54	0.34	(8.6)	2.95	(74.9)
2.19	(55.6)	60	0.33	(8.4)	2.94	(74.7)
2.17	(55.1)	66	0.32	(8.1)	2.93	(74.4)
2.15	(54.6)	70	0.31	(7.9)	2.92	(74.2)
2.13	(54.1)	73	0.30	(7.6)	2.91	(73.9)
2.11	(53.6)	76	0.29	(7.4)	2.90	(73.7)
2.09	(53.1)	79	0.28	(7.1)	2.89	(73.4)
2.07	(52.6)	82	0.27	(6.9)	2.88	(73.2)
2.05	(52.1)	85	0.26	(6.6)	2.87	(72.9)
2.03	(51.6)	88	0.25	(6.4)	2.86	(72.6)
2.01	(51.1)	91	0.24	(6.1)	2.85	(72.4)
1.99	(50.5)	94	0.23	(5.8)	2.84	(72.1)
1.97	(50.0)	97	0.22	(5.6)	2.83	(71.9)
1.95	(49.5)	100	0.21	(5.3)	2.82	(71.6)
1.93	(49.0)	103	0.20	(5.1)	2.81	(71.4)
1.91	(48.5)	106	0.19	(4.8)	2.80	(71.1)
1.89	(48.0)	109	0.18	(4.6)	2.79	(70.9)
1.87	(47.5)	112	0.17	(4.3)	2.78	(70.6)
1.85	(47.0)	115	0.16	(4.1)	2.77	(70.4)
1.83	(46.5)	118	0.15	(3.8)	2.76	(70.1)
1.81	(46.0)	121	0.14	(3.6)	2.75	(69.9)

# D5G, D5C, 939 - 6.75 in. (171.5 mm)

**Bushings <sup>(1)</sup>**  
**External Wear**  
**Rotating Bushing Track**  
**Use with 108-0947 & 48 Links**

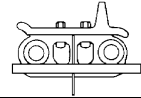
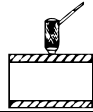

Caliper			Ultrasonic		Depth Gauge	
Inches	(mm)	% Worn	Inches	(mm)	Inches	(mm)
2.39	(60.7)	0	0.47	(11.9)	2.96	(75.2)
2.35	(59.7)	8	0.45	(11.4)	2.94	(74.7)
2.31	(58.7)	16	0.43	(10.9)	2.92	(74.2)
2.27	(57.7)	24	0.41	(10.4)	2.90	(73.7)
2.23	(56.6)	32	0.39	(9.9)	2.88	(73.2)
2.19	(55.6)	40	0.37	(9.4)	2.86	(72.6)
2.15	(54.6)	48	0.35	(8.9)	2.84	(72.1)
2.11	(53.6)	56	0.33	(8.4)	2.82	(71.6)
2.07	(52.6)	60	0.31	(7.9)	2.80	(71.1)
2.03	(51.6)	64	0.29	(7.4)	2.78	(70.6)
1.99	(50.5)	68	0.27	(6.9)	2.76	(70.1)
1.95	(49.5)	72	0.25	(6.3)	2.74	(69.6)
1.91	(48.5)	76	0.23	(5.8)	2.72	(69.1)
1.87	(47.5)	80	0.21	(5.3)	2.70	(68.6)
1.83	(46.5)	84	0.19	(4.8)	2.68	(68.1)
1.79	(45.5)	88	0.17	(4.3)	2.66	(67.6)
1.75	(44.5)	92	0.15	(3.8)	2.64	(67.1)
1.71	(43.4)	96	0.13	(3.3)	2.62	(66.5)
1.67	(42.4)	100	0.11	(2.8)	2.60	(66.0)
1.63	(41.4)	104	0.09	(2.3)	2.58	(65.5)
1.59	(40.4)	108	0.07	(1.8)	2.56	(65.0)
1.55	(39.4)	112	0.05	(1.3)	2.54	(64.5)
1.51	(38.4)	116	0.03	(0.8)	2.52	(64.0)
1.47	(37.3)	120	0.01	(0.3)	2.50	(63.5)

# D5G, D5C, 939 - 6.75 in. (171.5 mm)

**Bushings <sup>(1)</sup>**  
**External Wear**  
**Sealed & Lubricated Track**  
**Use with 6Y-9261 & 62 Links and Large Stepped Bushings**

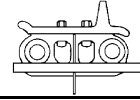
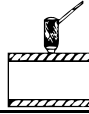
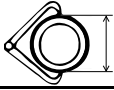

Caliper		Allowable Wear		Ultrasonic		Depth Gauge	
Inches	(mm)	Lesser % Worn	Greater % Worn	Inches	(mm)	Inches	(mm)
2.39	(60.7)	0	0	0.51	(13.0)	2.88	(73.2)
2.37	(60.2)	10	8	0.49	(12.4)	2.86	(72.6)
2.35	(59.7)	20	16	0.47	(11.9)	2.84	(72.1)
2.33	(59.2)	30	24	0.45	(11.4)	2.82	(71.6)
2.31	(58.7)	40	32	0.43	(10.9)	2.80	(71.1)
2.29	(58.2)	50	40	0.41	(10.4)	2.78	(70.6)
2.27	(57.7)	60	44	0.39	(9.9)	2.76	(70.1)
2.25	(57.2)	68	48	0.37	(9.4)	2.74	(69.6)
2.23	(56.6)	72	52	0.35	(8.9)	2.72	(69.1)
2.21	(56.1)	76	56	0.33	(8.4)	2.70	(68.6)
2.19	(55.6)	80	60	0.31	(7.9)	2.68	(68.1)
2.17	(55.1)	84	64	0.29	(7.4)	2.66	(67.6)
2.15	(54.6)	88	68	0.27	(6.9)	2.64	(67.1)
2.13	(54.1)	92	72	0.25	(6.3)	2.62	(66.5)
2.11	(53.6)	96	76	0.23	(5.8)	2.60	(66.0)
2.09	(53.1)	100	80	0.21	(5.3)	2.58	(65.5)
2.07	(52.6)	104	84	0.19	(4.8)	2.56	(65.0)
2.05	(52.1)	108	88	0.17	(4.3)	2.54	(64.5)
2.03	(51.6)	112	92	0.15	(3.8)	2.52	(64.0)
2.01	(51.1)	116	96	0.13	(3.3)	2.50	(63.5)
1.99	(50.5)	120	100	0.11	(2.8)	2.48	(63.0)
1.97	(50.0)		104	0.09	(2.3)	2.46	(62.5)
1.95	(49.5)		108	0.07	(1.8)	2.44	(62.0)
1.93	(49.0)		112	0.05	(1.3)	2.42	(61.5)
1.91	(48.5)		116	0.03	(0.8)	2.40	(61.0)
1.89	(48.0)		120	0.01	(0.3)	2.38	(60.5)

**Bushings <sup>(1)</sup>  
External Wear  
Sealed & Lubricated Track  
Use with 6Y-9261 & 62 Links and Small Stepped Bushings**

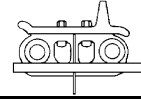
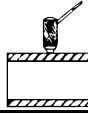
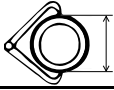

Caliper		Allowable Wear		Ultrasonic		Depth Gauge	
Inches	(mm)	Lesser % Worn	Greater % Worn	Inches	(mm)	Inches	(mm)
2.23	(56.6)	0	0	0.43	(10.9)	2.80	(71.1)
2.21	(56.1)	12	10	0.41	(10.4)	2.78	(70.6)
2.19	(55.6)	24	20	0.39	(9.9)	2.76	(70.1)
2.17	(55.1)	36	30	0.37	(9.4)	2.74	(69.6)
2.15	(54.6)	48	40	0.35	(8.9)	2.72	(69.1)
2.13	(54.1)	60	50	0.33	(8.4)	2.70	(68.6)
2.11	(53.6)	70	60	0.31	(7.9)	2.68	(68.1)
2.09	(53.1)	76	64	0.29	(7.4)	2.66	(67.6)
2.07	(52.6)	82	68	0.27	(6.9)	2.64	(67.1)
2.05	(52.1)	88	72	0.25	(6.4)	2.62	(66.5)
2.03	(51.6)	94	76	0.23	(5.8)	2.60	(66.0)
2.01	(51.1)	100	80	0.21	(5.3)	2.58	(65.5)
1.99	(50.5)	106	84	0.19	(4.8)	2.56	(65.0)
1.97	(50.0)	112	88	0.17	(4.3)	2.54	(64.5)
1.95	(49.5)	118	92	0.15	(3.8)	2.52	(64.0)
1.93	(49.0)	124	96	0.13	(3.3)	2.50	(63.5)
1.91	(48.5)		100	0.11	(2.8)	2.48	(63.0)
1.89	(48.0)		104	0.09	(2.3)	2.46	(62.5)
1.87	(47.5)		108	0.07	(1.8)	2.44	(62.0)
1.85	(47.0)		112	0.05	(1.3)	2.42	(61.5)
1.83	(46.5)		116	0.03	(0.8)	2.40	(61.0)
1.81	(46.0)		120	0.01	(0.3)	2.38	(60.5)

# D5G, D5C, 939 - 6.75 in. (171.5 mm)

## Track Shoes <sup>(1)</sup> Extreme Service

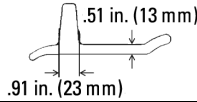
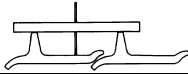

### Depth Gauge

### Ultrasonic

Inches	(mm)	% Worn	Inches	(mm)
2.25	(57.0)	0	2.75	(69.9)
2.20	(56.0)	4	2.70	(68.6)
2.15	(54.5)	8	2.65	(67.4)
2.10	(53.5)	12	2.60	(66.1)
2.05	(52.0)	16	2.55	(64.8)
2.00	(51.0)	20	2.50	(63.6)
1.95	(49.5)	24	2.45	(62.3)
1.90	(48.5)	28	2.40	(61.0)
1.85	(47.0)	32	2.35	(59.7)
1.80	(45.5)	36	2.30	(58.5)
1.75	(44.5)	40	2.25	(57.2)
1.70	(43.0)	44	2.20	(55.9)
1.65	(42.0)	48	2.15	(54.7)
1.60	(40.5)	52	2.10	(53.4)
1.55	(39.5)	56	2.05	(52.1)
1.50	(38.0)	60	2.00	(50.9)
1.45	(37.0)	64	1.95	(49.6)
1.40	(35.5)	67	1.90	(48.3)
1.35	(34.5)	70	1.85	(47.0)
1.30	(33.0)	73	1.80	(45.8)
1.25	(32.0)	76	1.75	(44.5)
1.20	(30.5)	79	1.70	(43.2)
1.15	(29.0)	82	1.65	(42.0)
1.10	(28.0)	85	1.60	(40.7)
1.05	(26.5)	88	1.55	(39.4)
1.00	(25.5)	91	1.50	(38.2)
0.95	(24.0)	94	1.45	(36.9)
0.90	(23.0)	97	1.40	(35.6)
0.85	(21.5)	100	1.35	(34.3)
0.80	(20.5)	103	1.30	(33.1)
0.75	(19.0)	106	1.25	(31.8)
0.70	(18.0)	109	1.20	(30.5)
0.65	(16.5)	112	1.15	(29.3)
0.60	(15.0)	115	1.10	(28.0)
0.55	(14.0)	118	1.05	(26.7)
0.50	(12.5)	121	1.00	(25.5)

# D5G, D5C, 939 - 6.75 in. (171.5 mm)

## Track Shoes <sup>(1)</sup> Moderate Service

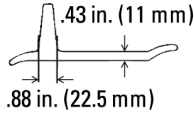
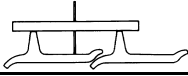

### Depth Gauge

### Ultrasonic

Inches	(mm)	% Worn	Inches	(mm)
1.85	(47.0)	0	2.30	(58.4)
1.80	(45.5)	5	2.25	(57.2)
1.75	(44.5)	10	2.20	(55.9)
1.70	(43.0)	15	2.15	(54.6)
1.65	(42.0)	20	2.10	(53.3)
1.60	(40.5)	25	2.05	(52.1)
1.55	(39.5)	30	2.00	(50.8)
1.50	(38.0)	35	1.95	(49.5)
1.45	(37.0)	40	1.90	(48.3)
1.40	(35.5)	45	1.85	(47.0)
1.35	(34.5)	50	1.80	(45.7)
1.30	(33.0)	55	1.75	(44.5)
1.25	(32.0)	60	1.70	(43.2)
1.20	(30.5)	64	1.65	(41.9)
1.15	(29.0)	68	1.60	(40.6)
1.10	(28.0)	72	1.55	(39.4)
1.05	(26.5)	76	1.50	(38.1)
1.00	(25.5)	80	1.45	(36.8)
0.95	(24.0)	84	1.40	(35.6)
0.90	(23.0)	88	1.35	(34.3)
0.85	(21.5)	92	1.30	(33.0)
0.80	(20.5)	96	1.25	(31.8)
0.75	(19.0)	100	1.20	(30.5)
0.70	(18.0)	104	1.15	(29.2)
0.65	(16.5)	108	1.10	(27.9)
0.60	(15.0)	112	1.05	(26.7)
0.55	(14.0)	116	1.00	(25.4)
0.50	(12.5)	120	0.95	(24.1)

# D5G, D5C, 939 - 6.75 in. (171.5 mm)

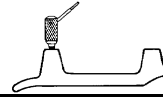
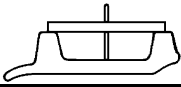
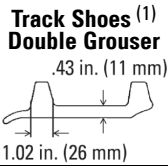

Depth Gauge			Ultrasonic	
Inches	(mm)	% Worn	Inches	(mm)
1.45	(37.0)	0	1.90	(48.3)
1.40	(35.5)	6	1.85	(47.0)
1.35	(34.5)	12	1.80	(45.7)
1.30	(33.0)	18	1.75	(44.5)
1.25	(32.0)	24	1.70	(43.2)
1.20	(30.5)	30	1.65	(41.9)
1.15	(29.0)	35	1.60	(40.6)
1.10	(28.0)	40	1.55	(39.4)
1.05	(26.5)	45	1.50	(38.1)
1.00	(25.5)	50	1.45	(36.8)
0.95	(24.0)	55	1.40	(35.6)
0.90	(23.0)	60	1.35	(34.3)
0.85	(21.5)	65	1.30	(33.0)
0.80	(20.5)	70	1.25	(31.8)
0.75	(19.0)	75	1.20	(30.5)
0.70	(18.0)	80	1.15	(29.2)
0.65	(16.5)	85	1.10	(27.9)
0.60	(15.0)	90	1.05	(26.7)
0.55	(14.0)	95	1.00	(25.4)
0.50	(12.5)	100	0.95	(24.1)
0.45	(11.5)	105	0.90	(22.9)
0.40	(10.0)	110	0.85	(21.6)
0.35	(9.0)	115	0.80	(20.3)
0.30	(7.5)	120	0.75	(19.1)



# D5G, D5C, 939 - 6.75 in. (171.5 mm)

## Track Shoes <sup>(1)</sup> Self Cleaning



Depth Gauge

Inches	(mm)	% Worn
3.18	(81.0)	0
3.16	(80.5)	6
3.14	(80.0)	12
3.12	(79.0)	18
3.10	(78.5)	24
3.08	(78.0)	30
3.06	(77.5)	36
3.04	(77.0)	42
3.02	(76.5)	48
3.00	(76.0)	54
2.98	(75.5)	60
2.96	(75.0)	66
2.94	(74.5)	72
2.92	(74.0)	76
2.90	(73.5)	80
2.88	(73.0)	84
2.86	(72.5)	88
2.84	(72.0)	92
2.82	(71.5)	96
2.80	(71.0)	100
2.78	(70.5)	104
2.76	(70.0)	108
2.74	(69.5)	112
2.72	(69.0)	116
2.70	(68.5)	120

# D5G, D5C - 6.75 in. (171.5 mm)

## Idlers <sup>(1)</sup> <sup>(2)</sup> <sup>(3)</sup> Center Tread Idler

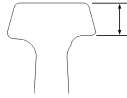

### Ultrasonic, Depth Gauge or Caliper

Inches	(mm)	% Worn
0.98	(25.0)	0
0.96	(24.5)	5
0.94	(24.0)	10
0.92	(23.5)	15
0.90	(23.0)	20
0.88	(22.5)	25
0.86	(22.0)	30
0.84	(21.5)	34
0.82	(21.0)	37
0.80	(20.5)	40
0.78	(20.0)	43
0.76	(19.5)	46
0.74	(19.0)	49
0.72	(18.5)	52
0.70	(18.0)	55
0.68	(17.5)	58
0.66	(17.0)	61
0.64	(16.5)	64
0.62	(15.5)	67
0.60	(15.0)	70
0.58	(14.5)	73
0.56	(14.0)	76
0.54	(13.5)	79
0.52	(13.0)	82
0.50	(12.5)	85
0.48	(12.0)	88
0.46	(11.5)	91
0.44	(11.0)	94
0.42	(10.5)	97
0.40	(10.0)	100
0.38	(9.5)	103
0.36	(9.0)	106
0.34	(8.5)	109
0.32	(8.0)	112
0.30	(7.5)	115
0.28	(7.0)	118
0.26	(6.5)	121

1 New tread diameter is 24.25 in. (616 mm)

2 For measuring instructions, reference General Information topic *Idler Wear — Center Tread Idlers on, page 51.*

3 Wear Chart: 4040

**Idlers** (1) (2) (3)

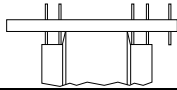

**Depth Gauge**

<b>Inches</b>	<b>(mm)</b>	<b>% Worn</b>
0.66	(17.0)	0
0.68	(17.5)	8
0.70	(18.0)	16
0.72	(18.5)	24
0.74	(19.0)	32
0.76	(19.5)	40
0.78	(20.0)	48
0.80	(20.5)	56
0.82	(21.0)	64
0.84	(21.5)	72
0.86	(22.0)	76
0.88	(22.5)	79
0.90	(23.0)	82
0.92	(23.5)	85
0.94	(24.0)	88
0.96	(24.5)	91
0.98	(25.0)	94
1.00	(25.5)	97
1.02	(26.0)	100
1.04	(26.5)	103
1.06	(27.0)	106
1.08	(27.5)	109
1.10	(28.0)	112
1.12	(28.5)	115
1.14	(29.0)	118
1.16	(29.5)	121

- 1 Flange width is 2.68 in. (68 mm)
- 2 New tread diameter is 21.88 in. (555.8 mm)
- 3 Wear Chart: 4344

# D5G, D5C - 6.75 in. (171.5 mm)

## Carrier Rollers <sup>(1)</sup> SystemOne Track

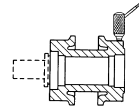
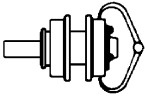

**Caliper  
All**

**Ultrasonic  
One-piece rim**

Inches	(mm)	% Worn	Inches	(mm)
6.64	(168.5)	0	1.28	(32.5)
6.58	(167.0)	5	1.25	(31.8)
6.52	(165.5)	10	1.22	(31.0)
6.46	(164.0)	15	1.19	(30.2)
6.40	(162.5)	20	1.16	(29.5)
6.34	(161.0)	25	1.13	(28.7)
6.28	(159.5)	30	1.10	(27.9)
6.22	(158.0)	35	1.07	(27.2)
6.16	(156.5)	40	1.04	(26.4)
6.10	(155.0)	45	1.01	(25.7)
6.04	(153.5)	50	0.98	(24.9)
5.98	(152.0)	55	0.95	(24.1)
5.92	(150.5)	60	0.92	(23.4)
5.86	(149.0)	65	0.89	(22.6)
5.80	(147.5)	70	0.86	(21.8)
5.74	(146.0)	75	0.83	(21.1)
5.68	(144.5)	79	0.80	(20.3)
5.62	(142.5)	82	0.77	(19.6)
5.56	(141.0)	85	0.74	(18.8)
5.50	(139.5)	88	0.71	(18.0)
5.44	(138.0)	91	0.68	(17.3)
5.38	(136.5)	94	0.65	(16.5)
5.32	(135.0)	97	0.62	(15.7)
5.26	(133.5)	100	0.59	(15.0)
5.20	(132.0)	103	0.56	(14.2)
5.14	(130.5)	106	0.53	(13.5)
5.08	(129.0)	109	0.50	(12.7)
5.02	(127.5)	112	0.47	(11.9)
4.96	(126.0)	115	0.44	(11.2)
4.90	(124.5)	118	0.41	(10.4)
4.84	(123.0)	121	0.38	(9.7)

1 Wear Chart: 4640

## D5G, D5C, 939 - 6.75 in. (171.5 mm)

### Carrier Rollers <sup>(1)</sup> Use with Rotating Bushing Track 108-0947 & 48 Links

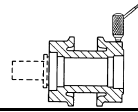
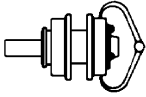

**Caliper**

**Ultrasonic**

Caliper		% Worn	Ultrasonic	
Inches	(mm)		Inches	(mm)
6.26	(159.0)	0	1.63	(41.4)
6.20	(157.5)	5	1.60	(40.6)
6.14	(156.0)	10	1.57	(39.9)
6.08	(154.5)	15	1.54	(39.1)
6.02	(153.0)	20	1.51	(38.4)
5.96	(151.5)	25	1.48	(37.6)
5.90	(150.0)	30	1.45	(36.8)
5.84	(148.5)	35	1.42	(36.1)
5.78	(147.0)	40	1.39	(35.3)
5.72	(145.5)	45	1.36	(34.5)
5.66	(144.0)	50	1.33	(33.8)
5.60	(142.0)	55	1.30	(33.0)
5.54	(140.5)	60	1.27	(32.3)
5.48	(139.0)	65	1.24	(31.5)
5.42	(137.5)	70	1.21	(30.7)
5.36	(136.0)	75	1.18	(30.0)
5.30	(134.5)	79	1.15	(29.2)
5.24	(133.0)	82	1.12	(28.4)
5.18	(131.5)	85	1.09	(27.7)
5.12	(130.0)	88	1.06	(26.9)
5.06	(128.5)	91	1.03	(26.2)
5.00	(127.0)	94	1.00	(25.4)
4.94	(125.5)	97	0.97	(24.6)
4.88	(124.0)	100	0.94	(23.9)
4.82	(122.5)	103	0.91	(23.1)
4.76	(121.0)	106	0.88	(22.4)
4.70	(119.5)	109	0.85	(21.6)
4.64	(118.0)	112	0.82	(20.8)
4.58	(116.5)	115	0.79	(20.1)
4.52	(115.0)	118	0.76	(19.3)
4.46	(113.5)	121	0.73	(18.5)

# D5G, D5C, 939 - 6.75 in. (171.5 mm)

**Carrier Rollers <sup>(1)</sup>**  
**Use with Sealed & Lubricated Track**  
**6Y-9261 & 62 Links**

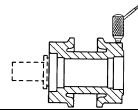
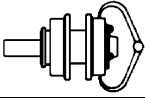

Caliper			Ultrasonic	
Inches	(mm)	% Worn	Inches	(mm)
6.26	(159.0)	0	1.63	(41.4)
6.20	(157.5)	7	1.60	(40.6)
6.14	(156.0)	14	1.57	(39.9)
6.08	(154.5)	21	1.54	(39.1)
6.02	(153.0)	28	1.51	(38.4)
5.96	(151.5)	35	1.48	(37.6)
5.90	(150.0)	42	1.45	(36.8)
5.84	(148.5)	49	1.42	(36.1)
5.78	(147.0)	56	1.39	(35.3)
5.72	(145.5)	63	1.36	(34.5)
5.66	(144.0)	70	1.33	(33.8)
5.60	(142.0)	77	1.30	(33.0)
5.54	(140.5)	84	1.27	(32.3)
5.48	(139.0)	88	1.24	(31.5)
5.42	(137.5)	92	1.21	(30.7)
5.36	(136.0)	96	1.18	(30.0)
5.30	(134.5)	100	1.15	(29.2)
5.24	(133.0)	104	1.12	(28.4)
5.18	(131.5)	108	1.09	(27.7)
5.12	(130.0)	112	1.06	(26.9)
5.06	(128.5)	116	1.03	(26.2)
5.00	(127.0)	120	1.00	(25.4)

**Track Rollers <sup>(1) (2)</sup>  
SystemOne Track**

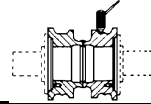
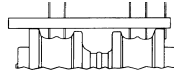
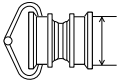

Caliper		% Worn	Depth Gauge		Ultrasonic	
Inches	(mm)		Inches	(mm)	Inches	(mm)
6.91	(175.5)	0	0.67	(17.0)	1.50	(38.1)
6.87	(174.5)	4	0.69	(17.5)	1.48	(37.6)
6.83	(173.5)	8	0.71	(18.0)	1.46	(37.1)
6.79	(172.5)	12	0.73	(18.5)	1.44	(36.6)
6.75	(171.5)	16	0.75	(19.0)	1.42	(36.1)
6.71	(170.5)	20	0.77	(19.5)	1.40	(35.6)
6.67	(169.5)	24	0.79	(20.0)	1.38	(35.1)
6.63	(168.5)	28	0.81	(20.5)	1.36	(34.5)
6.59	(167.5)	32	0.83	(21.0)	1.34	(34.0)
6.55	(166.5)	36	0.85	(21.5)	1.32	(33.5)
6.51	(165.5)	40	0.87	(22.0)	1.30	(33.0)
6.47	(164.5)	43	0.89	(22.5)	1.28	(32.5)
6.43	(163.5)	46	0.91	(23.0)	1.26	(32.0)
6.39	(162.5)	49	0.93	(23.5)	1.24	(31.5)
6.35	(161.5)	52	0.95	(24.0)	1.22	(31.0)
6.31	(160.5)	55	0.97	(24.5)	1.20	(30.5)
6.27	(159.5)	58	0.99	(25.0)	1.18	(30.0)
6.23	(158.0)	61	1.01	(25.5)	1.16	(29.5)
6.19	(157.0)	64	1.03	(26.0)	1.14	(29.0)
6.15	(156.0)	67	1.05	(26.5)	1.12	(28.4)
6.11	(155.0)	70	1.07	(27.0)	1.10	(27.9)
6.07	(154.0)	73	1.09	(27.5)	1.08	(27.4)
6.03	(153.0)	76	1.11	(28.0)	1.06	(26.9)
5.99	(152.0)	79	1.13	(28.5)	1.04	(26.4)
5.95	(151.0)	82	1.15	(29.0)	1.02	(25.9)
5.91	(150.0)	85	1.17	(29.5)	1.00	(25.4)
5.87	(149.0)	88	1.19	(30.0)	0.98	(24.9)
5.83	(148.0)	91	1.21	(30.5)	0.96	(24.4)
5.79	(147.0)	94	1.23	(31.0)	0.94	(23.9)
5.75	(146.0)	97	1.25	(32.0)	0.92	(23.4)
5.71	(145.0)	100	1.27	(32.5)	0.90	(22.9)
5.67	(144.0)	103	1.29	(33.0)	0.88	(22.4)
5.63	(143.0)	106	1.31	(33.5)	0.86	(21.8)
5.59	(142.0)	109	1.33	(34.0)	0.84	(21.3)
5.55	(141.0)	112	1.35	(34.5)	0.82	(20.8)
5.51	(140.0)	115	1.37	(35.0)	0.80	(20.3)
5.47	(139.0)	118	1.39	(35.5)	0.78	(19.8)
5.43	(138.0)	121	1.41	(36.0)	0.76	(19.3)

1 Flange diameter is 8.25 in. (209.5 mm)  
2 Wear Chart: 5246

# D5G, D5C, 939 - 6.75 in. (171.5 mm)

## Track Rollers with End Collars <sup>(1)</sup> <sup>(2)</sup> Use with Rotating Bushing Track 108-0947 & 48 Links

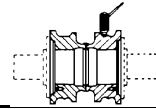
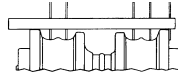
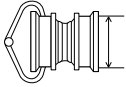

Caliper			Depth Gauge		Ultrasonic	
Inches	(mm)	% Worn	Inches	(mm)	Inches	(mm)
6.89	(175.0)	0	0.47	(12.0)	1.44	(36.6)
6.85	(174.0)	4	0.49	(12.5)	1.42	(36.1)
6.81	(173.0)	8	0.51	(13.0)	1.40	(35.6)
6.77	(172.0)	12	0.53	(13.5)	1.38	(35.1)
6.73	(171.0)	16	0.55	(14.0)	1.36	(34.5)
6.69	(170.0)	20	0.57	(14.5)	1.34	(34.0)
6.65	(169.0)	24	0.59	(15.0)	1.32	(33.5)
6.61	(168.0)	28	0.61	(15.5)	1.30	(33.0)
6.57	(167.0)	32	0.63	(16.0)	1.28	(32.5)
6.53	(166.0)	36	0.65	(16.5)	1.26	(32.0)
6.49	(165.0)	40	0.67	(17.0)	1.24	(31.5)
6.45	(164.0)	43	0.69	(17.5)	1.22	(31.0)
6.41	(163.0)	46	0.71	(18.0)	1.20	(30.5)
6.37	(162.0)	49	0.73	(18.5)	1.18	(30.0)
6.33	(161.0)	52	0.75	(19.0)	1.16	(29.5)
6.29	(160.0)	55	0.77	(19.5)	1.14	(29.0)
6.25	(159.0)	58	0.79	(20.0)	1.12	(28.4)
6.21	(157.5)	61	0.81	(20.5)	1.10	(27.9)
6.17	(156.5)	64	0.83	(21.0)	1.08	(27.4)
6.13	(155.5)	67	0.85	(21.5)	1.06	(26.9)
6.09	(154.5)	70	0.87	(22.0)	1.04	(26.4)
6.05	(153.5)	73	0.89	(22.5)	1.02	(25.9)
6.01	(152.5)	76	0.91	(23.0)	1.00	(25.4)
5.97	(151.5)	79	0.93	(23.5)	0.98	(24.9)
5.93	(150.5)	82	0.95	(24.0)	0.96	(24.4)
5.89	(149.5)	85	0.97	(24.5)	0.94	(23.9)
5.85	(148.5)	88	0.99	(25.0)	0.92	(23.4)
5.81	(147.5)	91	1.01	(25.5)	0.90	(22.9)
5.77	(146.5)	94	1.03	(26.0)	0.88	(22.4)
5.73	(145.5)	97	1.05	(26.5)	0.86	(21.8)
5.69	(144.5)	100	1.07	(27.0)	0.84	(21.3)
5.65	(143.5)	103	1.09	(27.5)	0.82	(20.8)
5.61	(142.5)	106	1.11	(28.0)	0.80	(20.3)
5.57	(141.5)	109	1.13	(28.5)	0.78	(19.8)
5.53	(140.5)	112	1.15	(29.0)	0.76	(19.3)
5.49	(139.5)	115	1.17	(29.5)	0.74	(18.8)
5.45	(138.5)	118	1.19	(30.0)	0.72	(18.3)
5.41	(137.5)	121	1.21	(30.5)	0.70	(17.8)

1 Flange diameter is 7.83 in. (199 mm)

2 Wear Chart: 5251



## D5G, D5C, 939 - 6.75 in. (171.5 mm)

**Track Rollers with End Collars <sup>(1)</sup> <sup>(2)</sup>**  
**Use with Sealed & Lubricated Track**  
**6Y-9261 & 62 Links**

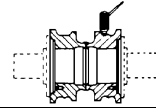
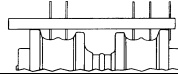

Caliper			Depth Gauge		Ultrasonic	
Inches	(mm)	% Worn	Inches	(mm)	Inches	(mm)
6.89	(175.0)	0	0.47	(12.0)	1.44	(36.6)
6.85	(174.0)	5	0.49	(12.5)	1.42	(36.1)
6.81	(173.0)	10	0.51	(13.0)	1.40	(35.6)
6.77	(172.0)	15	0.53	(13.5)	1.38	(35.1)
6.73	(171.0)	20	0.55	(14.0)	1.36	(34.5)
6.69	(170.0)	25	0.57	(14.5)	1.34	(34.0)
6.65	(169.0)	30	0.59	(15.0)	1.32	(33.5)
6.61	(168.0)	35	0.61	(15.5)	1.30	(33.0)
6.57	(167.0)	40	0.63	(16.0)	1.28	(32.5)
6.53	(166.0)	45	0.65	(16.5)	1.26	(32.0)
6.49	(165.0)	50	0.67	(17.0)	1.24	(31.5)
6.45	(164.0)	55	0.69	(17.5)	1.22	(31.0)
6.41	(163.0)	60	0.71	(18.0)	1.20	(30.5)
6.37	(162.0)	64	0.73	(18.5)	1.18	(30.0)
6.33	(161.0)	67	0.75	(19.0)	1.16	(29.5)
6.29	(160.0)	70	0.77	(19.5)	1.14	(29.0)
6.25	(159.0)	73	0.79	(20.0)	1.12	(28.4)
6.21	(157.5)	76	0.81	(20.5)	1.10	(27.9)
6.17	(156.5)	79	0.83	(21.0)	1.08	(27.4)
6.13	(155.5)	82	0.85	(21.5)	1.06	(26.9)
6.09	(154.5)	85	0.87	(22.0)	1.04	(26.4)
6.05	(153.5)	88	0.89	(22.5)	1.02	(25.9)
6.01	(152.5)	91	0.91	(23.0)	1.00	(25.4)
5.97	(151.5)	94	0.93	(23.5)	0.98	(24.9)
5.93	(150.5)	97	0.95	(24.0)	0.96	(24.4)
5.89	(149.5)	100	0.97	(24.5)	0.94	(23.9)
5.85	(148.5)	103	0.99	(25.0)	0.92	(23.4)
5.81	(147.5)	106	1.01	(25.5)	0.90	(22.9)
5.77	(146.5)	109	1.03	(26.0)	0.88	(22.4)
5.73	(145.5)	112	1.05	(26.5)	0.86	(21.8)
5.69	(144.5)	115	1.07	(27.0)	0.84	(21.3)
5.65	(143.5)	118	1.09	(27.5)	0.82	(20.8)
5.61	(142.5)	121	1.11	(28.0)	0.80	(20.3)

1 Flange diameter is 7.83 in. (199 mm)  
 2 Wear Chart: 5244

# D5G, D5C, 939 - 6.75 in. (171.5 mm)

## Tall Flange, Double Flange Rollers <sup>(1)</sup> <sup>(2)</sup> Use with Rotating Bushing Track 108-0947 & 48 Links

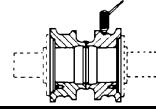

Caliper			Depth Gauge		Ultrasonic	
Inches	(mm)	% Worn	Inches	(mm)	Inches	(mm)
6.89	(175.0)	0	0.67	(17.0)	1.44	(36.6)
6.85	(174.0)	6	0.69	(17.5)	1.42	(36.1)
6.81	(173.0)	12	0.71	(18.0)	1.40	(35.6)
6.77	(172.0)	18	0.73	(18.5)	1.38	(35.1)
6.73	(171.0)	24	0.75	(19.0)	1.36	(34.5)
6.69	(170.0)	30	0.77	(19.5)	1.34	(34.0)
6.65	(169.0)	36	0.79	(20.0)	1.32	(33.5)
6.61	(168.0)	42	0.81	(20.5)	1.30	(33.0)
6.57	(167.0)	48	0.83	(21.0)	1.28	(32.5)
6.53	(166.0)	54	0.85	(21.5)	1.26	(32.0)
6.49	(165.0)	60	0.87	(22.0)	1.24	(31.5)
6.45	(164.0)	64	0.89	(22.5)	1.22	(31.0)
6.41	(163.0)	68	0.91	(23.0)	1.20	(30.5)
6.37	(162.0)	72	0.93	(23.5)	1.18	(30.0)
6.33	(161.0)	76	0.95	(24.0)	1.16	(29.5)
6.29	(160.0)	80	0.97	(24.5)	1.14	(29.0)
6.25	(159.0)	84	0.99	(25.0)	1.12	(28.4)
6.21	(157.5)	88	1.01	(25.5)	1.10	(27.9)
6.17	(156.5)	92	1.03	(26.0)	1.08	(27.4)
6.13	(155.5)	96	1.05	(26.5)	1.06	(26.9)
6.09	(154.5)	100	1.07	(27.0)	1.04	(26.4)
6.05	(153.5)	104	1.09	(27.5)	1.02	(25.9)
6.01	(152.5)	108	1.11	(28.0)	1.00	(25.4)
5.97	(151.5)	112	1.13	(28.5)	0.98	(24.9)
5.93	(150.5)	116	1.15	(29.0)	0.96	(24.4)
5.89	(149.5)	120	1.17	(29.5)	0.94	(23.9)

1 Flange diameter is 8.23 in. (209 mm)

2 Wear Chart: 6140

## D5G, D5C, 939 - 6.75 in. (171.5 mm)

### Track Rollers with Retainers <sup>(1)</sup> (2) Use with Sealed & Lubricated Track 6Y-9261 & 62 Links

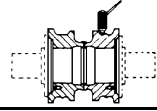
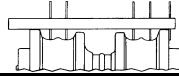
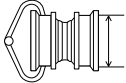

Caliper			Depth Gauge		Ultrasonic	
Inches	(mm)	% Worn	Inches	(mm)	Inches	(mm)
6.89	(175.0)	0	0.47	(12.0)	1.55	(39.4)
6.85	(174.0)	4	0.49	(12.5)	1.53	(38.9)
6.81	(173.0)	8	0.51	(13.0)	1.51	(38.4)
6.77	(172.0)	12	0.53	(13.5)	1.49	(37.8)
6.73	(171.0)	16	0.55	(14.0)	1.47	(37.3)
6.69	(170.0)	20	0.57	(14.5)	1.45	(36.8)
6.65	(169.0)	24	0.59	(15.0)	1.43	(36.3)
6.61	(168.0)	28	0.61	(15.5)	1.41	(35.8)
6.57	(167.0)	32	0.63	(16.0)	1.39	(35.3)
6.53	(166.0)	36	0.65	(16.5)	1.37	(34.8)
6.49	(165.0)	40	0.67	(17.0)	1.35	(34.3)
6.45	(164.0)	44	0.69	(17.5)	1.33	(33.8)
6.41	(163.0)	48	0.71	(18.0)	1.31	(33.3)
6.37	(162.0)	52	0.73	(18.5)	1.29	(32.8)
6.33	(161.0)	56	0.75	(19.0)	1.27	(32.3)
6.29	(160.0)	60	0.77	(19.5)	1.25	(31.8)
6.25	(159.0)	64	0.79	(20.0)	1.23	(31.2)
6.21	(157.5)	68	0.81	(20.5)	1.21	(30.7)
6.17	(156.5)	72	0.83	(21.0)	1.19	(30.2)
6.13	(155.5)	76	0.85	(21.5)	1.17	(29.7)
6.09	(154.5)	80	0.87	(22.0)	1.15	(29.2)
6.05	(153.5)	84	0.89	(22.5)	1.13	(28.7)
6.01	(152.5)	88	0.91	(23.0)	1.11	(28.2)
5.97	(151.5)	92	0.93	(23.5)	1.09	(27.7)
5.93	(150.5)	96	0.95	(24.0)	1.07	(27.2)
5.89	(149.5)	100	0.97	(24.5)	1.05	(26.7)
5.85	(148.5)	103	0.99	(25.0)	1.03	(26.2)
5.81	(147.5)	106	1.01	(25.5)	1.01	(25.7)
5.77	(146.5)	109	1.03	(26.0)	0.99	(25.1)
5.73	(145.5)	112	1.05	(26.5)	0.97	(24.6)
5.69	(144.5)	115	1.07	(27.0)	0.95	(24.1)
5.65	(143.5)	118	1.09	(27.5)	0.93	(23.6)
5.61	(142.5)	121	1.11	(28.0)	0.91	(23.1)

1 Flange diameter is 7.83 in. (199 mm)

2 Wear Chart: 5248

# D5, 955, 951, 561 - 6.91 in. (175.5 mm)

## Track Links <sup>(1)</sup> Genuine and Classic 7T-4539 & 40 257-8012 & 13

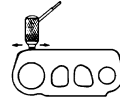
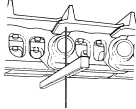

Depth Gauge			Ultrasonic	
Inches	(mm)	% Worn	Inches	(mm)
4.29	(109.0)	0	1.45	(36.8)
4.27	(108.5)	5	1.43	(36.3)
4.25	(108.0)	10	1.41	(35.8)
4.23	(107.5)	15	1.39	(35.3)
4.27	(107.0)	20	1.37	(34.8)
4.19	(106.5)	25	1.35	(34.3)
4.17	(106.0)	30	1.33	(33.8)
4.15	(105.5)	35	1.31	(33.3)
4.13	(105.0)	40	1.29	(32.8)
4.11	(104.5)	45	1.27	(32.3)
4.09	(104.0)	50	1.25	(31.8)
4.07	(103.5)	55	1.23	(31.2)
4.05	(103.0)	60	1.21	(30.7)
4.03	(102.5)	65	1.19	(30.2)
4.01	(102.0)	70	1.17	(29.7)
3.99	(101.5)	75	1.15	(29.2)
3.97	(101.0)	80	1.13	(28.7)
3.95	(100.5)	84	1.11	(28.2)
3.93	(100.0)	88	1.09	(27.7)
3.91	(99.5)	92	1.07	(27.2)
3.89	(99.0)	96	1.05	(26.7)
3.87	(98.5)	100	1.03	(26.2)
3.85	(98.0)	104	1.01	(25.7)
3.83	(97.5)	108	0.99	(25.1)
3.81	(97.0)	112	0.97	(24.6)
3.79	(96.5)	116	0.95	(24.1)
3.77	(96.0)	120	0.93	(23.6)

**Track Links <sup>(1)</sup>  
Genuine and Classic  
3P-7153 & 54  
175-8248 & 49**

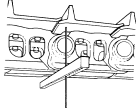

Depth Gauge			Ultrasonic	
Inches	(mm)	% Worn	Inches	(mm)
4.06	(103.0)	0	1.22	(31.0)
4.04	(102.5)	6	1.20	(30.5)
4.02	(102.0)	12	1.18	(30.0)
4.00	(101.5)	18	1.16	(29.5)
3.98	(101.0)	24	1.14	(29.0)
3.96	(100.5)	30	1.12	(28.4)
3.94	(100.0)	36	1.10	(27.9)
3.92	(99.5)	42	1.08	(27.4)
3.90	(99.0)	48	1.06	(26.9)
3.88	(98.5)	54	1.04	(26.4)
3.86	(98.0)	60	1.02	(25.9)
3.84	(97.5)	66	1.00	(25.4)
3.82	(97.0)	72	0.98	(24.9)
3.80	(96.5)	76	0.96	(24.4)
3.78	(96.0)	80	0.94	(23.9)
3.76	(95.5)	84	0.92	(23.4)
3.74	(95.0)	88	0.90	(22.9)
3.72	(94.5)	92	0.88	(22.4)
3.70	(94.0)	96	0.86	(21.8)
3.68	(93.5)	100	0.84	(21.3)
3.66	(93.0)	104	0.82	(20.8)
3.64	(92.5)	108	0.80	(20.3)
3.62	(92.0)	112	0.78	(19.8)
3.60	(91.5)	116	0.76	(19.3)
3.58	(91.0)	120	0.74	(18.8)

# D5, 955, 951, 561 - 6.91 in. (175.5 mm)

## Bushings <sup>(1)</sup> External Wear Sealed & Lubricated Track

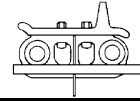
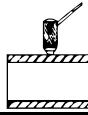

Caliper		Allowable Wear		Ultrasonic		Depth Gauge	
Inches	(mm)	Lesser % Worn	Greater % Worn	Inches	(mm)	Inches	(mm)
2.44	(62.0)	0	0	0.48	(12.2)	2.90	(73.7)
2.42	(61.5)	10	8	0.46	(11.7)	2.88	(73.2)
2.40	(61.0)	20	16	0.44	(11.2)	2.86	(72.6)
2.38	(60.5)	30	24	0.42	(10.7)	2.84	(72.1)
2.36	(59.9)	40	32	0.40	(10.2)	2.82	(71.6)
2.34	(59.4)	50	40	0.38	(9.7)	2.80	(71.1)
2.32	(58.9)	60	48	0.36	(9.1)	2.78	(70.6)
2.30	(58.4)	70	56	0.34	(8.6)	2.76	(70.1)
2.28	(57.9)	76	64	0.32	(8.1)	2.74	(69.6)
2.26	(57.4)	82	68	0.30	(7.6)	2.72	(69.1)
2.24	(56.9)	88	72	0.28	(7.1)	2.70	(68.6)
2.22	(56.4)	94	76	0.26	(6.6)	2.68	(68.1)
2.20	(55.9)	100	80	0.24	(6.1)	2.66	(67.6)
2.18	(55.4)	106	84	0.22	(5.6)	2.64	(67.1)
2.16	(54.9)	112	88	0.20	(5.1)	2.62	(66.5)
2.14	(54.4)	118	92	0.18	(4.6)	2.60	(66.0)
2.12	(53.8)	124	96	0.16	(4.1)	2.58	(65.5)
2.10	(53.3)		100	0.14	(3.6)	2.56	(65.0)
2.08	(52.8)		104	0.12	(3.0)	2.54	(64.5)
2.06	(52.3)		108	0.10	(2.5)	2.52	(64.0)
2.04	(51.8)		112	0.08	(2.0)	2.50	(63.5)
2.02	(51.3)		116	0.06	(1.5)	2.48	(63.0)
2.00	(50.8)		120	0.04	(1.0)	2.46	(62.5)

1 Wear Chart: 661

# D5B, D6, 951, 955 - 6.91 in. (175.5 mm)

## Bushings <sup>(1)</sup> Classic External Wear Sealed & Lubricated Track

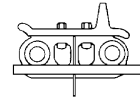
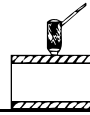
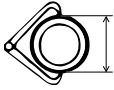

Caliper		Allowable Wear		Ultrasonic		Depth Gauge	
Inches	(mm)	Lesser % Worn	Greater % Worn	Inches	(mm)	Inches	(mm)
2.31	(58.7)	0	0	0.41	(10.4)	2.84	(72.1)
2.30	(58.4)	6	5	0.40	(10.2)	2.83	(71.9)
2.29	(58.2)	12	10	0.39	(9.9)	2.82	(71.6)
2.28	(57.9)	18	15	0.38	(9.7)	2.81	(71.4)
2.27	(57.7)	24	20	0.37	(9.4)	2.80	(71.1)
2.26	(57.4)	30	25	0.36	(9.1)	2.79	(70.9)
2.25	(57.2)	36	30	0.35	(8.9)	2.78	(70.6)
2.24	(56.9)	42	35	0.34	(8.6)	2.77	(70.4)
2.23	(56.6)	48	40	0.33	(8.4)	2.76	(70.1)
2.22	(56.4)	54	45	0.32	(8.1)	2.75	(69.9)
2.21	(56.1)	60	50	0.31	(7.9)	2.74	(69.6)
2.20	(55.9)	66	55	0.30	(7.6)	2.73	(69.3)
2.19	(55.6)	72	60	0.29	(7.4)	2.72	(69.1)
2.18	(55.4)	78	65	0.28	(7.1)	2.71	(68.8)
2.17	(55.1)	84	70	0.27	(6.9)	2.70	(68.6)
2.16	(54.9)	88	72	0.26	(6.6)	2.69	(68.3)
2.15	(54.6)	91	74	0.25	(6.4)	2.68	(68.1)
2.14	(54.4)	94	76	0.24	(6.1)	2.67	(67.8)
2.13	(54.1)	97	78	0.23	(5.8)	2.66	(67.6)
2.12	(53.8)	100	80	0.22	(5.6)	2.65	(67.3)
2.11	(53.6)	103	82	0.21	(5.3)	2.64	(67.1)
2.10	(53.3)	106	84	0.20	(5.1)	2.63	(66.8)
2.09	(53.1)	109	86	0.19	(4.8)	2.62	(66.5)
2.08	(52.8)	112	88	0.18	(4.6)	2.61	(66.3)
2.07	(52.6)	115	90	0.17	(4.3)	2.60	(66.0)
2.06	(52.3)	118	92	0.16	(4.1)	2.59	(65.8)
2.05	(52.1)	121	94	0.15	(3.8)	2.58	(65.5)
2.04	(51.8)		96	0.14	(3.6)	2.57	(65.3)
2.03	(51.6)		98	0.13	(3.3)	2.56	(65.0)
2.02	(51.3)		100	0.12	(3.0)	2.55	(64.8)
2.01	(51.1)		102	0.11	(2.8)	2.54	(64.5)
2.00	(50.8)		104	0.10	(2.5)	2.53	(64.3)
1.99	(50.5)		106	0.09	(2.3)	2.52	(64.0)
1.98	(50.3)		108	0.08	(2.0)	2.51	(63.8)
1.97	(50.0)		110	0.07	(1.8)	2.50	(63.5)
1.96	(49.8)		112	0.06	(1.5)	2.49	(63.2)
1.95	(49.5)		114	0.05	(1.3)	2.48	(63.0)
1.94	(49.3)		116	0.04	(1.0)	2.47	(62.7)
1.93	(49.0)		118	0.03	(0.8)	2.46	(62.5)
1.92	(48.8)		120	0.02	(0.5)	2.45	(62.2)

**D5, 955, 951, 561 - 6.91 in. (175.5 mm)**

**Pins and Bushings <sup>(1)</sup>  
Genuine and Classic  
Internal Wear  
Sealed Track**

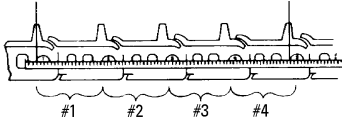

Inches	(mm)	% Worn
27.65	(702.5)	0
27.70	(703.5)	10
27.75	(705.0)	20
27.80	(706.0)	30
27.85	(707.5)	40
27.90	(708.5)	50
27.95	(710.0)	60
28.00	(711.0)	70
28.05	(712.5)	80
28.10	(713.5)	90
28.15	(715.0)	100
28.20	(716.5)	105
28.25	(717.5)	110
28.30	(719.0)	115
28.35	(720.0)	120

1 Wear Chart: 360



**Bushings <sup>(1)</sup>  
External Wear  
Sealed Track**

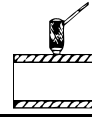

Caliper		Allowable Wear		Ultrasonic	
Inches	(mm)	Lesser % Worn	Greater % Worn	Inches	(mm)
2.33	(59.2)	0	0	0.42	(10.7)
2.32	(58.9)	10	6	0.41	(10.4)
2.31	(58.7)	20	12	0.40	(10.2)
2.30	(58.4)	30	18	0.39	(9.9)
2.29	(58.2)	40	24	0.38	(9.7)
2.28	(57.9)	50	30	0.37	(9.4)
2.27	(57.7)	60	36	0.36	(9.1)
2.26	(57.4)	70	42	0.35	(8.9)
2.25	(57.2)	75	48	0.34	(8.6)
2.24	(56.9)	80	54	0.33	(8.4)
2.23	(56.6)	85	60	0.32	(8.1)
2.22	(56.4)	90	66	0.31	(7.9)
2.21	(56.1)	95	72	0.30	(7.6)
2.20	(55.9)	100	78	0.29	(7.4)
2.19	(55.6)	105	82	0.28	(7.1)
2.18	(55.4)	110	85	0.27	(6.9)
2.17	(55.1)	115	88	0.26	(6.6)
2.16	(54.9)	120	91	0.25	(6.4)
2.15	(54.6)		94	0.24	(6.1)
2.14	(54.4)		97	0.23	(5.8)
2.13	(54.1)		100	0.22	(5.6)
2.12	(53.8)		103	0.21	(5.3)
2.11	(53.6)		106	0.20	(5.1)
2.10	(53.3)		109	0.19	(4.8)
2.09	(53.1)		112	0.18	(4.6)
2.08	(52.8)		115	0.17	(4.3)
2.07	(52.6)		118	0.16	(4.1)
2.06	(52.3)		121	0.15	(3.8)

# D5B, D6, 951, 955 - 6.91 in. (175.5 mm)

## Bushings <sup>(1)</sup> Classic External Wear Sealed Track

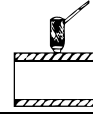

### Allowable Wear

Caliper		Lesser	Greater	Ultrasonic	
Inches	(mm)	% Worn	% Worn	Inches	(mm)
2.31	(58.7)	0	0	0.41	(10.4)
2.30	(58.4)	10	6	0.40	(10.2)
2.29	(58.2)	20	12	0.39	(9.9)
2.28	(57.9)	30	18	0.38	(9.7)
2.27	(57.7)	40	24	0.37	(9.4)
2.26	(57.4)	50	30	0.36	(9.1)
2.25	(57.2)	60	36	0.35	(8.9)
2.24	(56.9)	70	42	0.34	(8.6)
2.23	(56.6)	80	48	0.33	(8.4)
2.22	(56.4)	85	54	0.32	(8.1)
2.21	(56.1)	90	60	0.31	(7.9)
2.20	(55.9)	95	66	0.30	(7.6)
2.19	(55.6)	100	72	0.29	(7.4)
2.18	(55.4)	105	78	0.28	(7.1)
2.17	(55.1)	110	84	0.27	(6.9)
2.16	(54.9)	115	88	0.26	(6.6)
2.15	(54.6)	120	91	0.25	(6.4)
2.14	(54.4)		94	0.24	(6.1)
2.13	(54.1)		97	0.23	(5.8)
2.12	(53.8)		100	0.22	(5.6)
2.11	(53.6)		103	0.21	(5.3)
2.10	(53.3)		106	0.20	(5.1)
2.09	(53.1)		109	0.19	(4.8)
2.08	(52.8)		112	0.18	(4.6)
2.07	(52.6)		115	0.17	(4.3)
2.06	(52.3)		118	0.16	(4.1)
2.05	(52.1)		121	0.15	(3.8)

# D5, 955, 951, 561, - 6.91 in. (175.5 mm)

## Track Shoes <sup>(1)</sup> Genuine Moderate Service

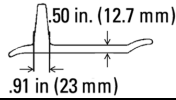
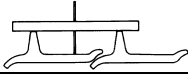

**Depth Gauge**

**Ultrasonic**

Inches	(mm)	% Worn	Inches	(mm)
2.25	(57.0)	0	2.75	(69.9)
2.20	(56.0)	4	2.70	(68.6)
2.15	(54.5)	8	2.65	(67.3)
2.10	(53.5)	12	2.60	(66.0)
2.05	(52.0)	16	2.55	(64.8)
2.00	(51.0)	20	2.50	(63.5)
1.95	(49.5)	24	2.45	(62.2)
1.90	(48.5)	28	2.40	(61.0)
1.85	(47.0)	32	2.35	(59.7)
1.80	(45.5)	36	2.30	(58.4)
1.75	(44.5)	40	2.25	(57.2)
1.70	(43.0)	44	2.20	(55.9)
1.65	(42.0)	48	2.15	(54.6)
1.60	(40.5)	52	2.10	(53.3)
1.55	(39.5)	56	2.05	(52.1)
1.50	(38.0)	60	2.00	(50.8)
1.45	(37.0)	64	1.95	(49.5)
1.40	(35.5)	67	1.90	(48.3)
1.35	(34.5)	70	1.85	(47.0)
1.30	(33.0)	73	1.80	(45.7)
1.25	(32.0)	76	1.75	(44.5)
1.20	(30.5)	79	1.70	(43.2)
1.15	(29.0)	82	1.65	(41.9)
1.10	(28.0)	85	1.60	(40.6)
1.05	(26.5)	88	1.55	(39.4)
1.00	(25.5)	91	1.50	(38.1)
0.95	(24.0)	94	1.45	(36.8)
0.90	(23.0)	97	1.40	(35.6)
0.85	(21.5)	100	1.35	(34.3)
0.80	(20.5)	103	1.30	(33.0)
0.75	(19.0)	106	1.25	(31.8)
0.70	(18.0)	109	1.20	(30.5)
0.65	(16.5)	112	1.15	(29.2)
0.60	(15.0)	115	1.10	(27.9)
0.55	(14.0)	118	1.05	(26.7)
0.50	(12.5)	121	1.00	(25.4)

# D5B, D6, 951, 955 - 6.91 in. (175.5 mm)

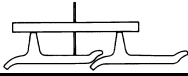
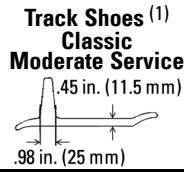

**Depth Gauge**

**Ultrasonic**

Depth Gauge		% Worn	Ultrasonic	
Inches	(mm)		Inches	(mm)
2.15	(54.5)	0	2.60	(66.0)
2.10	(53.5)	4	2.55	(64.8)
2.05	(52.0)	8	2.50	(63.5)
2.00	(51.0)	12	2.45	(62.2)
1.95	(49.5)	16	2.40	(61.0)
1.90	(48.5)	20	2.35	(59.7)
1.85	(47.0)	24	2.30	(58.4)
1.80	(45.5)	28	2.25	(57.2)
1.75	(44.5)	32	2.20	(55.9)
1.70	(43.0)	36	2.15	(54.6)
1.65	(42.0)	40	2.10	(53.3)
1.60	(40.5)	44	2.05	(52.1)
1.55	(39.5)	48	2.00	(50.8)
1.50	(38.0)	52	1.95	(49.5)
1.45	(37.0)	56	1.90	(48.3)
1.40	(35.5)	60	1.85	(47.0)
1.35	(34.5)	64	1.80	(45.7)
1.30	(33.0)	68	1.75	(44.5)
1.25	(32.0)	72	1.70	(43.2)
1.20	(30.5)	76	1.65	(41.9)
1.15	(29.0)	80	1.60	(40.6)
1.10	(28.0)	84	1.55	(39.4)
1.05	(26.5)	88	1.50	(38.1)
1.00	(25.5)	91	1.45	(36.8)
0.95	(24.0)	94	1.40	(35.6)
0.90	(23.0)	97	1.35	(34.3)
0.85	(21.5)	100	1.30	(33.0)
0.80	(20.5)	103	1.25	(31.8)
0.75	(19.0)	106	1.20	(30.5)
0.70	(18.0)	109	1.15	(29.2)
0.65	(16.5)	112	1.10	(27.9)
0.60	(15.0)	115	1.05	(26.7)
0.55	(14.0)	118	1.00	(25.4)
0.50	(12.5)	121	0.95	(24.1)

**D5, 955, 951, 561 - 6.91 in. (175.5 mm)**

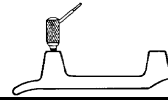
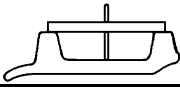
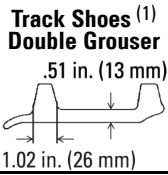

**Depth Gauge**

**Ultrasonic**

Depth Gauge		% Worn	Ultrasonic	
Inches	(mm)		Inches	(mm)
1.50	(38.0)	0	1.99	(50.5)
1.45	(37.0)	5	1.94	(49.2)
1.40	(35.5)	10	1.89	(48.0)
1.35	(34.5)	15	1.84	(46.7)
1.30	(33.0)	20	1.79	(45.4)
1.25	(32.0)	25	1.74	(44.2)
1.20	(30.5)	30	1.69	(42.9)
1.15	(29.0)	35	1.64	(41.6)
1.10	(28.0)	40	1.59	(40.3)
1.05	(26.5)	45	1.54	(39.1)
1.00	(25.5)	50	1.49	(37.8)
0.95	(24.0)	55	1.44	(36.5)
0.90	(23.0)	60	1.39	(35.3)
0.85	(21.5)	65	1.34	(34.0)
0.80	(20.5)	70	1.29	(32.7)
0.75	(19.0)	75	1.24	(31.5)
0.70	(18.0)	80	1.19	(30.2)
0.65	(16.5)	85	1.14	(28.9)
0.60	(15.0)	90	1.09	(27.6)
0.55	(14.0)	95	1.04	(26.4)
0.50	(12.5)	100	0.99	(25.1)
0.45	(11.5)	105	0.94	(23.8)
0.40	(10.0)	110	0.89	(22.6)
0.35	(9.0)	115	0.84	(21.3)
0.30	(7.5)	120	0.79	(20.0)

**D5, 955, 951, 561 - 6.91 in. (175.5 mm)**

**Track Shoes <sup>(1)</sup>  
Genuine  
Triple Grouser**

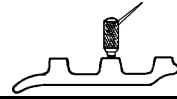
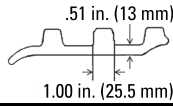
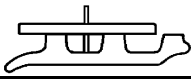

**Depth Gauge**

**Ultrasonic**

Depth Gauge		% Worn	Ultrasonic	
Inches	(mm)		Inches	(mm)
0.95	(24.0)	0	1.50	(38.1)
0.90	(23.0)	8	1.45	(36.8)
0.85	(21.5)	16	1.40	(35.6)
0.80	(20.5)	23	1.35	(34.3)
0.75	(19.0)	30	1.30	(33.0)
0.70	(18.0)	37	1.25	(31.8)
0.65	(16.5)	44	1.20	(30.5)
0.60	(15.0)	51	1.15	(29.2)
0.55	(14.0)	58	1.10	(27.9)
0.50	(12.5)	65	1.05	(26.7)
0.45	(11.5)	72	1.00	(25.4)
0.40	(10.0)	79	0.95	(24.1)
0.35	(9.0)	86	0.90	(22.9)
0.30	(7.5)	93	0.85	(21.6)
0.25	(6.5)	100	0.80	(20.3)
0.20	(5.0)	107	0.75	(19.1)
0.15	(4.0)	114	0.70	(17.8)
0.10	(2.5)	121	0.65	(16.5)

## D5B, D6, 951, 955 - 6.91 in. (175.5 mm)

### Track Shoes <sup>(1)</sup> Classic Triple Grouser

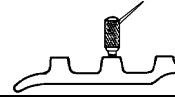
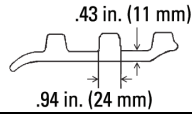
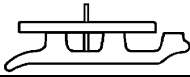

#### Depth Gauge

#### Ultrasonic

Depth Gauge		% Worn	Ultrasonic	
Inches	(mm)		Inches	(mm)
1.00	(25.5)	0	1.42	(36.0)
0.95	(24.0)	7	1.37	(34.7)
0.90	(23.0)	14	1.32	(33.5)
0.85	(21.5)	21	1.27	(32.2)
0.80	(20.5)	28	1.22	(30.9)
0.75	(19.0)	35	1.17	(29.7)
0.70	(18.0)	42	1.12	(28.4)
0.65	(16.5)	49	1.07	(27.1)
0.60	(15.0)	56	1.02	(25.8)
0.55	(14.0)	63	0.97	(24.6)
0.50	(12.5)	70	0.92	(23.3)
0.45	(11.5)	76	0.87	(22.0)
0.40	(10.0)	82	0.82	(20.8)
0.35	(9.0)	88	0.77	(19.5)
0.30	(7.5)	94	0.72	(18.2)
0.25	(6.5)	100	0.67	(17.0)
0.20	(5.0)	106	0.62	(15.7)
0.15	(4.0)	112	0.57	(14.4)
0.10	(2.5)	118	0.52	(13.1)
0.05	(1.5)	124	0.47	(11.9)

**D5, 955, 951, 561 - 6.91 in. (175.5 mm)**

**Track Shoes <sup>(1)</sup>  
Self Cleaning**

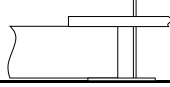
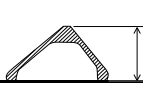

**Depth Gauge**

<b>Inches</b>	<b>(mm)</b>	<b>% Worn</b>
3.14	(80.0)	0
3.12	(79.0)	4
3.10	(78.5)	8
3.08	(78.0)	12
3.06	(77.5)	16
3.04	(77.0)	20
3.02	(76.5)	24
3.00	(76.0)	28
2.98	(75.5)	32
2.96	(75.0)	36
2.94	(74.5)	40
2.92	(74.0)	44
2.90	(73.5)	48
2.88	(73.0)	52
2.86	(72.5)	55
2.84	(72.0)	58
2.82	(71.5)	61
2.80	(71.0)	64
2.78	(70.5)	67
2.76	(70.0)	70
2.74	(69.5)	73
2.72	(69.0)	76
2.70	(68.5)	79
2.68	(68.0)	82
2.66	(67.5)	85
2.64	(67.0)	88
2.62	(66.5)	91
2.60	(66.0)	94
2.58	(65.5)	97
2.56	(65.0)	100
2.54	(64.5)	103
2.52	(64.0)	106
2.50	(63.5)	109
2.48	(63.0)	112
2.46	(62.5)	115
2.44	(62.0)	118
2.42	(61.5)	121

1 Wear Chart: 1860



**Idlers <sup>(1) (2) (3)</sup>**  
**Extended Life Idlers**  
 (Has circular side plate indentations)

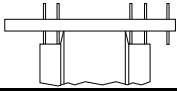

**Depth Gauge**

Inches	(mm)	% Worn
0.74	(19.0)	0
0.76	(19.5)	7
0.78	(20.0)	14
0.80	(20.5)	21
0.82	(21.0)	28
0.84	(21.5)	35
0.86	(22.0)	42
0.88	(22.5)	49
0.90	(23.0)	56
0.92	(23.5)	63
0.94	(24.0)	67
0.96	(24.5)	70
0.98	(25.0)	73
1.00	(25.5)	76
1.02	(26.0)	79
1.04	(26.5)	82
1.06	(27.0)	85
1.08	(27.5)	88
1.10	(28.0)	91
1.12	(28.5)	94
1.14	(29.0)	97
1.16	(29.5)	100
1.18	(30.0)	103
1.20	(30.5)	106
1.22	(31.0)	109
1.24	(31.5)	112
1.26	(32.0)	115
1.28	(32.5)	118
1.30	(33.0)	121



**Ultrasonic**

**Center Flange Wear**

Inches	(mm)	Inches	(mm)
0.40	(10.2)	0.00	(0.0)
0.38	(9.7)	0.02	(0.5)
0.36	(9.1)	0.04	(1.0)
0.34	(8.6)	0.06	(1.5)
0.32	(8.1)	0.08	(2.0)
0.30	(7.6)	0.10	(2.5)
0.28	(7.1)	0.12	(3.0)
0.26	(6.6)	0.14	(3.5)
0.24	(6.1)	0.16	(4.0)
0.22	(5.6)	0.18	(4.5)
0.20	(5.1)	0.20	(5.0)
0.18	(4.6)	0.22	(5.5)
0.16	(4.1)	0.24	(6.0)
0.14	(3.6)	0.26	(6.5)
0.12	(3.0)	0.28	(7.0)
0.10	(2.5)	0.30	(7.5)
0.08	(2.0)	0.32	(8.0)
0.06	(1.5)	0.34	(8.5)
0.04	(1.0)	0.36	(9.0)
0.02	(0.5)	0.38	(9.5)

**NOTE**

Ultrasonic measurement is to determine flange wear only.

- 1 Flange width is 3.31 in. (84 mm)
- 2 New tread diameter is 22.99 in. (584 mm) or 25.24 in. (641 mm)
- 3 Wear Chart: 4361

## D5, 955, 951, 561 - 6.91 in. (175.5 mm)

Idlers <sup>(1)</sup> <sup>(2)</sup> <sup>(3)</sup>  
 (Has no side plate indentations)

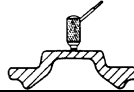
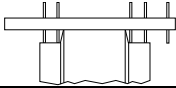

Depth Gauge		
Inches	(mm)	% Worn
0.78	(20.0)	0
0.80	(20.5)	12
0.82	(21.0)	24
0.84	(21.5)	36
0.86	(22.0)	48
0.88	(22.5)	60
0.90	(23.0)	72
0.92	(23.5)	82
0.94	(24.0)	85
0.96	(24.5)	88
0.98	(25.0)	91
1.00	(25.5)	94
1.02	(26.0)	97
1.04	(26.5)	100
1.06	(27.0)	103
1.08	(27.5)	106
1.10	(28.0)	109
1.12	(28.5)	112
1.14	(29.0)	115
1.16	(29.5)	118
1.18	(30.0)	121

Ultrasonic		Center Flange Wear	
Inches	(mm)	Inches	(mm)
0.36	(9.1)	0.00	(0.0)
0.34	(8.6)	0.02	(0.5)
0.32	(8.1)	0.04	(1.0)
0.30	(7.6)	0.06	(1.5)
0.28	(7.1)	0.08	(2.0)
0.26	(6.6)	0.10	(2.5)
0.24	(6.1)	0.12	(3.0)
0.22	(5.6)	0.14	(3.5)
0.20	(5.1)	0.16	(4.0)
0.18	(4.6)	0.18	(4.5)
0.16	(4.1)	0.20	(5.0)
0.14	(3.6)	0.22	(5.5)
0.12	(3.0)	0.24	(6.0)
0.10	(2.5)	0.26	(6.5)
0.8	(2.0)	0.28	(7.0)
0.6	(1.5)	0.30	(7.5)
0.4	(1.0)	0.32	(8.0)
0.2	(0.5)	0.34	(8.5)

### NOTE

Ultrasonic measurement is to determine flange wear only.

- 1 Flange width is 3.31 in. (84 mm)
- 2 New tread diameter is 25.26 in. (641.5 mm)
- 3 Wear Chart: 4360

Idlers <sup>(1)</sup> <sup>(2)</sup>  
Classic

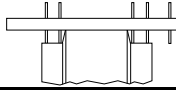

Depth Gauge

Inches	(mm)	% Worn
0.78	(20.0)	0
0.80	(20.5)	10
0.82	(21.0)	20
0.84	(21.5)	30
0.86	(22.0)	40
0.88	(22.5)	50
0.90	(23.0)	60
0.92	(23.5)	64
0.94	(24.0)	67
0.96	(24.5)	70
0.98	(25.0)	73
1.00	(25.5)	76
1.02	(26.0)	79
1.04	(26.5)	82
1.06	(27.0)	85
1.08	(27.5)	88
1.10	(28.0)	91
1.12	(28.5)	94
1.14	(29.0)	97
1.16	(29.5)	100
1.18	(30.0)	103
1.20	(30.5)	106
1.22	(31.0)	109
1.24	(31.5)	112
1.26	(32.0)	115
1.28	(32.5)	118
1.30	(33.0)	121

1 New tread diameter is 25.25 in. (641.4 mm)

2 Wear Chart: 4363

# D5, 955, 951, 561 - 6.91 in. (175.5 mm)

## Carrier Rollers <sup>(1)</sup> Use with 7T Track Links

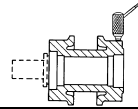
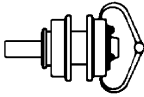

Caliper			Ultrasonic		
Inches	(mm)	% Worn	Inches	(mm)	
6.75	(171.5)	0	1.55	(39.4)	
6.71	(170.5)	4	1.53	(38.9)	
6.67	(169.5)	8	1.51	(38.4)	
6.63	(168.5)	12	1.49	(37.8)	
6.59	(167.5)	16	1.47	(37.3)	
6.55	(166.5)	20	1.45	(36.8)	
6.51	(165.5)	24	1.43	(36.3)	
6.47	(164.5)	28	1.41	(35.8)	
6.43	(163.5)	31	1.39	(35.3)	
6.39	(162.5)	34	1.37	(34.8)	
6.35	(161.5)	37	1.35	(34.3)	
6.31	(160.5)	40	1.33	(33.8)	
6.27	(159.5)	43	1.31	(33.3)	
6.23	(158.0)	46	1.29	(32.8)	
6.19	(157.0)	49	1.27	(32.3)	
6.15	(156.0)	52	1.25	(31.8)	
6.11	(155.0)	55	1.23	(31.2)	
6.07	(154.0)	58	1.21	(30.7)	
6.03	(153.0)	61	1.19	(30.2)	
5.99	(152.0)	64	1.17	(29.7)	
5.95	(151.0)	67	1.15	(29.2)	
5.91	(150.0)	70	1.13	(28.7)	
5.87	(149.0)	73	1.11	(28.2)	
5.83	(148.0)	76	1.09	(27.7)	
5.79	(147.0)	79	1.07	(27.2)	
5.75	(146.0)	82	1.05	(26.7)	
5.71	(145.0)	85	1.03	(26.2)	
5.67	(144.0)	88	1.01	(25.7)	
5.63	(143.0)	91	0.99	(25.1)	
5.59	(142.0)	94	0.97	(24.6)	
5.55	(141.0)	97	0.95	(24.1)	
5.51	(140.0)	100	0.93	(23.6)	
5.47	(139.0)	103	0.91	(23.1)	
5.43	(138.0)	106	0.89	(22.6)	
5.39	(137.0)	109	0.87	(22.1)	
5.35	(136.0)	112	0.85	(21.6)	
5.31	(135.0)	115	0.83	(21.1)	
5.27	(134.0)	118	0.81	(20.6)	
5.23	(133.0)	121	0.79	(20.1)	

1 Wear Chart: 4663

## D5, 955, 951, 561 - 6.91 in. (175.5 mm)

### Carrier Rollers <sup>(1)</sup> Use with 3P Links

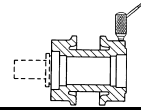
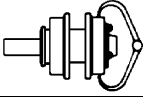

Caliper			Ultrasonic		
Inches	(mm)	% Worn	Inches	(mm)	
6.75	(171.5)	0	1.54	(39.1)	
6.71	(170.5)	7	1.52	(38.6)	
6.67	(169.5)	14	1.50	(38.1)	
6.63	(168.5)	21	1.48	(37.6)	
6.59	(167.5)	28	1.46	(37.1)	
6.55	(166.5)	35	1.44	(36.6)	
6.51	(165.5)	40	1.42	(36.1)	
6.47	(164.5)	45	1.40	(35.6)	
6.43	(163.5)	50	1.38	(35.1)	
6.39	(162.5)	55	1.36	(34.5)	
6.35	(161.5)	60	1.34	(34.0)	
6.31	(160.5)	65	1.32	(33.5)	
6.27	(159.5)	70	1.30	(33.0)	
6.23	(158.0)	75	1.28	(32.5)	
6.19	(157.0)	80	1.26	(32.0)	
6.15	(156.0)	85	1.24	(31.5)	
6.11	(155.0)	90	1.22	(31.0)	
6.07	(154.0)	95	1.20	(30.5)	
6.03	(153.0)	100	1.18	(30.0)	
5.99	(152.0)	105	1.16	(29.5)	
5.95	(151.0)	110	1.14	(29.0)	
5.91	(150.0)	115	1.12	(28.4)	
5.87	(149.0)	120	1.10	(27.9)	

# D5B, D6, 951, 955 - 6.91 in. (175.5 mm)

## Carrier Rollers <sup>(1)</sup> Classic

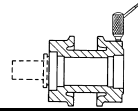
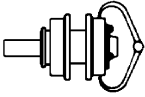

Caliper			Ultrasonic		
Inches	(mm)	% Worn	Inches	(mm)	
6.75	(171.5)	0	1.54	(39.1)	
6.71	(170.5)	6	1.52	(38.6)	
6.67	(169.5)	12	1.50	(38.1)	
6.63	(168.5)	18	1.48	(37.6)	
6.59	(167.5)	24	1.46	(37.1)	
6.55	(166.5)	30	1.44	(36.6)	
6.51	(165.5)	36	1.42	(36.1)	
6.47	(164.5)	42	1.40	(35.6)	
6.43	(163.5)	48	1.38	(35.1)	
6.39	(162.5)	54	1.36	(34.5)	
6.35	(161.5)	60	1.34	(34.0)	
6.31	(160.5)	66	1.32	(33.5)	
6.27	(159.5)	72	1.30	(33.0)	
6.23	(158.0)	78	1.28	(32.5)	
6.19	(157.0)	84	1.26	(32.0)	
6.15	(156.0)	90	1.24	(31.5)	
6.11	(155.0)	96	1.22	(31.0)	
6.07	(154.0)	100	1.20	(30.5)	
6.03	(153.0)	104	1.18	(30.0)	
5.99	(152.0)	108	1.16	(29.5)	
5.95	(151.0)	112	1.14	(29.0)	
5.91	(150.0)	116	1.12	(28.4)	
5.87	(149.0)	120	1.10	(27.9)	

1 Wear Chart: 4662

## D5, 955, 951, 561 - 6.91 in. (175.5 mm)

### Track Rollers <sup>(1) (2)</sup> Extended Life Rollers Use with 7T Links

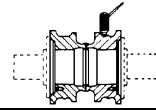
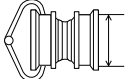

Caliper			Depth Gauge		Ultrasonic	
Inches	(mm)	% Worn	Inches	(mm)	Inches	(mm)
8.38	(213.0)	0	0.57	(14.5)	2.07	(52.6)
8.30	(211.0)	8	0.61	(15.5)	2.03	(51.6)
8.22	(209.0)	16	0.65	(16.5)	1.99	(50.5)
8.14	(207.0)	24	0.69	(17.5)	1.95	(49.5)
8.06	(204.5)	32	0.73	(18.5)	1.91	(48.5)
7.98	(202.5)	40	0.77	(19.5)	1.87	(47.5)
7.90	(200.5)	48	0.81	(20.5)	1.83	(46.5)
7.82	(198.5)	56	0.85	(21.5)	1.79	(45.5)
7.74	(196.5)	64	0.89	(22.5)	1.75	(44.5)
7.66	(194.5)	68	0.93	(23.5)	1.71	(43.4)
7.58	(192.5)	72	0.97	(24.5)	1.67	(42.4)
7.50	(190.5)	76	1.01	(25.5)	1.63	(41.4)
7.42	(188.5)	80	1.05	(26.5)	1.59	(40.4)
7.34	(186.5)	84	1.09	(27.5)	1.55	(39.4)
7.26	(184.5)	88	1.13	(28.5)	1.51	(38.4)
7.18	(182.5)	92	1.17	(29.5)	1.47	(37.3)
7.10	(180.5)	96	1.21	(30.5)	1.43	(36.3)
7.02	(178.5)	100	1.25	(32.0)	1.39	(35.3)
6.94	(176.5)	104	1.29	(33.0)	1.35	(34.3)
6.86	(174.0)	108	1.33	(34.0)	1.31	(33.3)
6.78	(172.0)	112	1.37	(35.0)	1.27	(32.3)
6.70	(170.0)	116	1.41	(36.0)	1.23	(31.2)
6.62	(168.0)	120	1.45	(37.0)	1.19	(30.2)

1 Flange diameter is 9.53 in. (242 mm)

2 Wear Chart: 5264

# D5, 955, 951, 561 - 6.91 in. (175.5 mm)

## Track Rollers <sup>(1) (2)</sup> Use with 3P Links

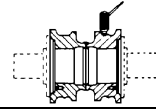

Caliper			Depth Gauge		Ultrasonic	
Inches	(mm)	% Worn	Inches	(mm)	Inches	(mm)
8.01	(203.5)	0	0.65	(16.5)	1.88	(47.8)
7.97	(202.5)	6	0.67	(17.0)	1.86	(47.2)
7.93	(201.5)	12	0.69	(17.5)	1.84	(46.7)
7.89	(200.5)	18	0.71	(18.0)	1.82	(46.2)
7.85	(199.5)	24	0.73	(18.5)	1.80	(45.7)
7.81	(198.5)	30	0.75	(19.0)	1.78	(45.2)
7.77	(197.5)	36	0.77	(19.5)	1.76	(44.7)
7.73	(196.5)	42	0.79	(20.0)	1.74	(44.2)
7.69	(195.5)	48	0.81	(20.5)	1.72	(43.7)
7.65	(194.5)	54	0.83	(21.0)	1.70	(43.2)
7.61	(193.5)	60	0.85	(21.5)	1.68	(42.7)
7.57	(192.5)	66	0.87	(22.0)	1.66	(42.2)
7.53	(191.5)	72	0.89	(22.5)	1.64	(41.7)
7.49	(190.0)	76	0.91	(23.0)	1.62	(41.1)
7.45	(189.0)	80	0.93	(23.5)	1.60	(40.6)
7.41	(188.0)	84	0.95	(24.0)	1.58	(40.1)
7.37	(187.0)	88	0.97	(24.5)	1.56	(39.6)
7.33	(186.0)	92	0.99	(25.0)	1.54	(39.1)
7.29	(185.0)	96	1.01	(25.5)	1.52	(38.6)
7.25	(184.0)	100	1.03	(26.0)	1.50	(38.1)
7.21	(183.0)	104	1.05	(26.5)	1.48	(37.6)
7.17	(182.0)	108	1.07	(27.0)	1.46	(37.1)
7.13	(181.0)	112	1.09	(27.5)	1.44	(36.6)
7.09	(180.0)	116	1.11	(28.0)	1.42	(36.1)
7.05	(179.0)	120	1.13	(28.5)	1.40	(35.6)

1 Flange diameter is 9.31 in. (236 mm)

2 Wear Chart: 5260



## D5B, D6, 951, 955 - 6.91 in. (175.5 mm)

### Track Rollers <sup>(1) (2)</sup> Classic

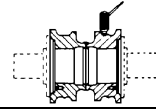
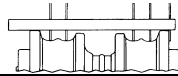
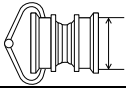

Caliper			Depth Gauge		Ultrasonic	
Inches	(mm)	% Worn	Inches	(mm)	Inches	(mm)
7.99	(203.0)	0	0.57	(14.5)	1.88	(47.8)
7.95	(202.0)	6	0.59	(15.0)	1.86	(47.2)
7.91	(201.0)	12	0.61	(15.5)	1.84	(46.7)
7.87	(200.0)	18	0.63	(16.0)	1.82	(46.2)
7.83	(199.0)	24	0.65	(16.5)	1.80	(45.7)
7.79	(198.0)	30	0.67	(17.0)	1.78	(45.2)
7.75	(197.0)	36	0.69	(17.5)	1.76	(44.7)
7.71	(196.0)	42	0.71	(18.0)	1.74	(44.2)
7.67	(195.0)	48	0.73	(18.5)	1.72	(43.7)
7.63	(194.0)	54	0.75	(19.0)	1.70	(43.2)
7.59	(193.0)	60	0.77	(19.5)	1.68	(42.7)
7.55	(192.0)	64	0.79	(20.0)	1.66	(42.2)
7.51	(191.0)	68	0.81	(20.5)	1.64	(41.7)
7.47	(189.5)	72	0.83	(21.0)	1.62	(41.1)
7.43	(188.5)	76	0.85	(21.5)	1.60	(40.6)
7.39	(187.5)	80	0.87	(22.0)	1.58	(40.1)
7.35	(186.5)	84	0.89	(22.5)	1.56	(39.6)
7.31	(185.5)	88	0.91	(23.0)	1.54	(39.1)
7.27	(184.5)	92	0.93	(23.5)	1.52	(38.6)
7.23	(183.5)	96	0.95	(24.0)	1.50	(38.1)
7.19	(182.5)	100	0.97	(24.5)	1.48	(37.6)
7.15	(181.5)	104	0.99	(25.0)	1.46	(37.1)
7.11	(180.5)	108	1.01	(25.5)	1.44	(36.6)
7.07	(179.5)	112	1.03	(26.0)	1.42	(36.1)
7.03	(178.5)	116	1.05	(26.5)	1.40	(35.6)
6.99	(177.5)	120	1.07	(27.0)	1.38	(35.1)

1 Flange diameter is 9.13 in. (232 mm)

2 Wear Chart: 5267

# D6K, D6K2, PL61 - 7.50 in. (190 mm)

## Track Links <sup>(1)</sup> SystemOne Track 235-2529

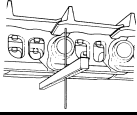

Depth Gauge			Ultrasonic	
Inches	(mm)	% Worn	Inches	(mm)
4.25	(108.0)	0	1.14	(29.0)
4.23	(107.5)	6	1.12	(28.4)
4.21	(107.0)	12	1.10	(27.9)
4.19	(106.5)	18	1.08	(27.4)
4.17	(106.0)	24	1.06	(26.9)
4.15	(105.5)	30	1.04	(26.4)
4.13	(105.0)	35	1.02	(25.9)
4.11	(104.5)	40	1.00	(25.4)
4.09	(104.0)	45	0.98	(24.9)
4.07	(103.5)	50	0.96	(24.4)
4.05	(103.0)	55	0.94	(23.9)
4.03	(102.5)	60	0.92	(23.4)
4.01	(102.0)	65	0.90	(22.9)
3.99	(101.5)	70	0.88	(22.4)
3.97	(101.0)	75	0.86	(21.8)
3.95	(100.5)	80	0.84	(21.3)
3.93	(100.0)	85	0.82	(20.8)
3.91	(99.5)	90	0.80	(20.3)
3.89	(99.0)	95	0.78	(19.8)
3.87	(98.5)	100	0.76	(19.3)
3.85	(98.0)	105	0.74	(18.8)
3.83	(97.5)	110	0.72	(18.3)
3.81	(97.0)	115	0.70	(17.8)
3.79	(96.5)	120	0.68	(17.3)

# D6K, D6K2, PL61 - 7.50 in. (190 mm)

## Track Links <sup>(1)</sup> Heavy Duty Track 106-1625 & 26

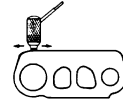
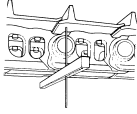

Depth Gauge			Ultrasonic	
In	mm	% Worn	In	mm
4.68	(119.0)	0	1.53	(38.9)
4.66	(118.5)	6	1.51	(38.4)
4.64	(118.0)	12	1.49	(37.8)
4.62	(117.5)	18	1.47	(37.3)
4.60	(117.0)	24	1.45	(36.8)
4.58	(116.5)	30	1.43	(36.3)
4.56	(116.0)	35	1.41	(35.8)
4.54	(115.5)	40	1.39	(35.3)
4.52	(115.0)	45	1.37	(34.8)
4.50	(114.5)	50	1.35	(34.3)
4.48	(114.0)	55	1.33	(33.8)
4.46	(113.5)	60	1.31	(33.3)
4.44	(113.0)	65	1.29	(32.8)
4.42	(112.5)	70	1.27	(32.3)
4.40	(112.0)	75	1.25	(31.8)
4.38	(111.5)	80	1.23	(31.2)
4.36	(110.5)	85	1.21	(30.7)
4.34	(110.0)	90	1.19	(30.2)
4.32	(109.5)	95	1.17	(29.7)
4.30	(109.0)	100	1.15	(29.2)
4.28	(108.5)	105	1.13	(28.7)
4.26	(108.0)	110	1.11	(28.2)
4.24	(107.5)	115	1.09	(27.7)
4.22	(107.0)	120	1.07	(27.2)

# D6K, D6K2, PL61 - 7.50 in. (190 mm)

## Bushings <sup>(1)</sup> External Wear SystemOne Track

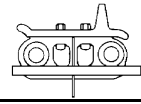
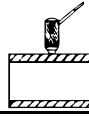
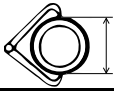

Caliper			Ultrasonic		Depth Gauge	
Inches	(mm)	% Worn	Inches	(mm)	Inches	(mm)
2.39	(60.7)	0	0.43	(10.9)	3.04	(77.2)
2.37	(60.2)	6	0.42	(10.7)	3.03	(77.0)
2.35	(59.7)	12	0.41	(10.4)	3.02	(76.7)
2.33	(59.2)	18	0.40	(10.2)	3.01	(76.5)
2.31	(58.7)	24	0.39	(9.9)	3.00	(76.2)
2.29	(58.2)	30	0.38	(9.7)	2.99	(75.9)
2.27	(57.7)	36	0.37	(9.4)	2.98	(75.7)
2.25	(57.2)	42	0.36	(9.1)	2.97	(75.4)
2.23	(56.6)	48	0.35	(8.9)	2.96	(75.2)
2.21	(56.1)	54	0.34	(8.6)	2.95	(74.9)
2.19	(55.6)	60	0.33	(8.4)	2.94	(74.7)
2.17	(55.1)	66	0.32	(8.1)	2.93	(74.4)
2.15	(54.6)	70	0.31	(7.9)	2.92	(74.2)
2.13	(54.1)	73	0.30	(7.6)	2.91	(73.9)
2.11	(53.6)	76	0.29	(7.4)	2.90	(73.7)
2.09	(53.1)	79	0.28	(7.1)	2.89	(73.4)
2.07	(52.6)	82	0.27	(6.9)	2.88	(73.2)
2.05	(52.1)	85	0.26	(6.6)	2.87	(72.9)
2.03	(51.6)	88	0.25	(6.4)	2.86	(72.6)
2.01	(51.1)	91	0.24	(6.1)	2.85	(72.4)
1.99	(50.5)	94	0.23	(5.8)	2.84	(72.1)
1.97	(50.0)	97	0.22	(5.6)	2.83	(71.9)
1.95	(49.5)	100	0.21	(5.3)	2.82	(71.6)
1.93	(49.0)	103	0.20	(5.1)	2.81	(71.4)
1.91	(48.5)	106	0.19	(4.8)	2.80	(71.1)
1.89	(48.0)	109	0.18	(4.6)	2.79	(70.9)
1.87	(47.5)	112	0.17	(4.3)	2.78	(70.6)
1.85	(47.0)	115	0.16	(4.1)	2.77	(70.4)
1.83	(46.5)	118	0.15	(3.8)	2.76	(70.1)
1.81	(46.0)	121	0.14	(3.6)	2.75	(69.9)

# D6K, D6K2, PL61 - 7.50 in. (190 mm)

## Bushings <sup>(1)</sup> Heavy Duty Track

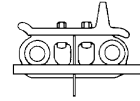
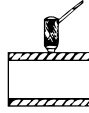
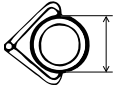

### Allowable Wear

Caliper		Lesser % Worn	Greater % Worn	Ultrasonic		Depth Gauge	
Inches	(mm)			Inches	(mm)	Inches	(mm)
2.56	(65.0)	0	0	0.51	(13.0)	3.19	(81.0)
2.54	(64.5)	10	8	0.49	(12.4)	3.17	(80.5)
2.52	(64.0)	20	16	0.47	(11.9)	3.15	(80.0)
2.50	(63.5)	30	24	0.45	(11.4)	3.13	(79.5)
2.48	(63.0)	40	32	0.43	(10.9)	3.11	(79.0)
2.46	(62.5)	50	40	0.41	(10.4)	3.09	(78.5)
2.44	(62.0)	60	48	0.39	(9.9)	3.07	(78.0)
2.42	(61.5)	70	52	0.37	(9.4)	3.05	(77.5)
2.40	(61.0)	76	56	0.35	(8.9)	3.03	(77.0)
2.38	(60.5)	80	60	0.33	(8.4)	3.01	(76.5)
2.36	(59.9)	84	64	0.31	(7.9)	2.99	(75.9)
2.34	(59.4)	88	68	0.29	(7.4)	2.97	(75.4)
2.32	(58.9)	92	72	0.27	(6.9)	2.95	(74.9)
2.30	(58.4)	96	76	0.25	(6.3)	2.93	(74.4)
2.28	(57.9)	100	80	0.23	(5.8)	2.91	(73.9)
2.26	(57.4)	104	84	0.21	(5.3)	2.89	(73.4)
2.24	(56.9)	108	88	0.19	(4.8)	2.87	(72.9)
2.22	(56.4)	112	92	0.17	(4.3)	2.85	(72.4)
2.20	(55.9)	116	96	0.15	(3.8)	2.83	(71.9)
2.18	(55.4)	120	100	0.13	(3.3)	2.81	(71.4)
2.16	(54.9)		104	0.11	(2.8)	2.79	(70.9)
2.14	(54.4)		108	0.09	(2.3)	2.77	(70.4)
2.12	(53.8)		112	0.07	(1.8)	2.75	(69.9)
2.10	(53.3)		116	0.05	(1.3)	2.73	(69.3)
2.08	(52.8)		120	0.03	(0.8)	2.71	(68.8)

# D6K, D6K2, PL61 - 7.50 in. (190 mm)

## Track Shoes <sup>(1)</sup> Extreme Service

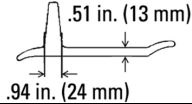
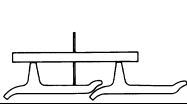

### Depth Gauge

### Ultrasonic

Inches	(mm)	% Worn	Inches	(mm)
2.25	(57.0)	0	2.75	(69.9)
2.20	(56.0)	4	2.70	(68.6)
2.15	(54.5)	8	2.65	(67.4)
2.10	(53.5)	12	2.60	(66.1)
2.05	(52.0)	16	2.55	(64.8)
2.00	(51.0)	20	2.50	(63.6)
1.95	(49.5)	24	2.45	(62.3)
1.90	(48.5)	28	2.40	(61.0)
1.85	(47.0)	32	2.35	(59.7)
1.80	(45.5)	36	2.30	(58.5)
1.75	(44.5)	40	2.25	(57.2)
1.70	(43.0)	44	2.20	(55.9)
1.65	(42.0)	48	2.15	(54.7)
1.60	(40.5)	52	2.10	(53.4)
1.55	(39.5)	56	2.05	(52.1)
1.50	(38.0)	60	2.00	(50.9)
1.45	(37.0)	64	1.95	(49.6)
1.40	(35.5)	67	1.90	(48.3)
1.35	(34.5)	70	1.85	(47.0)
1.30	(33.0)	73	1.80	(45.8)
1.25	(32.0)	76	1.75	(44.5)
1.20	(30.5)	79	1.70	(43.2)
1.15	(29.0)	82	1.65	(42.0)
1.10	(28.0)	85	1.60	(40.7)
1.05	(26.5)	88	1.55	(39.4)
1.00	(25.5)	91	1.50	(38.2)
0.95	(24.0)	94	1.45	(36.9)
0.90	(23.0)	97	1.40	(35.6)
0.85	(21.5)	100	1.35	(34.3)
0.80	(20.5)	103	1.30	(33.1)
0.75	(19.0)	106	1.25	(31.8)
0.70	(18.0)	109	1.20	(30.5)
0.65	(16.5)	112	1.15	(29.3)
0.60	(15.0)	115	1.10	(28.0)
0.55	(14.0)	118	1.05	(26.7)
0.50	(12.5)	121	1.00	(25.5)

# D6K, D6K2, PL61 - 7.50 in. (190 mm)

## Track Shoes <sup>(1)</sup> Moderate Service

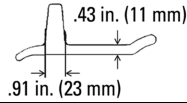
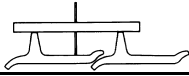

### Depth Gauge

### Ultrasonic

Inches	(mm)	% Worn	Inches	(mm)
1.85	(47.0)	0	2.30	(58.4)
1.80	(45.5)	5	2.25	(57.2)
1.75	(44.5)	10	2.20	(55.9)
1.70	(43.0)	15	2.15	(54.6)
1.65	(42.0)	20	2.10	(53.3)
1.60	(40.5)	25	2.05	(52.1)
1.55	(39.5)	30	2.00	(50.8)
1.50	(38.0)	35	1.95	(49.5)
1.45	(37.0)	40	1.90	(48.3)
1.40	(35.5)	45	1.85	(47.0)
1.35	(34.5)	50	1.80	(45.7)
1.30	(33.0)	55	1.75	(44.5)
1.25	(32.0)	60	1.70	(43.2)
1.20	(30.5)	64	1.65	(41.9)
1.15	(29.0)	68	1.60	(40.6)
1.10	(28.0)	72	1.55	(39.4)
1.05	(26.5)	76	1.50	(38.1)
1.00	(25.5)	80	1.45	(36.8)
0.95	(24.0)	84	1.40	(35.6)
0.90	(23.0)	88	1.35	(34.3)
0.85	(21.5)	92	1.30	(33.0)
0.80	(20.5)	96	1.25	(31.8)
0.75	(19.0)	100	1.20	(30.5)
0.70	(18.0)	104	1.15	(29.2)
0.65	(16.5)	108	1.10	(27.9)
0.60	(15.0)	112	1.05	(26.7)
0.55	(14.0)	116	1.00	(25.4)
0.50	(12.5)	120	0.95	(24.1)

# D6K, D6K2, PL61 - 7.50 in. (190 mm)

Track Shoes <sup>(1)</sup>  
**Double Grouser**  
 .51 in. (13 mm)  
 1.02 in. (26 mm)

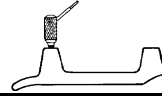
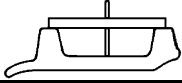

Depth Gauge			Ultrasonic	
Inches	(mm)	% Worn	Inches	(mm)
1.40	(35.5)	0	1.89	(48.0)
1.35	(34.5)	6	1.84	(46.7)
1.30	(33.0)	12	1.79	(45.5)
1.25	(32.0)	18	1.74	(44.2)
1.20	(30.5)	24	1.69	(42.9)
1.15	(29.0)	30	1.64	(41.7)
1.10	(28.0)	36	1.59	(40.4)
1.05	(26.5)	42	1.54	(39.1)
1.00	(25.5)	48	1.49	(37.8)
0.95	(24.0)	54	1.44	(36.6)
0.90	(23.0)	60	1.39	(35.3)
0.85	(21.5)	65	1.34	(34.0)
0.80	(20.5)	70	1.29	(32.8)
0.75	(19.0)	75	1.24	(31.5)
0.70	(18.0)	80	1.19	(30.2)
0.65	(16.5)	85	1.14	(29.0)
0.60	(15.0)	90	1.09	(27.7)
0.55	(14.0)	95	1.04	(26.4)
0.50	(12.5)	100	0.99	(25.1)
0.45	(11.5)	105	0.94	(23.9)
0.40	(10.0)	110	0.89	(22.6)
0.35	(9.0)	115	0.84	(21.3)
0.30	(7.5)	120	0.79	(20.1)



# D6K, D6K2, PL61 - 7.50 in. (190 mm)

Track Shoes <sup>(1)</sup>  
Self Cleaning

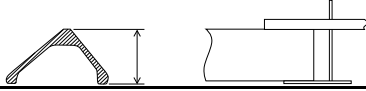

Depth Gauge

Inches	(mm)	% Worn
3.30	(84.0)	0
3.28	(83.5)	4
3.26	(83.0)	8
3.24	(82.5)	12
3.22	(82.0)	16
3.20	(81.5)	20
3.18	(81.0)	24
3.16	(80.5)	28
3.14	(80.0)	32
3.12	(79.0)	36
3.10	(78.5)	40
3.08	(78.0)	44
3.06	(77.5)	48
3.04	(77.0)	52
3.02	(76.5)	55
3.00	(76.0)	58
2.98	(75.5)	61
2.96	(75.0)	64
2.94	(74.5)	67
2.92	(74.0)	70
2.90	(73.5)	73
2.88	(73.0)	76
2.86	(72.5)	79
2.84	(72.0)	82
2.82	(71.5)	85
2.80	(71.0)	88
2.78	(70.5)	91
2.76	(70.0)	94
2.74	(69.5)	97
2.72	(69.0)	100
2.70	(68.5)	103
2.68	(68.0)	106
2.66	(67.5)	109
2.64	(67.0)	112
2.62	(66.5)	115
2.60	(66.0)	118
2.58	(65.5)	121

# D6K, D6K2, PL61 - 7.50 in. (190 mm)

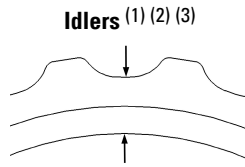

Relieved Sprocketed Idler			Sprocketed Idler	
Depth Gauge, Caliper, or Tape				
Inches	(mm)	% Worn	Inches	(mm)
1.78	(45.0)	0	0.62	(15.5)
1.76	(44.5)	5	0.60	(15.0)
1.74	(44.0)	10	0.58	(14.5)
1.72	(43.5)	15	0.56	(14.0)
1.70	(43.0)	20	0.54	(13.5)
1.68	(42.5)	24	0.52	(13.0)
1.66	(42.0)	28	0.50	(12.5)
1.64	(41.5)	32	0.48	(12.0)
1.62	(41.0)	36	0.46	(11.5)
1.60	(40.5)	40	0.44	(11.0)
1.58	(40.0)	44	0.42	(10.5)
1.56	(39.5)	48	0.40	(10.0)
1.54	(39.0)	52	0.38	(9.5)
1.52	(38.5)	56	0.36	(9.0)
1.50	(38.0)	60	0.34	(8.5)
1.48	(37.5)	64	0.32	(8.0)
1.46	(37.0)	68	0.30	(7.5)
1.44	(36.5)	72	0.28	(7.0)
1.42	(36.0)	76	0.26	(6.5)
1.40	(35.5)	80	0.24	(6.0)
1.38	(35.0)	84	0.22	(5.5)
1.36	(34.5)	88	0.20	(5.0)
1.34	(34.0)	92	0.18	(4.5)
1.32	(33.5)	96	0.16	(4.0)
1.30	(33.0)	100	0.14	(3.5)
1.28	(32.5)	104	0.12	(3.0)
1.26	(32.0)	108	0.10	(2.5)
1.24	(31.5)	112	0.08	(2.0)
1.22	(31.0)	116	0.06	(1.5)
1.20	(30.5)	120	0.04	(1.0)

- 1 New tread diameter is 23.21 in. (590 mm)
- 2 For measuring instructions, Sprocketed Center Tread Idlers and Relieved Sprocketed Center Tread Idlers [on, page 288](#) .
- 3 Wear Chart: 4081

# D6K, D6K2, PL61 - 7.50 in. (190 mm)

## Idlers (1) (2) (3) Heavy Duty

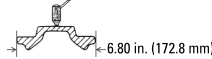
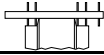

Depth Gauge		
Inches	(mm)	% Worn
0.94	(24.0)	0
0.96	(24.5)	4
0.98	(25.0)	8
1.00	(25.5)	12
1.02	(26.0)	16
1.04	(26.5)	20
1.06	(27.0)	24
1.08	(27.5)	28
1.10	(28.0)	32
1.12	(28.5)	36
1.14	(29.0)	40
1.16	(29.5)	44
1.18	(30.0)	48
1.20	(30.5)	52
1.22	(31.0)	56
1.24	(31.5)	60
1.26	(32.0)	64
1.28	(32.5)	68
1.30	(33.0)	72
1.32	(33.5)	76
1.34	(34.0)	78
1.36	(34.5)	80
1.38	(35.0)	82
1.40	(35.5)	84
1.42	(36.0)	86
1.44	(36.5)	88
1.46	(37.0)	90
1.48	(37.5)	92
1.50	(38.0)	94
1.52	(38.5)	96
1.54	(39.0)	98
1.56	(39.5)	100
1.58	(40.0)	102
1.60	(40.5)	104
1.62	(41.0)	106
1.64	(41.5)	108
1.66	(42.0)	110
1.68	(42.5)	112
1.70	(43.0)	114
1.72	(43.5)	116
1.74	(44.0)	118
1.76	(44.5)	120

Ultrasonic		Center Flange Wear	
Inches	(mm)	Inches	(mm)
0.40	(10.2)	0.00	(0.0)
0.38	(9.7)	0.02	(0.5)
0.36	(9.1)	0.04	(1.0)
0.34	(8.6)	0.06	(1.5)
0.32	(8.1)	0.08	(2.0)
0.30	(7.6)	0.10	(2.5)
0.28	(7.1)	0.12	(3.0)
0.26	(6.6)	0.14	(3.5)
0.24	(6.1)	0.16	(4.0)
0.22	(5.6)	0.18	(4.5)
0.20	(5.1)	0.20	(5.0)
0.18	(4.6)	0.22	(5.5)
0.16	(4.1)	0.24	(6.0)
0.14	(3.6)	0.26	(6.5)
0.12	(3.0)	0.28	(7.0)
0.10	(2.5)	0.30	(7.5)
0.08	(2.0)	0.32	(8.0)
0.06	(1.5)	0.34	(8.5)
0.04	(1.0)	0.36	(9.0)
0.02	(0.5)	0.38	(9.5)

### NOTE

Ultrasonic measurement is to determine flange wear only.

- 1 Flange width is 3.43 in. (87 mm)
- 2 New tread diameter is 19.92 in. (506 mm)
- 3 Wear Chart: 4385

# D6K, D6K2, PL61 - 7.50 in. (190 mm)

## Carrier Rollers <sup>(1)</sup> Permanently Sealed Use with SystemOne and Heavy Duty Track

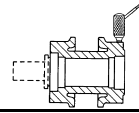
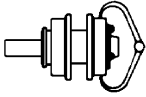

Caliper All			Ultrasonic One-piece Rim		
Inches	(mm)	% Worn	Inches	(mm)	
6.64	(168.5)	0	1.84	(46.7)	
6.58	(167.0)	5	1.81	(46.0)	
6.52	(165.5)	10	1.78	(45.2)	
6.46	(164.0)	15	1.75	(44.5)	
6.40	(162.5)	20	1.72	(43.7)	
6.34	(161.0)	25	1.69	(42.9)	
6.28	(159.5)	30	1.66	(42.2)	
6.22	(158.0)	35	1.63	(41.4)	
6.16	(156.5)	40	1.60	(40.6)	
6.10	(155.0)	45	1.57	(39.9)	
6.04	(153.5)	50	1.54	(39.1)	
5.98	(152.0)	55	1.51	(38.4)	
5.92	(150.5)	60	1.48	(37.6)	
5.86	(149.0)	65	1.45	(36.8)	
5.80	(147.5)	70	1.42	(36.1)	
5.74	(146.0)	75	1.39	(35.3)	
5.68	(144.5)	79	1.36	(34.5)	
5.62	(142.5)	82	1.33	(33.8)	
5.56	(141.0)	85	1.30	(33.0)	
5.50	(139.5)	88	1.27	(32.3)	
5.44	(138.0)	91	1.24	(31.5)	
5.38	(136.5)	94	1.21	(30.7)	
5.32	(135.0)	97	1.18	(30.0)	
5.26	(133.5)	100	1.15	(29.2)	
5.20	(132.0)	103	1.12	(28.4)	
5.14	(130.5)	106	1.09	(27.7)	
5.08	(129.0)	109	1.06	(26.9)	
5.02	(127.5)	112	1.03	(26.2)	
4.96	(126.0)	115	1.00	(25.4)	
4.90	(124.5)	118	0.97	(24.6)	
4.84	(123.0)	121	0.94	(23.9)	

1 Wear Chart: 4686

# D6K, D6K2, PL61 - 7.50 in. (190 mm)

## Track Rollers <sup>(1) (2)</sup> Use with SystemOne and Heavy Duty Track

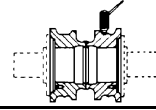
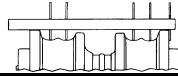
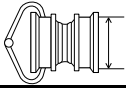

Caliper			Depth Gauge		Ultrasonic	
Inches	(mm)	% Worn	Inches	(mm)	Inches	(mm)
6.91	(175.5)	0	0.67	(17.0)	1.50	(38.1)
6.87	(174.5)	4	0.69	(17.5)	1.48	(37.6)
6.83	(173.5)	8	0.71	(18.0)	1.46	(37.1)
6.79	(172.5)	12	0.73	(18.5)	1.44	(36.6)
6.75	(171.5)	16	0.75	(19.0)	1.42	(36.1)
6.71	(170.5)	20	0.77	(19.5)	1.40	(35.6)
6.67	(169.5)	24	0.79	(20.0)	1.38	(35.1)
6.63	(168.5)	28	0.81	(20.5)	1.36	(34.5)
6.59	(167.5)	32	0.83	(21.0)	1.34	(34.0)
6.55	(166.5)	36	0.85	(21.5)	1.32	(33.5)
6.51	(165.5)	40	0.87	(22.0)	1.30	(33.0)
6.47	(164.5)	43	0.89	(22.5)	1.28	(32.5)
6.43	(163.5)	46	0.91	(23.0)	1.26	(32.0)
6.39	(162.5)	49	0.93	(23.5)	1.24	(31.5)
6.35	(161.5)	52	0.95	(24.0)	1.22	(31.0)
6.31	(160.5)	55	0.97	(24.5)	1.20	(30.5)
6.27	(159.5)	58	0.99	(25.0)	1.18	(30.0)
6.23	(158.0)	61	1.01	(25.5)	1.16	(29.5)
6.19	(157.0)	64	1.03	(26.0)	1.14	(29.0)
6.15	(156.0)	67	1.05	(26.5)	1.12	(28.4)
6.11	(155.0)	70	1.07	(27.0)	1.10	(27.9)
6.07	(154.0)	73	1.09	(27.5)	1.08	(27.4)
6.03	(153.0)	76	1.11	(28.0)	1.06	(26.9)
5.99	(152.0)	79	1.13	(28.5)	1.04	(26.4)
5.95	(151.0)	82	1.15	(29.0)	1.02	(25.9)
5.91	(150.0)	85	1.17	(29.5)	1.00	(25.4)
5.87	(149.0)	88	1.19	(30.0)	0.98	(24.9)
5.83	(148.0)	91	1.21	(30.5)	0.96	(24.4)
5.79	(147.0)	94	1.23	(31.0)	0.94	(23.9)
5.75	(146.0)	97	1.25	(32.0)	0.92	(23.4)
5.71	(145.0)	100	1.27	(32.5)	0.90	(22.9)
5.67	(144.0)	103	1.29	(33.0)	0.88	(22.4)
5.63	(143.0)	106	1.31	(33.5)	0.86	(21.8)
5.59	(142.0)	109	1.33	(34.0)	0.84	(21.3)
5.55	(141.0)	112	1.35	(34.5)	0.82	(20.8)
5.51	(140.0)	115	1.37	(35.0)	0.80	(20.3)
5.47	(139.0)	118	1.39	(35.5)	0.78	(19.8)
5.43	(138.0)	121	1.41	(36.0)	0.76	(19.3)

- 1 Flange diameter is 8.25 in. (209.5 mm)
- 2 Wear Chart: 5289

# D6, 955 - 8.00 in. (203.2 mm)

## Track Links <sup>(1)</sup> 8E-7405 & 06 or 378-8241 & 42 Heavy Duty Links

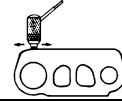
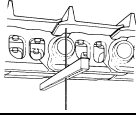

Depth Gauge			Ultrasonic		
Inches	(mm)	% Worn	Inches	(mm)	
5.19	(132.0)	0	1.69	(42.9)	
5.17	(131.5)	4	1.67	(42.4)	
5.15	(131.0)	8	1.65	(41.9)	
5.13	(130.5)	12	1.63	(41.4)	
5.11	(130.0)	16	1.61	(40.9)	
5.09	(129.5)	20	1.59	(40.4)	
5.07	(129.0)	24	1.57	(39.9)	
5.05	(128.5)	28	1.55	(39.4)	
5.03	(128.0)	32	1.53	(38.9)	
5.01	(127.5)	36	1.51	(38.4)	
4.99	(126.5)	40	1.49	(37.8)	
4.97	(126.0)	44	1.47	(37.3)	
4.95	(125.5)	48	1.45	(36.8)	
4.93	(125.0)	52	1.43	(36.3)	
4.91	(124.5)	56	1.41	(35.8)	
4.89	(124.0)	60	1.39	(35.3)	
4.87	(123.5)	64	1.37	(34.8)	
4.85	(123.0)	68	1.35	(34.3)	
4.83	(122.5)	72	1.33	(33.8)	
4.81	(122.0)	76	1.31	(33.3)	
4.79	(121.5)	80	1.29	(32.8)	
4.77	(121.0)	84	1.27	(32.3)	
4.75	(120.5)	88	1.25	(31.8)	
4.73	(120.0)	91	1.23	(31.2)	
4.71	(119.5)	94	1.21	(30.7)	
4.69	(119.0)	97	1.19	(30.2)	
4.67	(118.5)	100	1.17	(29.7)	
4.65	(118.0)	103	1.15	(29.2)	
4.63	(117.5)	106	1.13	(28.7)	
4.61	(117.0)	109	1.11	(28.2)	
4.59	(116.5)	112	1.09	(27.7)	
4.57	(116.0)	115	1.07	(27.2)	
4.55	(115.5)	118	1.05	(26.7)	
4.53	(115.0)	121	1.03	(26.2)	

Track Links <sup>(1)</sup>  
Enhanced SALT Track  
228-2735 & 36

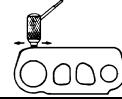
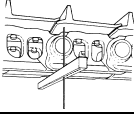

Depth Gauge			Ultrasonic	
Inches	(mm)	% Worn	Inches	(mm)
5.03	(128.0)	0	1.60	(40.6)
5.01	(127.5)	4	1.58	(40.1)
4.99	(126.5)	8	1.56	(39.6)
4.97	(126.0)	12	1.54	(39.1)
4.95	(125.5)	16	1.52	(38.6)
4.93	(125.0)	20	1.50	(38.1)
4.91	(124.5)	24	1.48	(37.6)
4.89	(124.0)	28	1.46	(37.1)
4.87	(123.5)	32	1.44	(36.6)
4.85	(123.0)	36	1.42	(36.1)
4.83	(122.5)	40	1.40	(35.6)
4.81	(122.0)	44	1.38	(35.1)
4.79	(121.5)	48	1.36	(34.5)
4.77	(121.0)	52	1.34	(34.0)
4.75	(120.5)	56	1.32	(33.5)
4.73	(120.0)	60	1.30	(33.0)
4.71	(119.5)	64	1.28	(32.5)
4.69	(119.0)	68	1.26	(32.0)
4.67	(118.5)	72	1.24	(31.5)
4.65	(118.0)	76	1.22	(31.0)
4.63	(117.5)	80	1.20	(30.5)
4.61	(117.0)	84	1.18	(30.0)
4.59	(116.5)	88	1.16	(29.5)
4.57	(116.0)	92	1.14	(29.0)
4.55	(115.5)	96	1.12	(28.4)
4.53	(115.0)	100	1.10	(27.9)
4.51	(114.5)	103	1.08	(27.4)
4.49	(114.0)	106	1.06	(26.9)
4.47	(113.5)	109	1.04	(26.4)
4.45	(113.0)	112	1.02	(25.9)
4.43	(112.5)	115	1.00	(25.4)
4.41	(112.0)	118	0.98	(24.9)
4.39	(111.5)	121	0.96	(24.4)

# D6, 955 - 8.00 in. (203.2 mm)

## Track Links <sup>(1)</sup> 7T-4645 & 46 Extended Life Links

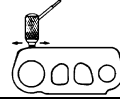
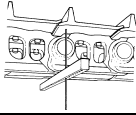

Depth Gauge			Ultrasonic	
Inches	(mm)	% Worn	Inches	(mm)
5.03	(128.0)	0	1.67	(42.4)
5.01	(127.5)	4	1.65	(41.9)
4.99	(126.5)	8	1.63	(41.4)
4.97	(126.0)	12	1.61	(40.9)
4.95	(125.5)	16	1.59	(40.4)
4.93	(125.0)	20	1.57	(39.9)
4.91	(124.5)	24	1.55	(39.4)
4.89	(124.0)	28	1.53	(38.9)
4.87	(123.5)	32	1.51	(38.4)
4.85	(123.0)	36	1.49	(37.8)
4.83	(122.5)	40	1.47	(37.3)
4.81	(122.0)	44	1.45	(36.8)
4.79	(121.5)	48	1.43	(36.3)
4.77	(121.0)	52	1.41	(35.8)
4.75	(120.5)	56	1.39	(35.3)
4.73	(120.0)	60	1.37	(34.8)
4.71	(119.5)	64	1.35	(34.3)
4.69	(119.0)	68	1.33	(33.8)
4.67	(118.5)	72	1.31	(33.3)
4.65	(118.0)	76	1.29	(32.8)
4.63	(117.5)	80	1.27	(32.3)
4.61	(117.0)	84	1.25	(31.8)
4.59	(116.5)	88	1.23	(31.2)
4.57	(116.0)	92	1.21	(30.7)
4.55	(115.5)	96	1.19	(30.2)
4.53	(115.0)	100	1.17	(29.7)
4.51	(114.5)	103	1.15	(29.2)
4.49	(114.0)	106	1.13	(28.7)
4.47	(113.5)	109	1.11	(28.2)
4.45	(113.0)	112	1.09	(27.7)
4.43	(112.5)	115	1.07	(27.2)
4.41	(112.0)	118	1.05	(26.7)
4.39	(111.5)	121	1.03	(26.2)



Track Links <sup>(1)</sup>  
3P-1112 & 13 Links

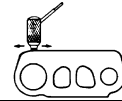
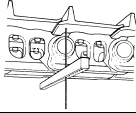

Depth Gauge			Ultrasonic	
Inches	(mm)	% Worn	Inches	(mm)
4.77	(121.0)	0	1.41	(35.8)
4.75	(120.5)	5	1.39	(35.3)
4.73	(120.0)	10	1.37	(34.8)
4.71	(119.5)	15	1.35	(34.3)
4.69	(119.0)	20	1.33	(33.8)
4.67	(118.5)	25	1.31	(33.3)
4.65	(118.0)	30	1.29	(32.8)
4.63	(117.5)	35	1.27	(32.3)
4.61	(117.0)	40	1.25	(31.8)
4.59	(116.5)	45	1.23	(31.2)
4.57	(116.0)	50	1.21	(30.7)
4.55	(115.5)	55	1.19	(30.2)
4.53	(115.0)	60	1.17	(29.7)
4.51	(114.5)	64	1.15	(29.2)
4.49	(114.0)	68	1.13	(28.7)
4.47	(113.5)	72	1.11	(28.2)
4.45	(113.0)	76	1.09	(27.7)
4.43	(112.5)	80	1.07	(27.2)
4.41	(112.0)	84	1.05	(26.7)
4.39	(111.5)	88	1.03	(26.2)
4.37	(111.0)	92	1.01	(25.7)
4.35	(110.5)	96	0.99	(25.1)
4.33	(110.0)	100	0.97	(24.6)
4.31	(109.5)	104	0.95	(24.1)
4.29	(109.0)	108	0.93	(23.6)
4.27	(108.5)	112	0.91	(23.1)
4.25	(108.0)	116	0.89	(22.6)
4.23	(107.5)	120	0.87	(22.1)

# D6, 955 - 8.00 in. (203.2 mm)

## Track Links <sup>(1)</sup> Classic 175-8256 & 57

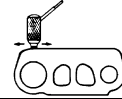
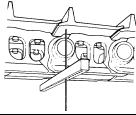

Depth Gauge			Ultrasonic	
Inches	(mm)	% Worn	Inches	(mm)
5.03	(128.0)	0	1.67	(42.4)
5.01	(127.5)	4	1.65	(41.9)
4.99	(126.5)	8	1.63	(41.4)
4.97	(126.0)	12	1.61	(40.9)
4.95	(125.5)	16	1.59	(40.4)
4.93	(125.0)	20	1.57	(39.9)
4.91	(124.5)	24	1.55	(39.4)
4.89	(124.0)	28	1.53	(38.9)
4.87	(123.5)	32	1.51	(38.4)
4.85	(123.0)	36	1.49	(37.8)
4.83	(122.5)	40	1.47	(37.3)
4.81	(122.0)	44	1.45	(36.8)
4.79	(121.5)	48	1.43	(36.3)
4.77	(121.0)	52	1.41	(35.8)
4.75	(120.5)	56	1.39	(35.3)
4.73	(120.0)	60	1.37	(34.8)
4.71	(119.5)	64	1.35	(34.3)
4.69	(119.0)	68	1.33	(33.8)
4.67	(118.5)	72	1.31	(33.3)
4.65	(118.0)	76	1.29	(32.8)
4.63	(117.5)	80	1.27	(32.3)
4.61	(117.0)	84	1.25	(31.8)
4.59	(116.5)	88	1.23	(31.2)
4.57	(116.0)	92	1.21	(30.7)
4.55	(115.5)	96	1.19	(30.2)
4.53	(115.0)	100	1.17	(29.7)
4.51	(114.5)	103	1.15	(29.2)
4.49	(114.0)	106	1.13	(28.7)
4.47	(113.5)	109	1.11	(28.2)
4.45	(113.0)	112	1.09	(27.7)
4.43	(112.5)	115	1.07	(27.2)
4.41	(112.0)	118	1.05	(26.7)
4.39	(111.5)	121	1.03	(26.2)

**Bushings <sup>(1)</sup>  
External Wear  
Sealed & Lubricated Track  
Heavy Duty Bushings  
Use with 8E Links**

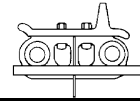
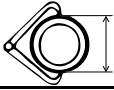

Caliper		Allowable Wear		Ultrasonic		Depth Gauge	
Inches	(mm)	Lesser % Worn	Greater % Worn	Inches	(mm)	Inches	(mm)
2.86	(72.6)	0	0	0.53	(13.5)	3.52	(89.4)
2.84	(72.1)	10	8	0.51	(13.0)	3.50	(88.9)
2.82	(71.6)	20	16	0.49	(12.4)	3.48	(88.4)
2.80	(71.1)	30	24	0.47	(11.9)	3.46	(87.9)
2.78	(70.6)	40	32	0.45	(11.4)	3.44	(87.4)
2.76	(70.1)	50	40	0.43	(10.9)	3.42	(86.9)
2.74	(69.6)	60	48	0.41	(10.4)	3.40	(86.4)
2.72	(69.1)	70	52	0.39	(9.9)	3.38	(85.9)
2.70	(68.6)	76	56	0.37	(9.4)	3.36	(85.3)
2.68	(68.1)	80	60	0.35	(8.9)	3.34	(84.8)
2.66	(67.6)	84	64	0.33	(8.4)	3.32	(84.3)
2.64	(67.1)	88	68	0.31	(7.9)	3.30	(83.8)
2.62	(66.5)	92	72	0.29	(7.4)	3.28	(83.3)
2.60	(66.0)	96	76	0.27	(6.9)	3.26	(82.8)
2.58	(65.5)	100	80	0.25	(6.3)	3.24	(82.3)
2.56	(65.0)	104	84	0.23	(5.8)	3.22	(81.8)
2.54	(64.5)	108	88	0.21	(5.3)	3.20	(81.3)
2.52	(64.0)	112	92	0.19	(4.8)	3.18	(80.8)
2.50	(63.5)	116	96	0.17	(4.3)	3.16	(80.3)
2.48	(63.0)	120	100	0.15	(3.8)	3.14	(79.8)
2.46	(62.5)		104	0.13	(3.3)	3.12	(79.2)
2.44	(62.0)		108	0.11	(2.8)	3.10	(78.7)
2.42	(61.5)		112	0.09	(2.3)	3.08	(78.2)
2.40	(61.0)		116	0.07	(1.8)	3.06	(77.7)
2.38	(60.5)		120	0.05	(1.3)	3.04	(77.2)

**D6, 955 - 8.00 in. (203.2 mm)**

**Bushings <sup>(1)</sup>  
External Wear  
Sealed & Lubricated Track  
Enhanced SALT Track**

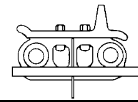
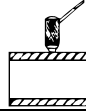

Caliper		Allowable Wear		Ultrasonic		Depth Gauge	
Inches	(mm)	Lesser % Worn	Greater % Worn	Inches	(mm)	Inches	(mm)
2.86	(72.6)	0	0	0.53	(13.5)	3.49	(88.6)
2.84	(72.1)	10	8	0.51	(13.0)	3.47	(88.1)
2.82	(71.6)	20	16	0.49	(12.4)	3.45	(87.6)
2.80	(71.1)	30	24	0.47	(11.9)	3.43	(87.1)
2.78	(70.6)	40	32	0.45	(11.4)	3.41	(86.6)
2.76	(70.1)	50	40	0.43	(10.9)	3.39	(86.1)
2.74	(69.6)	60	48	0.41	(10.4)	3.37	(85.6)
2.72	(69.1)	70	52	0.39	(9.9)	3.35	(85.1)
2.70	(68.6)	76	56	0.37	(9.4)	3.33	(84.6)
2.68	(68.1)	80	60	0.35	(8.9)	3.31	(84.1)
2.66	(67.6)	84	64	0.33	(8.4)	3.29	(83.6)
2.64	(67.1)	88	68	0.31	(7.9)	3.27	(83.1)
2.62	(66.5)	92	72	0.29	(7.4)	3.25	(82.6)
2.60	(66.0)	96	76	0.27	(6.9)	3.23	(82.0)
2.58	(65.5)	100	80	0.25	(6.3)	3.21	(81.5)
2.56	(65.0)	104	84	0.23	(5.8)	3.19	(81.0)
2.54	(64.5)	108	88	0.21	(5.3)	3.17	(80.5)
2.52	(64.0)	112	92	0.19	(4.8)	3.15	(80.0)
2.50	(63.5)	116	96	0.17	(4.3)	3.13	(79.5)
2.48	(63.0)	120	100	0.15	(3.8)	3.11	(79.0)
2.46	(62.5)		104	0.13	(3.3)	3.09	(78.5)
2.44	(62.0)		108	0.11	(2.8)	3.07	(78.0)
2.42	(61.5)		112	0.09	(2.3)	3.05	(77.5)
2.40	(61.0)		116	0.07	(1.8)	3.03	(77.0)
2.38	(60.5)		120	0.05	(1.3)	3.01	(76.5)

**Bushings <sup>(1)</sup>**  
**External Wear**  
**Sealed & Lubricated Track**  
 Use with Extended Life Track and earlier track with large diameter bushings

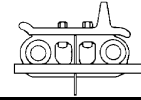
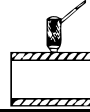

Caliper		Allowable Wear		Ultrasonic		Depth Gauge	
Inches	(mm)	Lesser % Worn	Greater % Worn	Inches	(mm)	Inches	(mm)
2.86	(72.6)	0	0	0.53	(13.5)	3.49	(88.6)
2.84	(72.1)	10	8	0.51	(13.0)	3.47	(88.1)
2.82	(71.6)	20	16	0.49	(12.4)	3.45	(87.6)
2.80	(71.1)	30	24	0.47	(11.9)	3.43	(87.1)
2.78	(70.6)	40	32	0.45	(11.4)	3.41	(86.6)
2.76	(70.1)	50	40	0.43	(10.9)	3.39	(86.1)
2.74	(69.6)	60	48	0.41	(10.4)	3.37	(85.6)
2.72	(69.1)	70	56	0.39	(9.9)	3.35	(85.1)
2.70	(68.6)	76	64	0.37	(9.4)	3.33	(84.6)
2.68	(68.1)	82	68	0.35	(8.9)	3.31	(84.1)
2.66	(67.6)	88	72	0.33	(8.4)	3.29	(83.6)
2.64	(67.1)	94	76	0.31	(7.9)	3.27	(83.1)
2.62	(66.5)	100	80	0.29	(7.4)	3.25	(82.6)
2.60	(66.0)	106	84	0.27	(6.9)	3.23	(82.0)
2.58	(65.5)	112	88	0.25	(6.3)	3.21	(81.5)
2.56	(65.0)	118	92	0.23	(5.8)	3.19	(81.0)
2.54	(64.5)	124	96	0.21	(5.3)	3.17	(80.5)
2.52	(64.0)		100	0.19	(4.8)	3.15	(80.0)
2.50	(63.5)		104	0.17	(4.3)	3.13	(79.5)
2.48	(63.0)		108	0.15	(3.8)	3.11	(79.0)
2.46	(62.5)		112	0.13	(3.3)	3.09	(78.5)
2.44	(62.0)		116	0.11	(2.8)	3.07	(78.0)
2.42	(61.5)		120	0.09	(2.3)	3.05	(77.5)

# D6, 955 - 8.00 in. (203.2 mm)

**Bushings <sup>(1)</sup>  
External Wear  
Rotating Bushing Track  
Use with 8E Links**

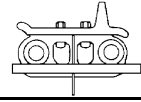
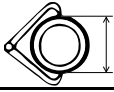

Caliper			Ultrasonic		Depth Gauge	
Inches	(mm)	% Worn	Inches	(mm)	Inches	(mm)
2.86	(72.6)	0	0.55	(14.0)	3.56	(90.4)
2.82	(71.6)	8	0.53	(13.5)	3.54	(89.9)
2.78	(70.6)	16	0.51	(13.0)	3.52	(89.4)
2.74	(69.6)	24	0.49	(12.4)	3.50	(88.9)
2.70	(68.6)	32	0.47	(11.9)	3.48	(88.4)
2.66	(67.6)	40	0.45	(11.4)	3.46	(87.9)
2.62	(66.5)	44	0.43	(10.9)	3.44	(87.4)
2.58	(65.5)	48	0.41	(10.4)	3.42	(86.9)
2.54	(64.5)	52	0.39	(9.9)	3.40	(86.4)
2.50	(63.5)	56	0.37	(9.4)	3.38	(85.9)
2.46	(62.5)	60	0.35	(8.9)	3.36	(85.3)
2.42	(61.5)	64	0.33	(8.4)	3.34	(84.8)
2.38	(60.5)	68	0.31	(7.9)	3.32	(84.3)
2.34	(59.4)	72	0.29	(7.4)	3.30	(83.8)
2.30	(58.4)	76	0.27	(6.9)	3.28	(83.3)
2.26	(57.4)	80	0.25	(6.3)	3.26	(82.8)
2.22	(56.4)	84	0.23	(5.8)	3.24	(82.3)
2.18	(55.4)	88	0.21	(5.3)	3.22	(81.8)
2.14	(54.4)	92	0.19	(4.8)	3.20	(81.3)
2.10	(53.3)	96	0.17	(4.3)	3.18	(80.8)
2.06	(52.3)	100	0.15	(3.8)	3.16	(80.3)
2.02	(51.3)	104	0.13	(3.3)	3.14	(79.8)
1.98	(50.3)	108	0.11	(2.8)	3.12	(79.2)
1.94	(49.3)	112	0.09	(2.3)	3.10	(78.7)
1.90	(48.3)	116	0.07	(1.8)	3.08	(78.2)
1.86	(47.2)	120	0.05	(1.3)	3.06	(77.7)

1 Wear Chart: 705/706

**Bushings (1)  
External Wear  
Sealed & Lubricated Track  
Use with earlier track with small diameter bushings**

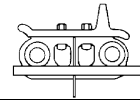
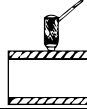

Caliper		Allowable Wear		Ultrasonic		Depth Gauge	
		Lesser % Worn	Greater % Worn	Inches	(mm)	Inches	(mm)
Inches	(mm)						
2.74	(69.6)	0	0	0.47	(11.9)	3.43	(87.1)
2.73	(69.3)	6	5	0.46	(11.7)	3.42	(86.9)
2.72	(69.1)	12	10	0.45	(11.4)	3.41	(86.6)
2.71	(68.8)	18	15	0.44	(11.2)	3.40	(86.4)
2.70	(68.6)	24	20	0.43	(10.9)	3.39	(86.1)
2.69	(68.3)	30	25	0.42	(10.7)	3.38	(85.9)
2.68	(68.1)	36	30	0.41	(10.4)	3.37	(85.6)
2.67	(67.8)	42	35	0.40	(10.2)	3.36	(85.3)
2.66	(67.6)	48	40	0.39	(9.9)	3.35	(85.1)
2.65	(67.3)	54	45	0.38	(9.7)	3.34	(84.8)
2.64	(67.1)	60	50	0.37	(9.4)	3.33	(84.6)
2.63	(66.8)	66	55	0.36	(9.1)	3.32	(84.3)
2.62	(66.5)	72	60	0.35	(8.9)	3.31	(84.1)
2.61	(66.3)	78	65	0.34	(8.6)	3.30	(83.8)
2.60	(66.0)	84	70	0.33	(8.4)	3.29	(83.6)
2.59	(65.8)	88	72	0.32	(8.1)	3.28	(83.3)
2.58	(65.5)	91	74	0.31	(7.9)	3.27	(83.1)
2.57	(65.3)	94	76	0.30	(7.6)	3.26	(82.8)
2.56	(65.0)	97	78	0.29	(7.4)	3.25	(82.6)
2.55	(64.8)	100	80	0.28	(7.1)	3.24	(82.3)
2.54	(64.5)	103	82	0.27	(6.9)	3.23	(82.0)
2.53	(64.3)	106	84	0.26	(6.6)	3.22	(81.8)
2.52	(64.0)	109	86	0.25	(6.3)	3.21	(81.5)
2.51	(63.8)	112	88	0.24	(6.1)	3.20	(81.3)
2.50	(63.5)	115	90	0.23	(5.8)	3.19	(81.0)
2.49	(63.2)	118	92	0.22	(5.6)	3.18	(80.8)
2.48	(63.0)	121	94	0.21	(5.3)	3.17	(80.5)
2.47	(62.7)		96	0.20	(5.1)	3.16	(80.3)
2.46	(62.5)		98	0.19	(4.8)	3.15	(80.0)
2.45	(62.2)		100	0.18	(4.6)	3.14	(79.8)
2.44	(62.0)		102	0.17	(4.3)	3.13	(79.5)
2.43	(61.7)		104	0.16	(4.1)	3.12	(79.2)
2.42	(61.5)		106	0.15	(3.8)	3.11	(79.0)
2.41	(61.2)		108	0.14	(3.6)	3.10	(78.7)
2.40	(61.0)		110	0.13	(3.3)	3.09	(78.5)
2.39	(60.7)		112	0.12	(3.0)	3.08	(78.2)
2.38	(60.5)		114	0.11	(2.8)	3.07	(78.0)
2.37	(60.2)		116	0.10	(2.5)	3.06	(77.7)
2.36	(59.9)		118	0.09	(2.3)	3.05	(77.5)
2.35	(59.7)		120	0.08	(2.0)	3.04	(77.2)

# D6, 955 - 8.00 in. (203.2 mm)

## Bushings <sup>(1)</sup> Classic External Wear Sealed & Lubricated Track

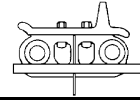
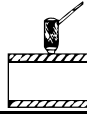

Caliper		Allowable Wear		Ultrasonic		Depth Gauge	
Inches	(mm)	Lesser % Worn	Greater % Worn	Inches	(mm)	Inches	(mm)
2.74	(69.6)	0	0	0.47	(11.9)	3.43	(87.1)
2.73	(69.3)	6	5	0.46	(11.7)	3.42	(86.9)
2.72	(69.1)	12	10	0.45	(11.4)	3.41	(86.6)
2.71	(68.8)	18	15	0.44	(11.2)	3.40	(86.4)
2.70	(68.6)	24	20	0.43	(10.9)	3.39	(86.1)
2.69	(68.3)	30	25	0.42	(10.7)	3.38	(85.9)
2.68	(68.1)	36	30	0.41	(10.4)	3.37	(85.6)
2.67	(67.8)	42	35	0.40	(10.2)	3.36	(85.3)
2.66	(67.6)	48	40	0.39	(9.9)	3.35	(85.1)
2.65	(67.3)	54	45	0.38	(9.7)	3.34	(84.8)
2.64	(67.1)	60	50	0.37	(9.4)	3.33	(84.6)
2.63	(66.8)	66	55	0.36	(9.1)	3.32	(84.3)
2.62	(66.5)	72	60	0.35	(8.9)	3.31	(84.1)
2.61	(66.3)	78	65	0.34	(8.6)	3.30	(83.8)
2.60	(66.0)	84	70	0.33	(8.4)	3.29	(83.6)
2.59	(65.8)	88	72	0.32	(8.1)	3.28	(83.3)
2.58	(65.5)	91	74	0.31	(7.9)	3.27	(83.1)
2.57	(65.3)	94	76	0.30	(7.6)	3.26	(82.8)
2.56	(65.0)	97	78	0.29	(7.4)	3.25	(82.6)
2.55	(64.8)	100	80	0.28	(7.1)	3.24	(82.3)
2.54	(64.5)	103	82	0.27	(6.9)	3.23	(82.0)
2.53	(64.3)	106	84	0.26	(6.6)	3.22	(81.8)
2.52	(64.0)	109	86	0.25	(6.3)	3.21	(81.5)
2.51	(63.8)	112	88	0.24	(6.1)	3.20	(81.3)
2.50	(63.5)	115	90	0.23	(5.8)	3.19	(81.0)
2.49	(63.2)	118	92	0.22	(5.6)	3.18	(80.8)
2.48	(63.0)	121	94	0.21	(5.3)	3.17	(80.5)
2.47	(62.7)		96	0.20	(5.1)	3.16	(80.3)
2.46	(62.5)		98	0.19	(4.8)	3.15	(80.0)
2.45	(62.2)		100	0.18	(4.6)	3.14	(79.8)
2.44	(62.0)		102	0.17	(4.3)	3.13	(79.5)
2.43	(61.7)		104	0.16	(4.1)	3.12	(79.2)
2.42	(61.5)		106	0.15	(3.8)	3.11	(79.0)
2.41	(61.2)		108	0.14	(3.6)	3.10	(78.7)
2.40	(61.0)		110	0.13	(3.3)	3.09	(78.5)
2.39	(60.7)		112	0.12	(3.0)	3.08	(78.2)
2.38	(60.5)		114	0.11	(2.8)	3.07	(78.0)
2.37	(60.2)		116	0.10	(2.5)	3.06	(77.7)
2.36	(59.9)		118	0.09	(2.3)	3.05	(77.5)
2.35	(59.7)		120	0.08	(2.0)	3.04	(77.2)



**Pins and Bushings <sup>(1)</sup>  
Genuine and Classic  
Internal Wear  
Sealed Track**

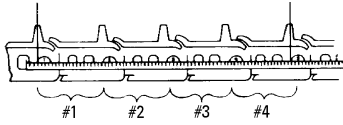

Inches	(mm)	% Worn
32.00	(813.0)	0
32.05	(814.0)	10
32.10	(815.5)	20
32.15	(816.5)	30
32.20	(818.0)	40
32.25	(819.0)	50
32.30	(820.5)	60
32.35	(821.5)	70
32.40	(823.0)	80
32.45	(824.0)	90
32.50	(825.5)	100
32.55	(827.0)	105
32.60	(828.0)	110
32.65	(829.5)	115
32.70	(830.5)	120

# D6, 955 - 8.00 in. (203.2 mm)

**Bushings <sup>(1)</sup>**  
**External Wear**  
**Sealed Track**  
**Enhanced SALT Track**

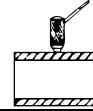

Caliper		Allowable Wear		Ultrasonic	
		Lesser	Greater		
Inches	(mm)	% Worn	% Worn	Inches	(mm)
2.86	(72.6)	0	0	0.53	(13.5)
2.84	(72.1)	10	8	0.51	(13.0)
2.82	(71.6)	20	16	0.49	(12.4)
2.80	(71.1)	30	24	0.47	(11.9)
2.78	(70.6)	40	32	0.45	(11.4)
2.76	(70.1)	50	40	0.43	(10.9)
2.74	(69.6)	60	48	0.41	(10.4)
2.72	(69.1)	70	56	0.39	(9.9)
2.70	(68.6)	80	64	0.37	(9.4)
2.68	(68.1)	88	72	0.35	(8.9)
2.66	(67.6)	92	80	0.33	(8.4)
2.64	(67.1)	96	84	0.31	(7.9)
2.62	(66.5)	100	88	0.29	(7.4)
2.60	(66.0)	104	92	0.27	(6.9)
2.58	(65.5)	108	96	0.25	(6.3)
2.56	(65.0)	112	100	0.23	(5.8)
2.54	(64.5)	116	104	0.21	(5.3)
2.52	(64.0)	120	108	0.19	(4.8)
2.50	(63.5)		112	0.17	(4.3)
2.48	(63.0)		116	0.15	(3.8)
2.46	(62.5)		120	0.13	(3.3)

1 Wear Chart: 1005

**Bushings <sup>(1)</sup>  
External Wear  
Sealed Track**

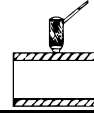

Caliper		Allowable Wear		Ultrasonic	
Inches	(mm)	Lesser % Worn	Greater % Worn	Inches	(mm)
2.64	(67.1)	0	0	0.42	(10.7)
2.63	(66.8)	9	7	0.41	(10.4)
2.62	(66.5)	18	14	0.40	(10.2)
2.61	(66.3)	27	21	0.39	(9.9)
2.60	(66.0)	36	28	0.38	(9.7)
2.59	(65.8)	45	35	0.37	(9.4)
2.58	(65.5)	54	42	0.36	(9.1)
2.57	(65.3)	63	49	0.35	(8.9)
2.56	(65.0)	72	56	0.34	(8.6)
2.55	(64.8)	81	63	0.33	(8.4)
2.54	(64.5)	88	70	0.32	(8.1)
2.53	(64.3)	92	73	0.31	(7.9)
2.52	(64.0)	96	76	0.30	(7.6)
2.51	(63.8)	100	79	0.29	(7.4)
2.50	(63.5)	104	82	0.28	(7.1)
2.49	(63.2)	108	85	0.27	(6.9)
2.48	(63.0)	112	88	0.26	(6.6)
2.47	(62.7)	116	91	0.25	(6.4)
2.46	(62.5)	120	94	0.24	(6.1)
2.45	(62.2)		97	0.23	(5.8)
2.44	(62.0)		100	0.22	(5.6)
2.43	(61.7)		103	0.21	(5.3)
2.42	(61.5)		106	0.20	(5.1)
2.41	(61.2)		109	0.19	(4.8)
2.40	(61.0)		112	0.18	(4.6)
2.39	(60.7)		115	0.17	(4.3)
2.38	(60.5)		118	0.16	(4.1)
2.37	(60.2)		121	0.15	(3.8)

# D6, 955 - 8.00 in. (203.2 mm)

## Bushings <sup>(1)</sup> Classic External Wear Sealed Track

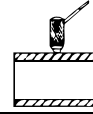

Caliper		Allowable Wear		Ultrasonic	
Inches	(mm)	Lesser % Worn	Greater % Worn	Inches	(mm)
2.62	(66.5)	0	0	0.41	(10.4)
2.61	(66.3)	9	7	0.40	(10.2)
2.60	(66.0)	18	14	0.39	(9.9)
2.59	(65.8)	27	21	0.38	(9.7)
2.58	(65.5)	36	28	0.37	(9.4)
2.57	(65.3)	45	35	0.36	(9.1)
2.56	(65.0)	54	42	0.35	(8.9)
2.55	(64.8)	63	49	0.34	(8.6)
2.54	(64.5)	72	56	0.33	(8.4)
2.53	(64.3)	81	63	0.32	(8.1)
2.52	(64.0)	90	70	0.31	(7.9)
2.51	(63.8)	96	76	0.30	(7.6)
2.50	(63.5)	100	79	0.29	(7.4)
2.49	(63.2)	104	82	0.28	(7.1)
2.48	(63.0)	108	85	0.27	(6.9)
2.47	(62.7)	112	88	0.26	(6.6)
2.46	(62.5)	116	91	0.25	(6.4)
2.45	(62.2)	120	94	0.24	(6.1)
2.44	(62.0)		97	0.23	(5.8)
2.43	(61.7)		100	0.22	(5.6)
2.42	(61.5)		103	0.21	(5.3)
2.41	(61.2)		106	0.20	(5.1)
2.40	(61.0)		109	0.19	(4.8)
2.39	(60.7)		112	0.18	(4.6)
2.38	(60.5)		115	0.17	(4.3)
2.37	(60.2)		118	0.16	(4.1)
2.36	(59.9)		121	0.15	(3.8)

**Track Shoes <sup>(1)</sup>  
Extreme Service**

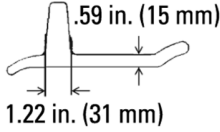
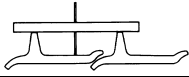

Depth Gauge		High Impact	Low Impact	Ultrasonic	
Inches	(mm)	% Worn	% Worn	Inches	(mm)
2.95	(75.0)	0	0	3.55	(90.2)
2.85	(72.5)	8	6	3.45	(87.6)
2.75	(70.0)	16	12	3.35	(85.1)
2.65	(67.5)	24	18	3.25	(82.6)
2.55	(65.0)	32	24	3.15	(80.0)
2.45	(62.0)	40	30	3.05	(77.5)
2.35	(59.5)	48	36	2.95	(74.9)
2.30	(58.5)	52	39	2.90	(73.7)
2.20	(56.0)	58	45	2.80	(71.1)
2.10	(53.5)	64	51	2.70	(68.6)
2.00	(51.0)	70	57	2.60	(66.0)
1.90	(48.5)	76	63	2.50	(63.5)
1.80	(45.5)	82	68	2.40	(61.0)
1.70	(43.0)	88	72	2.30	(58.4)
1.60	(40.5)	94	76	2.20	(55.9)
1.50	(38.0)	100	80	2.10	(53.3)
1.40	(35.5)	106	84	2.00	(50.8)
1.30	(33.0)	112	88	1.90	(48.3)
1.20	(30.5)	118	92	1.80	(45.7)
1.10	(28.0)	124	96	1.70	(43.2)
1.00	(25.5)		100	1.60	(40.6)
0.90	(23.0)		104	1.50	(38.1)
0.80	(20.5)		108	1.40	(35.6)
0.70	(18.0)		112	1.30	(33.0)
0.60	(15.0)		116	1.20	(30.5)
0.50	(12.5)		120	1.10	(27.9)

# D6, 955 - 8.00 in. (203.2 mm)

## Track Shoes <sup>(1)</sup> Classic Extreme Service

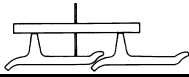

Depth Gauge		High Impact	Low Impact	Ultrasonic	
Inches	(mm)	% Worn	% Worn	Inches	(mm)
2.80	(71.0)	0	0	3.35	(85.1)
2.70	(68.5)	8	6	3.25	(82.6)
2.60	(66.0)	16	12	3.15	(80.0)
2.50	(63.5)	24	18	3.05	(77.5)
2.40	(61.0)	32	24	2.95	(74.9)
2.30	(58.5)	40	30	2.85	(72.4)
2.20	(56.0)	48	36	2.75	(69.9)
2.10	(53.5)	56	42	2.65	(67.3)
2.00	(51.0)	64	48	2.55	(64.8)
1.90	(48.5)	72	54	2.45	(62.2)
1.80	(45.5)	79	60	2.35	(59.7)
1.70	(43.0)	86	65	2.25	(57.2)
1.60	(40.5)	93	70	2.15	(54.6)
1.50	(38.0)	100	75	2.05	(52.1)
1.40	(35.5)	107	80	1.95	(49.5)
1.30	(33.0)	114	85	1.85	(47.0)
1.20	(30.5)	121	90	1.75	(44.5)
1.10	(28.0)		95	1.65	(41.9)
1.00	(25.5)		100	1.55	(39.4)
0.90	(23.0)		105	1.45	(36.8)
0.80	(20.5)		110	1.35	(34.3)
0.70	(18.0)		115	1.25	(31.8)
0.60	(15.0)		120	1.15	(29.2)

**Track Shoes <sup>(1)</sup>  
Moderate Service**

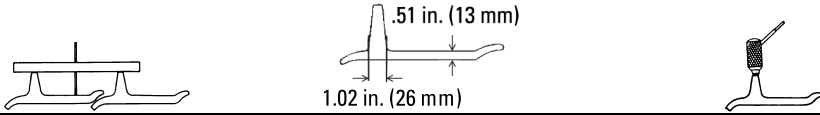

Depth Gauge		High Impact	Low/Moderate	Ultrasonic	
Inches	(mm)	% Worn	Impact % Worn	Inches	(mm)
2.55	(65.0)	0	0	3.05	(77.5)
2.50	(63.5)	5	4	3.00	(76.2)
2.45	(62.0)	10	8	2.95	(74.9)
2.40	(61.0)	15	12	2.90	(73.7)
2.35	(59.5)	20	16	2.85	(72.4)
2.30	(58.5)	25	20	2.80	(71.1)
2.25	(57.0)	30	24	2.75	(69.9)
2.20	(56.0)	35	28	2.70	(68.6)
2.15	(54.5)	40	31	2.65	(67.3)
2.10	(53.5)	45	34	2.60	(66.0)
2.05	(52.0)	50	37	2.55	(64.8)
2.00	(51.0)	55	40	2.50	(63.5)
1.95	(49.5)	60	43	2.45	(62.2)
1.90	(48.5)	65	46	2.40	(61.0)
1.85	(47.0)	70	49	2.35	(59.7)
1.80	(45.5)	75	52	2.30	(58.4)
1.75	(44.5)	80	55	2.25	(57.2)
1.70	(43.0)	84	58	2.20	(55.9)
1.65	(42.0)	88	61	2.15	(54.6)
1.60	(40.5)	92	64	2.10	(53.3)
1.55	(39.5)	96	67	2.05	(52.1)
1.50	(38.0)	100	70	2.00	(50.8)
1.45	(37.0)	104	73	1.95	(49.5)
1.40	(35.5)	108	76	1.90	(48.3)
1.35	(34.5)	112	79	1.85	(47.0)
1.30	(33.0)	116	82	1.80	(45.7)
1.25	(32.0)	120	85	1.75	(44.5)
1.20	(30.5)		88	1.70	(43.2)
1.15	(29.0)		91	1.65	(41.9)
1.10	(28.0)		94	1.60	(40.6)
1.05	(26.5)		97	1.55	(39.4)
1.00	(25.5)		100	1.50	(38.1)
0.95	(24.0)		103	1.45	(36.8)
0.90	(23.0)		106	1.40	(35.6)
0.85	(21.5)		109	1.35	(34.3)
0.80	(20.5)		112	1.30	(33.0)
0.75	(19.0)		115	1.25	(31.8)
0.70	(18.0)		118	1.20	(30.5)
0.65	(16.5)		121	1.15	(29.2)

# D6, 955 - 8.00 in. (203.2 mm)

## Track Shoes <sup>(1)</sup> Classic Moderate Service

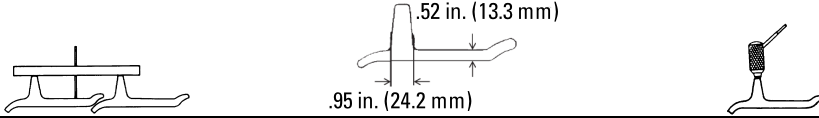

Depth Gauge		High Impact	Low/Moderate	Ultrasonic	
Inches	(mm)	% Worn	Impact % Worn	Inches	(mm)
2.25	(57.0)	0	0	2.80	(71.1)
2.20	(56.0)	7	4	2.75	(69.9)
2.15	(54.5)	14	8	2.70	(68.6)
2.10	(53.5)	21	12	2.65	(67.3)
2.05	(52.0)	28	16	2.60	(66.0)
2.00	(51.0)	35	20	2.55	(64.8)
1.95	(49.5)	42	24	2.50	(63.5)
1.90	(48.5)	49	28	2.45	(62.2)
1.85	(47.0)	56	32	2.40	(61.0)
1.80	(45.5)	63	36	2.35	(59.7)
1.75	(44.5)	70	40	2.30	(58.4)
1.70	(43.0)	76	44	2.25	(57.2)
1.65	(42.0)	82	48	2.20	(55.9)
1.60	(40.5)	88	52	2.15	(54.6)
1.55	(39.5)	94	56	2.10	(53.3)
1.50	(38.0)	100	60	2.05	(52.1)
1.45	(37.0)	106	64	2.00	(50.8)
1.40	(35.5)	112	68	1.95	(49.5)
1.35	(34.5)	118	72	1.90	(48.3)
1.30	(33.0)	124	76	1.85	(47.0)
1.25	(32.0)		80	1.80	(45.7)
1.20	(30.5)		84	1.75	(44.5)
1.15	(29.0)		88	1.70	(43.2)
1.10	(28.0)		92	1.65	(41.9)
1.05	(26.5)		96	1.60	(40.6)
1.00	(25.5)		100	1.55	(39.4)
0.95	(24.0)		103	1.50	(38.1)
0.90	(23.0)		106	1.45	(36.8)
0.85	(21.5)		109	1.40	(35.6)
0.80	(20.5)		112	1.35	(34.3)
0.75	(19.0)		115	1.30	(33.0)
0.70	(18.0)		118	1.25	(31.8)
0.65	(16.5)		121	1.20	(30.5)



**Track Shoes <sup>(1)</sup>  
Double Grouser**

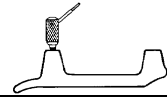
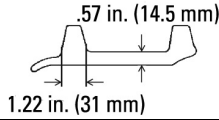
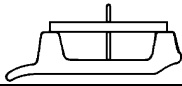

Depth Gauge		High Impact	Low/Moderate	Ultrasonic	
Inches	(mm)	% Worn	Impact % Worn	Inches	(mm)
1.65	(42.0)	0	0	2.20	(55.9)
1.60	(40.5)	6	5	2.15	(54.6)
1.55	(39.5)	12	10	2.10	(53.3)
1.50	(38.0)	18	15	2.05	(52.1)
1.45	(37.0)	24	20	2.00	(50.8)
1.40	(35.5)	30	25	1.95	(49.5)
1.35	(34.5)	36	30	1.90	(48.3)
1.30	(33.0)	42	35	1.85	(47.0)
1.25	(32.0)	48	40	1.80	(45.7)
1.20	(30.5)	54	44	1.75	(44.5)
1.15	(29.0)	60	48	1.70	(43.2)
1.10	(28.0)	65	52	1.65	(41.9)
1.05	(26.5)	70	56	1.60	(40.6)
1.00	(25.5)	75	60	1.55	(39.4)
0.95	(24.0)	80	64	1.50	(38.1)
0.90	(23.0)	85	68	1.45	(36.8)
0.85	(21.5)	90	72	1.40	(35.6)
0.80	(20.5)	95	76	1.35	(34.3)
0.75	(19.0)	100	80	1.30	(33.0)
0.70	(18.0)	105	84	1.25	(31.8)
0.65	(16.5)	110	88	1.20	(30.5)
0.60	(15.0)	115	92	1.15	(29.2)
0.55	(14.0)	120	96	1.10	(27.9)
0.50	(12.5)		100	1.05	(26.7)
0.45	(11.5)		104	1.00	(25.4)
0.40	(10.0)		108	0.95	(24.1)
0.35	(9.0)		112	0.90	(22.9)
0.30	(7.5)		116	0.85	(21.6)
0.25	(6.5)		120	0.80	(20.3)

# D6, 955 - 8.00 in. (203.2 mm)

## Track Shoes <sup>(1)</sup> Classic Double Grouser

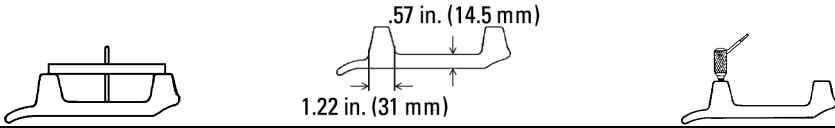

Depth Gauge		High Impact	Low/Moderate	Ultrasonic	
Inches	(mm)	% Worn	Impact % Worn	Inches	(mm)
1.35	(34.5)	0	0	1.90	(48.3)
1.30	(33.0)	9	6	1.85	(47.0)
1.25	(32.0)	18	12	1.80	(45.7)
1.20	(30.5)	27	18	1.75	(44.5)
1.15	(29.0)	36	24	1.70	(43.2)
1.10	(28.0)	44	30	1.65	(41.9)
1.05	(26.5)	52	36	1.60	(40.6)
1.00	(25.5)	60	42	1.55	(39.4)
0.95	(24.0)	68	48	1.50	(38.1)
0.90	(23.0)	76	54	1.45	(36.8)
0.85	(21.5)	84	60	1.40	(35.6)
0.80	(20.5)	92	66	1.35	(34.3)
0.75	(19.0)	100	72	1.30	(33.0)
0.70	(18.0)	108	78	1.25	(31.8)
0.65	(16.5)	116	84	1.20	(30.5)
0.60	(15.0)	124	90	1.15	(29.2)
0.55	(14.0)		95	1.10	(27.9)
0.50	(12.5)		100	1.05	(26.7)
0.45	(11.5)		105	1.00	(25.4)
0.40	(10.0)		110	0.95	(24.1)
0.35	(9.0)		115	0.90	(22.9)
0.30	(7.5)		120	0.85	(21.6)

**Track Shoes <sup>(1)</sup>  
Triple Grouser**

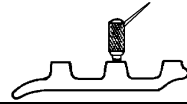
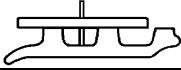
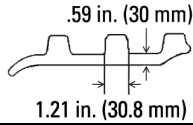

**Depth Gauge**

**Ultrasonic**

Depth Gauge		% Worn	Ultrasonic	
Inches	(mm)		Inches	(mm)
1.05	(26.5)	0	1.65	(41.9)
1.00	(25.5)	10	1.60	(40.6)
0.95	(24.0)	19	1.55	(39.4)
0.90	(23.0)	28	1.50	(38.1)
0.85	(21.5)	37	1.45	(36.8)
0.80	(20.5)	46	1.40	(35.6)
0.75	(19.0)	55	1.35	(34.3)
0.70	(18.0)	64	1.30	(33.0)
0.65	(16.5)	73	1.25	(31.8)
0.60	(15.0)	82	1.20	(30.5)
0.55	(14.0)	91	1.15	(29.2)
0.50	(12.5)	100	1.10	(27.9)
0.45	(11.5)	109	1.05	(26.7)
0.40	(10.0)	118	1.00	(25.4)
0.35	(9.0)	127	0.95	(24.1)

# D6, 955 - 8.00 in. (203.2 mm)

## Track Shoes <sup>(1)</sup> Self Cleaning



Depth Gauge

Inches	(mm)	% Worn
3.61	(91.5)	0
3.59	(91.0)	4
3.57	(90.5)	8
3.55	(90.0)	12
3.53	(89.5)	16
3.51	(89.0)	20
3.49	(88.5)	24
3.47	(88.0)	28
3.45	(87.5)	32
3.43	(87.0)	36
3.41	(86.5)	40
3.39	(86.0)	44
3.37	(85.5)	48
3.35	(85.0)	52
3.33	(84.5)	55
3.31	(84.0)	58
3.29	(83.5)	61
3.27	(83.0)	64
3.25	(82.5)	67
3.23	(82.0)	70
3.21	(81.5)	73
3.19	(81.0)	76
3.17	(80.5)	79
3.15	(80.0)	82
3.13	(79.5)	85
3.11	(79.0)	88
3.09	(78.5)	91
3.07	(78.0)	94
3.05	(77.5)	97
3.03	(77.0)	100
3.01	(76.5)	103
2.99	(76.0)	106
2.97	(75.5)	109
2.95	(75.0)	112
2.93	(74.5)	115
2.91	(74.0)	118
2.89	(73.5)	121

**Idlers** <sup>(1) (2) (3)</sup>  
**Extended Life Idlers**  
 (Has circular side plate indentations)

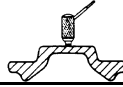
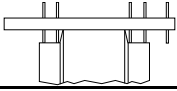

Depth Gauge		
Inches	(mm)	% Worn
0.78	(20.0)	0
0.80	(20.5)	6
0.82	(21.0)	12
0.84	(21.5)	18
0.86	(22.0)	24
0.88	(22.5)	30
0.90	(23.0)	36
0.92	(23.5)	42
0.94	(24.0)	48
0.96	(24.5)	54
0.98	(25.0)	60
1.00	(25.5)	66
1.02	(26.0)	72
1.04	(26.5)	76
1.06	(27.0)	78
1.08	(27.5)	80
1.10	(28.0)	82
1.12	(28.5)	84
1.14	(29.0)	86
1.16	(29.5)	88
1.18	(30.0)	90
1.20	(30.5)	92
1.22	(31.0)	94
1.24	(31.5)	96
1.26	(32.0)	98
1.28	(32.5)	100
1.30	(33.0)	102
1.32	(33.5)	104
1.34	(34.0)	106
1.36	(34.5)	108
1.38	(35.0)	110
1.40	(35.5)	112
1.42	(36.0)	114
1.44	(36.5)	116
1.46	(37.0)	118
1.48	(37.5)	120

Ultrasonic		Center Flange Wear	
Inches	(mm)	Inches	(mm)
0.49	(12.4)	0.00	(0.0)
0.47	(11.9)	0.02	(0.5)
0.45	(11.4)	0.04	(1.0)
0.43	(10.9)	0.06	(1.5)
0.41	(10.4)	0.08	(2.0)
0.39	(9.9)	0.10	(2.5)
0.37	(9.4)	0.12	(3.0)
0.35	(8.9)	0.14	(3.5)
0.33	(8.4)	0.16	(4.0)
0.31	(7.9)	0.18	(4.5)
0.29	(7.4)	0.20	(5.0)
0.27	(6.9)	0.22	(5.5)
0.25	(6.3)	0.24	(6.0)
0.23	(5.8)	0.26	(6.5)
0.21	(5.3)	0.28	(7.0)
0.19	(4.8)	0.30	(7.5)
0.17	(4.3)	0.32	(8.0)
0.15	(3.8)	0.34	(8.5)
0.13	(3.3)	0.36	(9.0)
0.11	(2.8)	0.38	(9.5)
0.09	(2.3)	0.40	(10.0)
0.07	(1.8)	0.42	(10.5)
0.05	(1.3)	0.44	(11.0)
0.03	(0.8)	0.46	(11.5)
0.01	(0.3)	0.48	(12.0)

**NOTE**

Ultrasonic measurement is to determine flange wear only.

- 1 Flange width is 3.74 in. (95 mm)
- 2 New tread diameter is 26.61 in. (676 mm)
- 3 Wear Chart: 4402

# D6, 955 - 8.00 in. (203.2 mm)

**Idlers <sup>(1)</sup> <sup>(2)</sup> <sup>(3)</sup>**  
**Genuine and Classic**  
**(Has no side plate indentations)**

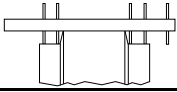

**Depth Gauge**

Inches	(mm)	% Worn
0.88	(22.5)	0
0.90	(23.0)	12
0.92	(23.5)	24
0.94	(24.0)	36
0.96	(24.5)	48
0.98	(25.0)	60
1.00	(25.5)	72
1.02	(26.0)	82
1.04	(26.5)	85
1.06	(27.0)	88
1.08	(27.5)	91
1.10	(28.0)	94
1.12	(28.5)	97
1.14	(29.0)	100
1.16	(29.5)	103
1.18	(30.0)	106
1.20	(30.5)	109
1.22	(31.0)	112
1.24	(31.5)	115
1.26	(32.0)	118
1.28	(32.5)	121

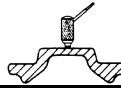

**Ultrasonic**

**Center Flange Wear**

Inches	(mm)	Inches	(mm)
0.42	(10.7)	0.00	(0.0)
0.40	(10.2)	0.02	(0.5)
0.38	(9.7)	0.04	(1.0)
0.36	(9.1)	0.06	(1.5)
0.34	(8.6)	0.08	(2.0)
0.32	(8.1)	0.10	(2.5)
0.30	(7.6)	0.12	(3.0)
0.28	(7.1)	0.14	(3.5)
0.26	(6.6)	0.16	(4.0)
0.24	(6.1)	0.18	(4.5)
0.22	(5.6)	0.20	(5.0)
0.20	(5.1)	0.22	(5.5)
0.18	(4.6)	0.24	(6.0)
0.16	(4.1)	0.26	(6.5)
0.14	(3.6)	0.28	(7.0)
0.12	(3.0)	0.30	(7.5)
0.10	(2.5)	0.32	(8.0)
0.08	(2.0)	0.34	(8.5)
0.06	(1.5)	0.36	(9.0)
0.04	(1.0)	0.38	(9.5)
0.02	(0.5)	0.40	(10.0)

**NOTE**

Ultrasonic measurement is to determine flange wear only.

- 1 Flange width is 3.75 in. (95.5 mm)
- 2 New tread diameter is 26.62 in. (676.2 mm)
- 3 Wear Chart: 4401

**Carrier Rollers <sup>(1)</sup>  
Genuine and Classic  
Use with 8E, 7T, and 228-2735 & 36 Links  
Not for use with 955**

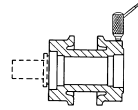
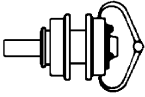

Caliper			Ultrasonic	
Inches	(mm)	% Worn	Inches	(mm)
7.38	(187.5)	0	1.86	(47.2)
7.30	(185.5)	8	1.82	(46.2)
7.22	(183.5)	16	1.78	(45.2)
7.14	(181.5)	24	1.74	(44.2)
7.06	(179.5)	32	1.70	(43.2)
6.98	(177.5)	40	1.66	(42.2)
6.90	(175.5)	48	1.62	(41.1)
6.82	(173.0)	56	1.58	(40.1)
6.74	(171.0)	64	1.54	(39.1)
6.66	(169.0)	68	1.50	(38.1)
6.58	(167.0)	72	1.46	(37.1)
6.50	(165.0)	76	1.42	(36.1)
6.42	(163.0)	80	1.38	(35.1)
6.34	(161.0)	84	1.34	(34.0)
6.26	(159.0)	88	1.30	(33.0)
6.18	(157.0)	92	1.26	(32.0)
6.10	(155.0)	96	1.22	(31.0)
6.02	(153.0)	100	1.18	(30.0)
5.94	(151.0)	104	1.14	(29.0)
5.86	(149.0)	108	1.10	(27.9)
5.78	(147.0)	112	1.06	(26.9)
5.70	(145.0)	116	1.02	(25.9)
5.62	142.5	120	0.98	(24.9)

# D6, 955 - 8.00 in. (203.2 mm)

**Carrier Rollers <sup>(1)</sup>**  
**Use with 3P Links**  
**Not for use with 955**

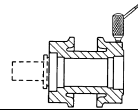
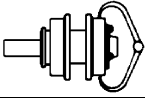

Caliper			Ultrasonic	
Inches	(mm)	% Worn	Inches	(mm)
7.38	(187.5)	0	1.86	(47.2)
7.34	(186.5)	5	1.84	(46.7)
7.30	(185.5)	10	1.82	(46.2)
7.26	(184.5)	15	1.80	(45.7)
7.22	(183.5)	20	1.78	(45.2)
7.18	(182.5)	25	1.76	(44.7)
7.14	(181.5)	30	1.74	(44.2)
7.10	(180.5)	35	1.72	(43.7)
7.06	(179.5)	40	1.70	(43.2)
7.02	(178.5)	45	1.68	(42.7)
6.98	(177.5)	50	1.66	(42.2)
6.94	(176.5)	55	1.64	(41.7)
6.90	(175.5)	60	1.62	(41.1)
6.86	(174.0)	65	1.60	(40.6)
6.82	(173.0)	70	1.58	(40.1)
6.78	(172.0)	75	1.56	(39.6)
6.74	(171.0)	79	1.54	(39.1)
6.70	(170.0)	82	1.52	(38.6)
6.66	(169.0)	85	1.50	(38.1)
6.62	(168.0)	88	1.48	(37.6)
6.58	(167.0)	91	1.46	(37.1)
6.54	(166.0)	94	1.44	(36.6)
6.50	(165.0)	97	1.42	(36.1)
6.46	(164.0)	100	1.40	(35.6)
6.42	(163.0)	103	1.38	(35.1)
6.38	(162.0)	106	1.36	(34.5)
6.34	(161.0)	109	1.34	(34.0)
6.30	(160.0)	112	1.32	(33.5)
6.26	(159.0)	115	1.30	(33.0)
6.22	(158.0)	118	1.28	(32.5)
6.18	(157.0)	121	1.26	(32.0)

1 Wear Chart: 4702



Carrier Rollers <sup>(1)</sup>  
955 Carrier Roller

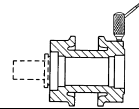
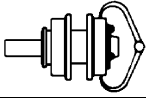

Caliper  
All

Ultrasonic  
One-piece rim

Caliper All		% Worn	Ultrasonic One-piece rim	
Inches	(mm)		Inches	(mm)
6.75	(171.5)	0	1.54	(39.1)
6.71	(170.5)	6	1.52	(38.6)
6.67	(169.5)	12	1.50	(38.1)
6.63	(168.5)	18	1.48	(37.6)
6.59	(167.5)	24	1.46	(37.1)
6.55	(166.5)	30	1.44	(36.6)
6.51	(165.5)	36	1.42	(36.1)
6.47	(164.5)	42	1.40	(35.6)
6.43	(163.5)	48	1.38	(35.1)
6.39	(162.5)	54	1.36	(34.5)
6.35	(161.5)	58	1.34	(34.0)
6.31	(160.5)	61	1.32	(33.5)
6.27	(159.5)	64	1.30	(33.0)
6.23	(158.0)	67	1.28	(32.5)
6.19	(157.0)	70	1.26	(32.0)
6.15	(156.0)	73	1.24	(31.5)
6.11	(155.0)	76	1.22	(31.0)
6.07	(154.0)	79	1.20	(30.5)
6.03	(153.0)	82	1.18	(30.0)
5.99	(152.0)	85	1.16	(29.5)
5.95	(151.0)	88	1.14	(29.0)
5.91	(150.0)	91	1.12	(28.4)
5.87	(149.0)	94	1.10	(27.9)
5.83	(148.0)	97	1.08	(27.4)
5.79	(147.0)	100	1.06	(26.9)
5.75	(146.0)	103	1.04	(26.4)
5.71	(145.0)	106	1.02	(25.9)
5.67	(144.0)	109	1.00	(25.4)
5.63	(143.0)	112	0.98	(24.9)
5.59	(142.0)	115	0.96	(24.4)
5.55	(141.0)	118	0.94	(23.9)
5.51	(140.0)	121	0.92	(23.4)

# D6, 955 - 8.00 in. (203.2 mm)

## Track Rollers <sup>(1) (2)</sup> Standardized Rollers

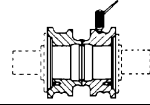
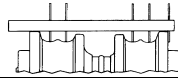
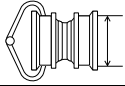

Caliper			Depth Gauge		Ultrasonic	
Inches	(mm)	% Worn	Inches	(mm)	Inches	(mm)
8.26	(210.0)	0	0.59	(15.0)	1.88	(47.8)
8.18	(208.0)	6	0.63	(16.0)	1.84	(46.7)
8.10	(205.5)	12	0.67	(17.0)	1.80	(45.7)
8.02	(203.5)	18	0.71	(18.0)	1.76	(44.7)
7.94	(201.5)	24	0.75	(19.0)	1.72	(43.7)
7.86	(199.5)	30	0.79	(20.0)	1.68	(42.7)
7.78	(197.5)	36	0.83	(21.0)	1.64	(41.7)
7.70	(195.5)	42	0.87	(22.0)	1.60	(40.6)
7.62	(193.5)	48	0.91	(23.0)	1.56	(39.6)
7.54	(191.5)	54	0.95	(24.0)	1.52	(38.6)
7.46	(189.5)	60	0.99	(25.0)	1.48	(37.6)
7.38	(187.5)	64	1.03	(26.0)	1.44	(36.6)
7.30	(185.5)	68	1.07	(27.0)	1.40	(35.6)
7.22	(183.5)	72	1.11	(28.0)	1.36	(34.5)
7.14	(181.5)	76	1.15	(29.0)	1.32	(33.5)
7.06	(179.5)	80	1.19	(30.0)	1.28	(32.5)
6.98	(177.5)	84	1.23	(31.0)	1.24	(31.5)
6.90	(175.5)	88	1.27	(32.5)	1.20	(30.5)
6.82	(173.0)	92	1.31	(33.5)	1.16	(29.5)
6.74	(171.0)	96	1.35	(34.5)	1.12	(28.4)
6.66	(169.0)	100	1.39	(35.5)	1.08	(27.4)
6.58	(167.0)	104	1.43	(36.5)	1.04	(26.4)
6.50	(165.0)	108	1.47	(37.5)	1.00	(25.4)
6.42	(163.0)	112	1.51	(38.5)	0.96	(24.4)
6.34	(161.0)	116	1.55	(39.5)	0.92	(23.4)
6.26	(159.0)	120	1.59	(40.5)	0.88	(22.4)

1 Flange diameter is 9.45 in. (240 mm)

2 Wear Chart: 5312

**Track Rollers <sup>(1) (2)</sup>**  
**Tall Flange Double Flange Rollers**  
**Standardized Press and End Collar Track Rollers**  
**Use with 7T, 8E, & 225-3735 & 36 Links**

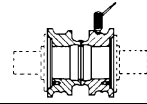
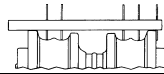
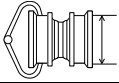

Caliper		% Worn	Depth Gauge		Ultrasonic	
Inches	(mm)		Inches	(mm)	Inches	(mm)
8.26	(210.0)	0	0.77	(19.5)	1.88	(47.8)
8.20	(208.5)	5	0.80	(20.5)	1.85	(47.0)
8.14	(207.0)	10	0.83	(21.0)	1.82	(46.2)
8.08	(205.0)	15	0.86	(22.0)	1.79	(45.5)
8.02	(203.5)	20	0.89	(22.5)	1.76	(44.7)
7.96	(202.0)	25	0.92	(23.5)	1.73	(43.9)
7.90	(200.5)	30	0.95	(24.0)	1.70	(43.2)
7.84	(199.0)	35	0.98	(25.0)	1.67	(42.4)
7.78	(197.5)	40	1.01	(25.5)	1.64	(41.7)
7.72	(196.0)	45	1.04	(26.5)	1.61	(40.9)
7.66	(194.5)	50	1.07	(27.0)	1.58	(40.1)
7.60	(193.0)	55	1.10	(28.0)	1.55	(39.4)
7.54	(191.5)	60	1.13	(28.5)	1.52	(38.6)
7.48	(190.0)	65	1.16	(29.5)	1.49	(37.8)
7.42	(188.5)	70	1.19	(30.0)	1.46	(37.1)
7.36	(187.0)	75	1.22	(31.0)	1.43	(36.3)
7.30	(185.5)	80	1.25	(32.0)	1.40	(35.6)
7.24	(184.0)	85	1.28	(32.5)	1.37	(34.8)
7.18	(182.5)	90	1.31	(33.5)	1.34	(34.0)
7.12	(181.0)	95	1.34	(34.0)	1.31	(33.3)
7.06	(179.5)	100	1.37	(35.0)	1.28	(32.5)
7.00	(178.0)	104	1.40	(35.5)	1.25	(31.8)
6.94	(176.5)	108	1.43	(36.5)	1.22	(31.0)
6.88	(175.0)	112	1.46	(37.0)	1.19	(30.2)
6.82	(173.0)	116	1.49	(38.0)	1.16	(29.5)
6.76	(171.5)	120	1.52	(38.5)	1.13	(28.7)

1 Flange diameter is 9.82 in. (249.5 mm)  
 2 Wear Chart: 6201

# D6, 955 - 8.00 in. (203.2 mm)

## Track Rollers <sup>(1) (2)</sup> Extended Life Rollers End Collar Rollers

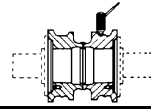
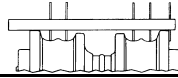
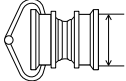

Caliper			Depth Gauge		Ultrasonic	
Inches	(mm)	% Worn	Inches	(mm)	Inches	(mm)
8.95	(227.5)	0	0.58	(14.5)	2.23	(56.6)
8.89	(226.0)	5	0.61	(15.5)	2.20	(55.9)
8.83	(224.5)	9	0.64	(16.5)	2.17	(55.1)
8.77	(223.0)	14	0.67	(17.0)	2.14	(54.4)
8.71	(221.0)	18	0.70	(18.0)	2.11	(53.6)
8.65	(219.5)	23	0.73	(18.5)	2.08	(52.8)
8.59	(218.0)	27	0.76	(19.5)	2.05	(52.1)
8.53	(216.5)	32	0.79	(20.0)	2.02	(51.3)
8.47	(215.0)	36	0.82	(21.0)	1.99	(50.5)
8.41	(213.5)	41	0.85	(21.5)	1.96	(49.8)
8.35	(212.0)	45	0.88	(22.5)	1.93	(49.0)
8.29	(210.5)	50	0.91	(23.0)	1.90	(48.3)
8.23	(209.0)	54	0.94	(24.0)	1.87	(47.5)
8.17	(207.5)	59	0.97	(24.5)	1.84	(46.7)
8.11	(206.0)	63	1.00	(25.5)	1.81	(46.0)
8.05	(204.5)	67	1.03	(26.0)	1.78	(45.2)
7.99	(203.0)	70	1.06	(27.0)	1.75	(44.5)
7.93	(201.5)	73	1.09	(27.5)	1.72	(43.7)
7.87	(200.0)	76	1.12	(28.5)	1.69	(42.9)
7.81	(198.5)	79	1.15	(29.0)	1.66	(42.2)
7.75	(197.0)	82	1.18	(30.0)	1.63	(41.4)
7.69	(195.5)	85	1.21	(30.5)	1.60	(40.6)
7.63	(194.0)	88	1.24	(31.5)	1.57	(39.9)
7.57	(192.5)	91	1.27	(32.5)	1.54	(39.1)
7.51	(191.0)	94	1.30	(33.0)	1.51	(38.4)
7.45	(189.0)	97	1.33	(34.0)	1.48	(37.6)
7.39	(187.5)	100	1.36	(34.5)	1.45	(36.8)
7.33	(186.0)	103	1.39	(35.5)	1.42	(36.1)
7.27	(184.5)	106	1.42	(36.0)	1.39	(35.3)
7.21	(183.0)	109	1.45	(37.0)	1.36	(34.5)
7.15	(181.5)	112	1.48	(37.5)	1.33	(33.8)
7.09	(180.0)	115	1.51	(38.5)	1.30	(33.0)
7.03	(178.5)	118	1.54	(39.0)	1.27	(32.3)
6.97	(177.0)	121	1.57	(40.0)	1.24	(31.5)

1 Flange diameter is 10.12 in. (257 mm)

2 Wear Chart: 5305

Track Rollers <sup>(1) (2)</sup>  
End Collar Rollers

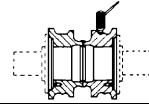
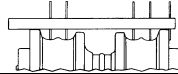
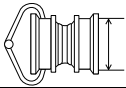

Caliper			Depth Gauge		Ultrasonic	
Inches	(mm)	% Worn	Inches	(mm)	Inches	(mm)
8.25	(209.5)	0	0.74	(19.0)	1.88	(47.8)
8.21	(208.5)	6	0.76	(19.5)	1.86	(47.2)
8.17	(207.5)	12	0.78	(20.0)	1.84	(46.7)
8.13	(206.5)	18	0.80	(20.5)	1.82	(46.2)
8.09	(205.5)	24	0.82	(21.0)	1.80	(45.7)
8.05	(204.5)	30	0.84	(21.5)	1.78	(45.2)
8.01	(203.5)	36	0.86	(22.0)	1.76	(44.7)
7.97	(202.5)	42	0.88	(22.5)	1.74	(44.2)
7.93	(201.5)	48	0.90	(23.0)	1.72	(43.7)
7.89	(200.5)	54	0.92	(23.5)	1.70	(43.2)
7.85	(199.5)	60	0.94	(24.0)	1.68	(42.7)
7.81	(198.5)	66	0.96	(24.5)	1.66	(42.2)
7.77	(197.5)	70	0.98	(25.0)	1.64	(41.7)
7.73	(196.5)	73	1.00	(25.5)	1.62	(41.1)
7.69	(195.5)	76	1.02	(26.0)	1.60	(40.6)
7.65	(194.5)	79	1.04	(26.5)	1.58	(40.1)
7.61	(193.5)	82	1.06	(27.0)	1.56	(39.6)
7.57	(192.5)	85	1.08	(27.5)	1.54	(39.1)
7.53	(191.5)	88	1.10	(28.0)	1.52	(38.6)
7.49	(190.0)	91	1.12	(28.5)	1.50	(38.1)
7.45	(189.0)	94	1.14	(29.0)	1.48	(37.6)
7.41	(188.0)	97	1.16	(29.5)	1.46	(37.1)
7.37	(187.0)	100	1.18	(30.0)	1.44	(36.6)
7.33	(186.0)	103	1.20	(30.5)	1.42	(36.1)
7.29	(185.0)	106	1.22	(31.0)	1.40	(35.6)
7.25	(184.0)	109	1.24	(31.5)	1.38	(35.1)
7.21	(183.0)	112	1.26	(32.0)	1.36	(34.5)
7.17	(182.0)	115	1.28	(32.5)	1.34	(34.0)
7.13	(181.0)	118	1.30	(33.0)	1.32	(33.5)
7.09	(180.0)	121	1.32	(33.5)	1.30	(33.0)

1 Flange diameter is 9.72 in. (247 mm)  
2 Wear Chart: 5302

# D6C, D6D, 955L - 8.00 in. (203.2 mm)

## Track Rollers <sup>(1) (2)</sup> Classic

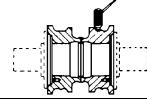
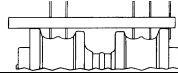

Caliper			Depth Gauge		Ultrasonic	
Inches	(mm)	% Worn	Inches	(mm)	Inches	(mm)
8.26	(210.0)	0	0.59	(15.0)	1.88	(47.8)
8.22	(209.0)	4	0.61	(15.5)	1.86	(47.2)
8.18	(208.0)	8	0.63	(16.0)	1.84	(46.7)
8.14	(207.0)	12	0.65	(16.5)	1.82	(46.2)
8.10	(205.5)	16	0.67	(17.0)	1.80	(45.7)
8.06	(204.5)	20	0.69	(17.5)	1.78	(45.2)
8.02	(203.5)	24	0.71	(18.0)	1.76	(44.7)
7.98	(202.5)	28	0.73	(18.5)	1.74	(44.2)
7.94	(201.5)	32	0.75	(19.0)	1.72	(43.7)
7.90	(200.5)	36	0.77	(19.5)	1.70	(43.2)
7.86	(199.5)	40	0.79	(20.0)	1.68	(42.7)
7.82	(198.5)	43	0.81	(20.5)	1.66	(42.2)
7.78	(197.5)	46	0.83	(21.0)	1.64	(41.7)
7.74	(196.5)	49	0.85	(21.5)	1.62	(41.1)
7.70	(195.5)	52	0.87	(22.0)	1.60	(40.6)
7.66	(194.5)	55	0.89	(22.5)	1.58	(40.1)
7.62	(193.5)	58	0.91	(23.0)	1.56	(39.6)
7.58	(192.5)	61	0.93	(23.5)	1.54	(39.1)
7.54	(191.5)	64	0.95	(24.0)	1.52	(38.6)
7.50	(190.5)	67	0.97	(24.5)	1.50	(38.1)
7.46	(189.5)	70	0.99	(25.0)	1.48	(37.6)
7.42	(188.5)	73	1.01	(25.5)	1.46	(37.1)
7.38	(187.5)	76	1.03	(26.0)	1.44	(36.6)
7.34	(186.5)	79	1.05	(26.5)	1.42	(36.1)
7.30	(185.5)	82	1.07	(27.0)	1.40	(35.6)
7.26	(184.5)	85	1.09	(27.5)	1.38	(35.1)
7.22	(183.5)	88	1.11	(28.0)	1.36	(34.5)
7.18	(182.5)	91	1.13	(28.5)	1.34	(34.0)
7.14	(181.5)	94	1.15	(29.0)	1.32	(33.5)
7.10	(180.5)	97	1.17	(29.5)	1.30	(33.0)
7.06	(179.5)	100	1.19	(30.0)	1.28	(32.5)
7.02	(178.5)	103	1.21	(30.5)	1.26	(32.0)
6.98	(177.5)	106	1.23	(31.0)	1.24	(31.5)
6.94	(176.5)	109	1.25	(32.0)	1.22	(31.0)
6.90	(175.5)	112	1.27	(32.5)	1.20	(30.5)
6.86	(174.0)	115	1.29	(33.0)	1.18	(30.0)
6.82	(173.0)	118	1.31	(33.5)	1.16	(29.5)
6.78	(172.0)	121	1.33	(34.0)	1.14	(29.0)

1 Flange diameter is 9.45 in. (240 mm)

2 Wear Chart: 5311

**Track Links <sup>(1)</sup>  
Heavy Duty and Rotating Bushing Tracks  
61-9239 & 40  
165-1758 & 59**

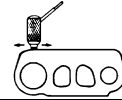
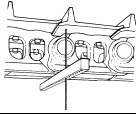

Depth Gauge			Ultrasonic	
Inches	(mm)	% Worn	Inches	(mm)
5.50	(139.5)	0	1.66	(42.2)
5.48	(139.0)	4	1.64	(41.7)
5.46	(138.5)	8	1.62	(41.1)
5.44	(138.0)	12	1.60	(40.6)
5.42	(137.5)	16	1.58	(40.1)
5.40	(137.0)	20	1.56	(39.6)
5.38	(136.5)	24	1.54	(39.1)
5.36	(136.0)	28	1.52	(38.6)
5.34	(135.5)	32	1.50	(38.1)
5.32	(135.0)	36	1.48	(37.6)
5.30	(134.5)	40	1.46	(37.1)
5.28	(134.0)	44	1.44	(36.6)
5.26	(133.5)	48	1.42	(36.1)
5.24	(133.0)	52	1.40	(35.6)
5.22	(132.5)	56	1.38	(35.1)
5.20	(132.0)	60	1.36	(34.5)
5.18	(131.5)	64	1.34	(34.0)
5.16	(131.0)	68	1.32	(33.5)
5.14	(130.5)	72	1.30	(33.0)
5.12	(130.0)	76	1.28	(32.5)
5.10	(129.5)	80	1.26	(32.0)
5.08	(129.0)	84	1.24	(31.5)
5.06	(128.5)	88	1.22	(31.0)
5.04	(128.0)	92	1.20	(30.5)
5.02	(127.5)	96	1.18	(30.0)
5.00	(127.0)	100	1.16	(29.5)
4.98	(126.5)	104	1.14	(29.0)
4.96	(126.0)	108	1.12	(28.4)
4.94	(125.5)	112	1.10	(27.9)
4.92	(125.0)	116	1.08	(27.4)
4.90	(124.5)	120	1.06	(26.9)

# D7E - 8.50 in. (215.9 mm)

## Bushings <sup>(1)</sup> External Wear Heavy Duty Track

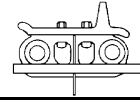
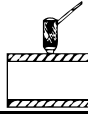
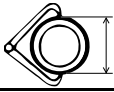

Caliper		Allowable Wear		Ultrasonic		Depth Gauge	
Inches	(mm)	Lesser % Worn	Greater % Worn	Inches	(mm)	Inches	(mm)
3.11	(79.0)	0	0	0.60	(15.2)	3.86	(98.0)
3.09	(78.5)	10	8	0.58	(14.7)	3.84	(97.5)
3.07	(78.0)	20	16	0.56	(14.2)	3.82	(97.0)
3.05	(77.5)	30	24	0.54	(13.7)	3.80	(96.5)
3.03	(77.0)	40	32	0.52	(13.2)	3.78	(96.0)
3.01	(76.5)	50	40	0.50	(12.7)	3.76	(95.5)
2.99	(75.9)	60	44	0.48	(12.2)	3.74	(95.0)
2.97	(75.4)	68	48	0.46	(11.7)	3.72	(94.5)
2.95	(74.9)	72	52	0.44	(11.2)	3.70	(94.0)
2.93	(74.4)	76	56	0.42	(10.7)	3.68	(93.5)
2.91	(73.9)	80	60	0.40	(10.2)	3.66	(93.0)
2.89	(73.4)	84	64	0.38	(9.7)	3.64	(92.5)
2.87	(72.9)	88	68	0.36	(9.1)	3.62	(91.9)
2.85	(72.4)	92	72	0.34	(8.6)	3.60	(91.4)
2.83	(71.9)	96	76	0.32	(8.1)	3.58	(90.9)
2.81	(71.4)	100	80	0.30	(7.6)	3.56	(90.4)
2.79	(70.9)	104	84	0.28	(7.1)	3.54	(89.9)
2.77	(70.4)	108	88	0.26	(6.6)	3.52	(89.4)
2.75	(69.9)	112	92	0.24	(6.1)	3.50	(88.9)
2.73	(69.3)	116	96	0.22	(5.6)	3.48	(88.4)
2.71	(68.8)	120	100	0.20	(5.1)	3.46	(87.9)
2.69	(68.3)		104	0.18	(4.6)	3.44	(87.4)
2.67	(67.8)		108	0.16	(4.1)	3.42	(86.9)
2.65	(67.3)		112	0.14	(3.6)	3.40	(86.4)
2.63	(66.8)		116	0.12	(3.0)	3.38	(85.9)
2.61	(66.3)		120	0.10	(2.5)	3.36	(85.3)



**Bushings <sup>(1)</sup>  
Rotating Bushing Track**

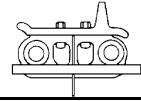
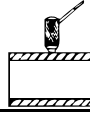
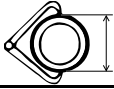

Caliper			Ultrasonic		Depth Gauge	
Inches	(mm)	% Worn	Inches	(mm)	Inches	(mm)
3.11	(79.0)	0	0.61	(15.5)	3.86	(98.0)
3.07	(78.0)	8	0.59	(15.0)	3.84	(97.5)
3.03	(77.0)	16	0.57	(14.5)	3.82	(97.0)
2.99	(75.9)	24	0.55	(14.0)	3.80	(96.5)
2.95	(74.9)	32	0.53	(13.5)	3.78	(96.0)
2.91	(73.9)	40	0.51	(13.0)	3.76	(95.5)
2.87	(72.9)	44	0.49	(12.4)	3.74	(95.0)
2.83	(71.9)	48	0.47	(11.9)	3.72	(94.5)
2.79	(70.9)	52	0.45	(11.4)	3.70	(94.0)
2.75	(69.9)	56	0.43	(10.9)	3.68	(93.5)
2.71	(68.8)	60	0.41	(10.4)	3.66	(93.0)
2.67	(67.8)	64	0.39	(9.9)	3.64	(92.5)
2.63	(66.8)	68	0.37	(9.4)	3.62	(91.9)
2.59	(65.8)	72	0.35	(8.9)	3.60	(91.4)
2.55	(64.8)	76	0.33	(8.4)	3.58	(90.9)
2.51	(63.8)	80	0.31	(7.9)	3.56	(90.4)
2.47	(62.7)	84	0.29	(7.4)	3.54	(89.9)
2.43	(61.7)	88	0.27	(6.9)	3.52	(89.4)
2.39	(60.7)	92	0.25	(6.3)	3.50	(88.9)
2.35	(59.7)	96	0.23	(5.8)	3.48	(88.4)
2.31	(58.7)	100	0.21	(5.3)	3.46	(87.9)
2.27	(57.7)	104	0.19	(4.8)	3.44	(87.4)
2.23	(56.6)	108	0.17	(4.3)	3.42	(86.9)
2.19	(55.6)	112	0.15	(3.8)	3.40	(86.4)
2.15	(54.6)	116	0.13	(3.3)	3.38	(85.9)
2.11	(53.6)	120	0.11	(2.8)	3.36	(85.3)

# D7E - 8.50 in. (215.9 mm)

## Track Shoes <sup>(1)</sup> Extreme Service

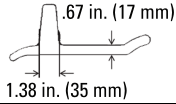
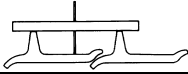

### Allowable Wear

Depth Gauge		High Impact	Low Impact	Ultrasonic	
Inches	(mm)	% Worn	% Worn	Inches	(mm)
3.20	(81.5)	0	0	3.90	(99.1)
3.10	(78.5)	6	5	3.80	(96.5)
3.00	(76.0)	12	10	3.70	(94.0)
2.90	(73.5)	18	15	3.60	(91.4)
2.80	(71.0)	24	20	3.50	(88.9)
2.70	(68.5)	30	25	3.40	(86.4)
2.60	(66.0)	36	30	3.30	(83.8)
2.50	(63.5)	42	35	3.20	(81.3)
2.40	(61.0)	48	40	3.10	(78.7)
2.30	(58.5)	54	45	3.00	(76.2)
2.20	(56.0)	60	50	2.90	(73.7)
2.10	(53.5)	66	55	2.80	(71.1)
2.00	(51.0)	72	60	2.70	(68.6)
1.90	(48.5)	78	64	2.60	(66.0)
1.80	(45.5)	84	68	2.50	(63.5)
1.70	(43.0)	90	72	2.40	(61.0)
1.60	(40.5)	95	76	2.30	(58.4)
1.50	(38.0)	100	80	2.20	(55.9)
1.40	(35.5)	105	84	2.10	(53.3)
1.30	(33.0)	110	88	2.00	(50.8)
1.20	(30.5)	115	92	1.90	(48.3)
1.10	(28.0)	120	96	1.80	(45.7)
1.00	(25.5)		100	1.70	(43.2)
0.90	(23.0)		104	1.60	(40.6)
0.80	(20.5)		108	1.50	(38.1)
0.70	(18.0)		112	1.40	(35.6)
0.60	(15.0)		116	1.30	(33.0)
0.50	(12.5)		120	1.20	(30.5)

**Track Shoes <sup>(1)</sup>  
Moderate Service**

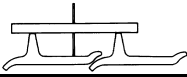

Depth Gauge		High Impact	Low Impact	Ultrasonic	
Inches	(mm)	% Worn	% Worn	Inches	(mm)
2.90	(73.5)	0	0	3.45	(87.6)
2.80	(71.0)	8	6	3.35	(85.1)
2.70	(68.5)	16	12	3.25	(82.6)
2.60	(66.0)	23	18	3.15	(80.0)
2.50	(63.5)	30	24	3.05	(77.5)
2.40	(61.0)	37	30	2.95	(74.9)
2.30	(58.5)	44	35	2.85	(72.4)
2.20	(56.0)	51	40	2.75	(69.9)
2.10	(53.5)	58	45	2.65	(67.3)
2.00	(51.0)	65	50	2.55	(64.8)
1.90	(48.5)	72	55	2.45	(62.2)
1.80	(45.5)	79	60	2.35	(59.7)
1.70	(43.0)	86	65	2.25	(57.2)
1.60	(40.5)	93	70	2.15	(54.6)
1.50	(38.0)	100	75	2.05	(52.1)
1.40	(35.5)	107	80	1.95	(49.5)
1.30	(33.0)	114	85	1.85	(47.0)
1.20	(30.5)	121	90	1.75	(44.5)
1.10	(28.0)		95	1.65	(41.9)
1.00	(25.5)		100	1.55	(39.4)
0.90	(23.0)		105	1.45	(36.8)
0.80	(20.5)		110	1.35	(34.3)
0.70	(18.0)		115	1.25	(31.8)
0.60	(15.0)		120	1.15	(29.2)

# D7E - 8.50 in. (215.9 mm)

## Idlers <sup>(1)</sup> <sup>(2)</sup> <sup>(3)</sup>

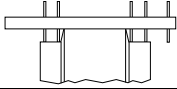

**Depth Gauge**

Inches	(mm)	% Worn
0.78	(20.0)	0
0.82	(21.0)	12
0.86	(22.0)	24
0.90	(23.0)	36
0.94	(24.0)	48
0.98	(25.0)	60
1.02	(26.0)	68
1.06	(27.0)	72
1.10	(28.0)	76
1.14	(29.0)	80
1.18	(30.0)	84
1.22	(31.0)	88
1.26	(32.0)	92
1.30	(33.0)	96
1.34	(34.0)	100
1.38	(35.0)	104
1.42	(36.0)	108
1.46	(37.0)	112
1.50	(38.0)	116
1.54	(39.0)	120

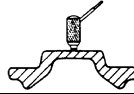

**Ultrasonic**

**Center Flange Wear**

Inches	(mm)	Inches	(mm)
0.48	(12.2)	0.00	(0.0)
0.44	(11.2)	0.04	(1.0)
0.40	(10.2)	0.08	(2.0)
0.36	(9.1)	0.12	(3.0)
0.32	(8.1)	0.16	(4.0)
0.28	(7.1)	0.20	(5.0)
0.24	(6.1)	0.24	(6.0)
0.20	(5.1)	0.28	(7.0)
0.16	(4.1)	0.32	(8.0)
0.12	(3.0)	0.36	(9.0)
0.08	(2.0)	0.40	(10.0)
0.04	(1.0)	0.44	(11.0)

### NOTE

Ultrasonic measurement is to determine flange wear only.

- 1 Flange width is 4.02 in. (102 mm)
- 2 New tread diameter is 23 in. (585 mm)
- 3 Wear Chart: 4427

Carrier Rollers <sup>(1)</sup>

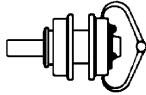

Caliper		
Inches	(mm)	% Worn
7.50	(190.5)	0
7.42	(188.5)	8
7.34	(186.5)	16
7.26	(184.5)	24
7.18	(182.5)	32
7.10	(180.5)	40
7.02	(178.5)	48
6.94	(176.5)	52
6.86	(174.0)	56
6.78	(172.0)	60
6.70	(170.0)	64
6.62	(168.0)	68
6.54	(166.0)	72
6.46	(164.0)	76
6.38	(162.0)	80
6.30	(160.0)	84
6.22	(158.0)	88
6.14	(156.0)	92
6.06	(154.0)	96
5.98	(152.0)	100
5.90	(150.0)	104
5.82	(148.0)	108
5.74	(146.0)	112
5.66	(144.0)	116
5.58	(141.5)	120

NOTE

For certain D7E LGP models, use Track Roller wear chart for Carrier Rollers.  
Reference Special Instruction REHS8573.

# D7E - 8.50 in. (215.9 mm)

## Track Rollers <sup>(1) (2)</sup> End Collar and Standardized Rollers

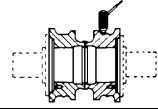
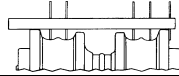
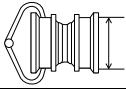

Caliper		% Worn	Depth Gauge		Ultrasonic	
Inches	(mm)		Inches	(mm)	Inches	(mm)
8.76	(222.5)	0	0.63	(16.0)	2.06	(52.3)
8.68	(220.5)	6	0.67	(17.0)	2.02	(51.3)
8.60	(218.5)	12	0.71	(18.0)	1.98	(50.3)
8.52	(216.5)	18	0.75	(19.0)	1.94	(49.3)
8.44	(214.5)	24	0.79	(20.0)	1.90	(48.3)
8.36	(212.5)	30	0.83	(21.0)	1.86	(47.2)
8.28	(210.5)	36	0.87	(22.0)	1.82	(46.2)
8.20	(208.5)	42	0.91	(23.0)	1.78	(45.2)
8.12	(206.0)	48	0.95	(24.0)	1.74	(44.2)
8.04	(204.0)	54	0.99	(25.0)	1.70	(43.2)
7.96	(202.0)	60	1.03	(26.0)	1.66	(42.2)
7.88	(200.0)	64	1.07	(27.0)	1.62	(41.1)
7.80	(198.0)	68	1.11	(28.0)	1.58	(40.1)
7.72	(196.0)	72	1.15	(29.0)	1.54	(39.1)
7.64	(194.0)	76	1.19	(30.0)	1.50	(38.1)
7.56	(192.0)	80	1.23	(31.0)	1.46	(37.1)
7.48	(190.0)	84	1.27	(32.5)	1.42	(36.1)
7.40	(188.0)	88	1.31	(33.5)	1.38	(35.1)
7.32	(186.0)	92	1.35	(34.5)	1.34	(34.0)
7.24	(184.0)	96	1.39	(35.5)	1.30	(33.0)
7.16	(182.0)	100	1.43	(36.5)	1.26	(32.0)
7.08	(180.0)	104	1.47	(37.5)	1.22	(31.0)
7.00	(178.0)	108	1.51	(38.5)	1.18	(30.0)
6.92	(176.0)	112	1.55	(39.5)	1.14	(29.0)
6.84	(173.5)	116	1.59	(40.5)	1.10	(27.9)
6.76	(171.5)	120	1.63	(41.5)	1.06	(26.9)

1 Flange diameter is 10.04 in. (255 mm)

2 Wear Chart: 5327

**Track Rollers <sup>(1) (2)</sup>  
Tall Flange Double Flange Rollers**

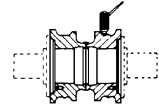
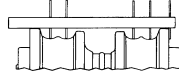
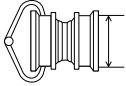

Caliper		% Worn	Depth Gauge		Ultrasonic	
Inches	(mm)		Inches	(mm)	Inches	(mm)
8.76	(222.5)	0	0.82	(21.0)	2.06	(52.3)
8.68	(220.5)	8	0.86	(22.0)	2.02	(51.3)
8.60	(218.5)	16	0.90	(23.0)	1.98	(50.3)
8.52	(216.5)	24	0.94	(24.0)	1.94	(49.3)
8.44	(214.5)	32	0.98	(25.0)	1.90	(48.3)
8.36	(212.5)	40	1.02	(26.0)	1.86	(47.2)
8.28	(210.5)	46	1.06	(27.0)	1.82	(46.2)
8.20	(208.5)	52	1.10	(28.0)	1.78	(45.2)
8.12	(206.0)	58	1.14	(29.0)	1.74	(44.2)
8.04	(204.0)	64	1.18	(30.0)	1.70	(43.2)
7.96	(202.0)	70	1.22	(31.0)	1.66	(42.2)
7.88	(200.0)	76	1.26	(32.0)	1.62	(41.1)
7.80	(198.0)	82	1.30	(33.0)	1.58	(40.1)
7.72	(196.0)	88	1.34	(34.0)	1.54	(39.1)
7.64	(194.0)	94	1.38	(35.0)	1.50	(38.1)
7.56	(192.0)	100	1.42	(36.0)	1.46	(37.1)
7.48	(190.0)	106	1.46	(37.0)	1.42	(36.1)
7.40	(188.0)	112	1.50	(38.0)	1.38	(35.1)
7.32	(186.0)	118	1.54	(39.0)	1.34	(34.0)
7.24	(184.0)	124	1.58	(40.0)	1.30	(33.0)

1 Flange diameter is 10.43 in. (265 mm)  
2 Wear Chart: 5328

# D7, 977 - 8.50 in. (215.9 mm)

**Track Links <sup>(1)</sup>  
Enhanced SALT Track  
233-0385 & 86  
289-3083 & 84**

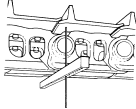

Depth Gauge			Ultrasonic	
Inches	(mm)	% Worn	Inches	(mm)
5.31	(135.0)	0	1.62	(41.1)
5.29	(134.5)	5	1.60	(40.6)
5.27	(134.0)	10	1.58	(40.1)
5.25	(133.5)	15	1.56	(39.6)
5.23	(133.0)	20	1.54	(39.1)
5.21	(132.5)	25	1.52	(38.6)
5.19	(132.0)	30	1.50	(38.1)
5.17	(131.5)	35	1.48	(37.6)
5.15	(131.0)	40	1.46	(37.1)
5.13	(130.5)	45	1.44	(36.6)
5.11	(130.0)	50	1.42	(36.1)
5.09	(129.5)	55	1.40	(35.6)
5.07	(129.0)	60	1.38	(35.1)
5.05	(128.5)	64	1.36	(34.5)
5.03	(128.0)	67	1.34	(34.0)
5.01	(127.5)	70	1.32	(33.5)
4.99	(126.5)	73	1.30	(33.0)
4.97	(126.0)	76	1.28	(32.5)
4.95	(125.5)	79	1.26	(32.0)
4.93	(125.0)	82	1.24	(31.5)
4.91	(124.5)	85	1.22	(31.0)
4.89	(124.0)	88	1.20	(30.5)
4.87	(123.5)	91	1.18	(30.0)
4.85	(123.0)	94	1.16	(29.5)
4.83	(122.5)	97	1.14	(29.0)
4.81	(122.0)	100	1.12	(28.4)
4.79	(121.5)	103	1.10	(27.9)
4.77	(121.0)	106	1.08	(27.4)
4.75	(120.5)	109	1.06	(26.9)
4.73	(120.0)	112	1.04	(26.4)
4.71	(119.5)	115	1.02	(25.9)
4.69	(119.0)	118	1.00	(25.4)
4.67	(118.5)	121	0.98	(24.9)



# D7, 977, 571, 572 - 8.50 in. (215.9 mm)

## Track Links <sup>(1)</sup> Extended Life Links 7T-4657 & 58

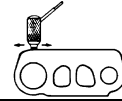
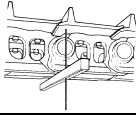

### Depth Gauge

### Ultrasonic

Inches	(mm)	% Worn	Inches	(mm)
5.23	(133.0)	0	1.64	(41.7)
5.21	(132.5)	4	1.62	(41.1)
5.19	(132.0)	8	1.60	(40.6)
5.17	(131.5)	12	1.58	(40.1)
5.15	(131.0)	16	1.56	(39.6)
5.13	(130.5)	20	1.54	(39.1)
5.11	(130.0)	24	1.52	(38.6)
5.09	(129.5)	28	1.50	(38.1)
5.07	(129.0)	32	1.48	(37.6)
5.05	(128.5)	36	1.46	(37.1)
5.03	(128.0)	40	1.44	(36.6)
5.01	(127.5)	44	1.42	(36.1)
4.99	(126.5)	48	1.40	(35.6)
4.97	(126.0)	52	1.38	(35.1)
4.95	(125.5)	56	1.36	(34.5)
4.93	(125.0)	60	1.34	(34.0)
4.91	(124.5)	64	1.32	(33.5)
4.89	(124.0)	68	1.30	(33.0)
4.87	(123.5)	72	1.28	(32.5)
4.85	(123.0)	76	1.26	(32.0)
4.83	(122.5)	80	1.24	(31.5)
4.81	(122.0)	84	1.22	(31.0)
4.79	(121.5)	88	1.20	(30.5)
4.77	(121.0)	92	1.18	(30.0)
4.75	(120.5)	96	1.16	(29.5)
4.73	(120.0)	100	1.14	(29.0)
4.71	(119.5)	103	1.12	(28.4)
4.69	(119.0)	106	1.10	(27.9)
4.67	(118.5)	109	1.08	(27.4)
4.65	(118.0)	112	1.06	(26.9)
4.63	(117.5)	115	1.04	(26.4)
4.61	(117.0)	118	1.02	(25.9)
4.59	(116.5)	121	1.00	(25.4)

# D7, 977, 571, 572 - 8.50 in. (215.9 mm)

## Track Links <sup>(1)</sup> 8S-2589 & 90

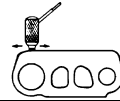
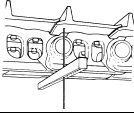

Depth Gauge			Ultrasonic	
Inches	(mm)	% Worn	Inches	(mm)
4.93	(125.0)	0	1.35	(34.3)
4.91	(124.5)	5	1.33	(33.8)
4.89	(124.0)	10	1.31	(33.3)
4.87	(123.5)	15	1.29	(32.8)
4.85	(123.0)	20	1.27	(32.3)
4.83	(122.5)	25	1.25	(31.8)
4.81	(122.0)	30	1.23	(31.2)
4.79	(121.5)	35	1.21	(30.7)
4.77	(121.0)	40	1.19	(30.2)
4.75	(120.5)	45	1.17	(29.7)
4.73	(120.0)	50	1.15	(29.2)
4.71	(119.5)	55	1.13	(28.7)
4.69	(119.0)	60	1.11	(28.2)
4.67	(118.5)	64	1.09	(27.7)
4.65	(118.0)	68	1.07	(27.2)
4.63	(117.5)	72	1.05	(26.7)
4.61	(117.0)	76	1.03	(26.2)
4.59	(116.5)	80	1.01	(25.7)
4.57	(116.0)	84	0.99	(25.1)
4.55	(115.5)	88	0.97	(24.6)
4.53	(115.0)	92	0.95	(24.1)
4.51	(114.5)	96	0.93	(23.6)
4.49	(114.0)	100	0.91	(23.1)
4.47	(113.5)	104	0.89	(22.6)
4.45	(113.0)	108	0.87	(22.1)
4.43	(112.5)	112	0.85	(21.6)
4.41	(112.0)	116	0.83	(21.1)
4.39	(111.5)	120	0.81	(20.6)

## D7, 977, 571, 572 - 8.50 in. (215.9 mm)

### Track Links <sup>(1)</sup> Classic 188-5251 & 52

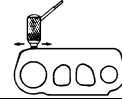
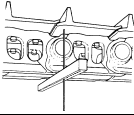

Depth Gauge			Ultrasonic	
Inches	(mm)	% Worn	Inches	(mm)
4.94	(125.5)	0	1.35	(34.3)
4.92	(125.0)	5	1.33	(33.8)
4.90	(124.5)	10	1.31	(33.3)
4.88	(124.0)	15	1.29	(32.8)
4.86	(123.5)	20	1.27	(32.3)
4.84	(123.0)	25	1.25	(31.8)
4.82	(122.5)	30	1.23	(31.2)
4.80	(122.0)	35	1.21	(30.7)
4.78	(121.5)	40	1.19	(30.2)
4.76	(121.0)	44	1.17	(29.7)
4.74	(120.5)	48	1.15	(29.2)
4.72	(120.0)	52	1.13	(28.7)
4.70	(119.5)	56	1.11	(28.2)
4.68	(119.0)	60	1.09	(27.7)
4.66	(118.5)	64	1.07	(27.2)
4.64	(118.0)	68	1.05	(26.7)
4.62	(117.5)	72	1.03	(26.2)
4.60	(117.0)	76	1.01	(25.7)
4.58	(116.5)	80	0.99	(25.1)
4.56	(116.0)	84	0.97	(24.6)
4.54	(115.5)	88	0.95	(24.1)
4.52	(115.0)	92	0.93	(23.6)
4.50	(114.5)	96	0.91	(23.1)
4.48	(114.0)	100	0.89	(22.6)
4.46	(113.5)	104	0.87	(22.1)
4.44	(113.0)	108	0.85	(21.6)
4.42	(112.5)	112	0.83	(21.1)
4.40	(112.0)	116	0.81	(20.6)
4.38	(111.5)	120	0.79	(20.1)

# D7, 977 - 8.50 in. (215.9 mm)

## Bushings <sup>(1)</sup> External Wear Sealed & Lubricated Track Enhanced SALT Track

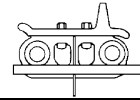
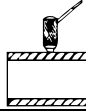

Caliper		Allowable Wear		Ultrasonic		Depth Gauge	
Inches	(mm)	Lesser % Worn	Greater % Worn	Inches	(mm)	Inches	(mm)
3.11	(79.0)	0	0	0.60	(15.2)	3.78	(96.0)
3.09	(78.5)	12	10	0.58	(14.7)	3.76	(95.5)
3.07	(78.0)	22	20	0.56	(14.2)	3.74	(95.0)
3.05	(77.5)	28	30	0.54	(13.7)	3.72	(94.5)
3.03	(77.0)	34	36	0.52	(13.2)	3.70	(94.0)
3.01	(76.5)	40	40	0.50	(12.7)	3.68	(93.5)
2.99	(75.9)	46	44	0.48	(12.2)	3.66	(93.0)
2.97	(75.4)	52	48	0.46	(11.7)	3.64	(92.5)
2.95	(74.9)	58	52	0.44	(11.2)	3.62	(91.9)
2.93	(74.4)	64	56	0.42	(10.7)	3.60	(91.4)
2.91	(73.9)	70	60	0.40	(10.2)	3.58	(90.9)
2.89	(73.4)	76	64	0.38	(9.7)	3.56	(90.4)
2.87	(72.9)	82	68	0.36	(9.1)	3.54	(89.9)
2.85	(72.4)	88	72	0.34	(8.6)	3.52	(89.4)
2.83	(71.9)	94	76	0.32	(8.1)	3.50	(88.9)
2.81	(71.4)	100	80	0.30	(7.6)	3.48	(88.4)
2.79	(70.9)	106	84	0.28	(7.1)	3.46	(87.9)
2.77	(70.4)	112	88	0.26	(6.6)	3.44	(87.4)
2.75	(69.9)	118	92	0.24	(6.1)	3.42	(86.9)
2.73	(69.3)	124	96	0.22	(5.6)	3.40	(86.4)
2.71	(68.8)		100	0.20	(5.1)	3.38	(85.9)
2.69	(68.3)		104	0.18	(4.6)	3.36	(85.3)
2.67	(67.8)		108	0.16	(4.1)	3.34	(84.8)
2.65	(67.3)		112	0.14	(3.6)	3.32	(84.3)
2.63	(66.8)		116	0.12	(3.0)	3.30	(83.8)
2.61	(66.3)		120	0.10	(2.5)	3.28	(83.3)

**Bushings <sup>(1)</sup>  
External Wear  
Sealed & Lubricated Track  
Extended Life Bushings  
Use with 7T Links**

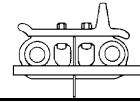
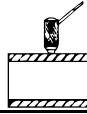
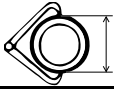

Caliper		Allowable Wear		Ultrasonic		Depth Gauge	
Inches	(mm)	Lesser % Worn	Greater % Worn	Inches	(mm)	Inches	(mm)
3.04	(77.2)	0	0	0.56	(14.2)	3.69	(93.7)
3.02	(76.7)	12	10	0.54	(13.7)	3.67	(93.2)
3.00	(76.2)	24	20	0.52	(13.2)	3.65	(92.7)
2.98	(75.7)	36	30	0.50	(12.7)	3.63	(92.2)
2.96	(75.2)	48	40	0.48	(12.2)	3.61	(91.7)
2.94	(74.7)	58	50	0.46	(11.7)	3.59	(91.2)
2.92	(74.2)	64	56	0.44	(11.2)	3.57	(90.7)
2.90	(73.7)	70	60	0.42	(10.7)	3.55	(90.2)
2.88	(73.2)	76	64	0.40	(10.2)	3.53	(89.7)
2.86	(72.6)	82	68	0.38	(9.7)	3.51	(89.2)
2.84	(72.1)	88	72	0.36	(9.1)	3.49	(88.6)
2.82	(71.6)	94	76	0.34	(8.6)	3.47	(88.1)
2.80	(71.1)	100	80	0.32	(8.1)	3.45	(87.6)
2.78	(70.6)	106	84	0.30	(7.6)	3.43	(87.1)
2.76	(70.1)	112	88	0.28	(7.1)	3.41	(86.6)
2.74	(69.6)	118	92	0.26	(6.6)	3.39	(86.1)
2.72	(69.1)	124	96	0.24	(6.1)	3.37	(85.6)
2.70	(68.6)		100	0.22	(5.6)	3.35	(85.1)
2.68	(68.1)		104	0.20	(5.1)	3.33	(84.6)
2.66	(67.6)		108	0.18	(4.6)	3.31	(84.1)
2.64	(67.1)		112	0.16	(4.1)	3.29	(83.6)
2.62	(66.5)		116	0.14	(3.6)	3.27	(83.1)
2.60	(66.0)		120	0.12	(3.0)	3.25	(82.6)

**D7, 977, 571, 572 - 8.50 in. (215.9 mm)**

**Bushings <sup>(1)</sup>  
External Wear  
Sealed & Lubricated Track  
Use with 8S Links**

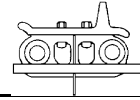
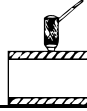
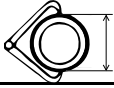

Caliper		Allowable Wear		Ultrasonic		Depth Gauge	
Inches	(mm)	Lesser % Worn	Greater % Worn	Inches	(mm)	Inches	(mm)
2.93	(74.4)	0	0	0.51	(13.0)	3.65	(92.7)
2.92	(74.2)	6	5	0.50	(12.7)	3.64	(92.5)
2.91	(73.9)	12	10	0.49	(12.4)	3.63	(92.2)
2.90	(73.7)	18	15	0.48	(12.2)	3.62	(91.9)
2.89	(73.4)	24	20	0.47	(11.9)	3.61	(91.7)
2.88	(73.2)	30	25	0.46	(11.7)	3.60	(91.4)
2.87	(72.9)	36	30	0.45	(11.4)	3.59	(91.2)
2.86	(72.6)	42	35	0.44	(11.2)	3.58	(90.9)
2.85	(72.4)	48	40	0.43	(10.9)	3.57	(90.7)
2.84	(72.1)	54	45	0.42	(10.7)	3.56	(90.4)
2.83	(71.9)	60	50	0.41	(10.4)	3.55	(90.2)
2.82	(71.6)	66	55	0.40	(10.2)	3.54	(89.9)
2.81	(71.4)	72	60	0.39	(9.9)	3.53	(89.7)
2.80	(71.1)	78	65	0.38	(9.7)	3.52	(89.4)
2.79	(70.9)	84	70	0.37	(9.4)	3.51	(89.2)
2.78	(70.6)	88	72	0.36	(9.1)	3.50	(88.9)
2.77	(70.4)	91	74	0.35	(8.9)	3.49	(88.6)
2.76	(70.1)	94	76	0.34	(8.6)	3.48	(88.4)
2.75	(69.9)	97	78	0.33	(8.4)	3.47	(88.1)
2.74	(69.6)	100	80	0.32	(8.1)	3.46	(87.9)
2.73	(69.3)	103	82	0.31	(7.9)	3.45	(87.6)
2.72	(69.1)	106	84	0.30	(7.6)	3.44	(87.4)
2.71	(68.8)	109	86	0.29	(7.4)	3.43	(87.1)
2.70	(68.6)	112	88	0.28	(7.1)	3.42	(86.9)
2.69	(68.3)	115	90	0.27	(6.9)	3.41	(86.6)
2.68	(68.1)	118	92	0.26	(6.6)	3.40	(86.4)
2.67	(67.8)	121	94	0.25	(6.3)	3.39	(86.1)
2.66	(67.6)		96	0.24	(6.1)	3.38	(85.9)
2.65	(67.3)		98	0.23	(5.8)	3.37	(85.6)
2.64	(67.1)		100	0.22	(5.6)	3.36	(85.3)
2.63	(66.8)		102	0.21	(5.3)	3.35	(85.1)
2.62	(66.5)		104	0.20	(5.1)	3.34	(84.8)
2.61	(66.3)		106	0.19	(4.8)	3.33	(84.6)
2.60	(66.0)		108	0.18	(4.6)	3.32	(84.3)
2.59	(65.8)		110	0.17	(4.3)	3.31	(84.1)
2.58	(65.5)		112	0.16	(4.1)	3.30	(83.8)
2.57	(65.3)		114	0.15	(3.8)	3.29	(83.6)
2.56	(65.0)		116	0.14	(3.6)	3.28	(83.3)
2.55	(64.8)		118	0.13	(3.3)	3.27	(83.1)
2.54	(64.5)		120	0.12	(3.0)	3.26	(82.8)

Bushings <sup>(1)</sup>  
 Classic  
 External Wear  
 Sealed & Lubricated Track

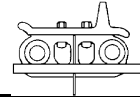
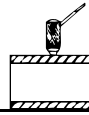
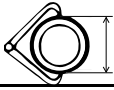

Caliper		Allowable Wear		Ultrasonic		Depth Gauge	
Inches	(mm)	Lesser % Worn	Greater % Worn	Inches	(mm)	Inches	(mm)
2.93	(74.4)	0	0	0.51	(13.0)	3.65	(92.7)
2.92	(74.2)	6	5	0.50	(12.7)	3.64	(92.5)
2.91	(73.9)	12	10	0.49	(12.4)	3.63	(92.2)
2.90	(73.7)	18	15	0.48	(12.2)	3.62	(91.9)
2.89	(73.4)	24	20	0.47	(11.9)	3.61	(91.7)
2.88	(73.2)	30	25	0.46	(11.7)	3.60	(91.4)
2.87	(72.9)	36	30	0.45	(11.4)	3.59	(91.2)
2.86	(72.6)	42	35	0.44	(11.2)	3.58	(90.9)
2.85	(72.4)	48	40	0.43	(10.9)	3.57	(90.7)
2.84	(72.1)	54	45	0.42	(10.7)	3.56	(90.4)
2.83	(71.9)	60	50	0.41	(10.4)	3.55	(90.2)
2.82	(71.6)	66	55	0.40	(10.2)	3.54	(89.9)
2.81	(71.4)	72	60	0.39	(9.9)	3.53	(89.7)
2.80	(71.1)	78	65	0.38	(9.7)	3.52	(89.4)
2.79	(70.9)	84	70	0.37	(9.4)	3.51	(89.2)
2.78	(70.6)	88	72	0.36	(9.1)	3.50	(88.9)
2.77	(70.4)	91	74	0.35	(8.9)	3.49	(88.6)
2.76	(70.1)	94	76	0.34	(8.6)	3.48	(88.4)
2.75	(69.9)	97	78	0.33	(8.4)	3.47	(88.1)
2.74	(69.6)	100	80	0.32	(8.1)	3.46	(87.9)
2.73	(69.3)	103	82	0.31	(7.9)	3.45	(87.6)
2.72	(69.1)	106	84	0.30	(7.6)	3.44	(87.4)
2.71	(68.8)	109	86	0.29	(7.4)	3.43	(87.1)
2.70	(68.6)	112	88	0.28	(7.1)	3.42	(86.9)
2.69	(68.3)	115	90	0.27	(6.9)	3.41	(86.6)
2.68	(68.1)	121	92	0.26	(6.6)	3.40	(86.4)
2.67	(67.8)		94	0.25	(6.3)	3.39	(86.1)
2.66	(67.6)		96	0.24	(6.1)	3.38	(85.9)
2.65	(67.3)		98	0.23	(5.8)	3.37	(85.6)
2.64	(67.1)		100	0.22	(5.6)	3.36	(85.3)
2.63	(66.8)		102	0.21	(5.3)	3.35	(85.1)
2.62	(66.5)		104	0.20	(5.1)	3.34	(84.8)
2.61	(66.3)		106	0.19	(4.8)	3.33	(84.6)
2.60	(66.0)		108	0.18	(4.6)	3.32	(84.3)
2.59	(65.8)		110	0.17	(4.3)	3.31	(84.1)
2.58	(65.5)		112	0.16	(4.1)	3.30	(83.8)
2.57	(65.3)		114	0.15	(3.8)	3.29	(83.6)
2.56	(65.0)		116	0.14	(3.6)	3.28	(83.3)
2.55	(64.8)		118	0.13	(3.3)	3.27	(83.1)
2.54	(64.5)		120	0.12	(3.0)	3.26	(82.8)

**D7, 977, 571, 572 - 8.50 in. (215.9 mm)**

**Pins and Bushings <sup>(1)</sup>  
Internal Wear  
Sealed Track**

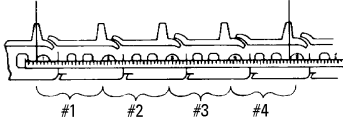

<b>Inches</b>	<b>(mm)</b>	<b>% Worn</b>
34.05	(865.0)	0
34.10	(866.0)	10
34.15	(867.5)	20
34.20	(868.5)	30
34.25	(870.0)	40
34.30	(871.0)	50
34.35	(872.5)	60
34.40	(874.0)	70
34.45	(875.0)	80
34.50	(876.5)	90
34.55	(877.5)	100
34.60	(879.0)	105
34.65	(880.0)	110
34.70	(881.5)	115
34.75	(882.5)	120

1 Wear Chart: 420



**Bushings <sup>(1)</sup>**  
**External Wear**  
**Sealed Track**  
**Enhanced SALT Track**

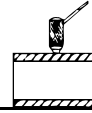
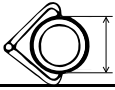

**Allowable Wear**

Caliper		Lesser	Greater	Ultrasonic	
Inches	(mm)	% Worn	% Worn	Inches	(mm)
3.04	(77.2)	0	0	0.56	(14.2)
3.03	(77.0)	6	5	0.55	(14.0)
3.02	(76.7)	12	10	0.54	(13.7)
3.01	(76.5)	18	15	0.53	(13.5)
3.00	(76.2)	24	20	0.52	(13.2)
2.99	(75.9)	30	25	0.51	(13.0)
2.98	(75.7)	36	30	0.50	(12.7)
2.97	(75.4)	42	35	0.49	(12.4)
2.96	(75.2)	48	40	0.48	(12.2)
2.95	(74.9)	54	45	0.47	(11.9)
2.94	(74.7)	60	50	0.46	(11.7)
2.93	(74.4)	64	55	0.45	(11.4)
2.92	(74.2)	67	60	0.44	(11.2)
2.91	(73.9)	70	65	0.43	(10.9)
2.90	(73.7)	73	68	0.42	(10.7)
2.89	(73.4)	76	70	0.41	(10.4)
2.88	(73.2)	79	72	0.40	(10.2)
2.87	(72.9)	82	74	0.39	(9.9)
2.86	(72.6)	85	76	0.38	(9.7)
2.85	(72.4)	88	78	0.37	(9.4)
2.84	(72.1)	91	80	0.36	(9.1)
2.83	(71.9)	94	82	0.35	(8.9)
2.82	(71.6)	97	84	0.34	(8.6)
2.81	(71.4)	100	86	0.33	(8.4)
2.80	(71.1)	103	88	0.32	(8.1)
2.79	(70.9)	106	90	0.31	(7.9)
2.78	(70.6)	109	92	0.30	(7.6)
2.77	(70.4)	112	94	0.29	(7.4)
2.76	(70.1)	115	96	0.28	(7.1)
2.75	(69.9)	118	98	0.27	(6.9)
2.74	(69.6)	121	100	0.26	(6.6)
2.73	(69.3)		102	0.25	(6.3)
2.72	(69.1)		104	0.24	(6.1)
2.71	(68.8)		106	0.23	(5.8)
2.70	(68.6)		108	0.22	(5.6)
2.69	(68.3)		110	0.21	(5.3)
2.68	(68.1)		112	0.20	(5.1)
2.67	(67.8)		114	0.19	(4.8)
2.66	(67.6)		116	0.18	(4.6)
2.65	(67.3)		118	0.17	(4.3)
2.64	(67.1)		120	0.16	(4.1)

# D7, 977, 571, 572 - 8.50 in. (215.9 mm)

**Bushings <sup>(1)</sup>  
External Wear  
Sealed Track  
Use with 8S Links**

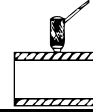

Caliper		Allowable Wear		Ultrasonic	
Inches	(mm)	Lesser % Worn	Greater % Worn	Inches	(mm)
2.83	(71.9)	0	0	0.46	(11.7)
2.82	(71.6)	9	7	0.45	(11.4)
2.81	(71.4)	18	14	0.44	(11.2)
2.80	(71.1)	27	21	0.43	(10.9)
2.79	(70.9)	36	28	0.42	(10.7)
2.78	(70.6)	45	35	0.41	(10.4)
2.77	(70.4)	54	42	0.40	(10.2)
2.76	(70.1)	63	49	0.39	(9.9)
2.75	(69.9)	72	56	0.38	(9.7)
2.74	(69.6)	81	63	0.37	(9.4)
2.73	(69.3)	88	70	0.36	(9.1)
2.72	(69.1)	92	73	0.35	(8.9)
2.71	(68.8)	96	76	0.34	(8.6)
2.70	(68.6)	100	79	0.33	(8.4)
2.69	(68.3)	104	82	0.32	(8.1)
2.68	(68.1)	108	85	0.31	(7.9)
2.67	(67.8)	112	88	0.30	(7.6)
2.66	(67.6)	116	91	0.29	(7.4)
2.65	(67.3)	120	94	0.28	(7.1)
2.64	(67.1)		97	0.27	(6.9)
2.63	(66.8)		100	0.26	(6.6)
2.62	(66.5)		103	0.25	(6.4)
2.61	(66.3)		106	0.24	(6.1)
2.60	(66.0)		109	0.23	(5.8)
2.59	(65.8)		112	0.22	(5.6)
2.58	(65.5)		115	0.21	(5.3)
2.57	(65.3)		118	0.20	(5.1)
2.56	(65.0)		121	0.19	(4.8)

**Track Shoes <sup>(1)</sup>  
Genuine and Classic  
Extreme Service**

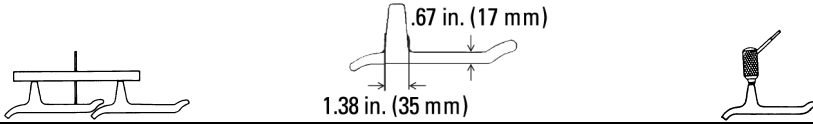

Depth Gauge		High Impact	Low/Moderate	Ultrasonic	
Inches	(mm)	% Worn	Impact % Worn	Inches	(mm)
3.20	(81.5)	0	0	3.90	(99.1)
3.10	(78.5)	6	5	3.80	(96.5)
3.00	(76.0)	12	10	3.70	(94.0)
2.90	(73.5)	18	15	3.60	(91.4)
2.80	(71.0)	24	20	3.50	(88.9)
2.70	(68.5)	30	25	3.40	(86.4)
2.60	(66.0)	36	30	3.30	(83.8)
2.50	(63.5)	42	35	3.20	(81.3)
2.40	(61.0)	48	40	3.10	(78.7)
2.30	(58.5)	54	45	3.00	(76.2)
2.20	(56.0)	60	50	2.90	(73.7)
2.10	(53.5)	66	55	2.80	(71.1)
2.00	(51.0)	72	60	2.70	(68.6)
1.90	(48.5)	78	64	2.60	(66.0)
1.80	(45.5)	84	68	2.50	(63.5)
1.70	(43.0)	90	72	2.40	(61.0)
1.60	(40.5)	95	76	2.30	(58.4)
1.50	(38.0)	100	80	2.20	(55.9)
1.40	(35.5)	105	84	2.10	(53.3)
1.30	(33.0)	110	88	2.00	(50.8)
1.20	(30.5)	115	92	1.90	(48.3)
1.10	(28.0)	120	96	1.80	(45.7)
1.00	(25.5)		100	1.70	(43.2)
0.90	(23.0)		104	1.60	(40.6)
0.80	(20.5)		108	1.50	(38.1)
0.70	(18.0)		112	1.40	(35.6)
0.60	(15.0)		116	1.30	(33.0)
0.50	(12.5)		120	1.20	(30.5)

# D7, 977, 571, 572 - 8.50 in. (215.9 mm)

## Track Shoes <sup>(1)</sup> Genuine and Classic Moderate Service

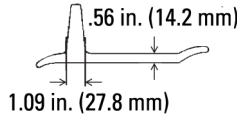
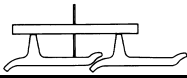

Depth Gauge		High Impact	Low/Moderate	Ultrasonic	
Inches	(mm)	% Worn	Impact % Worn	Inches	(mm)
2.90	(73.5)	0	0	3.45	(87.6)
2.80	(71.0)	8	6	3.35	(85.1)
2.70	(68.5)	16	12	3.25	(82.6)
2.60	(66.0)	23	18	3.15	(80.0)
2.50	(63.5)	30	24	3.05	(77.5)
2.40	(61.0)	37	30	2.95	(74.9)
2.30	(58.5)	44	35	2.85	(72.4)
2.20	(56.0)	51	40	2.75	(69.9)
2.10	(53.5)	58	45	2.65	(67.3)
2.00	(51.0)	65	50	2.55	(64.8)
1.90	(48.5)	72	55	2.45	(62.2)
1.80	(45.5)	79	60	2.35	(59.7)
1.70	(43.0)	86	65	2.25	(57.2)
1.60	(40.5)	93	70	2.15	(54.6)
1.50	(38.0)	100	75	2.05	(52.1)
1.40	(35.5)	107	80	1.95	(49.5)
1.30	(33.0)	114	85	1.85	(47.0)
1.20	(30.5)	121	90	1.75	(44.5)
1.10	(28.0)		95	1.65	(41.9)
1.00	(25.5)		100	1.55	(39.4)
0.90	(23.0)		105	1.45	(36.8)
0.80	(20.5)		110	1.35	(34.3)
0.70	(18.0)		115	1.25	(31.8)
0.60	(15.0)		120	1.15	(29.2)

**Track Shoes <sup>(1)</sup>  
Double Grouser**

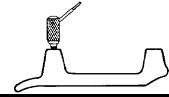
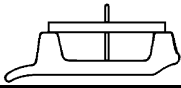
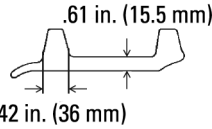

Depth Gauge		High Impact	Low/Moderate	Ultrasonic	
Inches	(mm)	% Worn	Impact % Worn	Inches	(mm)
1.95	(49.5)	0	0	2.55	(64.8)
1.90	(48.5)	5	4	2.50	(63.5)
1.85	(47.0)	10	8	2.45	(62.2)
1.80	(45.5)	15	12	2.40	(61.0)
1.75	(44.5)	20	16	2.35	(59.7)
1.70	(43.0)	24	20	2.30	(58.4)
1.65	(42.0)	28	24	2.25	(57.2)
1.60	(40.5)	32	28	2.20	(55.9)
1.55	(39.5)	36	32	2.15	(54.6)
1.50	(38.0)	40	36	2.10	(53.3)
1.45	(37.0)	44	40	2.05	(52.1)
1.40	(35.5)	48	44	2.00	(50.8)
1.35	(34.5)	52	48	1.95	(49.5)
1.30	(33.0)	56	52	1.90	(48.3)
1.25	(32.0)	60	55	1.85	(47.0)
1.20	(30.5)	64	58	1.80	(45.7)
1.15	(29.0)	68	61	1.75	(44.5)
1.10	(28.0)	72	64	1.70	(43.2)
1.05	(26.5)	76	67	1.65	(41.9)
1.00	(25.5)	80	70	1.60	(40.6)
0.95	(24.0)	84	73	1.55	(39.4)
0.90	(23.0)	88	76	1.50	(38.1)
0.85	(21.5)	92	79	1.45	(36.8)
0.80	(20.5)	96	82	1.40	(35.6)
0.75	(19.0)	100	85	1.35	(34.3)
0.70	(18.0)	104	88	1.30	(33.0)
0.65	(16.5)	108	91	1.25	(31.8)
0.60	(15.0)	112	94	1.20	(30.5)
0.55	(14.0)	116	97	1.15	(29.2)
0.50	(12.5)	120	100	1.10	(27.9)
0.45	(11.5)		103	1.05	(26.7)
0.40	(10.0)		106	1.00	(25.4)
0.35	(9.0)		109	0.95	(24.1)
0.30	(7.5)		112	0.90	(22.9)
0.25	(6.5)		115	0.85	(21.6)
0.20	(5.0)		118	0.80	(20.3)
0.15	(4.0)		121	0.75	(19.1)

**D7, 977, 571, 572 - 8.50 in. (215.9 mm)**

**Track Shoes <sup>(1)</sup>  
Classic  
Double Grouser**  
.65 in. (16.5 mm)

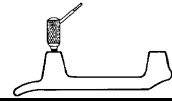
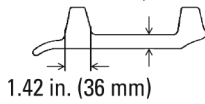
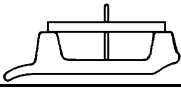

Depth Gauge		High Impact	Low/Moderate	Ultrasonic	
Inches	(mm)	% Worn	Impact % Worn	Inches	(mm)
1.45	(37.0)	0	0	2.10	(53.3)
1.40	(35.5)	8	6	2.05	(52.1)
1.35	(34.5)	16	12	2.00	(50.8)
1.30	(33.0)	23	18	1.95	(49.5)
1.25	(32.0)	30	24	1.90	(48.3)
1.20	(30.5)	37	30	1.85	(47.0)
1.15	(29.0)	44	35	1.80	(45.7)
1.10	(28.0)	51	40	1.75	(44.5)
1.05	(26.5)	58	45	1.70	(43.2)
1.00	(25.5)	65	50	1.65	(41.9)
0.95	(24.0)	72	55	1.60	(40.6)
0.90	(23.0)	79	60	1.55	(39.4)
0.85	(21.5)	86	65	1.50	(38.1)
0.80	(20.5)	93	70	1.45	(36.8)
0.75	(19.0)	100	75	1.40	(35.6)
0.70	(18.0)	107	80	1.35	(34.3)
0.65	(16.5)	114	85	1.30	(33.0)
0.60	(15.0)	121	90	1.25	(31.8)
0.55	(14.0)		95	1.20	(30.5)
0.50	(12.5)		100	1.15	(29.2)
0.45	(11.5)		105	1.10	(27.9)
0.40	(10.0)		110	1.05	(26.7)
0.35	(9.0)		115	1.00	(25.4)
0.30	(7.5)		120	0.95	(24.1)

**Track Shoes <sup>(1)</sup>  
Triple Grouser**

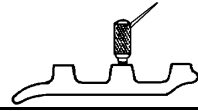
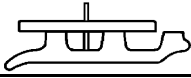
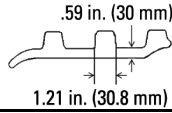

**Depth Gauge**

**Ultrasonic**

Inches	(mm)	% Worn	Inches	(mm)
1.05	(26.5)	0	1.65	(41.9)
1.00	(25.5)	10	1.60	(40.6)
0.95	(24.0)	19	1.55	(39.4)
0.90	(23.0)	28	1.50	(38.1)
0.85	(21.5)	37	1.45	(36.8)
0.80	(20.5)	46	1.40	(35.6)
0.75	(19.0)	55	1.35	(34.3)
0.70	(18.0)	64	1.30	(33.0)
0.65	(16.5)	73	1.25	(31.8)
0.60	(15.0)	82	1.20	(30.5)
0.55	(14.0)	91	1.15	(29.2)
0.50	(12.5)	100	1.10	(27.9)
0.45	(11.5)	109	1.05	(26.7)
0.40	(10.0)	118	1.00	(25.4)
0.35	(9.0)	127	0.95	(24.1)

**D7, 977, 571, 572 — 8.50 in. (215.9 mm)**

**Track Shoes <sup>(1)</sup>  
Self Cleaning**



**Depth Gauge**

<b>Inches</b>	<b>(mm)</b>	<b>% Worn</b>
4.08	(103.5)	0
4.06	(103.0)	4
4.04	(102.5)	8
4.02	(102.0)	12
4.00	(101.5)	16
3.98	(101.0)	20
3.96	(100.5)	24
3.94	(100.0)	28
3.92	(99.5)	32
3.90	(99.0)	36
3.88	(98.5)	40
3.86	(98.0)	44
3.84	(97.5)	48
3.82	(97.0)	52
3.80	(96.5)	55
3.78	(96.0)	58
3.76	(95.5)	61
3.74	(95.0)	64
3.72	(94.5)	67
3.70	(94.0)	70
3.68	(93.5)	73
3.66	(93.0)	76
3.64	(92.5)	79
3.62	(92.0)	82
3.60	(91.5)	85
3.58	(91.0)	88
3.56	(90.5)	91
3.54	(90.0)	94
3.52	(89.5)	97
3.50	(89.0)	100
3.48	(88.5)	103
3.46	(88.0)	106
3.44	(87.5)	109
3.42	(87.0)	112
3.40	(86.5)	115
3.38	(86.0)	118
3.36	(85.5)	121

1 Wear Chart: 1921



## D7, 977, 571, 572 — 8.50 in. (215.9 mm)

### Track Shoes <sup>(1)</sup> Chopper

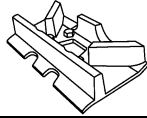

Depth Gauge			Ultrasonic	
Inches	(mm)	% Worn	Inches	(mm)
3.15	(80.0)	0	3.75	(95.3)
3.05	(77.5)	5	3.65	(92.7)
2.95	(75.0)	10	3.55	(90.2)
2.85	(72.5)	15	3.45	(87.6)
2.75	(70.0)	20	3.35	(85.1)
2.65	(67.5)	24	3.25	(82.6)
2.55	(65.0)	28	3.15	(80.0)
2.45	(62.0)	32	3.05	(77.5)
2.35	(59.5)	36	2.95	(74.9)
2.25	(57.0)	40	2.85	(72.4)
2.15	(54.5)	44	2.75	(69.9)
2.05	(52.0)	48	2.65	(67.3)
1.95	(49.5)	52	2.55	(64.8)
1.85	(47.0)	56	2.45	(62.2)
1.75	(44.5)	60	2.35	(59.7)
1.65	(42.0)	64	2.25	(57.2)
1.55	(39.5)	68	2.15	(54.6)
1.45	(37.0)	72	2.05	(52.1)
1.35	(34.5)	76	1.95	(49.5)
1.25	(31.5)	80	1.85	(47.0)
1.15	(29.0)	84	1.75	(44.5)
1.05	(26.5)	88	1.65	(41.9)
0.95	(24.0)	92	1.55	(39.4)
0.85	(21.5)	96	1.45	(36.8)
0.75	(19.0)	100	1.35	(34.3)
0.65	(16.5)	104	1.25	(31.7)
0.55	(14.0)	108	1.15	(29.2)
0.45	(11.5)	112	1.05	(26.7)
0.35	(9.0)	116	0.95	(24.1)
0.25	(6.5)	120	0.85	(21.6)

# D7, 977, 571, 572 — 8.50 in. (215.9 mm)

## Idlers <sup>(1)</sup> <sup>(2)</sup> <sup>(3)</sup> Extended Life & Classic Idlers (Has circular side plate indentations)

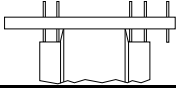

**Depth Gauge**

Inches	(mm)	% Worn
0.78	(20.0)	0
0.80	(20.5)	6
0.82	(21.0)	12
0.84	(21.5)	18
0.86	(22.0)	24
0.88	(22.5)	30
0.90	(23.0)	36
0.92	(23.5)	42
0.94	(24.0)	48
0.96	(24.5)	54
0.98	(25.0)	60
1.00	(25.5)	66
1.02	(26.0)	72
1.04	(26.5)	76
1.06	(27.0)	78
1.08	(27.5)	80
1.10	(28.0)	82
1.12	(28.5)	84
1.14	(29.0)	86
1.16	(29.5)	88
1.18	(30.0)	90
1.20	(30.5)	92
1.22	(31.0)	94
1.24	(31.5)	96
1.26	(32.0)	98
1.28	(32.5)	100
1.30	(33.0)	102
1.32	(33.5)	104
1.34	(34.0)	106
1.36	(34.5)	108
1.38	(35.0)	110
1.40	(35.5)	112
1.42	(36.0)	114
1.44	(36.5)	116
1.46	(37.0)	118
1.48	(37.5)	120

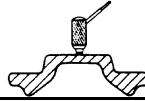

**Ultrasonic**

**Center Flange Wear**

Inches	(mm)	Inches	(mm)
0.48	(12.2)	0.00	(0.0)
0.46	(11.7)	0.02	(0.5)
0.44	(11.2)	0.04	(1.0)
0.42	(10.7)	0.06	(1.5)
0.40	(10.2)	0.08	(2.0)
0.38	(9.7)	0.10	(2.5)
0.36	(9.1)	0.12	(3.0)
0.34	(8.6)	0.14	(3.5)
0.32	(8.1)	0.16	(4.0)
0.30	(7.6)	0.18	(4.5)
0.28	(7.1)	0.20	(5.0)
0.26	(6.6)	0.22	(5.5)
0.24	(6.1)	0.24	(6.0)
0.22	(5.6)	0.26	(6.5)
0.20	(5.1)	0.28	(7.0)
0.18	(4.6)	0.30	(7.5)
0.16	(4.1)	0.32	(8.0)
0.14	(3.6)	0.34	(8.5)
0.12	(3.0)	0.36	(9.0)
0.10	(2.5)	0.38	(9.5)
0.08	(2.0)	0.40	(10.0)
0.06	(1.5)	0.42	(10.5)
0.04	(1.0)	0.44	(11.0)
0.02	(0.5)	0.46	(11.5)

**NOTE**

Ultrasonic measurement is to determine flange wear only.

- 1 Flange width is 4.02 in. (102 mm)
- 2 New tread diameter is 29.61 in. (752 mm)
- 3 Wear Chart: 4421

**Idlers <sup>(1) (2) (3)</sup>**  
**(Has no side plate indentations)**

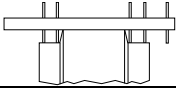

**Depth Gauge**

Inches	(mm)	% Worn
0.86	(22.0)	0
0.88	(22.5)	9
0.90	(23.0)	18
0.92	(23.5)	27
0.94	(24.0)	36
0.96	(24.5)	45
0.98	(25.0)	54
1.00	(25.5)	63
1.02	(26.0)	72
1.04	(26.5)	80
1.06	(27.0)	82
1.08	(27.5)	84
1.10	(28.0)	86
1.12	(28.5)	88
1.14	(29.0)	90
1.16	(29.5)	92
1.18	(30.0)	94
1.20	(30.5)	96
1.22	(31.0)	98
1.24	(31.5)	100
1.26	(32.0)	102
1.28	(32.5)	104
1.30	(33.0)	106
1.32	(33.5)	108
1.34	(34.0)	110
1.36	(34.5)	112
1.38	(35.0)	114
1.40	(35.5)	116
1.42	(36.0)	118
1.44	(36.5)	120

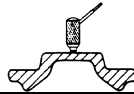

**Ultrasonic**

**Center Flange Wear**

Inches	(mm)	Inches	(mm)
0.42	(10.7)	0.00	(0.0)
0.40	(10.2)	0.02	(0.5)
0.38	(9.7)	0.04	(1.0)
0.36	(9.1)	0.06	(1.5)
0.34	(8.6)	0.08	(2.0)
0.32	(8.1)	0.10	(2.5)
0.30	(7.6)	0.12	(3.0)
0.28	(7.1)	0.14	(3.5)
0.26	(6.6)	0.16	(4.0)
0.24	(6.1)	0.18	(4.5)
0.22	(5.6)	0.20	(5.0)
0.20	(5.1)	0.22	(5.5)
0.18	(4.6)	0.24	(6.0)
0.16	(4.1)	0.26	(6.5)
0.14	(3.6)	0.28	(7.0)
0.12	(3.0)	0.30	(7.5)
0.10	(2.5)	0.32	(8.0)
0.08	(2.0)	0.34	(8.5)
0.06	(1.5)	0.36	(9.0)
0.04	(1.0)	0.38	(9.5)
0.02	(0.5)	0.40	(10.0)

**NOTE**

Ultrasonic measurement is to determine flange wear only.

- 1 Flange width is 4.00 in. (101.6 mm)
- 2 New tread diameter is 29.61 in. (752 mm)
- 3 Wear Chart: 4420

# D7, 977, 571, 572 - 8.50 in. (215.9 mm)

## Carrier Rollers <sup>(1)</sup> Use with 7T or Enhanced SALT Links

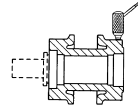
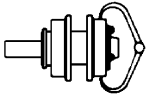

Caliper			Ultrasonic		
Inches	(mm)	% Worn	Inches	(mm)	
7.50	(190.5)	0	1.92	(48.8)	
7.42	(188.5)	8	1.88	(47.8)	
7.34	(186.5)	16	1.84	(46.7)	
7.26	(184.5)	24	1.80	(45.7)	
7.18	(182.5)	32	1.76	(44.7)	
7.10	(180.5)	40	1.72	(43.7)	
7.02	(178.5)	48	1.68	(42.7)	
6.94	(176.5)	52	1.64	(41.7)	
6.86	(174.0)	56	1.60	(40.6)	
6.78	(172.0)	60	1.56	(39.6)	
6.70	(170.0)	64	1.52	(38.6)	
6.62	(168.0)	68	1.48	(37.6)	
6.54	(166.0)	72	1.44	(36.6)	
6.46	(164.0)	76	1.40	(35.6)	
6.38	(162.0)	80	1.36	(34.5)	
6.30	(160.0)	84	1.32	(33.5)	
6.22	(158.0)	88	1.28	(32.5)	
6.14	(156.0)	92	1.24	(31.5)	
6.06	(154.0)	96	1.20	(30.5)	
5.98	(152.0)	100	1.16	(29.5)	
5.90	(150.0)	104	1.12	(28.4)	
5.82	(148.0)	108	1.08	(27.4)	
5.74	(146.0)	112	1.04	(26.4)	
5.66	(144.0)	116	1.00	(25.4)	
5.58	(141.5)	120	0.96	(24.4)	

## D7, 977, 571, 572 - 8.50 in. (215.9 mm)

**Carrier Rollers <sup>(1)</sup>**  
**Genuine and Classic**  
 Use with 8S-2589 & 90 or 188-5251 & 52 Links

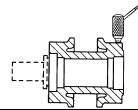
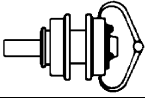

Caliper			Ultrasonic	
Inches	(mm)	% Worn	Inches	(mm)
7.50	(190.5)	0	1.92	(48.8)
7.46	(189.5)	6	1.90	(48.3)
7.42	(188.5)	12	1.88	(47.8)
7.38	(187.5)	18	1.86	(47.2)
7.34	(186.5)	24	1.84	(46.7)
7.30	(185.5)	30	1.82	(46.2)
7.26	(184.5)	36	1.80	(45.7)
7.22	(183.5)	42	1.78	(45.2)
7.18	(182.5)	48	1.76	(44.7)
7.14	(181.5)	54	1.74	(44.2)
7.10	(180.5)	60	1.72	(43.7)
7.06	(179.5)	66	1.70	(43.2)
7.02	(178.0)	72	1.68	(42.7)
6.98	(177.0)	76	1.66	(42.2)
6.94	(176.0)	80	1.64	(41.7)
6.90	(175.0)	84	1.62	(41.1)
6.86	(174.0)	88	1.60	(40.6)
6.82	(173.0)	92	1.58	(40.1)
6.78	(172.0)	96	1.56	(39.6)
6.74	(171.0)	100	1.54	(39.1)
6.70	(170.0)	104	1.52	(38.6)
6.66	(169.0)	108	1.50	(38.1)
6.62	(168.0)	112	1.48	(37.6)
6.58	(167.0)	116	1.46	(37.1)
6.54	(166.0)	120	1.44	(36.6)

# D7E - 8.50 in. (215.9 mm)

## Track Rollers <sup>(1) (2)</sup> End Collar and Standardized Rollers

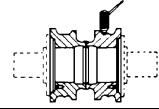
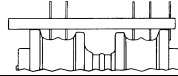
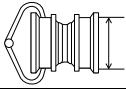

Caliper		% Worn	Depth Gauge		Ultrasonic	
Inches	(mm)		Inches	(mm)	Inches	(mm)
8.76	(222.5)	0	0.63	(16.0)	2.06	(52.3)
8.68	(220.5)	6	0.67	(17.0)	2.02	(51.3)
8.60	(218.5)	12	0.71	(18.0)	1.98	(50.3)
8.52	(216.5)	18	0.75	(19.0)	1.94	(49.3)
8.44	(214.5)	24	0.79	(20.0)	1.90	(48.3)
8.36	(212.5)	30	0.83	(21.0)	1.86	(47.2)
8.28	(210.5)	36	0.87	(22.0)	1.82	(46.2)
8.20	(208.5)	42	0.91	(23.0)	1.78	(45.2)
8.12	(206.0)	48	0.95	(24.0)	1.74	(44.2)
8.04	(204.0)	54	0.99	(25.0)	1.70	(43.2)
7.96	(202.0)	60	1.03	(26.0)	1.66	(42.2)
7.88	(200.0)	64	1.07	(27.0)	1.62	(41.1)
7.80	(198.0)	68	1.11	(28.0)	1.58	(40.1)
7.72	(196.0)	72	1.15	(29.0)	1.54	(39.1)
7.64	(194.0)	76	1.19	(30.0)	1.50	(38.1)
7.56	(192.0)	80	1.23	(31.0)	1.46	(37.1)
7.48	(190.0)	84	1.27	(32.5)	1.42	(36.1)
7.40	(188.0)	88	1.31	(33.5)	1.38	(35.1)
7.32	(186.0)	92	1.35	(34.5)	1.34	(34.0)
7.24	(184.0)	96	1.39	(35.5)	1.30	(33.0)
7.16	(182.0)	100	1.43	(36.5)	1.26	(32.0)
7.08	(180.0)	104	1.47	(37.5)	1.22	(31.0)
7.00	(178.0)	108	1.51	(38.5)	1.18	(30.0)
6.92	(176.0)	112	1.55	(39.5)	1.14	(29.0)
6.84	(173.5)	116	1.59	(40.5)	1.10	(27.9)
6.76	(171.5)	120	1.63	(41.5)	1.06	(26.9)

1 Flange diameter is 10.04 in. (255 mm)

2 Wear Chart: 5327

Track Rollers <sup>(1)</sup> <sup>(2)</sup>

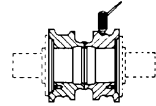
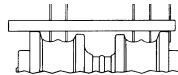
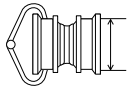

Caliper			Depth Gauge		Ultrasonic	
Inches	(mm)	% Worn	Inches	(mm)	Inches	(mm)
9.23	(234.5)	0	0.64	(16.5)	2.30	(58.4)
9.17	(233.0)	5	0.67	(17.0)	2.27	(57.7)
9.11	(231.5)	9	0.70	(18.0)	2.24	(56.9)
9.05	(230.0)	14	0.73	(18.5)	2.21	(56.1)
8.99	(228.5)	18	0.76	(19.5)	2.18	(55.4)
8.93	(227.0)	23	0.79	(20.0)	2.15	(54.6)
8.87	(225.5)	27	0.82	(21.0)	2.12	(53.8)
8.81	(224.0)	32	0.85	(21.5)	2.09	(53.1)
8.75	(222.5)	36	0.88	(22.5)	2.06	(52.3)
8.69	(220.5)	41	0.91	(23.0)	2.03	(51.6)
8.63	(219.0)	45	0.94	(24.0)	2.00	(50.8)
8.57	(217.5)	50	0.97	(24.5)	1.97	(50.0)
8.51	(216.0)	54	1.00	(25.5)	1.94	(49.3)
8.45	(214.5)	59	1.03	(26.0)	1.91	(48.5)
8.39	(213.0)	63	1.06	(27.0)	1.88	(47.8)
8.33	(211.5)	67	1.09	(27.5)	1.85	(47.0)
8.27	(210.0)	70	1.12	(28.5)	1.82	(46.2)
8.21	(208.5)	73	1.15	(29.0)	1.79	(45.5)
8.15	(207.0)	76	1.18	(30.0)	1.76	(44.7)
8.09	(205.5)	79	1.21	(30.5)	1.73	(43.9)
8.03	(204.0)	82	1.24	(31.5)	1.70	(43.2)
7.97	(202.5)	85	1.27	(32.5)	1.67	(42.4)
7.91	(201.0)	88	1.30	(33.0)	1.64	(41.7)
7.85	(199.5)	91	1.33	(34.0)	1.61	(40.9)
7.79	(198.0)	94	1.36	(34.5)	1.58	(40.1)
7.73	(196.5)	97	1.39	(35.5)	1.55	(39.4)
7.67	(195.0)	100	1.42	(36.0)	1.52	(38.6)
7.61	(193.5)	103	1.45	(37.0)	1.49	(37.8)
7.55	(192.0)	106	1.48	(37.5)	1.46	(37.1)
7.49	(190.0)	109	1.51	(38.5)	1.43	(36.3)
7.43	(188.5)	112	1.54	(39.0)	1.40	(35.6)
7.37	(187.0)	115	1.57	(40.0)	1.37	(34.8)
7.31	(185.5)	118	1.60	(40.5)	1.34	(34.0)
7.25	(184.0)	121	1.63	(41.5)	1.31	(33.3)

1 Flange diameter is 10.51 in. (267 mm)

2 Wear Chart: 5324

# D7, 977, 571, 572 - 8.50 in. (215.9 mm)

## Track Rollers <sup>(1) (2)</sup> Genuine and Classic

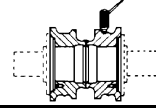
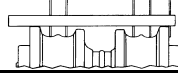
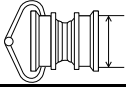

Caliper			Depth Gauge		Ultrasonic	
Inches	(mm)	% Worn	Inches	(mm)	Inches	(mm)
8.76	(222.5)	0	0.74	(19.0)	2.06	(52.3)
8.72	(221.5)	5	0.76	(19.5)	2.04	(51.8)
8.68	(220.5)	10	0.78	(20.0)	2.02	(51.3)
8.64	(219.5)	15	0.80	(20.5)	2.00	(50.8)
8.60	(218.5)	20	0.82	(21.0)	1.98	(50.3)
8.56	(217.5)	25	0.84	(21.5)	1.96	(49.8)
8.52	(216.5)	30	0.86	(22.0)	1.94	(49.3)
8.48	(215.5)	35	0.88	(22.5)	1.92	(48.8)
8.44	(214.5)	40	0.90	(23.0)	1.90	(48.3)
8.40	(213.5)	45	0.92	(23.5)	1.88	(47.8)
8.36	(212.5)	50	0.94	(24.0)	1.86	(47.2)
8.32	(211.5)	55	0.96	(24.5)	1.84	(46.7)
8.28	(210.5)	60	0.98	(25.0)	1.82	(46.2)
8.24	(209.5)	65	1.00	(25.5)	1.80	(45.7)
8.20	(208.5)	70	1.02	(26.0)	1.78	(45.2)
8.16	(207.5)	75	1.04	(26.5)	1.76	(44.7)
8.12	(206.0)	79	1.06	(27.0)	1.74	(44.2)
8.08	(205.0)	82	1.08	(27.5)	1.72	(43.7)
8.04	(204.0)	85	1.10	(28.0)	1.70	(43.2)
8.00	(203.0)	88	1.12	(28.5)	1.68	(42.7)
7.96	(202.0)	91	1.14	(29.0)	1.66	(42.2)
7.92	(201.0)	94	1.16	(29.5)	1.64	(41.7)
7.88	(200.0)	97	1.18	(30.0)	1.62	(41.1)
7.84	(199.0)	100	1.20	(30.5)	1.60	(40.6)
7.80	(198.0)	103	1.22	(31.0)	1.58	(40.1)
7.76	(197.0)	106	1.24	(31.5)	1.56	(39.6)
7.72	(196.0)	109	1.26	(32.0)	1.54	(39.1)
7.68	(195.0)	112	1.28	(32.5)	1.52	(38.6)
7.64	(194.0)	115	1.30	(33.0)	1.50	(38.1)
7.60	(193.0)	118	1.32	(33.5)	1.48	(37.6)
7.56	(192.0)	121	1.34	(34.0)	1.46	(37.1)

1 Flange diameter is 10.24 in. (260 mm)

2 Wear Chart: 5320





# D8, 583, 983 - 9.00 in. (228.6 mm)

## Track Links <sup>(1)</sup> Genuine and Classic 7S-9181 & 82 and 188-5531 & 32

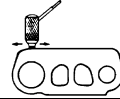
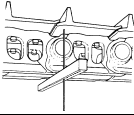

Depth Gauge			Ultrasonic	
Inches	(mm)	% Worn	Inches	(mm)
5.41	(137.5)	0	1.61	(40.9)
5.39	(137.0)	4	1.59	(40.4)
5.37	(136.5)	8	1.57	(39.9)
5.35	(136.0)	12	1.55	(39.4)
5.33	(135.5)	16	1.53	(38.9)
5.31	(135.0)	20	1.51	(38.4)
5.29	(134.5)	24	1.49	(37.8)
5.27	(134.0)	28	1.47	(37.3)
5.25	(133.5)	32	1.45	(36.8)
5.23	(133.0)	36	1.43	(36.3)
5.21	(132.5)	40	1.41	(35.8)
5.19	(132.0)	44	1.39	(35.3)
5.17	(131.5)	48	1.37	(34.8)
5.15	(131.0)	52	1.35	(34.3)
5.13	(130.5)	56	1.33	(33.8)
5.11	(130.0)	60	1.31	(33.3)
5.09	(129.5)	64	1.29	(32.8)
5.07	(129.0)	68	1.27	(32.3)
5.05	(128.5)	72	1.25	(31.8)
5.03	(128.0)	76	1.23	(31.2)
5.01	(127.5)	80	1.21	(30.7)
4.99	(126.5)	84	1.19	(30.2)
4.97	(126.0)	88	1.17	(29.7)
4.95	(125.5)	91	1.15	(29.2)
4.93	(125.0)	94	1.13	(28.7)
4.91	(124.5)	97	1.11	(28.2)
4.89	(124.0)	100	1.09	(27.7)
4.87	(123.5)	103	1.07	(27.2)
4.85	(123.0)	106	1.05	(26.7)
4.83	(122.5)	109	1.03	(26.2)
4.81	(122.0)	112	1.01	(25.7)
4.79	(121.5)	115	0.99	(25.1)
4.77	(121.0)	118	0.97	(24.6)
4.75	(120.5)	121	0.95	(24.1)

**Bushings<sup>(1)</sup>  
Genuine and Classic  
External Wear  
Sealed & Lubricated Track**

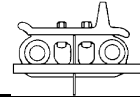
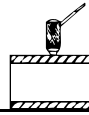

Caliper		Allowable Wear		Ultrasonic		Depth Gauge	
Inches	(mm)	Lesser % Worn	Greater % Worn	Inches	(mm)	Inches	(mm)
3.16	(80.3)	0	0	0.56	(14.2)	3.89	(98.8)
3.15	(80.0)	6	5	0.55	(14.0)	3.88	(98.6)
3.14	(79.8)	12	10	0.54	(13.7)	3.87	(98.3)
3.13	(79.5)	18	15	0.53	(13.5)	3.86	(98.0)
3.12	(79.2)	24	20	0.52	(13.2)	3.85	(97.8)
3.11	(79.0)	30	25	0.51	(13.0)	3.84	(97.5)
3.10	(78.7)	36	30	0.50	(12.7)	3.83	(97.3)
3.09	(78.5)	42	35	0.49	(12.4)	3.82	(97.0)
3.08	(78.2)	48	40	0.48	(12.2)	3.81	(96.8)
3.07	(78.0)	54	45	0.47	(11.9)	3.80	(96.5)
3.06	(77.7)	60	50	0.46	(11.7)	3.79	(96.3)
3.05	(77.5)	66	55	0.45	(11.4)	3.78	(96.0)
3.04	(77.2)	72	60	0.44	(11.2)	3.77	(95.8)
3.03	(77.0)	78	65	0.43	(10.9)	3.76	(95.5)
3.02	(76.7)	84	70	0.42	(10.7)	3.75	(95.3)
3.01	(76.5)	88	72	0.41	(10.4)	3.74	(95.0)
3.00	(76.2)	91	74	0.40	(10.2)	3.73	(94.7)
2.99	(75.9)	94	76	0.39	(9.9)	3.72	(94.5)
2.98	(75.7)	97	78	0.38	(9.7)	3.71	(94.2)
2.97	(75.4)	100	80	0.37	(9.4)	3.70	(94.0)
2.96	(75.2)	103	82	0.36	(9.1)	3.69	(93.7)
2.95	(74.9)	106	84	0.35	(8.9)	3.68	(93.5)
2.94	(74.7)	109	86	0.34	(8.6)	3.67	(93.2)
2.93	(74.4)	112	88	0.33	(8.4)	3.66	(93.0)
2.92	(74.2)	115	90	0.32	(8.1)	3.65	(92.7)
2.91	(73.9)	118	92	0.31	(7.9)	3.64	(92.5)
2.90	(73.7)	121	94	0.30	(7.6)	3.63	(92.2)
2.89	(73.4)		96	0.29	(7.4)	3.62	(91.9)
2.88	(73.2)		98	0.28	(7.1)	3.61	(91.7)
2.87	(72.9)		100	0.27	(6.9)	3.60	(91.4)
2.86	(72.6)		102	0.26	(6.6)	3.59	(91.2)
2.85	(72.4)		104	0.25	(6.3)	3.58	(90.9)
2.84	(72.1)		106	0.24	(6.1)	3.57	(90.7)
2.83	(71.9)		108	0.23	(5.8)	3.56	(90.4)
2.82	(71.6)		110	0.22	(5.6)	3.55	(90.2)
2.81	(71.4)		112	0.21	(5.3)	3.54	(89.9)
2.80	(71.1)		114	0.20	(5.1)	3.53	(89.7)
2.79	(70.9)		116	0.19	(4.8)	3.52	(89.4)
2.78	(70.6)		118	0.18	(4.6)	3.51	(89.2)
2.77	(70.4)		120	0.17	(4.3)	3.50	(88.9)

**D8, 583, 983 - 9.00 in. (228.6 mm)**

**Pins and Bushings <sup>(1)</sup>  
Internal Wear  
Sealed Track**

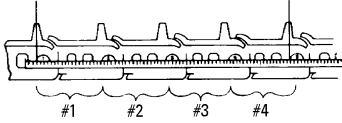

<b>Inches</b>	<b>(mm)</b>	<b>% Worn</b>
36.05	(915.5)	0
36.10	(917.0)	10
36.15	(918.0)	20
36.20	(919.5)	30
36.25	(920.5)	40
36.30	(922.0)	50
36.35	(923.5)	60
36.40	(924.5)	70
36.45	(926.0)	80
36.50	(927.0)	90
36.55	(928.5)	100
36.60	(929.5)	105
36.65	(931.0)	110
36.70	(932.0)	115
36.75	(933.5)	120

1 Wear Chart: 440

**Bushings <sup>(1)</sup>  
External Wear  
Sealed Track**

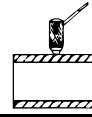

Caliper		Allowable Wear		Ultrasonic	
Inches	(mm)	Lesser % Worn	Greater % Worn	Inches	(mm)
3.04	(77.2)	0	0	0.49	(12.4)
3.03	(77.0)	10	7	0.48	(12.2)
3.02	(76.7)	20	14	0.47	(11.9)
3.01	(76.5)	30	21	0.46	(11.7)
3.00	(76.2)	40	28	0.45	(11.4)
2.99	(75.9)	50	35	0.44	(11.2)
2.98	(75.7)	60	42	0.43	(10.9)
2.97	(75.4)	70	49	0.42	(10.7)
2.96	(75.2)	80	56	0.41	(10.4)
2.95	(74.9)	90	63	0.40	(10.2)
2.94	(74.7)	95	70	0.39	(9.9)
2.93	(74.4)	100	77	0.38	(9.7)
2.92	(74.2)	105	82	0.37	(9.4)
2.91	(73.9)	110	85	0.36	(9.1)
2.90	(73.7)	115	88	0.35	(8.9)
2.89	(73.4)	120	91	0.34	(8.6)
2.88	(73.2)		94	0.33	(8.4)
2.87	(72.9)		97	0.32	(8.1)
2.86	(72.6)		100	0.31	(7.9)
2.85	(72.4)		103	0.30	(7.6)
2.84	(72.1)		106	0.29	(7.4)
2.83	(71.9)		109	0.28	(7.1)
2.82	(71.6)		112	0.27	(6.9)
2.81	(71.4)		115	0.26	(6.6)
2.80	(71.1)		118	0.25	(6.3)
2.79	(70.9)		121	0.24	(6.1)

# D8, 583, 983 - 9.00 in. (228.6 mm)

## Track Shoes <sup>(1)</sup> Super Extreme Service

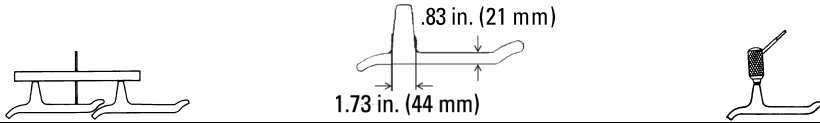

Depth Gauge		High Impact	Low/Moderate	Ultrasonic	
Inches	(mm)	% Worn	Impact % Worn	Inches	(mm)
3.70	(94.0)	0	0	4.50	(114.3)
3.60	(91.5)	5	4	4.40	(111.8)
3.50	(89.0)	10	8	4.30	(109.2)
3.40	(86.5)	15	12	4.20	(106.7)
3.30	(84.0)	20	16	4.10	(104.1)
3.20	(81.5)	25	20	4.00	(101.6)
3.10	(78.5)	30	24	3.90	(99.1)
3.00	(76.0)	35	28	3.80	(96.5)
2.90	(73.5)	40	32	3.70	(94.0)
2.80	(71.0)	45	36	3.60	(91.4)
2.70	(68.5)	50	40	3.50	(88.9)
2.60	(66.0)	55	44	3.40	(86.4)
2.50	(63.5)	60	48	3.30	(83.8)
2.40	(61.0)	64	52	3.20	(81.3)
2.30	(58.5)	68	56	3.10	(78.7)
2.20	(56.0)	72	60	3.00	(76.2)
2.10	(53.5)	76	64	2.90	(73.7)
2.00	(51.0)	80	68	2.80	(71.1)
1.90	(48.5)	84	72	2.70	(68.6)
1.80	(45.5)	88	76	2.60	(66.0)
1.70	(43.0)	92	79	2.50	(63.5)
1.60	(40.5)	96	82	2.40	(61.0)
1.50	(38.0)	100	85	2.30	(58.4)
1.40	(35.5)	104	88	2.20	(55.9)
1.30	(33.0)	108	91	2.10	(53.3)
1.20	(30.5)	112	94	2.00	(50.8)
1.10	(28.0)	116	97	1.90	(48.3)
1.00	(25.5)	120	100	1.80	(45.7)
0.90	(23.0)		103	1.70	(43.2)
0.80	(20.5)		106	1.60	(40.6)
0.70	(18.0)		109	1.50	(38.1)
0.60	(15.0)		112	1.40	(35.6)
0.50	(12.5)		115	1.30	(33.0)
0.40	(10.0)		118	1.20	(30.5)
0.30	(7.5)		121	1.10	(27.9)

**Track Shoes <sup>(1)</sup>  
Genuine and Classic  
Extreme Service**

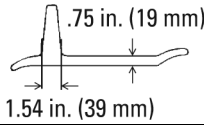
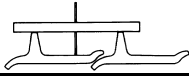

Depth Gauge		High Impact	Low/Moderate	Ultrasonic	
Inches	(mm)	% Worn	Impact % Worn	Inches	(mm)
3.10	(78.5)	0	0	3.85	(97.8)
3.00	(76.0)	7	5	3.75	(95.3)
2.90	(73.5)	14	10	3.65	(92.7)
2.80	(71.0)	21	15	3.55	(90.2)
2.70	(68.5)	28	20	3.45	(87.6)
2.60	(66.0)	34	25	3.35	(85.1)
2.50	(63.5)	40	30	3.25	(82.6)
2.40	(61.0)	46	35	3.15	(80.0)
2.30	(58.5)	52	40	3.05	(77.5)
2.20	(56.0)	58	45	2.95	(74.9)
2.10	(53.5)	64	50	2.85	(72.4)
2.00	(51.0)	70	55	2.75	(69.9)
1.90	(48.5)	76	60	2.65	(67.3)
1.80	(45.5)	82	65	2.55	(64.8)
1.70	(43.0)	88	70	2.45	(62.2)
1.60	(40.5)	94	75	2.35	(59.7)
1.50	(38.0)	100	80	2.25	(57.2)
1.40	(35.5)	106	84	2.15	(54.6)
1.30	(33.0)	112	88	2.05	(52.1)
1.20	(30.5)	118	92	1.95	(49.5)
1.10	(28.0)	124	96	1.85	(47.0)
1.00	(25.5)		100	1.75	(44.5)
0.90	(23.0)		104	1.65	(41.9)
0.80	(20.5)		108	1.55	(39.4)
0.70	(18.0)		112	1.45	(36.8)
0.60	(15.0)		116	1.35	(34.3)
0.50	(12.5)		120	1.25	(31.7)

# D8, 583, 983 - 9.00 in. (228.6 mm)

## Track Shoes <sup>(1)</sup> Genuine and Classic Moderate Service

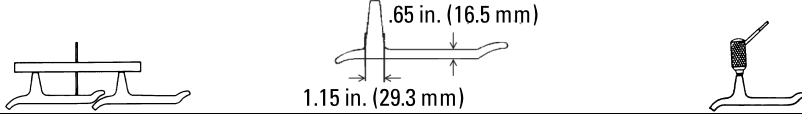

Depth Gauge		High Impact	Low/Moderate	Ultrasonic	
Inches	(mm)	% Worn	Impact % Worn	Inches	(mm)
3.00	(76.0)	0	0	3.65	(92.7)
2.90	(73.5)	7	5	3.55	(90.2)
2.80	(71.0)	14	10	3.45	(87.6)
2.70	(68.5)	21	15	3.35	(85.1)
2.60	(66.0)	28	20	3.25	(82.6)
2.50	(63.5)	35	25	3.15	(80.0)
2.40	(61.0)	42	30	3.05	(77.5)
2.30	(58.5)	49	35	2.95	(74.9)
2.20	(56.0)	56	40	2.85	(72.4)
2.10	(53.5)	63	45	2.75	(69.9)
2.00	(51.0)	70	50	2.65	(67.3)
1.90	(48.5)	76	55	2.55	(64.8)
1.80	(45.5)	82	60	2.45	(62.2)
1.70	(43.0)	88	65	2.35	(59.7)
1.60	(40.5)	94	70	2.25	(57.2)
1.50	(38.0)	100	75	2.15	(54.6)
1.40	(35.5)	106	80	2.05	(52.1)
1.30	(33.0)	112	85	1.95	(49.5)
1.20	(30.5)	118	90	1.85	(47.0)
1.10	(28.0)	124	95	1.75	(44.5)
1.00	(25.5)		100	1.65	(41.9)
0.90	(23.0)		104	1.55	(39.4)
0.80	(20.5)		108	1.45	(36.8)
0.70	(18.0)		112	1.35	(34.3)
0.60	(15.0)		116	1.25	(31.7)
0.50	(12.5)		120	1.15	(29.2)



**Track Shoes <sup>(1)</sup>  
Double Grouser**  
.75 in. (19 mm)

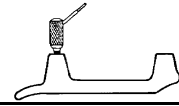
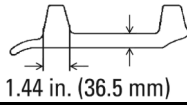
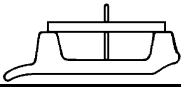

Depth Gauge		High Impact	Low/Moderate	Ultrasonic	
Inches	(mm)	% Worn	Impact % Worn	Inches	(mm)
1.75	(44.5)	0	0	2.50	(63.5)
1.70	(43.0)	5	4	2.45	(62.2)
1.65	(42.0)	10	8	2.40	(61.0)
1.60	(40.5)	15	12	2.35	(59.7)
1.55	(39.5)	20	16	2.30	(58.4)
1.50	(38.0)	25	20	2.25	(57.2)
1.45	(37.0)	30	24	2.20	(55.9)
1.40	(35.5)	35	28	2.15	(54.6)
1.35	(34.5)	40	32	2.10	(53.3)
1.30	(33.0)	45	36	2.05	(52.1)
1.25	(32.0)	50	40	2.00	(50.8)
1.20	(30.5)	55	44	1.95	(49.5)
1.15	(29.0)	60	48	1.90	(48.3)
1.10	(28.0)	65	52	1.85	(47.0)
1.05	(26.5)	70	56	1.80	(45.7)
1.00	(25.5)	75	60	1.75	(44.5)
0.95	(24.0)	80	64	1.70	(43.2)
0.90	(23.0)	85	68	1.65	(41.9)
0.85	(21.5)	90	72	1.60	(40.6)
0.80	(20.5)	95	76	1.55	(39.4)
0.75	(19.0)	100	80	1.50	(38.1)
0.70	(18.0)	105	84	1.45	(36.8)
0.65	(16.5)	110	88	1.40	(35.6)
0.60	(15.0)	115	92	1.35	(34.3)
0.55	(14.0)	120	96	1.30	(33.0)
0.50	(12.5)		100	1.25	(31.8)
0.45	(11.5)		104	1.20	(30.5)
0.40	(10.0)		108	1.15	(29.2)
0.35	(9.0)		112	1.10	(27.9)
0.30	(7.5)		116	1.05	(26.7)
0.25	(6.5)		120	1.00	(25.4)

# D8, 583, 983 - 9.00 in. (228.6 mm)

## Idlers <sup>(1)</sup> <sup>(2)</sup> <sup>(3)</sup> Genuine and Classic

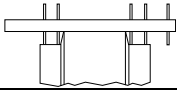

**Depth Gauge**

Inches	(mm)	% Worn
0.94	(24.0)	0
0.96	(24.5)	9
0.98	(25.0)	18
1.00	(25.5)	27
1.02	(26.0)	36
1.04	(26.5)	45
1.06	(27.0)	54
1.08	(27.5)	63
1.10	(28.0)	72
1.12	(28.5)	80
1.14	(29.0)	82
1.16	(29.5)	84
1.18	(30.0)	86
1.20	(30.5)	88
1.22	(31.0)	90
1.24	(31.5)	92
1.26	(32.0)	94
1.28	(32.5)	96
1.30	(33.0)	98
1.32	(33.5)	100
1.34	(34.0)	102
1.36	(34.5)	104
1.38	(35.0)	106
1.40	(35.5)	108
1.42	(36.0)	110
1.44	(36.5)	112
1.46	(37.0)	114
1.48	(37.5)	116
1.50	(38.0)	118
1.52	(38.5)	120



**Ultrasonic**

**Center Flange Wear**

Inches	(mm)	Inches	(mm)
0.48	(12.2)	0.00	(0.0)
0.46	(11.7)	0.02	(0.5)
0.44	(11.2)	0.04	(1.0)
0.42	(10.7)	0.06	(1.5)
0.40	(10.2)	0.08	(2.0)
0.38	(9.7)	0.10	(2.5)
0.36	(9.1)	0.12	(3.0)
0.34	(8.6)	0.14	(3.5)
0.32	(8.1)	0.16	(4.0)
0.30	(7.6)	0.18	(4.5)
0.28	(7.1)	0.20	(5.0)
0.26	(6.6)	0.22	(5.5)
0.24	(6.1)	0.24	(6.0)
0.22	(5.6)	0.26	(6.5)
0.20	(5.1)	0.28	(7.0)
0.18	(4.6)	0.30	(7.5)
0.16	(4.1)	0.32	(8.0)
0.14	(3.6)	0.34	(8.5)
0.12	(3.0)	0.36	(9.0)
0.10	(2.5)	0.38	(9.5)
0.08	(2.0)	0.40	(10.0)
0.06	(1.5)	0.42	(10.5)
0.04	(1.0)	0.44	(11.0)
0.02	(0.5)	0.46	(11.5)

### NOTE

Ultrasonic measurement is to determine flange wear only.

- 1 Flange width is 4.75 in. (120.7 mm)
- 2 New tread diameter is 32.00 in. (812.8 mm)
- 3 Wear Chart: 4440

**Carrier Rollers <sup>(1)</sup>  
Genuine and Classic**

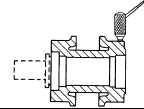
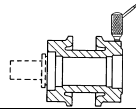
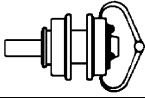

Caliper			Ultrasonic Three end cap bolts		Ultrasonic Four end cap bolts	
Inches	(mm)	% Worn	Inches	(mm)	Inches	(mm)
7.50	(190.5)	0	1.92	(48.8)	1.44	(36.5)
7.46	(189.5)	5	1.90	(48.3)	1.42	(35.9)
7.42	(188.5)	10	1.88	(47.8)	1.40	(35.4)
7.38	(187.5)	15	1.86	(47.2)	1.38	(34.9)
7.34	(186.5)	20	1.84	(46.7)	1.36	(34.4)
7.30	(185.5)	25	1.82	(46.2)	1.34	(33.9)
7.26	(184.5)	30	1.80	(45.7)	1.32	(33.4)
7.22	(183.5)	35	1.78	(45.2)	1.30	(32.9)
7.18	(182.5)	40	1.76	(44.7)	1.28	(32.4)
7.14	(181.5)	45	1.74	(44.2)	1.26	(31.9)
7.10	(180.5)	50	1.72	(43.7)	1.24	(31.4)
7.06	(179.5)	55	1.70	(43.2)	1.22	(30.9)
7.02	(178.5)	60	1.68	(42.7)	1.20	(30.4)
6.98	(177.5)	65	1.66	(42.2)	1.18	(29.8)
6.94	(176.5)	70	1.64	(41.7)	1.16	(29.3)
6.90	(175.5)	75	1.62	(41.1)	1.14	(28.8)
6.86	(174.0)	80	1.60	(40.6)	1.12	(28.3)
6.82	(173.0)	85	1.58	(40.1)	1.10	(27.8)
6.78	(172.0)	90	1.56	(39.6)	1.08	(27.3)
6.74	(171.0)	95	1.54	(39.1)	1.06	(26.8)
6.70	(170.0)	100	1.52	(38.6)	1.04	(26.3)
6.66	(169.0)	103	1.50	(38.1)	1.02	(25.8)
6.62	(168.0)	106	1.48	(37.6)	1.00	(25.3)
6.58	(167.0)	109	1.46	(37.1)	0.98	(24.8)
6.54	(166.0)	112	1.44	(36.6)	0.96	(24.3)
6.50	(165.0)	115	1.42	(36.1)	0.94	(23.8)
6.46	(164.0)	118	1.40	(35.6)	0.92	(23.2)
6.42	(163.0)	121	1.38	(35.1)	0.90	(22.7)

# D8, 583, 983 - 9.00 in. (228.6 mm)

**Track Rollers <sup>(1) (2)</sup>  
Genuine and Classic  
Do not use for 983**

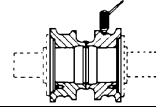
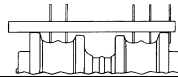
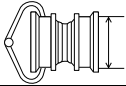

Caliper			Depth Gauge		Ultrasonic	
Inches	(mm)	% Worn	Inches	(mm)	Inches	(mm)
10.02	(254.5)	0	0.86	(22.0)	2.38	(60.5)
9.98	(253.5)	5	0.88	(22.5)	2.36	(59.9)
9.94	(252.5)	10	0.90	(23.0)	2.34	(59.4)
9.90	(251.5)	15	0.92	(23.5)	2.32	(58.9)
9.86	(250.5)	20	0.94	(24.0)	2.30	(58.4)
9.82	(249.5)	25	0.96	(24.5)	2.28	(57.9)
9.78	(249.5)	30	0.98	(25.0)	2.26	(57.4)
9.74	(247.5)	35	1.00	(25.5)	2.24	(56.9)
9.70	(246.5)	40	1.02	(26.0)	2.22	(56.4)
9.66	(245.5)	45	1.04	(26.5)	2.20	(55.9)
9.62	(244.5)	50	1.06	(27.0)	2.18	(55.4)
9.58	(243.5)	55	1.08	(27.5)	2.16	(54.9)
9.54	(242.5)	58	1.10	(28.0)	2.14	(54.4)
9.50	(241.5)	61	1.12	(28.5)	2.12	(53.8)
9.46	(240.5)	64	1.14	(29.0)	2.10	(53.3)
9.42	(239.5)	67	1.16	(29.5)	2.08	(52.8)
9.38	(238.5)	70	1.18	(30.0)	2.06	(52.3)
9.34	(237.0)	73	1.20	(30.5)	2.04	(51.8)
9.30	(236.0)	76	1.22	(31.0)	2.02	(51.3)
9.26	(235.0)	79	1.24	(31.5)	2.00	(50.8)
9.22	(234.0)	82	1.26	(32.0)	1.98	(50.3)
9.18	(233.0)	85	1.28	(32.5)	1.96	(49.8)
9.14	(232.0)	88	1.30	(33.0)	1.94	(49.3)
9.10	(231.0)	91	1.32	(33.5)	1.92	(48.8)
9.06	(230.0)	94	1.34	(34.0)	1.90	(48.3)
9.02	(229.0)	97	1.36	(34.5)	1.88	(47.8)
8.98	(228.0)	100	1.38	(35.0)	1.86	(47.2)
8.94	(227.0)	103	1.40	(35.5)	1.84	(46.7)
8.90	(226.0)	106	1.42	(36.0)	1.82	(46.2)
8.86	(225.0)	109	1.44	(36.5)	1.80	(45.7)
8.82	(224.0)	112	1.46	(37.0)	1.78	(45.2)
8.78	(223.0)	115	1.48	(37.5)	1.76	(44.7)
8.74	(222.0)	118	1.50	(38.0)	1.74	(44.2)
8.70	(221.0)	121	1.52	(38.5)	1.72	(43.7)

1 Flange diameter is 11.75 in. (298.5 mm)

2 Wear Chart: 5341

Track Rollers <sup>(1) (2)</sup>  
Use for 983

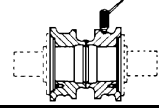
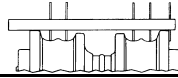
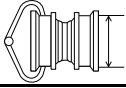

Caliper			Depth Gauge		Ultrasonic	
Inches	(mm)	% Worn	Inches	(mm)	Inches	(mm)
9.56	(243.0)	0	0.87	(22.0)	2.40	(61.0)
9.52	(242.0)	5	0.89	(22.5)	2.38	(60.5)
9.48	(241.0)	10	0.91	(23.0)	2.36	(59.9)
9.44	(240.0)	15	0.93	(23.5)	2.34	(59.4)
9.40	(239.0)	20	0.95	(24.0)	2.32	(58.9)
9.36	(237.5)	25	0.97	(24.5)	2.30	(58.4)
9.32	(236.5)	30	0.99	(25.0)	2.28	(57.9)
9.28	(235.5)	35	1.01	(25.5)	2.26	(57.4)
9.24	(234.5)	40	1.03	(26.0)	2.24	(56.9)
9.20	(233.5)	45	1.05	(26.5)	2.22	(56.4)
9.16	(232.5)	50	1.07	(27.0)	2.20	(55.9)
9.12	(231.5)	55	1.09	(27.5)	2.18	(55.4)
9.08	(230.5)	60	1.11	(28.0)	2.16	(54.9)
9.04	(229.5)	64	1.13	(28.5)	2.14	(54.4)
9.00	(228.5)	67	1.15	(29.0)	2.12	(53.8)
8.96	(227.5)	70	1.17	(29.5)	2.10	(53.3)
8.92	(226.5)	73	1.19	(30.0)	2.08	(52.8)
8.88	(225.5)	76	1.21	(30.5)	2.06	(52.3)
8.84	(224.5)	79	1.23	(31.0)	2.04	(51.8)
8.80	(223.5)	82	1.25	(32.0)	2.02	(51.3)
8.76	(222.5)	85	1.27	(32.5)	2.00	(50.8)
8.72	(221.5)	88	1.29	(33.0)	1.98	(50.3)
8.68	(220.5)	91	1.31	(33.5)	1.96	(49.8)
8.64	(219.5)	94	1.33	(34.0)	1.94	(49.3)
8.60	(218.5)	97	1.35	(34.5)	1.92	(48.8)
8.56	(217.5)	100	1.37	(35.0)	1.90	(48.3)
8.52	(216.5)	103	1.39	(35.5)	1.88	(47.8)
8.48	(215.5)	106	1.41	(36.0)	1.86	(47.2)
8.44	(214.5)	109	1.43	(36.5)	1.84	(46.7)
8.40	(213.5)	112	1.45	(37.0)	1.82	(46.2)
8.36	(212.5)	115	1.47	(37.5)	1.80	(45.7)
8.32	(211.5)	118	1.49	(38.0)	1.78	(45.2)
8.28	(210.5)	121	1.51	(38.5)	1.76	(44.7)

1 Flange diameter is 11.31 in. (287.3 mm)  
2 Wear Chart: 5340

# D9, 594 - 10.25 in. (260.4 mm)

Track Links <sup>(1)</sup>  
 8E-4055 & 56  
 9S-1927 & 28

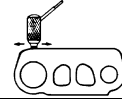
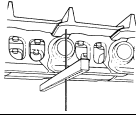

Depth Gauge			Ultrasonic	
Inches	(mm)	% Worn	Inches	(mm)
6.12	(155.5)	0	1.56	(39.6)
6.10	(155.0)	4	1.54	(39.1)
6.08	(154.5)	8	1.52	(38.6)
6.06	(154.0)	12	1.50	(38.1)
6.04	(153.5)	16	1.48	(37.6)
6.02	(153.0)	20	1.46	(37.1)
6.00	(152.5)	24	1.44	(36.6)
5.98	(152.0)	28	1.42	(36.1)
5.96	(151.5)	32	1.40	(35.6)
5.94	(151.0)	36	1.38	(35.1)
5.92	(150.5)	40	1.36	(34.5)
5.90	(150.0)	44	1.34	(34.0)
5.88	(149.5)	48	1.32	(33.5)
5.86	(149.0)	52	1.30	(33.0)
5.84	(148.5)	56	1.28	(32.5)
5.82	(148.0)	60	1.26	(32.0)
5.80	(147.5)	64	1.24	(31.5)
5.78	(147.0)	68	1.22	(31.0)
5.76	(146.5)	72	1.20	(30.5)
5.74	(146.0)	76	1.18	(30.0)
5.72	(145.5)	80	1.16	(29.5)
5.70	(145.0)	84	1.14	(29.0)
5.68	(144.5)	88	1.12	(28.4)
5.66	(144.0)	92	1.10	(27.9)
5.64	(143.5)	96	1.08	(27.4)
5.62	(142.5)	100	1.06	(26.9)
5.60	(142.0)	103	1.04	(26.4)
5.58	(141.5)	106	1.02	(25.9)
5.56	(141.0)	109	1.00	(25.4)
5.54	(140.5)	112	0.98	(24.9)
5.52	(140.0)	115	0.96	(24.4)
5.50	(139.5)	118	0.94	(23.9)
5.48	(139.0)	121	0.92	(23.4)

**Bushings (1)  
External Wear  
Sealed & Lubricated Track**

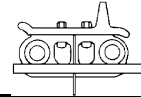
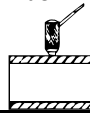

**Allowable Wear**

Caliper		Lesser		Greater		Ultrasonic		Depth Gauge	
Inches	(mm)	% Worn	% Worn	Inches	(mm)	Inches	(mm)	Inches	(mm)
3.49	(88.6)	0	0	0.60	(15.2)	4.62	(117.5)		
3.48	(88.4)	6	5	0.59	(15.0)	4.61	(117.2)		
3.47	(88.1)	12	10	0.58	(14.7)	4.60	(116.9)		
3.46	(87.9)	18	15	0.57	(14.5)	4.59	(116.7)		
3.45	(87.6)	24	20	0.56	(14.2)	4.58	(116.4)		
3.44	(87.4)	30	25	0.55	(14.0)	4.57	(116.2)		
3.43	(87.1)	36	30	0.54	(13.7)	4.56	(115.9)		
3.42	(86.9)	42	35	0.53	(13.5)	4.55	(115.7)		
3.41	(86.6)	48	40	0.52	(13.2)	4.54	(115.4)		
3.40	(86.4)	54	45	0.51	(13.0)	4.53	(115.2)		
3.39	(86.1)	60	50	0.50	(12.7)	4.52	(114.9)		
3.38	(85.9)	66	55	0.49	(12.4)	4.51	(114.7)		
3.37	(85.6)	72	60	0.48	(12.2)	4.50	(114.4)		
3.36	(85.3)	78	65	0.47	(11.9)	4.49	(114.1)		
3.35	(85.1)	84	70	0.46	(11.7)	4.48	(113.9)		
3.34	(84.8)	88	72	0.45	(11.4)	4.47	(113.6)		
3.33	(84.6)	91	74	0.44	(11.2)	4.46	(113.4)		
3.32	(84.3)	94	76	0.43	(10.9)	4.45	(113.1)		
3.31	(84.1)	97	78	0.42	(10.7)	4.44	(112.9)		
3.30	(83.8)	100	80	0.41	(10.4)	4.43	(112.6)		
3.29	(83.6)	103	82	0.40	(10.2)	4.42	(112.4)		
3.28	(83.3)	106	84	0.39	(9.9)	4.41	(112.1)		
3.27	(83.1)	109	86	0.38	(9.7)	4.40	(111.9)		
3.26	(82.8)	112	88	0.37	(9.4)	4.39	(111.6)		
3.25	(82.6)	115	90	0.36	(9.1)	4.38	(111.4)		
3.24	(82.3)	118	92	0.35	(8.9)	4.37	(111.1)		
3.23	(82.0)	121	94	0.34	(8.6)	4.36	(110.8)		
3.22	(81.8)		96	0.33	(8.4)	4.35	(110.6)		
3.21	(81.5)		98	0.32	(8.1)	4.34	(110.3)		
3.20	(81.3)		100	0.31	(7.9)	4.33	(110.1)		
3.19	(81.0)		102	0.30	(7.6)	4.32	(109.8)		
3.18	(80.8)		104	0.29	(7.4)	4.31	(109.6)		
3.17	(80.5)		106	0.28	(7.1)	4.30	(109.3)		
3.16	(80.3)		108	0.27	(6.9)	4.29	(109.1)		
3.15	(80.0)		110	0.26	(6.6)	4.28	(108.8)		
3.14	(79.8)		112	0.25	(6.3)	4.27	(108.6)		
3.13	(79.5)		114	0.24	(6.1)	4.26	(108.3)		
3.12	(79.2)		116	0.23	(5.8)	4.25	(108.1)		
3.11	(79.0)		118	0.22	(5.6)	4.24	(107.8)		
3.10	(78.7)		120	0.21	(5.3)	4.23	(107.5)		

**D9, 594 - 10.25 in. (260.4 mm)**

**Pins and Bushings <sup>(1)</sup>  
Internal Wear  
Sealed Track**

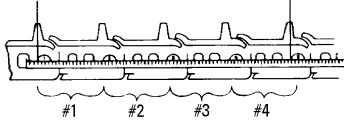

<b>Inches</b>	<b>(mm)</b>	<b>% Worn</b>
41.05	(1042.5)	0
41.10	(1044.0)	10
41.15	(1045.0)	20
41.20	(1046.5)	30
41.25	(1048.0)	40
41.30	(1049.0)	50
41.35	(1050.5)	60
41.40	(1051.5)	70
41.45	(1053.0)	80
41.50	(1054.0)	90
41.55	(1055.5)	100
41.60	(1056.5)	105
41.65	(1058.0)	110
41.70	(1059.0)	115
41.75	(1060.5)	120

1 Wear Chart: 480



**Bushings <sup>(1)</sup>  
External Wear  
Sealed Track**

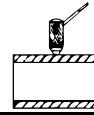

Caliper		Allowable Wear		Ultrasonic	
Inches	(mm)	Lesser % Worn	Greater % Worn	Inches	(mm)
3.39	(86.2)	0	0	0.55	(14.0)
3.38	(86.0)	9	7	0.54	(13.7)
3.37	(85.7)	18	14	0.53	(13.5)
3.36	(85.5)	27	21	0.52	(13.2)
3.35	(85.2)	36	28	0.51	(13.0)
3.34	(85.0)	45	35	0.50	(12.7)
3.33	(84.7)	54	42	0.49	(12.4)
3.32	(84.4)	63	49	0.48	(12.2)
3.31	(84.2)	72	56	0.47	(11.9)
3.30	(83.9)	81	63	0.46	(11.7)
3.29	(83.7)	88	70	0.45	(11.4)
3.28	(83.4)	92	73	0.44	(11.2)
3.27	(83.2)	96	76	0.43	(10.9)
3.26	(82.9)	100	79	0.42	(10.7)
3.25	(82.7)	104	82	0.41	(10.4)
3.24	(82.4)	108	85	0.40	(10.2)
3.23	(82.2)	112	88	0.39	(9.9)
3.22	(81.9)	116	91	0.38	(9.7)
3.21	(81.6)	120	94	0.37	(9.4)
3.20	(81.4)		97	0.36	(9.1)
3.19	(81.1)		100	0.35	(8.9)
3.18	(80.9)		103	0.34	(8.6)
3.17	(80.6)		106	0.33	(8.4)
3.16	(80.4)		109	0.32	(8.1)
3.15	(80.1)		112	0.31	(7.9)
3.14	(79.9)		115	0.30	(7.6)
3.13	(79.6)		118	0.29	(7.4)
3.12	(79.4)		121	0.28	(7.1)

# D9, 594 - 10.25 in. (260.4 mm)

## Track Shoes <sup>(1)</sup> Super Extreme Service

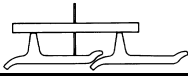

Depth Gauge		High Impact	Low/Moderate	Ultrasonic	
Inches	(mm)	% Worn	Impact % Worn	Inches	(mm)
4.00	(101.5)	0	0	4.85	(123.2)
3.90	(99.0)	4	4	4.75	(120.7)
3.80	(96.5)	8	8	4.65	(118.1)
3.70	(94.0)	12	12	4.55	(115.6)
3.60	(91.5)	16	16	4.45	(113.0)
3.50	(89.0)	20	20	4.35	(110.5)
3.40	(86.5)	24	24	4.25	(108.0)
3.30	(84.0)	28	28	4.15	(105.4)
3.20	(81.5)	32	32	4.05	(102.9)
3.10	(78.5)	36	36	3.95	(100.3)
3.00	(76.0)	40	40	3.85	(97.8)
2.90	(73.5)	44	43	3.75	(95.3)
2.80	(71.0)	48	46	3.65	(92.7)
2.70	(68.5)	52	49	3.55	(90.2)
2.60	(66.0)	56	52	3.45	(87.6)
2.50	(63.5)	60	55	3.35	(85.1)
2.40	(61.0)	64	58	3.25	(82.6)
2.30	(58.5)	68	61	3.15	(80.0)
2.20	(56.0)	72	64	3.05	(77.5)
2.10	(53.5)	76	67	2.95	(74.9)
2.00	(51.0)	80	70	2.85	(72.4)
1.90	(48.5)	84	73	2.75	(69.9)
1.80	(45.5)	88	76	2.65	(67.3)
1.70	(43.0)	92	79	2.55	(64.8)
1.60	(40.5)	96	82	2.45	(62.2)
1.50	(38.0)	100	85	2.35	(59.7)
1.40	(35.5)	104	88	2.25	(57.2)
1.30	(33.0)	108	91	2.15	(54.6)
1.20	(30.5)	112	94	2.02	(52.1)
1.10	(28.0)	116	97	1.95	(49.5)
1.00	(25.5)	120	100	1.85	(47.0)
0.90	(23.0)		103	1.75	(44.5)
0.80	(20.5)		106	1.65	(41.9)
0.70	(18.0)		109	1.55	(39.4)
0.60	(15.0)		112	1.45	(36.8)
0.50	(12.5)		115	1.35	(34.3)
0.40	(10.0)		118	1.25	(31.8)
0.30	(7.5)		121	1.15	(29.2)

**Track Shoes <sup>(1)</sup>  
Extreme Service**



Depth Gauge		High Impact	Low/Moderate	Ultrasonic	
Inches	(mm)	% Worn	Impact % Worn	Inches	(mm)
3.70	(94.0)	0	0	4.50	(114.3)
3.60	(91.5)	5	4	4.40	(111.8)
3.50	(89.0)	10	8	4.30	(109.2)
3.40	(86.5)	15	12	4.20	(106.7)
3.30	(84.0)	20	16	4.10	(104.1)
3.20	(81.5)	25	20	4.00	(101.6)
3.10	(78.5)	30	24	3.90	(99.1)
3.00	(76.0)	35	28	3.80	(96.5)
2.90	(73.5)	40	32	3.70	(94.0)
2.80	(71.0)	45	36	3.60	(91.4)
2.70	(68.5)	50	40	3.50	(88.9)
2.60	(66.0)	55	44	3.40	(86.4)
2.50	(63.5)	60	48	3.30	(83.8)
2.40	(61.0)	64	52	3.20	(81.3)
2.30	(58.5)	68	56	3.10	(78.7)
2.20	(56.0)	72	60	3.00	(76.2)
2.10	(53.5)	76	64	2.90	(73.7)
2.00	(51.0)	80	68	2.80	(71.1)
1.90	(48.5)	84	72	2.70	(68.6)
1.80	(45.5)	88	76	2.60	(66.0)
1.70	(43.0)	92	79	2.50	(63.5)
1.60	(40.5)	96	82	2.40	(61.0)
1.50	(38.0)	100	85	2.30	(58.4)
1.40	(35.5)	104	88	2.20	(55.9)
1.30	(33.0)	108	91	2.10	(53.3)
1.20	(30.5)	112	94	2.00	(50.8)
1.10	(28.0)	116	97	1.90	(48.3)
1.00	(25.5)	120	100	1.80	(45.7)
0.90	(23.0)		103	1.70	(43.2)
0.80	(20.5)		106	1.60	(40.6)
0.70	(18.0)		109	1.50	(38.1)
0.60	(15.0)		112	1.40	(35.6)
0.50	(12.5)		115	1.30	(33.0)
0.40	(10.0)		118	1.20	(30.5)
0.30	(7.5)		121	1.10	(27.9)

# D9, 594 - 10.25 in. (260.4 mm)

## Track Shoes <sup>(1)</sup> Moderate Service

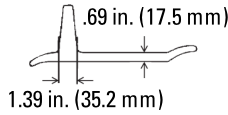
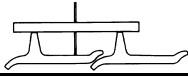

Depth Gauge		High Impact	Low/Moderate	Ultrasonic	
Inches	(mm)	% Worn	Impact % Worn	Inches	(mm)
3.40	(86.5)	0	0	4.10	(104.1)
3.30	(84.0)	6	5	4.00	(101.6)
3.20	(81.5)	12	10	3.90	(99.1)
3.10	(78.5)	18	15	3.80	(96.5)
3.00	(76.0)	24	20	3.70	(94.0)
2.90	(73.5)	30	24	3.60	(91.4)
2.80	(71.0)	35	28	3.50	(88.9)
2.70	(68.5)	40	32	3.40	(86.4)
2.60	(66.0)	45	36	3.30	(83.8)
2.50	(63.5)	50	40	3.20	(81.3)
2.40	(61.0)	55	44	3.10	(78.7)
2.30	(58.5)	60	48	3.00	(76.2)
2.20	(56.0)	65	52	2.90	(73.7)
2.10	(53.5)	70	56	2.80	(71.1)
2.00	(51.0)	75	60	2.70	(68.6)
1.90	(48.5)	80	64	2.60	(66.0)
1.80	(45.5)	85	68	2.50	(63.5)
1.70	(43.0)	90	72	2.40	(61.0)
1.60	(40.5)	95	76	2.30	(58.4)
1.50	(38.0)	100	80	2.20	(55.9)
1.40	(35.5)	105	84	2.10	(53.3)
1.30	(33.0)	110	88	2.00	(50.8)
1.20	(30.5)	115	92	1.90	(48.3)
1.10	(28.0)	120	96	1.80	(45.7)
1.00	(25.5)		100	1.70	(43.2)
0.90	(23.0)		104	1.60	(40.6)
0.80	(20.5)		108	1.50	(38.1)
0.70	(18.0)		112	1.40	(35.6)
0.60	(15.0)		116	1.30	(33.0)
0.50	(12.5)		120	1.20	(30.5)

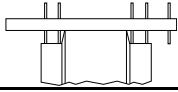

Idlers (1) (2) (3)

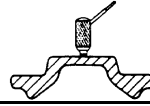

Depth Gauge		
Inches	(mm)	% Worn
0.88	(22.5)	0
0.90	(23.0)	9
0.92	(23.5)	18
0.94	(24.0)	27
0.96	(24.5)	36
0.98	(25.0)	45
1.00	(25.5)	54
1.02	(26.0)	63
1.04	(26.5)	72
1.06	(27.0)	80
1.08	(27.5)	82
1.10	(28.0)	84
1.12	(28.5)	86
1.14	(29.0)	88
1.16	(29.5)	90
1.18	(30.0)	92
1.20	(30.5)	94
1.22	(31.0)	96
1.24	(31.5)	98
1.26	(32.0)	100
1.28	(32.5)	102
1.30	(33.0)	104
1.32	(33.5)	106
1.34	(34.0)	108
1.36	(34.5)	110
1.38	(35.0)	112
1.40	(35.5)	114
1.42	(36.0)	116
1.44	(36.5)	118
1.46	(37.0)	120

Ultrasonic		Center Flange Wear	
Inches	(mm)	Inches	(mm)
0.48	(12.2)	0.00	(0.0)
0.46	(11.7)	0.02	(0.5)
0.44	(11.2)	0.04	(1.0)
0.42	(10.7)	0.06	(1.5)
0.40	(10.2)	0.08	(2.0)
0.38	(9.7)	0.10	(2.5)
0.36	(9.1)	0.12	(3.0)
0.34	(8.6)	0.14	(3.5)
0.32	(8.1)	0.16	(4.0)
0.30	(7.6)	0.18	(4.5)
0.28	(7.1)	0.20	(5.0)
0.26	(6.6)	0.22	(5.5)
0.24	(6.1)	0.24	(6.0)
0.22	(5.6)	0.26	(6.5)
0.20	(5.1)	0.28	(7.0)
0.18	(4.6)	0.30	(7.5)
0.16	(4.1)	0.32	(8.0)
0.14	(3.6)	0.34	(8.5)
0.12	(3.0)	0.36	(9.0)
0.10	(2.5)	0.38	(9.5)
0.08	(2.0)	0.40	(10.0)
0.06	(1.5)	0.42	(10.5)
0.04	(1.0)	0.44	(11.0)
0.02	(0.5)	0.46	(11.5)

**NOTE**

Ultrasonic measurement is to determine flange wear only.

- 1 Flange width is 5.09 in. (129.5 mm)
- 2 New tread diameter is 35.00 in. (889.0 mm)
- 3 Wear Chart: 4481

# D9, 594 - 10.25 in. (260.4 mm)

## Carrier Rollers <sup>(1)</sup>

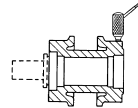
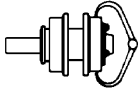

Caliper			Ultrasonic		
Inches	(mm)	% Worn	Inches	(mm)	
8.62	(219.0)	0	1.99	(50.5)	
8.58	(218.0)	5	1.97	(50.0)	
8.54	(217.0)	10	1.95	(49.5)	
8.50	(216.0)	15	1.93	(49.0)	
8.46	(215.0)	20	1.91	(48.5)	
8.42	(214.0)	25	1.89	(48.0)	
8.38	(213.0)	30	1.87	(47.5)	
8.34	(212.0)	35	1.85	(47.0)	
8.30	(211.0)	40	1.83	(46.5)	
8.26	(210.0)	45	1.81	(46.0)	
8.22	(209.0)	50	1.79	(45.5)	
8.18	(208.0)	55	1.77	(45.0)	
8.14	(207.0)	60	1.75	(44.5)	
8.10	(205.5)	65	1.73	(43.9)	
8.06	(204.5)	70	1.71	(43.4)	
8.02	(203.5)	75	1.69	(42.9)	
7.98	(202.5)	79	1.67	(42.4)	
7.94	(201.5)	82	1.65	(41.9)	
7.90	(200.5)	85	1.63	(41.4)	
7.86	(199.5)	88	1.61	(40.9)	
7.82	(198.5)	91	1.59	(40.4)	
7.78	(197.5)	94	1.57	(39.9)	
7.74	(196.5)	97	1.55	(39.4)	
7.70	(195.)	100	1.53	(38.9)	
7.66	(194.5)	103	1.51	(38.4)	
7.62	(193.5)	106	1.49	(37.8)	
7.58	(192.5)	109	1.47	(37.3)	
7.54	(191.5)	112	1.45	(36.8)	
7.50	(190.5)	115	1.43	(36.3)	
7.46	(189.5)	118	1.41	(35.8)	
7.42	(188.5)	121	1.39	(35.3)	

1 Wear Chart: 4781

**Track Rollers (1) (2)**

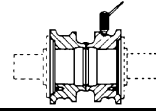
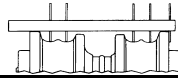
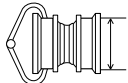

Caliper			Depth Gauge		Ultrasonic	
Inches	(mm)	% Worn	Inches	(mm)	Inches	(mm)
10.63	(270.0)	0	0.86	(22.0)	2.50	(63.5)
10.59	(269.0)	5	0.88	(22.5)	2.48	(63.0)
10.55	(268.0)	10	0.90	(23.0)	2.46	(62.5)
10.51	(267.0)	15	0.92	(23.5)	2.44	(62.0)
10.47	(266.0)	20	0.94	(24.0)	2.42	(61.5)
10.43	(265.0)	25	0.96	(24.5)	2.40	(61.0)
10.39	(264.0)	30	0.98	(25.0)	2.38	(60.5)
10.35	(263.0)	35	1.00	(25.5)	2.36	(59.9)
10.31	(262.0)	40	1.02	(26.0)	2.34	(59.4)
10.27	(261.0)	45	1.04	(26.5)	2.32	(58.9)
10.23	(260.0)	50	1.06	(27.0)	2.30	(58.4)
10.19	(259.0)	55	1.08	(27.5)	2.28	(57.9)
10.15	(258.0)	60	1.10	(28.0)	2.26	(57.4)
10.11	(257.0)	64	1.12	(28.5)	2.24	(56.9)
10.07	(256.0)	67	1.14	(29.0)	2.22	(56.4)
10.03	(255.0)	70	1.16	(29.5)	2.20	(55.9)
9.99	(253.5)	73	1.18	(30.0)	2.18	(55.4)
9.95	(252.5)	76	1.20	(30.5)	2.16	(54.9)
9.91	(251.5)	79	1.22	(31.0)	2.14	(54.4)
9.87	(250.5)	82	1.24	(31.5)	2.12	(53.8)
9.83	(249.5)	85	1.26	(32.0)	2.10	(53.3)
9.79	(248.5)	88	1.28	(32.5)	2.08	(52.8)
9.75	(247.5)	91	1.30	(33.0)	2.06	(52.3)
9.71	(246.5)	94	1.32	(33.5)	2.04	(51.8)
9.67	(245.5)	97	1.34	(34.0)	2.02	(51.3)
9.63	(244.5)	100	1.36	(34.5)	2.00	(50.8)
9.59	(243.5)	103	1.38	(35.0)	1.98	(50.3)
9.55	(242.5)	106	1.40	(35.5)	1.96	(49.8)
9.51	(241.5)	109	1.42	(36.0)	1.94	(49.3)
9.47	(240.5)	112	1.44	(36.5)	1.92	(48.8)
9.43	(239.5)	115	1.46	(37.0)	1.90	(48.3)
9.39	(238.5)	118	1.48	(37.5)	1.88	(47.8)
9.35	(237.5)	121	1.50	(38.0)	1.86	(47.2)

1 Flange diameter is 12.36 in. (314 mm)  
 2 Wear Chart: 5381





## Undercarriage Identification

The easiest way to identify track is to read the part number forged into the link. The following list cross-references link part numbers to the correct wear chart pages.

<b>Model</b>	<b>Pitch</b>	<b>Link Part Number</b>	<b>Wear Chart Pages</b>
943	6.75 in. (171.5 mm)	7T-4173 & 74	From, page 512 – To, page 519
953	6.91 in. (175.5 mm)	7T-4539 & 40	From, page 538 – To, page 547
	7.50 in. (190 mm)	106-1625 & 26 229-6909 & 10 235-2501	From, page 520 – To, page 537
963	8.00 in. (203.2 mm)	7T-4645 & 46 8E-7405 & 06 165-1754 & 55 195-6515 & 16 228-2735 & 36 234-9699	From, page 549 – To, page 568
973	8.50 in. (215.9 mm)	6Y-2593 & 94 7T-4657 & 58 6I-9239 & 40 165-1758 & 59 233-0379 & 80 233-0385 & 86 255-4789 & 90 289-3083 & 84	From, page 570 – To, page 588

# Components

---

## Variables That Affect Wear Life

See the following pages for details on the effects of:

	Page
Controllable Variables	See, page 10
Track Adjustment	See, page 10
Shoe Width	See, page 11
Alignment	See, page 13
Non-Controllable Variables	See, page 17
Soil & Underfoot Conditions	See, page 17
Environmental Variables	See, page 19
Partially Controllable Variables	See, page 22

---

## Components

### Links

See, page 24 through, page 30 for detailed link information.

**Measurement** — Measure track links over the centerline of the pin and bushing bores. See, page 24 for details on measuring links.

**Split Master Links** — Use the assembly procedures on, page 29 for split master links. Refer to, page 505 for bolt torque specifications.

### Pins and Bushings

All hydrostatic loaders use Sealed and Lubricated Track. See, page 31 for details. The following points are specifically for hydrostatic loaders:

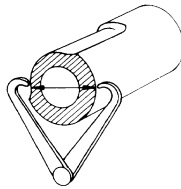

**Measurement** — Use the caliper or the Ultrasonic Wear Indicator to measure all three bushing contact sides: forward, reverse and vertical. Use the most worn position to make projections. It is necessary to measure all three bushing contact sides, because unlike track-type tractors, the vertical dimension is not usually the most worn dimension. In many applications, the reverse drive side wear is the greatest due to reverse operation with a loaded bucket and/or packing.

See details on measurement procedure on, page 31.

The depth gauge should not be used before a bushing turn because it only measures vertical bushing wear. After a bushing turn the depth gauge can be used to approximate wear.

**Dry Joints** — See, page 37 for dry joint inspection procedures and recommended service. If a dry joint is found, measure pitch extension over that one joint. Schedule service if the pitch exceeds these limits:

**Dry Joint Wear Limit**

Model	New Track Pitch	Single Joint Wear Limit
943	6.75 in. (171.5 mm)	7.25 in. (185 mm)
953	6.91 in. (175.5 mm) 7.50 in. (190 mm)	7.50 in. (190 mm) 8.00 in. (203.2 mm)
963	8.00 in. (203.2 mm)	8.67 in. (220 mm)
973	8.50 in. (215.9 mm)	9.12 in. (232 mm)

**Shoes**

See, page 44 through, page 47 for detailed shoe information.

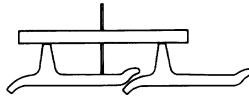

**Measurement** — Use the depth gauge or the Ultrasonic Wear Indicator to measure shoes.

**Shoe & Master Link Bolt Torque Specifications**

Model	Bolt Size	Torque <sup>(1)</sup>	Additional Turn	
			Regular Shoe	Master Link Master Shoe
943	5/8 in.	120 ± 30 ft. lb. 170 ± 40 Nm	1/3 turn	1/2 turn
953				
963	3/4 in.	220 ± 40 ft. lb. 300 ± 50 Nm	1/3 turn	1/2 turn
973				
973	7/8 in.	250 ± 50 ft. lb. 340 ± 70 Nm	1/3 turn	1/2 turn

**SystemOne Shoe and Master Link Track Torque/Turn Specifications\***

Model	Bolt Size	Standard Links Track Shoes		Clamp Master (Open Window)		Clamp Master (Center Strut)	
		Pre Torque	Additional Turn	Pre Torque	Additional Turn	Pre Torque	Additional Turn
953	20 mm	295 ± 18 ft-lb. 400 ± 25 N·m	1/3 turn	221 ± 18 ft-lb. 300 ± 25 N·m	4 x 1/4 turn <sup>(2)</sup>	295 ± 18 ft-lb. 400 ± 25 N·m	1/2 turn
963	22 mm	369 ± 18 ft-lb. 500 ± 25 N·m	1/3 turn	295 ± 18 ft-lb. 400 ± 25 N·m	4 x 1/4 turn <sup>(2)</sup>	369 ± 18 ft-lb. 500 ± 25 N·m	1/2 turn

\* For detailed Installation and Removal of SystemOne Clamp Masters, see Undercarriage Reconditioning Bulletin, REHS2220.

See, page 29 and, page 47 for assembling and torque tightening procedures.

- 1 See, page 29 and, page 47 for assembling and torque tightening procedures.
- 2 Turn each bolt 90 degrees (1/4) at a time for four (4) turns so deflection is uniform. These turns are to be completed in a clockwise pattern.

# Components

---

## Idlers



See, [page 49 through, page 51](#) for detailed idler information.

**Measurement** — Use the depth gauge or the Ultrasonic Wear Indicator to measure idlers.

## Carrier Rollers

See, [page 53](#) for detailed carrier roller information.

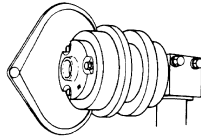

**Measurement** — Use the caliper or the Ultrasonic Wear Indicator to measure carrier rollers.

## Track Rollers

See, [page 56 through, page 59](#) for detailed track roller information. The following points are specifically for hydrostatic loaders.

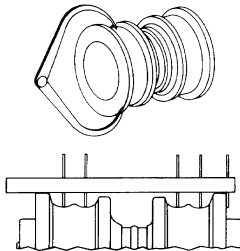

**Measurement** — Track rollers can be measured with either a depth gauge, a caliper or the Ultrasonic Wear Indicator.

For instructions on how to make measurements, [see, page 56](#).

The rear two rollers on machines equipped with sprocket guards can only be measured in the field with the Ultrasonic Wear Indicator. These rollers are critical because they are often the most worn. It is important to measure all rollers whenever the track is removed for service to determine if a swap is needed.

**Roller Swapping** — Higher track speeds, increased debris entry between the sprocket and roller frame and rear mounted engine all contribute to increased rear roller wear on hydrostatic loaders. Machines with unbalanced roller wear may benefit from a roller swap. Use the roller swap guidelines [on, page 59](#) to determine if a swap would be beneficial. Swapping at the bushing turn time may extend roller service life to the link service point reducing downtime and customer cost-per-hour.

**Sprocket and Idler Guards** — Sprocket and idler guards can extend roller life and other components life. See discussion later in this section for details.

## Roller Flange Sequence

From the chart which follows, you will note that the rear roller (the roller nearest the sprocket) is a single flange roller. If a double flange roller were used as the rear roller, interference could occur between the inner flange and the sprocket teeth. Therefore, a double flange roller should NOT usually be placed in the rear position.

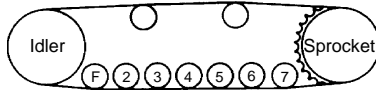

Model	Rollers Per Side	Roller Position						
		F	2	3	4	5	6	7
943	6	S	D	S	S	D	S	
953	6	S	D	S	S	D	S	
963	6	S	D	D	S	D	S	
973	7	S	D	D	S	D	D	S

## Sprockets

See, page 60 through, page 63 for detailed sprocket information. The following points are specifically for hydrostatic loaders:

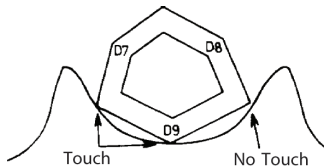

Do not reuse sprocket with turned (or replaced) bushings

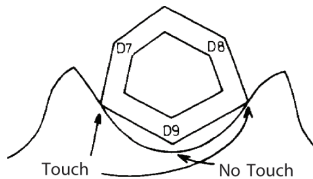

OK to use sprocket with turned (or replaced) bushings

**Measurement** — Use the appropriate sprocket reuse indicator gauge (973 — 5P-8617; 943, 953, 963 — 5P-8616) to determine reusability.

All new and many older hydrostatic loaders are equipped with sprocket guards to reduce the entry of abrasives. Sprockets on these machines cannot be measured in the field. They should be inspected whenever the track is removed for service. Sprocket wear is seldom a critical item. Therefore sprockets can be inspected at service without affecting undercarriage management decisions.

## Components

### Sprocket Bolt Torque Specifications

Model	Bolt Size	Torque	Additional Turn
943	5/8 in.	130 ± 30 ft. lb. 175 ± 40 Nm	+ 1/3 turn
953	M16	130 ± 30 ft. lb. 175 ± 40 Nm	+ 1/3 turn
963	5/8 in.	130 ± 30 ft. lb. 175 ± 40 Nm	+ 1/3 turn
973	3/4 in.	220 ± 40 ft. lb. 300 ± 50 Nm	+ 1/3 turn

Use the torque-tightening method [on, page 63](#).

### Guards

[See, page 64](#) for detailed information on track guiding guards and track roller guards.

**Sprocket Guards** — Sprocket guards shield undercarriage components and reduce the area between the sprocket and roller frame where underfoot material can enter and/or build up. The reduction of material entering the undercarriage system decreases sprocket, bushing, link and track roller wear. Sprocket guards are now standard on new machines and can be retrofitted to earlier hydrostatic loaders. Sprocket guards are most effective in abrasive and high packing conditions.

**Idler Guards** — Idler Guards enclose the open area behind the idler protecting the idler, recoil rod and link assembly from increased wear caused by entrapped underfoot material.

Idler guards are an attachment on new machines and can be retrofitted to earlier hydrostatic loaders. These guards are most effective in demolition debris, rock conditions and sanitary landfill (all with 1 in. to 4 in. size material).

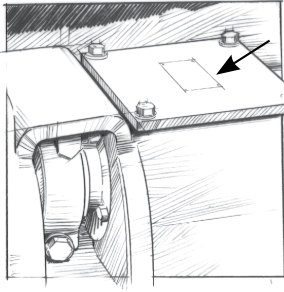

 **WARNING**

**Grease is under high pressure.**

**Grease coming out of the relief valve under pressure can penetrate the body causing injury or death.**

**Do not watch the relief valve to see if grease is escaping. Watch the track or track adjustment cylinder to see if the track is being loosened.**

- 1** Move the machine a distance of two times its length. Bring the machine to a slow stop. Shut off engine.
- 2** Remove the cover for the track adjusting mechanism.

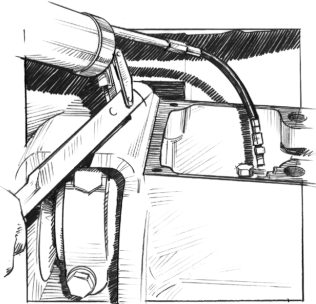

- 3** Add grease with a grease gun to move the idler forward until the track is fully tight.

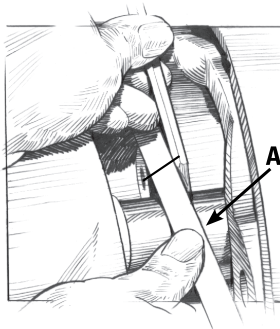

- 4** Use a straight edge against face and make a mark on the rod with a pencil or marking pen even with face.

## Track Adjustment

---

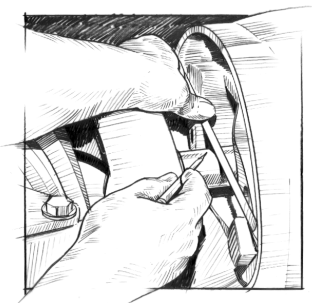

- 5** Mark the rod .4 in. (10 mm) toward the idler from the first mark. Open the relief valve and let the idler move back until the second mark is behind face (A). Close the relief valve. The resulting reference sag should be about 2 in. (50 mm) on these models.

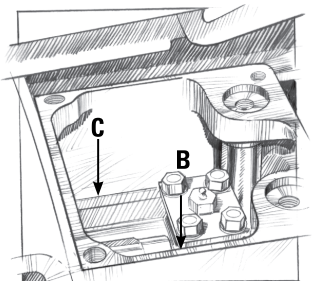

- 6** Use the grease gun and move the idler forward until the second mark is even with face (A).

Note: As track link and rolling components wear approaches service limits, the distance between piston, B (or flange on 963,973) and recoil housing, C, increases. When this exceeds 2 in. or 50 mm (2.36 in. or 60 mm on 963 and 973) consult a Caterpillar Service Manual or call your Caterpillar dealer for idler repositioning procedures.





**943 - 6.75 in. (171.5 mm)**

**Track Links <sup>(1)</sup>  
7T-4173 & 74**

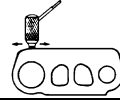
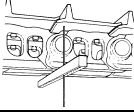

Depth Gauge			Ultrasonic		
Inches	(mm)	% Worn	Inches	(mm)	
3.98	(101.0)	0	1.24	(31.5)	
3.96	(100.5)	6	1.22	(31.0)	
3.94	(100.0)	12	1.20	(30.5)	
3.92	(99.5)	18	1.18	(30.0)	
3.90	(99.0)	24	1.16	(29.5)	
3.88	(98.5)	30	1.14	(29.0)	
3.86	(98.0)	36	1.12	(28.4)	
3.84	(97.5)	42	1.10	(27.9)	
3.82	(97.0)	48	1.08	(27.4)	
3.80	(96.5)	54	1.06	(26.9)	
3.78	(96.0)	60	1.04	(26.4)	
3.76	(95.5)	65	1.02	(25.9)	
3.74	(95.0)	70	1.00	(25.4)	
3.72	(94.5)	75	0.98	(24.9)	
3.70	(94.0)	80	0.96	(24.4)	
3.68	(93.5)	85	0.94	(23.9)	
3.66	(93.0)	90	0.92	(23.4)	
3.64	(92.5)	95	0.90	(22.9)	
3.62	(92.0)	100	0.88	(22.4)	
3.60	(91.5)	105	0.86	(21.8)	
3.58	(91.0)	110	0.84	(21.3)	
3.56	(90.5)	115	0.82	(20.8)	
3.54	(90.0)	120	0.80	(20.3)	

1 Wear Chart: 47

**Bushings <sup>(1)</sup>  
External Wear  
Sealed & Lubricated Track**

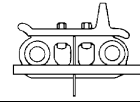
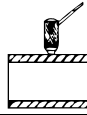
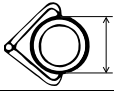

Caliper		Allowable Wear		Ultrasonic		Depth Gauge	
Inches	(mm)	Lesser % Worn	Greater % Worn	Inches	(mm)	Inches	(mm)
2.24	(56.9)	0	0	0.44	(11.2)	2.81	(71.4)
2.22	(56.4)	12	10	0.42	(10.7)	2.79	(70.9)
2.20	(55.9)	24	20	0.40	(10.2)	2.77	(70.4)
2.18	(55.4)	36	30	0.38	(9.7)	2.75	(69.9)
2.16	(54.9)	48	40	0.36	(9.1)	2.73	(69.3)
2.14	(54.4)	60	50	0.34	(8.6)	2.71	(68.8)
2.12	(53.8)	70	60	0.32	(8.1)	2.69	(68.3)
2.10	(53.3)	76	64	0.30	(7.6)	2.67	(67.8)
2.08	(52.8)	82	68	0.28	(7.1)	2.65	(67.3)
2.06	(52.3)	88	72	0.26	(6.6)	2.63	(66.8)
2.04	(51.8)	94	76	0.24	(6.1)	2.61	(66.3)
2.02	(51.3)	100	80	0.22	(5.6)	2.59	(65.8)
2.00	(50.8)	106	84	0.20	(5.1)	2.57	(65.3)
1.98	(50.3)	112	88	0.18	(4.6)	2.55	(64.8)
1.96	(49.8)	118	92	0.16	(4.1)	2.53	(64.3)
1.94	(49.3)	124	96	0.14	(3.6)	2.51	(63.8)
1.92	(48.8)		100	0.12	(3.0)	2.49	(63.2)
1.90	(48.3)		104	0.10	(2.5)	2.47	(62.7)
1.88	(47.8)		108	0.08	(2.0)	2.45	(62.2)
1.86	(47.2)		112	0.06	(1.5)	2.43	(61.7)
1.84	(46.7)		116	0.04	(1.0)	2.41	(61.2)
1.82	(46.2)		120	0.02	(0.5)	2.39	(60.7)

**Note: Do Not Use Depth Gauge Until Bushings Have Been "Turned."**

**943 - 6.75 in. (171.5 mm)**

**Track Shoes <sup>(1)</sup>  
Double Grouser**

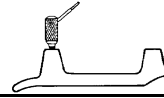
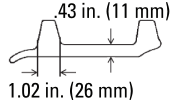
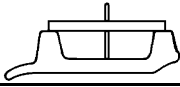

**Depth Gauge**

**Ultrasonic**

Inches	(mm)	% Worn	Inches	(mm)
1.45	(37.0)	0	1.90	(48.3)
1.40	(35.5)	6	1.85	(47.0)
1.35	(34.5)	12	1.80	(45.7)
1.30	(33.0)	18	1.75	(44.5)
1.25	(32.0)	24	1.70	(43.2)
1.20	(30.5)	30	1.65	(41.9)
1.15	(29.0)	35	1.60	(40.6)
1.10	(28.0)	40	1.55	(39.4)
1.05	(26.5)	45	1.50	(38.1)
1.00	(25.5)	50	1.45	(36.8)
0.95	(24.0)	55	1.40	(35.6)
0.90	(23.0)	60	1.35	(34.3)
0.85	(21.5)	65	1.30	(33.0)
0.80	(20.5)	70	1.25	(31.8)
0.75	(19.0)	75	1.20	(30.5)
0.70	(18.0)	80	1.15	(29.2)
0.65	(16.5)	85	1.10	(27.9)
0.60	(15.0)	90	1.05	(26.7)
0.55	(14.0)	95	1.00	(25.4)
0.50	(12.5)	100	0.95	(24.1)
0.45	(11.5)	105	0.90	(22.9)
0.40	(10.0)	110	0.85	(21.6)
0.35	(9.0)	115	0.80	(20.3)
0.30	(7.5)	120	0.75	(19.1)

**Track Shoes <sup>(1)</sup>  
Triple Grouser**

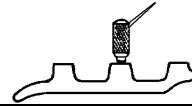
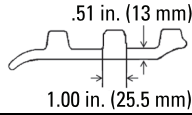
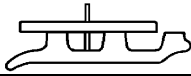

**Depth Gauge**

**Ultrasonic**

Inches	(mm)	% Worn	Inches	(mm)
0.95	(24.0)	0	1.50	(38.1)
0.90	(23.0)	8	1.45	(36.8)
0.85	(21.5)	16	1.40	(35.6)
0.80	(20.5)	23	1.35	(34.3)
0.75	(19.0)	30	1.30	(33.0)
0.70	(18.0)	37	1.25	(31.8)
0.65	(16.5)	44	1.20	(30.5)
0.60	(15.0)	51	1.15	(29.2)
0.55	(14.0)	58	1.10	(27.9)
0.50	(12.5)	65	1.05	(26.7)
0.45	(11.5)	72	1.00	(25.4)
0.40	(10.0)	79	0.95	(24.1)
0.35	(9.0)	86	0.90	(22.9)
0.30	(7.5)	93	0.85	(21.6)
0.25	(6.5)	100	0.80	(20.3)
0.20	(5.0)	107	0.75	(19.1)
0.15	(4.0)	114	0.70	(17.8)
0.10	(2.5)	121	0.65	(16.5)

# 943 - 6.75 in. (171.5 mm)

## Idlers <sup>(1)</sup> <sup>(2)</sup> <sup>(3)</sup>

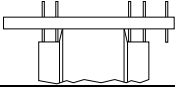

Depth Gauge		
Inches	(mm)	% Worn
0.66	(17.0)	0
0.68	(17.5)	8
0.70	(18.0)	16
0.72	(18.5)	24
0.74	(19.0)	32
0.76	(19.5)	40
0.78	(20.0)	48
0.80	(20.5)	56
0.82	(21.0)	64
0.84	(21.5)	72
0.86	(22.0)	76
0.88	(22.5)	79
0.90	(23.0)	82
0.92	(23.5)	85
0.94	(24.0)	88
0.96	(24.5)	91
0.98	(25.0)	94
1.00	(25.5)	97
1.02	(26.0)	100
1.04	(26.5)	103
1.06	(27.0)	106
1.08	(27.5)	109
1.10	(28.0)	112
1.12	(28.5)	115
1.14	(29.0)	118
1.16	(29.5)	121

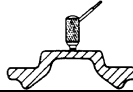

Ultrasonic		Center Flange Wear	
Inches	(mm)	Inches	(mm)
0.36	(9.1)	0.00	(0.0)
0.34	(8.6)	0.02	(0.5)
0.32	(8.1)	0.04	(1.0)
0.30	(7.6)	0.06	(1.5)
0.28	(7.1)	0.08	(2.0)
0.26	(6.6)	0.10	(2.5)
0.24	(6.1)	0.12	(3.0)
0.22	(5.6)	0.14	(3.5)
0.20	(5.1)	0.16	(4.0)
0.18	(4.6)	0.18	(4.5)
0.16	(4.1)	0.20	(5.0)
0.14	(3.6)	0.22	(5.5)
0.12	(3.0)	0.24	(6.0)
0.10	(2.5)	0.26	(6.5)
0.08	(2.0)	0.28	(7.0)
0.06	(1.5)	0.30	(7.5)
0.04	(1.0)	0.32	(8.0)
0.02	(0.5)	0.34	(8.5)

### NOTE

Ultrasonic measurement is to determine flange wear only.

- 1 Flange width is 2.70 in. (68.5 mm)
- 2 New tread diameter is 23.15 in. (588 mm)
- 3 Wear Chart: 4343

Carrier Rollers <sup>(1)</sup>

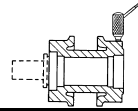
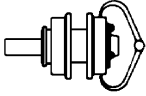

Caliper			Ultrasonic	
Inches	(mm)	% Worn	Inches	(mm)
6.26	(159.0)	0	1.63	(41.4)
6.20	(157.5)	7	1.60	(40.6)
6.14	(156.0)	14	1.57	(39.9)
6.08	(154.5)	21	1.54	(39.1)
6.02	(153.0)	28	1.51	(38.4)
5.96	(151.5)	35	1.48	(37.6)
5.90	(150.0)	42	1.45	(36.8)
5.84	(148.5)	49	1.42	(36.1)
5.78	(147.0)	56	1.39	(35.3)
5.72	(145.5)	63	1.36	(34.5)
5.66	(144.0)	70	1.33	(33.8)
5.60	(142.0)	77	1.30	(33.0)
5.54	(140.5)	84	1.27	(32.3)
5.48	(139.0)	88	1.24	(31.5)
5.42	(137.5)	92	1.21	(30.7)
5.36	(136.0)	96	1.18	(30.0)
5.30	(134.5)	100	1.15	(29.2)
5.24	(133.0)	104	1.12	(28.4)
5.18	(131.5)	108	1.09	(27.7)
5.12	(130.0)	112	1.06	(26.9)
5.06	(128.5)	116	1.03	(26.2)
5.00	(127.0)	120	1.00	(25.4)

# 943 - 6.75 in. (171.5 mm)

## Track Rollers <sup>(1) (2)</sup> Rollers with End Collars

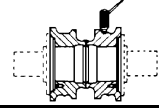
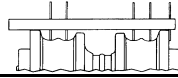
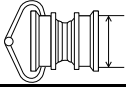

Caliper		% Worn	Depth Gauge		Ultrasonic	
Inches	(mm)		Inches	(mm)	Inches	(mm)
6.89	(175.0)	0	0.47	(12.0)	1.44	(36.6)
6.85	(174.0)	4	0.49	(12.5)	1.42	(36.1)
6.81	(173.0)	8	0.51	(13.0)	1.40	(35.6)
6.77	(172.0)	12	0.53	(13.5)	1.38	(35.1)
6.73	(171.0)	16	0.55	(14.0)	1.36	(34.5)
6.69	(170.0)	20	0.57	(14.5)	1.34	(34.0)
6.65	(169.0)	24	0.59	(15.0)	1.32	(33.5)
6.61	(168.0)	28	0.61	(15.5)	1.30	(33.0)
6.57	(167.0)	32	0.63	(16.0)	1.28	(32.5)
6.53	(166.0)	36	0.65	(16.5)	1.26	(32.0)
6.49	(165.0)	40	0.67	(17.0)	1.24	(31.5)
6.45	(164.0)	43	0.69	(17.5)	1.22	(31.0)
6.41	(163.0)	46	0.71	(18.0)	1.20	(30.5)
6.37	(162.0)	49	0.73	(18.5)	1.18	(30.0)
6.33	(161.0)	52	0.75	(19.0)	1.16	(29.5)
6.29	(160.0)	55	0.77	(19.5)	1.14	(29.0)
6.25	(159.0)	58	0.79	(20.0)	1.12	(28.4)
6.21	(157.5)	61	0.81	(20.5)	1.10	(27.9)
6.17	(156.5)	64	0.83	(21.0)	1.08	(27.4)
6.13	(155.5)	67	0.85	(21.5)	1.06	(26.9)
6.09	(154.5)	70	0.87	(22.0)	1.04	(26.4)
6.05	(153.5)	73	0.89	(22.5)	1.02	(25.9)
6.01	(152.5)	76	0.91	(23.0)	1.00	(25.4)
5.97	(151.5)	79	0.93	(23.5)	0.98	(24.9)
5.93	(150.5)	82	0.95	(24.0)	0.96	(24.4)
5.89	(149.5)	85	0.97	(24.5)	0.94	(23.9)
5.85	(148.5)	88	0.99	(25.0)	0.92	(23.4)
5.81	(147.5)	91	1.01	(25.5)	0.90	(22.9)
5.77	(146.5)	94	1.03	(26.0)	0.88	(22.4)
5.73	(145.5)	97	1.05	(26.5)	0.86	(21.8)
5.69	(144.5)	100	1.07	(27.0)	0.84	(21.3)
5.65	(143.5)	103	1.09	(27.5)	0.82	(20.8)
5.61	(142.5)	106	1.11	(28.0)	0.80	(20.3)
5.57	(141.5)	109	1.13	(28.5)	0.78	(19.8)
5.53	(140.5)	112	1.15	(29.0)	0.76	(19.3)
5.49	(139.5)	115	1.17	(29.5)	0.74	(18.8)
5.45	(138.5)	118	1.19	(30.0)	0.72	(18.3)
5.41	(137.5)	121	1.21	(30.5)	0.70	(17.8)

1 Flange diameter is 7.83 in. (199 mm)

2 Wear Chart: 5251



**Track Rollers <sup>(1) (2)</sup>  
Rollers with Retainers**

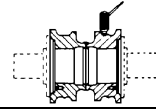
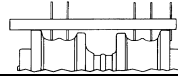

Caliper			Depth Gauge		Ultrasonic	
Inches	(mm)	% Worn	Inches	(mm)	Inches	(mm)
6.89	(175.0)	0	0.47	(12.0)	1.55	(39.4)
6.85	(174.0)	4	0.49	(12.5)	1.53	(38.9)
6.81	(173.0)	8	0.51	(13.0)	1.51	(38.4)
6.77	(172.0)	12	0.53	(13.5)	1.49	(37.8)
6.73	(171.0)	16	0.55	(14.0)	1.47	(37.3)
6.69	(170.0)	20	0.57	(14.5)	1.45	(36.8)
6.65	(169.0)	24	0.59	(15.0)	1.43	(36.3)
6.61	(168.0)	28	0.61	(15.5)	1.41	(35.8)
6.57	(167.0)	32	0.63	(16.0)	1.39	(35.3)
6.53	(166.0)	36	0.65	(16.5)	1.37	(34.8)
6.49	(165.0)	40	0.67	(17.0)	1.35	(34.3)
6.45	(164.0)	43	0.69	(17.5)	1.33	(33.8)
6.41	(163.0)	46	0.71	(18.0)	1.31	(33.3)
6.37	(162.0)	49	0.73	(18.5)	1.29	(32.8)
6.33	(161.0)	52	0.75	(19.0)	1.27	(32.3)
6.29	(160.0)	55	0.77	(19.5)	1.25	(31.8)
6.25	(159.0)	58	0.79	(20.0)	1.23	(31.2)
6.21	(157.5)	61	0.81	(20.5)	1.21	(30.7)
6.17	(156.5)	64	0.83	(21.0)	1.19	(30.2)
6.13	(155.5)	67	0.85	(21.5)	1.17	(29.7)
6.09	(154.5)	70	0.87	(22.0)	1.15	(29.2)
6.05	(153.5)	73	0.89	(22.5)	1.13	(28.7)
6.01	(152.5)	76	0.91	(23.0)	1.11	(28.2)
5.97	(151.5)	79	0.93	(23.5)	1.09	(27.7)
5.93	(150.5)	82	0.95	(24.0)	1.07	(27.2)
5.89	(149.5)	85	0.97	(24.5)	1.05	(26.7)
5.85	(148.5)	88	0.99	(25.0)	1.03	(26.2)
5.81	(147.5)	91	1.01	(25.5)	1.01	(25.7)
5.77	(146.5)	94	1.03	(26.0)	0.99	(25.1)
5.73	(145.5)	97	1.05	(26.5)	0.97	(24.6)
5.69	(144.5)	100	1.07	(27.0)	0.95	(24.1)
5.65	(143.5)	103	1.09	(27.5)	0.93	(23.6)
5.61	(142.5)	106	1.11	(28.0)	0.91	(23.1)
5.57	(141.5)	109	1.13	(28.5)	0.89	(22.6)
5.53	(140.5)	112	1.15	(29.0)	0.87	(22.1)
5.49	(139.5)	115	1.17	(29.5)	0.85	(21.6)
5.45	(138.5)	118	1.19	(30.0)	0.83	(21.1)
5.41	(137.5)	121	1.21	(30.5)	0.81	(20.6)

1 Flange diameter is 7.80 in. (198 mm)  
 2 Wear Chart: 5247

**953 - 7.50 in. (190 mm)**

**Track Links <sup>(1)</sup>  
SystemOne Track  
235-2501**

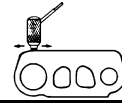
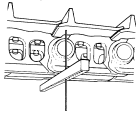

Depth Gauge			Ultrasonic	
Inches	(mm)	% Worn	Inches	(mm)
4.78	(121.5)	0	1.45	(36.8)
4.76	(121.0)	5	1.43	(36.3)
4.74	(120.5)	10	1.41	(35.8)
4.72	(120.0)	15	1.39	(35.3)
4.70	(119.5)	20	1.37	(34.8)
4.68	(119.0)	25	1.35	(34.3)
4.66	(118.5)	30	1.33	(33.8)
4.64	(118.0)	35	1.31	(33.3)
4.62	(117.5)	40	1.29	(32.8)
4.60	(117.0)	45	1.27	(32.3)
4.58	(116.5)	50	1.25	(31.8)
4.56	(116.0)	55	1.23	(31.2)
4.54	(115.5)	60	1.21	(30.7)
4.52	(115.0)	65	1.19	(30.2)
4.50	(114.5)	70	1.17	(29.7)
4.48	(114.0)	75	1.15	(29.2)
4.46	(113.5)	80	1.13	(28.7)
4.44	(113.0)	84	1.11	(28.2)
4.42	(112.5)	88	1.09	(27.7)
4.40	(112.0)	92	1.07	(27.2)
4.38	(111.5)	96	1.05	(26.7)
4.36	(110.5)	100	1.03	(26.2)
4.34	(110.0)	104	1.01	(25.7)
4.32	(109.5)	108	0.99	(25.1)
4.30	(109.0)	112	0.97	(24.6)
4.28	(108.5)	116	0.95	(24.1)
4.26	(108.0)	120	0.93	(23.6)

**Track Links <sup>(1)</sup>  
Heavy Duty Track  
Rotating Bushing Track  
106-1625 & 26**

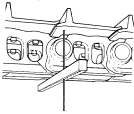

Depth Gauge			Ultrasonic	
Inches	(mm)	% Worn	Inches	(mm)
4.68	(119.0)	0	1.53	(38.9)
4.66	(118.5)	5	1.51	(38.4)
4.64	(118.0)	10	1.49	(37.8)
4.62	(117.5)	15	1.47	(37.3)
4.60	(117.0)	20	1.45	(36.8)
4.58	(116.5)	25	1.43	(36.3)
4.56	(116.0)	30	1.41	(35.8)
4.54	(115.5)	35	1.39	(35.3)
4.52	(115.0)	40	1.37	(34.8)
4.50	(114.5)	45	1.35	(34.3)
4.48	(114.0)	50	1.33	(33.8)
4.46	(113.5)	55	1.31	(33.3)
4.44	(113.0)	60	1.29	(32.8)
4.42	(112.5)	65	1.27	(32.3)
4.40	(112.0)	70	1.25	(31.8)
4.38	(111.5)	75	1.23	(31.2)
4.36	(110.5)	80	1.21	(30.7)
4.34	(110.0)	84	1.19	(30.2)
4.32	(109.5)	88	1.17	(29.7)
4.30	(109.0)	92	1.15	(29.2)
4.28	(108.5)	96	1.13	(28.7)
4.26	(108.0)	100	1.11	(28.2)
4.24	(107.5)	104	1.09	(27.7)
4.22	(107.0)	108	1.07	(27.2)
4.20	(106.5)	112	1.05	(26.7)
4.18	(106.0)	116	1.03	(26.2)
4.16	(105.5)	120	1.01	(25.7)

**953 - 7.50 in. (190 mm)**

**Track Links <sup>(1)</sup>  
Enhanced SALT Track  
229-6909 & 10**

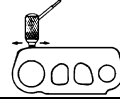
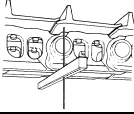

Depth Gauge			Ultrasonic	
Inches	(mm)	% Worn	Inches	(mm)
4.48	(114.0)	0	1.43	(36.3)
4.46	(113.5)	5	1.41	(35.8)
4.44	(113.0)	10	1.39	(35.3)
4.42	(112.5)	15	1.37	(34.8)
4.40	(112.0)	20	1.35	(34.3)
4.38	(111.5)	25	1.33	(33.8)
4.36	(110.5)	30	1.31	(33.3)
4.34	(110.0)	35	1.29	(32.8)
4.32	(109.5)	40	1.27	(32.3)
4.30	(109.0)	45	1.25	(31.8)
4.28	(108.5)	50	1.23	(31.2)
4.26	(108.0)	55	1.21	(30.7)
4.24	(107.5)	60	1.19	(30.2)
4.22	(107.0)	65	1.17	(29.7)
4.20	(106.5)	70	1.15	(29.2)
4.18	(106.0)	75	1.13	(28.7)
4.16	(105.5)	80	1.11	(28.2)
4.14	(105.0)	84	1.09	(27.7)
4.12	(104.5)	88	1.07	(27.2)
4.10	(104.0)	92	1.05	(26.7)
4.08	(103.5)	96	1.03	(26.2)
4.06	(103.0)	100	1.01	(25.7)
4.04	(102.5)	104	0.99	(25.1)
4.02	(102.0)	108	0.97	(24.6)
4.00	(101.5)	112	0.95	(24.1)
3.98	(101.0)	116	0.93	(23.6)
3.96	(100.5)	120	0.91	(23.1)

**Bushings <sup>(1)</sup>**  
**External Wear**  
**SystemOne Track**

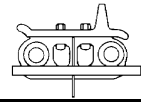
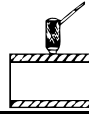
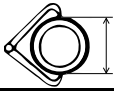

Caliper			Ultrasonic		Depth Gauge	
Inches	(mm)	% Worn	Inches	(mm)	Inches	(mm)
2.56	(65.0)	0	0.48	(12.2)	3.28	(83.3)
2.54	(64.5)	6	0.47	(11.9)	3.27	(83.1)
2.52	(64.0)	12	0.46	(11.7)	3.26	(82.8)
2.50	(63.5)	18	0.45	(11.4)	3.25	(82.6)
2.48	(63.0)	24	0.44	(11.2)	3.24	(82.3)
2.46	(62.5)	30	0.43	(10.9)	3.23	(82.0)
2.44	(62.0)	36	0.42	(10.7)	3.22	(81.8)
2.42	(61.5)	42	0.41	(10.4)	3.21	(81.5)
2.40	(61.0)	46	0.40	(10.2)	3.20	(81.3)
2.38	(60.5)	49	0.39	(9.9)	3.19	(81.0)
2.36	(59.9)	52	0.38	(9.7)	3.18	(80.8)
2.34	(59.4)	55	0.37	(9.4)	3.17	(80.5)
2.32	(58.9)	58	0.36	(9.1)	3.16	(80.3)
2.30	(58.4)	61	0.35	(8.9)	3.15	(80.0)
2.28	(57.9)	64	0.34	(8.6)	3.14	(79.8)
2.26	(57.4)	67	0.33	(8.4)	3.13	(79.5)
2.24	(56.9)	70	0.32	(8.1)	3.12	(79.2)
2.22	(56.4)	73	0.31	(7.9)	3.11	(79.0)
2.20	(55.9)	76	0.30	(7.6)	3.10	(78.7)
2.18	(55.4)	79	0.29	(7.4)	3.09	(78.5)
2.16	(54.9)	82	0.28	(7.1)	3.08	(78.2)
2.14	(54.4)	85	0.27	(6.9)	3.07	(78.0)
2.12	(53.8)	88	0.26	(6.6)	3.06	(77.7)
2.10	(53.3)	91	0.25	(6.3)	3.05	(77.5)
2.08	(52.8)	94	0.24	(6.1)	3.04	(77.2)
2.06	(52.3)	97	0.23	(5.8)	3.03	(77.0)
2.04	(51.8)	100	0.22	(5.6)	3.02	(76.7)
2.02	(51.3)	103	0.21	(5.3)	3.01	(76.5)
2.00	(50.8)	106	0.20	(5.1)	3.00	(76.2)
1.98	(50.3)	109	0.19	(4.8)	2.99	(75.9)
1.96	(49.8)	112	0.18	(4.6)	2.98	(75.7)
1.94	(49.3)	115	0.17	(4.3)	2.97	(75.4)
1.92	(48.8)	118	0.16	(4.1)	2.96	(75.2)
1.90	(48.3)	121	0.15	(3.8)	2.95	(74.9)

**953 - 7.50 in. (190 mm)**

**Bushings <sup>(1)</sup>  
External Wear  
Heavy Duty Track**

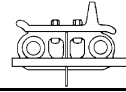
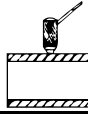
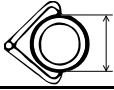

Caliper		Allowable Wear		Ultrasonic		Depth Gauge	
		Lesser	Greater				
Inches	(mm)	% Worn	% Worn	Inches	(mm)	Inches	(mm)
2.56	(65.0)	0	0	0.51	(13.0)	3.19	(81.0)
2.54	(64.5)	10	8	0.49	(12.4)	3.17	(80.5)
2.52	(64.0)	20	16	0.47	(11.9)	3.15	(80.0)
2.50	(63.5)	30	24	0.45	(11.4)	3.13	(79.5)
2.48	(63.0)	40	32	0.43	(10.9)	3.11	(79.0)
2.46	(62.5)	50	40	0.41	(10.4)	3.09	(78.5)
2.44	(62.0)	60	48	0.39	(9.9)	3.07	(78.0)
2.42	(61.5)	70	52	0.37	(9.4)	3.05	(77.5)
2.40	(61.0)	76	56	0.35	(8.9)	3.03	(77.0)
2.38	(60.5)	80	60	0.33	(8.4)	3.01	(76.5)
2.36	(59.9)	84	64	0.31	(7.9)	2.99	(75.9)
2.34	(59.4)	88	68	0.29	(7.4)	2.97	(75.4)
2.32	(58.9)	92	72	0.27	(6.9)	2.95	(74.9)
2.30	(58.4)	96	76	0.25	(6.3)	2.93	(74.4)
2.28	(57.9)	100	80	0.23	(5.8)	2.91	(73.9)
2.26	(57.4)	104	84	0.21	(5.3)	2.89	(73.4)
2.24	(56.9)	108	88	0.19	(4.8)	2.87	(72.9)
2.22	(56.4)	112	92	0.17	(4.3)	2.85	(72.4)
2.20	(55.9)	116	96	0.15	(3.8)	2.83	(71.9)
2.18	(55.4)	120	100	0.13	(3.3)	2.81	(71.4)
2.16	(54.9)		104	0.11	(2.8)	2.79	(70.9)
2.14	(54.4)		108	0.09	(2.3)	2.77	(70.4)
2.12	(53.8)		112	0.07	(1.8)	2.75	(69.9)
2.10	(53.3)		116	0.05	(1.3)	2.73	(69.3)
2.08	(52.8)		120	0.03	(0.8)	2.71	(68.8)

1 Wear Chart: 682

**Bushings <sup>(1)</sup>  
External Wear  
Rotating Bushing Track**

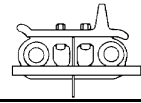
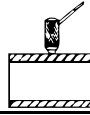
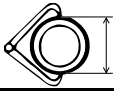

Caliper			Ultrasonic		Depth Gauge	
Inches	(mm)	% Worn	Inches	(mm)	Inches	(mm)
2.56	(65.0)	0	0.52	(13.2)	3.19	(81.0)
2.52	(64.0)	8	0.50	(12.7)	3.17	(80.5)
2.48	(63.0)	16	0.48	(12.2)	3.15	(80.0)
2.44	(62.0)	24	0.46	(11.7)	3.13	(79.5)
2.40	(61.0)	32	0.44	(11.2)	3.11	(79.0)
2.36	(59.9)	40	0.42	(10.7)	3.09	(78.5)
2.32	(58.9)	44	0.40	(10.2)	3.07	(78.0)
2.28	(57.9)	48	0.38	(9.7)	3.05	(77.5)
2.24	(56.9)	52	0.36	(9.1)	3.03	(77.0)
2.20	(55.9)	56	0.34	(8.6)	3.01	(76.5)
2.16	(54.9)	60	0.32	(8.1)	2.99	(75.9)
2.12	(53.8)	64	0.30	(7.6)	2.97	(75.4)
2.08	(52.8)	68	0.28	(7.1)	2.95	(74.9)
2.04	(51.8)	72	0.26	(6.6)	2.93	(74.4)
2.00	(50.8)	76	0.24	(6.1)	2.91	(73.9)
1.96	(49.8)	80	0.22	(5.6)	2.89	(73.4)
1.92	(48.8)	84	0.20	(5.1)	2.87	(72.9)
1.88	(47.8)	88	0.18	(4.6)	2.85	(72.4)
1.84	(46.7)	92	0.16	(4.1)	2.83	(71.9)
1.80	(45.7)	96	0.14	(3.6)	2.81	(71.4)
1.76	(44.7)	100	0.12	(3.0)	2.79	(70.9)
1.72	(43.7)	104	0.10	(2.5)	2.77	(70.4)
1.68	(42.7)	108	0.08	(2.0)	2.75	(69.9)
1.64	(41.7)	112	0.06	(1.5)	2.73	(69.3)
1.60	(40.6)	116	0.04	(1.0)	2.71	(68.8)
1.56	(39.6)	120	0.02	(0.5)	2.69	(68.3)

**953 - 7.50 in. (190 mm)**

**Bushings <sup>(1)</sup>  
External Wear  
Sealed & Lubricated Track  
Enhanced SALT Track**

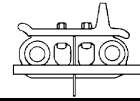
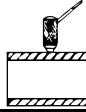

Caliper		Allowable Wear		Ultrasonic		Depth Gauge	
		Lesser % Worn	Greater % Worn	Inches	(mm)	Inches	(mm)
Inches	(mm)						
2.53	(64.3)	0	0	0.52	(13.2)	3.11	(79.0)
2.51	(63.8)	10	8	0.50	(12.7)	3.09	(78.5)
2.49	(63.2)	20	16	0.48	(12.2)	3.07	(78.0)
2.47	(62.7)	30	24	0.46	(11.7)	3.05	(77.5)
2.45	(62.2)	40	32	0.44	(11.2)	3.03	(77.0)
2.43	(61.7)	50	40	0.42	(10.7)	3.01	(76.5)
2.41	(61.2)	60	44	0.40	(10.2)	2.99	(75.9)
2.39	(60.7)	68	48	0.38	(9.7)	2.97	(75.4)
2.37	(60.2)	72	52	0.36	(9.1)	2.95	(74.9)
2.35	(59.7)	76	56	0.34	(8.6)	2.93	(74.4)
2.33	(59.2)	80	60	0.32	(8.1)	2.91	(73.9)
2.31	(58.7)	84	64	0.30	(7.6)	2.89	(73.4)
2.29	(58.2)	88	68	0.28	(7.1)	2.87	(72.9)
2.27	(57.7)	92	72	0.26	(6.6)	2.85	(72.4)
2.25	(57.2)	96	76	0.24	(6.1)	2.83	(71.9)
2.23	(56.6)	100	80	0.22	(5.6)	2.81	(71.4)
2.21	(56.1)	104	84	0.20	(5.1)	2.79	(70.9)
2.19	(55.6)	108	88	0.18	(4.6)	2.77	(70.4)
2.17	(55.1)	112	92	0.16	(4.1)	2.75	(69.9)
2.15	(54.6)	116	96	0.14	(3.6)	2.73	(69.3)
2.13	(54.1)	120	100	0.12	(3.0)	2.71	(68.8)
2.11	(53.6)		104	0.10	(2.5)	2.69	(68.3)
2.09	(53.1)		108	0.08	(2.0)	2.67	(67.8)
2.07	(52.6)		112	0.06	(1.5)	2.65	(67.3)
2.05	(52.1)		116	0.04	(1.0)	2.63	(66.8)
2.03	(51.6)		120	0.02	(0.5)	2.61	(66.3)

**Note: Do Not Use Depth Gauge Until Bushings Have Been "Turned."**



**Track Shoes <sup>(1)</sup>  
Extreme Service**

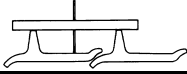

**Depth Gauge**

**Ultrasonic**

Inches	(mm)	% Worn	Inches	(mm)
2.55	(65.0)	0	3.15	(80.0)
2.45	(62.0)	6	3.05	(77.5)
2.35	(59.5)	12	2.95	(74.9)
2.25	(57.0)	18	2.85	(72.4)
2.15	(54.5)	24	2.75	(69.9)
2.05	(52.0)	30	2.65	(67.3)
1.95	(49.5)	36	2.55	(64.8)
1.85	(47.0)	42	2.45	(62.2)
1.75	(44.5)	48	2.35	(59.7)
1.65	(42.0)	54	2.25	(57.2)
1.55	(39.5)	60	2.15	(54.6)
1.45	(37.0)	66	2.05	(52.1)
1.35	(34.5)	72	1.95	(49.5)
1.25	(32.0)	78	1.85	(47.0)
1.15	(29.0)	84	1.75	(44.5)
1.05	(26.5)	90	1.65	(41.9)
0.95	(24.0)	95	1.55	(39.4)
0.85	(21.5)	100	1.45	(36.8)
0.75	(19.0)	105	1.35	(34.3)
0.65	(16.5)	110	1.25	(31.8)
0.55	(14.0)	115	1.15	(29.2)
0.45	(11.5)	120	1.05	(26.7)

**953 - 7.50 in. (190 mm)**

**Track Shoes <sup>(1)</sup>  
Moderate Service**

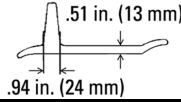
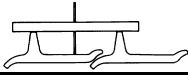

Depth Gauge			Ultrasonic	
Inches	(mm)	% Worn	Inches	(mm)
2.25	(57.0)	0	2.75	(69.9)
2.20	(56.0)	4	2.70	(68.6)
2.15	(54.5)	8	2.65	(67.3)
2.10	(53.5)	12	2.60	(66.0)
2.05	(52.0)	16	2.55	(64.8)
2.00	(51.0)	20	2.50	(63.5)
1.95	(49.5)	24	2.45	(62.2)
1.90	(48.5)	28	2.40	(61.0)
1.85	(47.0)	32	2.35	(59.7)
1.80	(45.5)	36	2.30	(58.4)
1.75	(44.5)	40	2.25	(57.2)
1.70	(43.0)	44	2.20	(55.9)
1.65	(42.0)	48	2.15	(54.6)
1.60	(40.5)	52	2.10	(53.3)
1.55	(39.5)	56	2.05	(52.1)
1.50	(38.0)	60	2.00	(50.8)
1.45	(37.0)	64	1.95	(49.5)
1.40	(35.5)	67	1.90	(48.3)
1.35	(34.5)	70	1.85	(47.0)
1.30	(33.0)	73	1.80	(45.7)
1.25	(32.0)	76	1.75	(44.5)
1.20	(30.5)	79	1.70	(43.2)
1.15	(29.0)	82	1.65	(41.9)
1.10	(28.0)	85	1.60	(40.6)
1.05	(26.5)	88	1.55	(39.4)
1.00	(25.5)	91	1.50	(38.1)
0.95	(24.0)	94	1.45	(36.8)
0.90	(23.0)	97	1.40	(35.6)
0.85	(21.5)	100	1.35	(34.3)
0.80	(20.5)	103	1.30	(33.0)
0.75	(19.0)	106	1.25	(31.8)
0.70	(18.0)	109	1.20	(30.5)
0.65	(16.5)	112	1.15	(29.2)
0.60	(15.0)	115	1.10	(27.9)
0.55	(14.0)	118	1.05	(26.7)
0.50	(12.5)	121	1.00	(25.4)

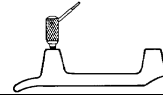
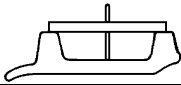
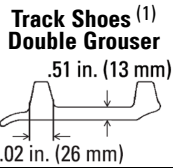

**Depth Gauge**

**Ultrasonic**

<b>Inches</b>	<b>(mm)</b>	<b>% Worn</b>	<b>Inches</b>	<b>(mm)</b>
1.40	(35.5)	0	1.89	(48.0)
1.35	(34.5)	6	1.84	(46.7)
1.30	(33.0)	12	1.79	(45.5)
1.25	(32.0)	18	1.74	(44.2)
1.20	(30.5)	24	1.69	(42.9)
1.15	(29.0)	30	1.64	(41.7)
1.10	(28.0)	36	1.59	(40.4)
1.05	(26.5)	42	1.54	(39.1)
1.00	(25.5)	48	1.49	(37.8)
0.95	(24.0)	54	1.44	(36.6)
0.90	(23.0)	60	1.39	(35.3)
0.85	(21.5)	65	1.34	(34.0)
0.80	(20.5)	70	1.29	(32.8)
0.75	(19.0)	75	1.24	(31.5)
0.70	(18.0)	80	1.19	(30.2)
0.65	(16.5)	85	1.14	(29.0)
0.60	(15.0)	90	1.09	(27.7)
0.55	(14.0)	95	1.04	(26.4)
0.50	(12.5)	100	0.99	(25.1)
0.45	(11.5)	105	0.94	(23.9)
0.40	(10.0)	110	0.89	(22.6)
0.35	(9.0)	115	0.84	(21.3)
0.30	(7.5)	120	0.79	(20.1)

**Idlers <sup>(1)</sup> <sup>(2)</sup> <sup>(3)</sup>**  
**Center Tread Idler**

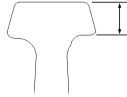

Ultrasonic, Depth Gauge or Caliper		
Inches	(mm)	% Worn
1.10	(28.0)	0
1.08	(27.5)	4
1.06	(27.0)	8
1.04	(26.5)	12
1.02	(26.0)	16
1.00	(25.5)	20
0.98	(25.0)	24
0.96	(24.5)	28
0.94	(24.0)	32
0.92	(23.5)	36
0.90	(23.0)	40
0.88	(22.5)	44
0.86	(22.0)	48
0.84	(21.5)	52
0.82	(21.0)	55
0.80	(20.5)	58
0.78	(20.0)	61
0.76	(19.5)	64
0.74	(19.0)	67
0.72	(18.5)	70
0.70	(18.0)	73
0.68	(17.5)	76
0.66	(17.0)	79
0.64	(16.5)	82
0.62	(15.5)	85
0.60	(15.0)	88
0.58	(14.5)	91
0.56	(14.0)	94
0.54	(13.5)	97
0.52	(13.0)	100
0.50	(12.5)	103
0.48	(12.0)	106
0.46	(11.5)	109
0.44	(11.0)	112
0.42	(10.5)	115
0.40	(10.0)	118
0.38	(9.5)	121

- 1 New Tread diameter is 24.45 in. (621 mm) or 27.52 in. (699 mm)
- 2 For measuring instructions, reference General Information topic *Idler Wear – Center Tread Idlers* on, page 51.
- 3 Wear Chart: 4080

Idlers <sup>(1)</sup> <sup>(2)</sup> <sup>(3)</sup>  
Conventional

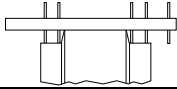

Depth Gauge		
Inches	(mm)	% Worn
0.74	(19.0)	0
0.76	(19.5)	7
0.78	(20.0)	14
0.80	(20.5)	21
0.82	(21.0)	28
0.84	(21.5)	35
0.86	(22.0)	42
0.88	(22.5)	49
0.90	(23.0)	56
0.92	(23.5)	63
0.94	(24.0)	67
0.96	(24.5)	70
0.98	(25.0)	73
1.00	(25.5)	76
1.02	(26.0)	79
1.04	(26.5)	82
1.06	(27.0)	85
1.08	(27.5)	88
1.10	(28.0)	91
1.12	(28.5)	94
1.14	(29.0)	97
1.16	(29.5)	100
1.18	(30.0)	103
1.20	(30.5)	106
1.22	(31.0)	109
1.24	(31.5)	112
1.26	(32.0)	115
1.28	(32.5)	118
1.30	(33.0)	121

Ultrasonic		Center Flange Wear	
Inches	(mm)	Inches	(mm)
0.40	(10.2)	0.00	(0.0)
0.38	(9.7)	0.02	(0.5)
0.36	(9.1)	0.04	(1.0)
0.34	(8.6)	0.06	(1.5)
0.32	(8.1)	0.08	(2.0)
0.30	(7.6)	0.10	(2.5)
0.28	(7.1)	0.12	(3.0)
0.26	(6.6)	0.14	(3.5)
0.24	(6.1)	0.16	(4.0)
0.20	(5.6)	0.18	(4.5)
0.20	(5.1)	0.20	(5.0)
0.18	(4.6)	0.22	(5.5)
0.16	(4.1)	0.24	(6.0)
0.14	(3.6)	0.26	(6.5)
0.12	(3.0)	0.28	(7.0)
0.10	(2.5)	0.30	(7.5)
0.08	(2.0)	0.32	(8.0)
0.06	(1.5)	0.34	(8.5)
0.04	(1.0)	0.36	(9.0)
0.02	(0.5)	0.38	(9.5)

**NOTE**

Ultrasonic measurement is to determine flange wear only.

- 1 Flange width is 3.31 in. (84 mm)
- 2 New tread diameter is 21.26 in. (540 mm)
- 3 Wear Chart: 4361

**953 - 7.50 in. (190 mm)**

**Carrier Rollers<sup>(1)</sup>  
SystemOne Track**

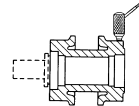
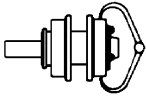

**Caliper  
All**

**Ultrasonic  
One-piece rim**

Inches	(mm)	% Worn	Inches	(mm)
7.16	(182.0)	0	1.96	(49.8)
7.10	(180.5)	4	1.93	(49.0)
7.04	(179.0)	8	1.90	(48.3)
6.98	(177.5)	12	1.87	(47.5)
6.92	(176.0)	16	1.84	(46.7)
6.86	(174.0)	20	1.81	(46.0)
6.80	(172.5)	24	1.78	(45.2)
6.74	(171.0)	28	1.75	(44.5)
6.68	(169.5)	32	1.72	(43.7)
6.62	(168.0)	36	1.69	(42.9)
6.56	(166.5)	40	1.66	(42.2)
6.50	(165.0)	44	1.63	(41.4)
6.44	(163.5)	48	1.60	(40.6)
6.38	(162.0)	52	1.57	(39.9)
6.32	(160.5)	56	1.54	(39.1)
6.26	(159.0)	60	1.51	(38.4)
6.20	(157.5)	64	1.48	(37.6)
6.14	(156.0)	68	1.45	(36.8)
6.08	(154.5)	72	1.42	(36.1)
6.02	(153.0)	76	1.39	(35.3)
5.96	(151.5)	80	1.36	(34.5)
5.90	(150.0)	84	1.33	(33.8)
5.84	(148.5)	88	1.30	(33.0)
5.78	(147.0)	91	1.27	(32.3)
5.72	(145.5)	94	1.24	(31.5)
5.66	(144.0)	97	1.21	(30.7)
5.60	(142.0)	100	1.18	(30.0)
5.54	(140.5)	103	1.15	(29.2)
5.48	(139.0)	106	1.12	(28.4)
5.42	(137.5)	109	1.09	(27.7)
5.36	(136.0)	112	1.06	(26.9)
5.30	(134.5)	115	1.03	(26.2)
5.24	(133.0)	118	1.00	(25.4)
5.18	(131.5)	121	0.97	(24.6)

1 Wear Chart: 4684

**Carrier Rollers <sup>(1)</sup>  
Conventional  
Use with 106-1625 & 26 Heavy Duty and RBT Links**

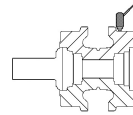
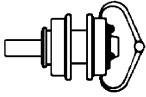

**Caliper  
All**

**Ultrasonic  
One-piece rim**

Inches	(mm)	% Worn	Inches	(mm)
6.75	(171.5)	0	1.55	(39.4)
6.67	(169.5)	6	1.51	(38.4)
6.59	(167.5)	12	1.47	(37.3)
6.51	(165.5)	18	1.43	(36.3)
6.43	(163.5)	24	1.39	(35.3)
6.35	(161.5)	30	1.35	(34.3)
6.27	(159.5)	36	1.31	(33.3)
6.19	(157.0)	42	1.27	(32.3)
6.11	(155.0)	48	1.23	(31.2)
6.03	(153.0)	54	1.19	(30.2)
5.95	(151.0)	60	1.15	(29.2)
5.87	(149.0)	66	1.11	(28.2)
5.79	(147.0)	72	1.07	(27.2)
5.71	(145.0)	76	1.03	(26.2)
5.63	(143.0)	80	0.99	(25.1)
5.55	(141.0)	84	0.95	(24.1)
5.47	(139.0)	88	0.91	(23.1)
5.39	(137.0)	92	0.87	(22.1)
5.31	(135.0)	96	0.83	(21.1)
5.23	(133.0)	100	0.79	(20.1)
5.15	(131.0)	104	0.75	(19.1)
5.07	(129.0)	108	0.71	(18.0)
4.99	(126.5)	112	0.67	(17.0)
4.91	(124.5)	116	0.63	(16.0)
4.83	(122.5)	120	0.59	(15.0)

**953 - 7.50 in. (190 mm)**

**Carrier Rollers<sup>(1)</sup>**  
**Conventional**  
 Use with 229-6909 & 10 Enhanced SALT Links

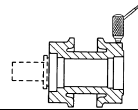
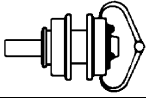

Caliper			Ultrasonic	
Inches	(mm)	% Worn	Inches	(mm)
6.75	(171.5)	0	1.55	(39.4)
6.71	(170.5)	4	1.53	(38.9)
6.67	(169.5)	8	1.51	(38.4)
6.63	(168.5)	12	1.49	(37.8)
6.59	(167.5)	16	1.47	(37.3)
6.55	(166.5)	20	1.45	(36.8)
6.51	(165.5)	24	1.43	(36.3)
6.47	(164.5)	28	1.41	(35.8)
6.43	(163.5)	31	1.39	(35.3)
6.39	(162.5)	34	1.37	(34.8)
6.35	(161.5)	37	1.35	(34.3)
6.31	(160.5)	40	1.33	(33.8)
6.27	(159.5)	43	1.31	(33.3)
6.23	(158.0)	46	1.29	(32.8)
6.19	(157.0)	49	1.27	(32.3)
6.15	(156.0)	52	1.25	(31.8)
6.11	(155.0)	55	1.23	(31.2)
6.07	(154.0)	58	1.21	(30.7)
6.03	(153.0)	61	1.19	(30.2)
5.99	(152.0)	64	1.17	(29.7)
5.95	(151.0)	67	1.15	(29.2)
5.91	(150.0)	70	1.13	(28.7)
5.87	(149.0)	73	1.11	(28.2)
5.83	(148.0)	76	1.09	(27.7)
5.79	(147.0)	79	1.07	(27.2)
5.75	(146.0)	82	1.05	(26.7)
5.71	(145.0)	85	1.03	(26.2)
5.67	(144.0)	88	1.01	(25.7)
5.63	(143.0)	91	0.99	(25.1)
5.59	(142.0)	94	0.97	(24.6)
5.55	(141.0)	97	0.95	(24.1)
5.51	(140.0)	100	0.93	(23.6)
5.47	(139.0)	103	0.91	(23.1)
5.43	(138.0)	106	0.89	(22.6)
5.39	(137.0)	109	0.87	(22.1)
5.35	(136.0)	112	0.85	(21.6)
5.31	(135.0)	115	0.83	(21.1)
5.27	(134.0)	118	0.81	(20.6)
5.23	(133.0)	121	0.79	(20.1)



Track Rollers <sup>(1)</sup>  
SystemOne™

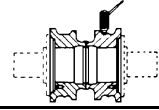
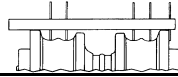

Caliper			Depth Gauge		Ultrasonic	
Inches	(mm)	% Worn	Inches	(mm)	Inches	(mm)
7.77	(197.5)	0	0.83	(21.0)	1.76	(44.7)
7.71	(196.0)	5	0.86	(22.0)	1.73	(43.9)
7.65	(194.5)	10	0.89	(22.5)	1.70	(43.2)
7.59	(193.0)	15	0.92	(23.5)	1.67	(42.4)
7.53	(191.5)	20	0.95	(24.0)	1.64	(41.7)
7.47	(189.5)	25	0.98	(25.0)	1.61	(40.9)
7.41	(188.0)	30	1.01	(25.5)	1.58	(40.1)
7.35	(186.5)	35	1.04	(26.5)	1.55	(39.4)
7.29	(185.0)	40	1.07	(27.0)	1.52	(38.6)
7.23	(183.5)	44	1.10	(28.0)	1.49	(37.8)
7.17	(182.0)	48	1.13	(28.5)	1.46	(37.1)
7.11	(180.5)	52	1.16	(29.5)	1.43	(36.3)
7.05	(179.0)	56	1.19	(30.0)	1.40	(35.6)
6.99	(177.5)	60	1.22	(31.0)	1.37	(34.8)
6.93	(176.0)	64	1.25	(32.0)	1.34	(34.0)
6.87	(174.5)	68	1.28	(32.5)	1.31	(33.3)
6.81	(173.0)	72	1.31	(33.5)	1.28	(32.5)
6.75	(171.5)	76	1.34	(34.0)	1.25	(31.8)
6.69	(170.0)	80	1.37	(35.0)	1.22	(31.0)
6.63	(168.5)	84	1.40	(35.5)	1.19	(30.2)
6.57	(167.0)	88	1.43	(36.5)	1.16	(29.5)
6.51	(165.5)	92	1.46	(37.0)	1.13	(28.7)
6.45	(164.0)	96	1.49	(38.0)	1.10	(27.9)
6.39	(162.5)	100	1.52	(38.5)	1.07	(27.2)
6.33	(161.0)	104	1.55	(39.5)	1.04	(26.4)
6.27	(159.5)	108	1.58	(40.0)	1.01	(25.7)
6.21	(157.5)	112	1.61	(41.0)	0.98	(24.9)
6.15	(156.0)	116	1.64	(41.5)	0.95	(24.1)
6.09	(154.5)	120	1.67	(42.5)	0.92	(23.4)

# 953 - 7.50 in. (190 mm)

## Track Rollers <sup>(1) (2)</sup> Conventional

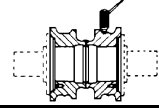
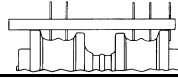
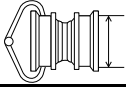

Caliper		% Worn	Depth Gauge		Ultrasonic	
Inches	(mm)		Inches	(mm)	Inches	(mm)
7.77	(197.5)	0	0.59	(15.0)	1.76	(44.7)
7.71	(196.0)	5	0.62	(15.5)	1.73	(43.9)
7.65	(194.5)	10	0.65	(16.5)	1.70	(43.2)
7.59	(193.0)	15	0.68	(17.5)	1.67	(42.4)
7.53	(191.5)	20	0.71	(18.0)	1.64	(41.7)
7.47	(189.5)	25	0.74	(19.0)	1.61	(40.9)
7.41	(188.0)	30	0.77	(19.5)	1.58	(40.1)
7.35	(186.5)	35	0.80	(20.5)	1.55	(39.4)
7.29	(185.0)	40	0.83	(21.0)	1.52	(38.6)
7.23	(183.5)	44	0.86	(22.0)	1.49	(37.8)
7.17	(182.0)	48	0.89	(22.5)	1.46	(37.1)
7.11	(180.5)	52	0.92	(23.5)	1.43	(36.3)
7.05	(179.0)	56	0.95	(24.0)	1.40	(35.6)
6.99	(177.5)	60	0.98	(25.0)	1.37	(34.8)
6.93	(176.0)	64	1.01	(25.5)	1.34	(34.0)
6.87	(174.5)	68	1.04	(26.5)	1.31	(33.3)
6.81	(173.0)	72	1.07	(27.0)	1.28	(32.5)
6.75	(171.5)	76	1.10	(28.0)	1.25	(31.8)
6.69	(170.0)	80	1.13	(28.5)	1.22	(31.0)
6.63	(168.5)	84	1.16	(29.5)	1.19	(30.2)
6.57	(167.0)	88	1.19	(30.0)	1.16	(29.5)
6.51	(165.5)	92	1.22	(31.0)	1.13	(28.7)
6.45	(164.0)	96	1.25	(32.0)	1.10	(27.9)
6.39	(162.5)	100	1.28	(32.5)	1.07	(27.2)
6.33	(161.0)	104	1.31	(33.5)	1.04	(26.4)
6.27	(159.5)	108	1.34	(34.0)	1.01	(25.7)
6.21	(157.5)	112	1.37	(35.0)	0.98	(24.9)
6.15	(156.0)	116	1.40	(35.5)	0.95	(24.1)
6.09	(154.5)	120	1.43	(36.5)	0.92	(23.4)

1 Flange diameter is 8.94 in. (227 mm)

2 Wear Chart: 5291

**Tall Flange Track Rollers <sup>(1)</sup> <sup>(2)</sup>**  
**Tall Flange Double Flange Rollers**

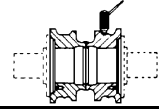

Caliper		% Worn	Depth Gauge		Ultrasonic	
Inches	(mm)		Inches	(mm)	Inches	(mm)
7.77	(197.5)	0	0.77	(19.5)	1.76	(44.7)
7.73	(196.5)	4	0.79	(20.0)	1.74	(44.2)
7.69	(195.5)	8	0.81	(20.5)	1.72	(43.7)
7.65	(194.5)	12	0.83	(21.0)	1.70	(43.2)
7.61	(193.5)	16	0.85	(21.5)	1.68	(42.7)
7.57	(192.5)	20	0.87	(22.0)	1.66	(42.2)
7.53	(191.5)	24	0.89	(22.5)	1.64	(41.7)
7.49	(190.0)	28	0.91	(23.0)	1.62	(41.1)
7.45	(189.0)	32	0.93	(23.5)	1.60	(40.6)
7.41	(188.0)	36	0.95	(24.0)	1.58	(40.1)
7.37	(187.0)	40	0.97	(24.5)	1.56	(39.6)
7.33	(186.0)	44	0.99	(25.0)	1.54	(39.1)
7.29	(185.0)	48	1.01	(25.5)	1.52	(38.6)
7.25	(184.0)	52	1.03	(26.0)	1.50	(38.1)
7.21	(183.0)	56	1.05	(26.5)	1.48	(37.6)
7.17	(182.0)	60	1.07	(27.0)	1.46	(37.1)
7.13	(181.0)	64	1.09	(27.5)	1.44	(36.6)
7.09	(180.0)	68	1.11	(28.0)	1.42	(36.1)
7.05	(179.0)	72	1.13	(28.5)	1.40	(35.6)
7.01	(178.0)	76	1.15	(29.0)	1.38	(35.1)
6.97	(177.0)	80	1.17	(29.5)	1.36	(34.5)
6.93	(176.0)	84	1.19	(30.0)	1.34	(34.0)
6.89	(175.0)	88	1.21	(30.5)	1.32	(33.5)
6.85	(174.0)	92	1.23	(31.0)	1.30	(33.0)
6.81	(173.0)	96	1.25	(32.0)	1.28	(32.5)
6.77	(172.0)	100	1.27	(32.5)	1.26	(32.0)
6.73	(171.0)	103	1.29	(33.0)	1.24	(31.5)
6.69	(170.0)	106	1.31	(33.5)	1.22	(31.0)
6.65	(169.0)	109	1.33	(34.0)	1.20	(30.5)
6.61	(168.0)	112	1.35	(34.5)	1.18	(30.0)
6.57	(167.0)	115	1.37	(35.0)	1.16	(29.5)
6.53	(166.0)	118	1.39	(35.5)	1.14	(29.0)
6.49	(165.0)	121	1.41	(36.0)	1.12	(28.4)

1 Flange diameter is 9.33 in. (237 mm)  
 2 Wear Chart: 6181

**953 - 6.91 in. (175.5 mm)**

**Track Links <sup>(1)</sup>  
7T-4539 & 40**

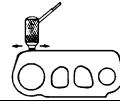
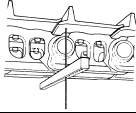

Depth Gauge			Ultrasonic	
Inches	(mm)	% Worn	Inches	(mm)
4.29	(109.0)	0	1.45	(36.8)
4.27	(108.5)	5	1.43	(36.3)
4.25	(108.0)	10	1.41	(35.8)
4.23	(107.5)	15	1.39	(35.3)
4.21	(107.0)	20	1.37	(34.8)
4.19	(106.5)	25	1.35	(34.3)
4.17	(106.0)	30	1.33	(33.8)
4.15	(105.5)	35	1.31	(33.3)
4.13	(105.0)	40	1.29	(32.8)
4.11	(104.5)	45	1.27	(32.3)
4.09	(104.0)	50	1.25	(31.8)
4.07	(103.5)	55	1.23	(31.2)
4.05	(103.0)	60	1.21	(30.7)
4.03	(102.5)	65	1.19	(30.2)
4.01	(102.0)	70	1.17	(29.7)
3.99	(101.5)	75	1.15	(29.2)
3.97	(101.0)	80	1.13	(28.7)
3.95	(100.5)	84	1.11	(28.2)
3.93	(100.0)	88	1.09	(27.7)
3.91	(99.5)	92	1.07	(27.2)
3.89	(99.0)	96	1.05	(26.7)
3.87	(98.5)	100	1.03	(26.2)
3.85	(98.0)	104	1.01	(25.7)
3.83	(97.5)	108	0.99	(25.1)
3.81	(97.0)	112	0.97	(24.6)
3.79	(96.5)	116	0.95	(24.1)
3.77	(96.0)	120	0.93	(23.6)

**Bushings <sup>(1)</sup>  
External Wear  
Sealed & Lubricated Track**

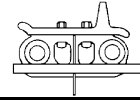
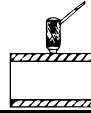

Caliper		Allowable Wear		Ultrasonic		Depth Gauge	
Inches	(mm)	Lesser % Worn	Greater % Worn	Inches	(mm)	Inches	(mm)
2.44	(62.0)	0	0	0.48	(12.2)	2.90	(73.7)
2.42	(61.5)	10	8	0.46	(11.7)	2.88	(73.2)
2.40	(61.0)	20	16	0.44	(11.2)	2.86	(72.6)
2.38	(60.5)	30	24	0.42	(10.7)	2.84	(72.1)
2.36	(59.9)	40	32	0.40	(10.2)	2.82	(71.6)
2.34	(59.4)	50	40	0.38	(9.7)	2.80	(71.1)
2.32	(58.9)	60	48	0.36	(9.1)	2.78	(70.6)
2.30	(58.4)	70	56	0.34	(8.6)	2.76	(70.1)
2.28	(57.9)	76	64	0.32	(8.1)	2.74	(69.6)
2.26	(57.4)	82	68	0.30	(7.6)	2.72	(69.1)
2.24	(56.9)	88	72	0.28	(7.1)	2.70	(68.6)
2.22	(56.4)	94	76	0.26	(6.6)	2.68	(68.1)
2.20	(55.9)	100	80	0.24	(6.1)	2.66	(67.6)
2.18	(55.4)	106	84	0.22	(5.6)	2.64	(67.1)
2.16	(54.9)	112	88	0.20	(5.1)	2.62	(66.5)
2.14	(54.4)	118	92	0.18	(4.6)	2.60	(66.0)
2.12	(53.8)	124	96	0.16	(4.1)	2.58	(65.5)
2.10	(53.3)		100	0.14	(3.6)	2.56	(65.0)
2.08	(52.8)		104	0.12	(3.0)	2.54	(64.5)
2.06	(52.3)		108	0.10	(2.5)	2.52	(64.0)
2.04	(51.8)		112	0.08	(2.0)	2.50	(63.5)
2.02	(51.3)		116	0.06	(1.5)	2.48	(63.0)
2.00	(50.8)		120	0.04	(1.0)	2.46	(62.5)

**Note: Do Not Use Depth Gauge Until Bushings Have Been "Turned."**

**953 - 6.91 in. (175.5 mm)**

**Track Shoes <sup>(1)</sup>  
Moderate Service**

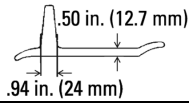
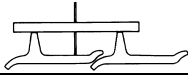

**Depth Gauge**

**Ultrasonic**

Depth Gauge		% Worn	Ultrasonic	
Inches	(mm)		Inches	(mm)
2.25	(57.0)	0	2.75	(69.9)
2.20	(56.0)	4	2.70	(68.6)
2.15	(54.5)	8	2.65	(67.3)
2.10	(53.5)	12	2.60	(66.0)
2.05	(52.0)	16	2.55	(64.8)
2.00	(51.0)	20	2.50	(63.5)
1.95	(49.5)	24	2.45	(62.2)
1.90	(48.5)	28	2.40	(61.0)
1.85	(47.0)	32	2.35	(59.7)
1.80	(45.5)	36	2.30	(58.4)
1.75	(44.5)	40	2.25	(57.2)
1.70	(43.0)	44	2.20	(55.9)
1.65	(42.0)	48	2.15	(54.6)
1.60	(40.5)	52	2.10	(53.3)
1.55	(39.5)	56	2.05	(52.1)
1.50	(38.0)	60	2.00	(50.8)
1.45	(37.0)	64	1.95	(49.5)
1.40	(35.5)	67	1.90	(48.3)
1.35	(34.5)	70	1.85	(47.0)
1.30	(33.0)	73	1.80	(45.7)
1.25	(32.0)	76	1.75	(44.5)
1.20	(30.5)	79	1.70	(43.2)
1.15	(29.0)	82	1.65	(41.9)
1.10	(28.0)	85	1.60	(40.6)
1.05	(26.5)	88	1.55	(39.4)
1.00	(25.5)	91	1.50	(38.1)
0.95	(24.0)	94	1.45	(36.8)
0.90	(23.0)	97	1.40	(35.6)
0.85	(21.5)	100	1.35	(34.3)
0.80	(20.5)	103	1.30	(33.0)
0.75	(19.0)	106	1.25	(31.8)
0.70	(18.0)	109	1.20	(30.5)
0.65	(16.5)	112	1.15	(29.2)
0.60	(15.0)	115	1.10	(27.9)
0.55	(14.0)	118	1.05	(26.7)
0.50	(12.5)	121	1.00	(25.4)

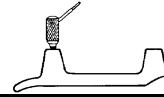
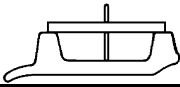
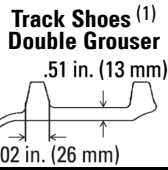

**Depth Gauge**

**Ultrasonic**

<b>Inches</b>	<b>(mm)</b>	<b>% Worn</b>	<b>Inches</b>	<b>(mm)</b>
1.50	(38.0)	0	1.99	(50.5)
1.45	(37.0)	5	1.94	(49.2)
1.40	(35.5)	10	1.89	(48.0)
1.35	(34.5)	15	1.84	(46.7)
1.30	(33.0)	20	1.79	(45.4)
1.25	(32.0)	25	1.74	(44.2)
1.20	(30.5)	30	1.69	(42.9)
1.15	(29.0)	35	1.64	(41.6)
1.10	(28.0)	40	1.59	(40.3)
1.05	(26.5)	45	1.54	(39.1)
1.00	(25.5)	50	1.49	(37.8)
0.95	(24.0)	55	1.44	(36.5)
0.90	(23.0)	60	1.39	(35.3)
0.85	(21.5)	65	1.34	(34.0)
0.80	(20.5)	70	1.29	(32.7)
0.75	(19.0)	75	1.24	(31.5)
0.70	(18.0)	80	1.19	(30.2)
0.65	(16.5)	85	1.14	(28.9)
0.60	(15.0)	90	1.09	(27.6)
0.55	(14.0)	95	1.04	(26.4)
0.50	(12.5)	100	0.99	(25.1)
0.45	(11.5)	105	0.94	(23.8)
0.40	(10.0)	110	0.89	(22.6)
0.35	(9.0)	115	0.84	(21.3)
0.30	(7.5)	120	0.79	(20.0)

**953 - 6.91 in. (175.5 mm)**

**Track Shoes <sup>(1)</sup>  
Triple Grouser**

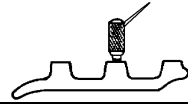
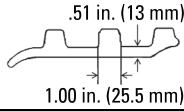
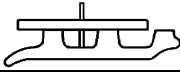

**Depth Gauge**

**Ultrasonic**

Depth Gauge		% Worn	Ultrasonic	
Inches	(mm)		Inches	(mm)
0.95	(24.0)	0	1.50	(38.1)
0.90	(23.0)	8	1.45	(36.8)
0.85	(21.5)	16	1.40	(35.6)
0.80	(20.5)	23	1.35	(34.3)
0.75	(19.0)	30	1.30	(33.0)
0.70	(18.0)	37	1.25	(31.8)
0.65	(16.5)	44	1.20	(30.5)
0.60	(15.0)	51	1.15	(29.2)
0.55	(14.0)	58	1.10	(27.9)
0.50	(12.5)	65	1.05	(26.7)
0.45	(11.5)	72	1.00	(25.4)
0.40	(10.0)	79	0.95	(24.1)
0.35	(9.0)	86	0.90	(22.9)
0.30	(7.5)	93	0.85	(21.6)
0.25	(6.5)	100	0.80	(20.3)
0.20	(5.0)	107	0.75	(19.1)
0.15	(4.0)	114	0.70	(17.8)
0.10	(2.5)	121	0.65	(16.5)



**Track Shoes <sup>(1)</sup>**  
**Rubber Grouser**

<b>Depth Gauge</b>		
<b>Inches</b>	<b>(mm)</b>	<b>% Worn</b>
2.55	(65.0)	0
2.50	(63.5)	10
2.45	(62.0)	20
2.40	(61.0)	30
2.35	(59.5)	40
2.30	(58.5)	50
2.25	(57.0)	60
2.20	(56.0)	70
2.15	(54.5)	80
2.10	(53.5)	90
2.05	(52.0)	100
2.00	(51.0)	110
1.95	(49.5)	120

# 953 - 6.91 in. (175.5 mm)

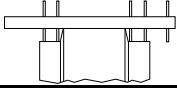

Depth Gauge		
Inches	(mm)	% Worn
0.74	(19.0)	0
0.76	(19.5)	7
0.78	(20.0)	14
0.80	(20.5)	21
0.82	(21.0)	28
0.84	(21.5)	35
0.86	(22.0)	42
0.88	(22.5)	49
0.90	(23.0)	56
0.92	(23.5)	63
0.94	(24.0)	67
0.96	(24.5)	70
0.98	(25.0)	73
1.00	(25.5)	76
1.02	(26.0)	79
1.04	(26.5)	82
1.06	(27.0)	85
1.08	(27.5)	88
1.10	(28.0)	91
1.12	(28.5)	94
1.14	(29.0)	97
1.16	(29.5)	100
1.18	(30.0)	103
1.20	(30.5)	106
1.22	(31.0)	109
1.24	(31.5)	112
1.26	(32.0)	115
1.28	(32.5)	118
1.30	(33.0)	121

## Idlers <sup>(1)</sup> <sup>(2)</sup> <sup>(3)</sup>

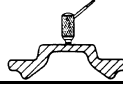

Ultrasonic		Center Flange Wear	
Inches	(mm)	Inches	(mm)
0.40	(10.2)	0.00	(0.0)
0.38	(9.7)	0.02	(0.5)
0.36	(9.1)	0.04	(1.0)
0.34	(8.6)	0.06	(1.5)
0.32	(8.1)	0.08	(2.0)
0.30	(7.6)	0.10	(2.5)
0.28	(7.1)	0.12	(3.0)
0.26	(6.6)	0.14	(3.5)
0.24	(6.1)	0.16	(4.0)
0.22	(5.6)	0.18	(4.5)
0.20	(5.1)	0.20	(5.0)
0.18	(4.6)	0.22	(5.5)
0.16	(4.1)	0.24	(6.0)
0.14	(3.6)	0.26	(6.5)
0.1	(3.0)	0.28	(7.0)
0.10	(2.5)	0.30	(7.5)
0.08	(2.0)	0.32	(8.0)
0.06	(1.5)	0.34	(8.5)
0.04	(1.0)	0.36	(9.0)
0.02	(0.5)	0.38	(9.5)

### NOTE

Ultrasonic measurement is to determine flange wear only.

- 1 Flange width is 3.31 in. (84 mm)
- 2 New tread diameter is 21.26 in. (540 mm)
- 3 Wear Chart: 4361

Carrier Rollers <sup>(1)</sup>

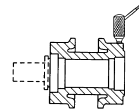
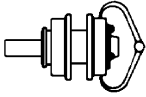

Caliper

Ultrasonic

Inches	(mm)	% Worn	Inches	(mm)
6.75	(171.5)	0	1.55	(39.4)
6.71	(170.5)	4	1.53	(38.9)
6.67	(169.5)	8	1.51	(38.3)
6.63	(168.5)	12	1.49	(37.8)
6.59	(167.5)	16	1.47	(37.3)
6.55	(166.5)	20	1.45	(36.8)
6.51	(165.5)	24	1.43	(36.3)
6.47	(164.5)	28	1.41	(35.8)
6.43	(163.5)	31	1.39	(35.3)
6.39	(162.5)	34	1.37	(34.8)
6.35	(161.5)	37	1.35	(34.3)
6.31	(160.5)	40	1.33	(33.8)
6.27	(159.5)	43	1.31	(33.3)
6.23	(158.0)	46	1.29	(32.8)
6.19	(157.0)	49	1.27	(32.3)
6.15	(156.0)	52	1.25	(31.8)
6.11	(155.0)	55	1.23	(31.2)
6.07	(154.0)	58	1.21	(30.7)
6.03	(153.0)	61	1.19	(30.2)
5.99	(152.0)	64	1.17	(29.7)
5.95	(151.0)	67	1.15	(29.2)
5.91	(150.0)	70	1.13	(28.7)
5.87	(149.0)	73	1.11	(28.2)
5.83	(148.0)	76	1.09	(27.7)
5.79	(147.0)	79	1.07	(27.2)
5.75	(146.0)	82	1.05	(26.7)
5.71	(145.0)	85	1.03	(26.2)
5.67	(144.0)	88	1.01	(25.7)
5.63	(143.0)	91	0.99	(25.1)
5.59	(142.0)	94	0.97	(24.6)
5.55	(141.0)	97	0.95	(24.1)
5.51	(140.0)	100	0.93	(23.6)
5.47	(139.0)	103	0.91	(23.1)
5.43	(138.0)	106	0.89	(22.6)
5.39	(137.0)	109	0.87	(22.1)
5.35	(136.0)	112	0.85	(21.6)
5.31	(135.0)	115	0.83	(21.1)
5.27	(134.0)	118	0.81	(20.6)
5.23	(133.0)	121	0.79	(20.1)

# 953 - 6.91 in. (175.5 mm)

## Track Rollers <sup>(1) (2)</sup> Rollers with End Collars

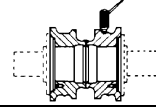
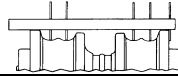

Caliper		% Worn	Depth Gauge		Ultrasonic	
Inches	(mm)		Inches	(mm)	Inches	(mm)
7.77	(197.5)	0	0.59	(15.0)	1.76	(44.7)
7.71	(196.0)	5	0.62	(15.5)	1.73	(43.9)
7.65	(194.5)	10	0.65	(16.5)	1.70	(43.2)
7.59	(193.0)	15	0.68	(17.5)	1.67	(42.4)
7.53	(191.5)	20	0.71	(18.0)	1.64	(41.7)
7.47	(189.5)	25	0.74	(19.0)	1.61	(40.9)
7.41	(188.0)	30	0.77	(19.5)	1.58	(40.1)
7.35	(186.5)	35	0.80	(20.5)	1.55	(39.4)
7.29	(185.0)	40	0.83	(21.0)	1.52	(38.6)
7.23	(183.5)	44	0.86	(22.0)	1.49	(37.8)
7.17	(182.0)	48	0.89	(22.5)	1.46	(37.1)
7.11	(180.5)	52	0.92	(23.5)	1.43	(36.3)
7.05	(179.0)	56	0.95	(24.0)	1.40	(35.6)
6.99	(177.5)	60	0.98	(25.0)	1.37	(34.8)
6.93	(176.0)	64	1.01	(25.5)	1.34	(34.0)
6.87	(174.5)	68	1.04	(26.5)	1.31	(33.3)
6.81	(173.0)	72	1.07	(27.0)	1.28	(32.5)
6.75	(171.5)	76	1.10	(28.0)	1.25	(31.8)
6.69	(170.0)	80	1.13	(28.5)	1.22	(31.0)
6.63	(168.5)	84	1.16	(29.5)	1.19	(30.2)
6.57	(167.0)	88	1.19	(30.0)	1.16	(29.5)
6.51	(165.5)	92	1.22	(31.0)	1.13	(28.7)
6.45	(164.0)	96	1.25	(32.0)	1.10	(27.9)
6.39	(162.5)	100	1.28	(32.5)	1.07	(27.2)
6.33	(161.0)	104	1.31	(33.5)	1.04	(26.4)
6.27	(159.5)	108	1.34	(34.0)	1.01	(25.7)
6.21	(157.5)	112	1.37	(35.0)	0.98	(24.9)
6.15	(156.0)	116	1.40	(35.5)	0.95	(24.1)
6.09	(154.5)	120	1.43	(36.5)	0.92	(23.4)

1 Flange diameter is 8.94 in. (227 mm)

2 Wear Chart: 5291

**Track Rollers <sup>(1) (2)</sup>  
Rollers with Retainers**

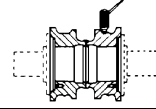

Caliper		% Worn	Depth Gauge		Ultrasonic	
Inches	(mm)		Inches	(mm)	Inches	(mm)
7.77	(197.5)	0	0.58	(14.5)	1.87	(47.5)
7.71	(196.0)	5	0.61	(15.5)	1.84	(46.7)
7.65	(194.5)	10	0.64	(16.5)	1.81	(46.0)
7.59	(193.0)	15	0.67	(17.0)	1.78	(45.2)
7.53	(191.5)	20	0.70	(18.0)	1.75	(44.5)
7.47	(189.5)	25	0.73	(18.5)	1.72	(43.7)
7.41	(188.0)	30	0.76	(19.5)	1.69	(42.9)
7.35	(186.5)	35	0.79	(20.0)	1.66	(42.2)
7.29	(185.0)	40	0.82	(21.0)	1.63	(41.4)
7.23	(183.5)	44	0.85	(21.5)	1.60	(40.6)
7.17	(182.0)	48	0.88	(22.5)	1.57	(39.9)
7.11	(180.5)	52	0.91	(23.0)	1.54	(39.1)
7.05	(179.0)	56	0.94	(24.0)	1.51	(38.4)
6.99	(177.5)	60	0.97	(24.5)	1.48	(37.6)
6.93	(176.0)	64	1.00	(25.5)	1.45	(36.8)
6.87	(174.5)	68	1.03	(26.0)	1.42	(36.1)
6.81	(173.0)	72	1.06	(27.0)	1.39	(35.3)
6.75	(171.5)	76	1.09	(27.5)	1.36	(34.5)
6.69	(170.0)	80	1.12	(28.5)	1.33	(33.8)
6.63	(168.5)	84	1.15	(29.0)	1.30	(33.0)
6.57	(167.0)	88	1.18	(30.0)	1.27	(32.3)
6.51	(165.5)	92	1.21	(30.5)	1.24	(31.5)
6.45	(164.0)	96	1.24	(31.5)	1.21	(30.7)
6.39	(162.5)	100	1.27	(32.5)	1.18	(30.0)
6.33	(161.0)	104	1.30	(33.0)	1.15	(29.2)
6.27	(159.5)	108	1.33	(34.0)	1.12	(28.4)
6.21	(157.5)	112	1.36	(34.5)	1.09	(27.7)
6.15	(156.0)	116	1.39	(35.5)	1.06	(26.9)
6.09	(154.5)	120	1.42	(36.0)	1.03	(26.2)

1 Flange diameter is 8.94 in. (227 mm)  
 2 Wear Chart: 5262



Track Links <sup>(1)</sup>  
SystemOne Track  
234-9699

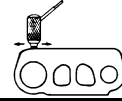
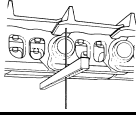

Depth Gauge			Ultrasonic	
Inches	(mm)	% Worn	Inches	(mm)
5.27	(134.0)	0	1.61	(40.9)
5.25	(133.5)	4	1.59	(40.4)
5.23	(133.0)	8	1.57	(39.9)
5.21	(132.5)	12	1.55	(39.4)
5.19	(132.0)	16	1.53	(38.9)
5.17	(131.5)	20	1.51	(38.4)
5.15	(131.0)	24	1.49	(37.8)
5.13	(130.5)	28	1.47	(37.3)
5.11	(130.0)	32	1.45	(36.8)
5.09	(129.5)	36	1.43	(36.3)
5.07	(129.0)	40	1.41	(35.8)
5.05	(128.5)	44	1.39	(35.3)
5.03	(128.0)	48	1.37	(34.8)
5.01	(127.5)	52	1.35	(34.3)
4.99	(126.5)	56	1.33	(33.8)
4.97	(126.0)	60	1.31	(33.3)
4.95	(125.5)	64	1.29	(32.8)
4.93	(125.0)	68	1.27	(32.3)
4.91	(124.5)	72	1.25	(31.8)
4.89	(124.0)	76	1.23	(31.2)
4.87	(123.5)	80	1.21	(30.7)
4.85	(123.0)	84	1.19	(30.2)
4.83	(122.5)	88	1.17	(29.7)
4.81	(122.0)	91	1.15	(29.2)
4.79	(121.5)	94	1.13	(28.7)
4.77	(121.0)	97	1.11	(28.2)
4.75	(120.5)	100	1.09	(27.7)
4.73	(120.0)	103	1.07	(27.2)
4.71	(119.5)	106	1.05	(26.7)
4.69	(119.0)	109	1.03	(26.2)
4.67	(118.5)	112	1.01	(25.7)
4.65	(118.0)	115	0.99	(25.1)
4.63	(117.5)	118	0.97	(24.6)
4.61	(117.0)	121	0.95	(24.1)

**963 - 8.00 in. (203.2 mm)**

**Track Links <sup>(1)</sup>  
Enhanced SALT Track  
228-2735-36**

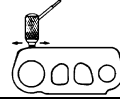
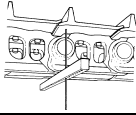

Depth Gauge			Ultrasonic	
Inches	(mm)	% Worn	Inches	(mm)
5.03	(128.0)	0	1.60	(40.6)
5.01	(127.5)	4	1.58	(40.1)
4.99	(126.5)	8	1.56	(39.6)
4.97	(126.0)	12	1.54	(39.1)
4.95	(125.5)	16	1.52	(38.6)
4.93	(125.0)	20	1.50	(38.1)
4.91	(124.5)	24	1.48	(37.6)
4.89	(124.0)	28	1.46	(37.1)
4.87	(123.5)	32	1.44	(36.6)
4.85	(123.0)	36	1.42	(36.1)
4.83	(122.5)	40	1.40	(35.6)
4.81	(122.0)	44	1.38	(35.1)
4.79	(121.5)	48	1.36	(34.5)
4.77	(121.0)	52	1.34	(34.0)
4.75	(120.5)	56	1.32	(33.5)
4.73	(120.0)	60	1.30	(33.0)
4.71	(119.5)	64	1.28	(32.5)
4.69	(119.0)	68	1.26	(32.0)
4.67	(118.5)	72	1.24	(31.5)
4.65	(118.0)	76	1.22	(31.0)
4.63	(117.5)	80	1.20	(30.5)
4.61	(117.0)	84	1.18	(30.0)
4.59	(116.5)	88	1.16	(29.5)
4.57	(116.0)	92	1.14	(29.0)
4.55	(115.5)	96	1.12	(28.4)
4.53	(115.0)	100	1.10	(27.9)
4.51	(114.5)	103	1.08	(27.4)
4.49	(114.0)	106	1.06	(26.9)
4.47	(113.5)	109	1.04	(26.4)
4.45	(113.0)	112	1.02	(25.9)
4.43	(112.5)	115	1.00	(25.4)
4.41	(112.0)	118	0.98	(24.9)
4.39	(111.5)	121	0.96	(24.4)



**Track Links <sup>(1)</sup>  
Rotating Bushing Track  
195-6515 & 16  
8E-7405 & 06  
165-1754 & 55**

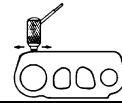
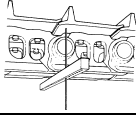

Depth Gauge			Ultrasonic	
Inches	(mm)	% Worn	Inches	(mm)
5.19	(132.0)	0	1.69	(42.9)
5.17	(131.5)	4	1.67	(42.4)
5.15	(131.0)	8	1.65	(41.9)
5.13	(130.5)	12	1.63	(41.4)
5.11	(130.0)	16	1.61	(40.9)
5.09	(129.5)	20	1.59	(40.4)
5.07	(129.0)	24	1.57	(39.9)
5.05	(128.5)	28	1.55	(39.4)
5.03	(128.0)	32	1.53	(38.9)
5.01	(127.5)	36	1.51	(38.4)
4.99	(126.5)	40	1.49	(37.8)
4.97	(126.0)	44	1.47	(37.3)
4.95	(125.5)	48	1.45	(36.8)
4.93	(125.0)	52	1.43	(36.3)
4.91	(124.5)	56	1.41	(35.8)
4.89	(124.0)	60	1.39	(35.3)
4.87	(123.5)	64	1.37	(34.8)
4.85	(123.0)	68	1.35	(34.3)
4.83	(122.5)	72	1.33	(33.8)
4.81	(122.0)	76	1.31	(33.3)
4.79	(121.5)	80	1.29	(32.8)
4.77	(121.0)	84	1.27	(32.3)
4.75	(120.5)	88	1.25	(31.8)
4.73	(120.0)	91	1.23	(31.2)
4.71	(119.5)	94	1.21	(30.7)
4.69	(119.0)	97	1.19	(30.2)
4.67	(118.5)	100	1.17	(29.7)
4.65	(118.0)	103	1.15	(29.2)
4.63	(117.5)	106	1.13	(28.7)
4.61	(117.0)	109	1.11	(28.2)
4.59	(116.5)	112	1.09	(27.7)
4.57	(116.0)	115	1.07	(27.2)
4.55	(115.5)	118	1.05	(26.7)
4.53	(115.0)	121	1.03	(26.2)

**963 - 8.00 in. (203.2 mm)**

**Track Links <sup>(1)</sup>  
Sealed & Lubricated Track  
7T-4645 & 46**

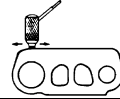
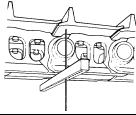

Depth Gauge			Ultrasonic	
Inches	(mm)	% Worn	Inches	(mm)
5.03	(128.0)	0	1.67	(42.4)
5.01	(127.5)	4	1.65	(41.9)
4.99	(126.5)	8	1.63	(41.4)
4.97	(126.0)	12	1.61	(40.9)
4.95	(125.5)	16	1.59	(40.4)
4.93	(125.0)	20	1.57	(39.9)
4.91	(124.5)	24	1.55	(39.4)
4.89	(124.0)	28	1.53	(38.9)
4.87	(123.5)	32	1.51	(38.4)
4.85	(123.0)	36	1.49	(37.8)
4.83	(122.5)	40	1.47	(37.3)
4.81	(122.0)	44	1.45	(36.8)
4.79	(121.5)	48	1.43	(36.3)
4.77	(121.0)	52	1.41	(35.8)
4.75	(120.5)	56	1.39	(35.3)
4.73	(120.0)	60	1.37	(34.8)
4.71	(119.5)	64	1.35	(34.3)
4.69	(119.0)	68	1.33	(33.8)
4.67	(118.5)	72	1.31	(33.3)
4.65	(118.0)	76	1.29	(32.8)
4.63	(117.5)	80	1.27	(32.3)
4.61	(117.0)	84	1.25	(31.8)
4.59	(116.5)	88	1.23	(31.2)
4.57	(116.0)	92	1.21	(30.7)
4.55	(115.5)	96	1.19	(30.2)
4.53	(115.0)	100	1.17	(29.7)
4.51	(114.5)	103	1.15	(29.2)
4.49	(114.0)	106	1.13	(28.7)
4.47	(113.5)	109	1.11	(28.2)
4.45	(113.0)	112	1.09	(27.7)
4.43	(112.5)	115	1.07	(27.2)
4.41	(112.0)	118	1.05	(26.7)
4.39	(111.5)	121	1.03	(26.2)

**Bushings<sup>(1)</sup>**  
**External Wear**  
**SystemOne Track**

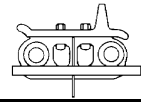
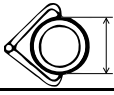

Caliper			Ultrasonic		Depth Gauge	
Inches	(mm)	% Worn	Inches	(mm)	Inches	(mm)
2.86	(72.6)	0	0.55	(14.0)	3.63	(92.2)
2.84	(72.1)	6	0.54	(13.7)	3.62	(91.9)
2.82	(71.6)	12	0.53	(13.5)	3.61	(91.7)
2.80	(71.1)	18	0.52	(13.2)	3.60	(91.4)
2.78	(70.6)	24	0.51	(13.0)	3.59	(91.2)
2.76	(70.1)	30	0.50	(12.7)	3.58	(90.9)
2.74	(69.6)	36	0.49	(12.4)	3.57	(90.7)
2.72	(69.1)	42	0.48	(12.2)	3.56	(90.4)
2.70	(68.6)	46	0.47	(11.9)	3.55	(90.2)
2.68	(68.1)	49	0.46	(11.7)	3.54	(89.9)
2.66	(67.6)	52	0.45	(11.4)	3.53	(89.7)
2.64	(67.1)	55	0.44	(11.2)	3.52	(89.4)
2.62	(66.5)	58	0.43	(10.9)	3.51	(89.2)
2.60	(66.0)	61	0.42	(10.7)	3.50	(88.9)
2.58	(65.5)	64	0.41	(10.4)	3.49	(88.6)
2.56	(65.0)	67	0.40	(10.2)	3.48	(88.4)
2.54	(64.5)	70	0.39	(9.9)	3.47	(88.1)
2.52	(64.0)	73	0.38	(9.7)	3.46	(87.9)
2.50	(63.5)	76	0.37	(9.4)	3.45	(87.6)
2.48	(63.0)	79	0.36	(9.1)	3.44	(87.4)
2.46	(62.5)	82	0.35	(8.9)	3.43	(87.1)
2.44	(62.0)	85	0.34	(8.6)	3.42	(86.9)
2.42	(61.5)	88	0.33	(8.4)	3.41	(86.6)
2.40	(61.0)	91	0.32	(8.1)	3.40	(86.4)
2.38	(60.5)	94	0.31	(7.9)	3.39	(86.1)
2.36	(59.9)	97	0.30	(7.6)	3.38	(85.9)
2.34	(59.4)	100	0.29	(7.4)	3.37	(85.6)
2.32	(58.9)	103	0.28	(7.1)	3.36	(85.3)
2.30	(58.4)	106	0.27	(6.9)	3.35	(85.1)
2.28	(57.9)	109	0.26	(6.6)	3.34	(84.8)
2.26	(57.4)	112	0.25	(6.3)	3.33	(84.6)
2.24	(56.9)	115	0.24	(6.1)	3.32	(84.3)
2.22	(56.4)	118	0.23	(5.8)	3.31	(84.1)
2.20	(55.9)	121	0.22	(5.6)	3.30	(83.8)

**963 - 8.00 in. (203.2 mm)**

**Bushings <sup>(1)</sup>  
External Wear  
Enhanced SALT Track  
Use with 228-2735-36 Links**

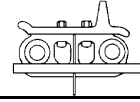
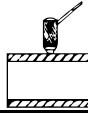
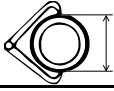

Caliper		Allowable Wear		Ultrasonic		Depth Gauge	
Inches	(mm)	Lesser % Worn	Greater % Worn	Inches	(mm)	Inches	(mm)
2.86	(72.6)	0	0	0.53	(13.5)	3.49	(88.6)
2.84	(72.1)	10	8	0.51	(13.0)	3.47	(88.1)
2.82	(71.6)	20	16	0.49	(12.4)	3.45	(87.6)
2.80	(71.1)	30	24	0.47	(11.9)	3.43	(87.1)
2.78	(70.6)	40	32	0.45	(11.4)	3.41	(86.6)
2.76	(70.1)	50	40	0.43	(10.9)	3.39	(86.1)
2.74	(69.6)	60	48	0.41	(10.4)	3.37	(85.6)
2.72	(69.1)	70	52	0.39	(9.9)	3.35	(85.1)
2.70	(68.6)	76	56	0.37	(9.4)	3.33	(84.6)
2.68	(68.1)	80	60	0.35	(8.9)	3.31	(84.1)
2.66	(67.6)	84	64	0.33	(8.4)	3.29	(83.6)
2.64	(67.1)	88	68	0.31	(7.9)	3.27	(83.1)
2.62	(66.5)	92	72	0.29	(7.4)	3.25	(82.6)
2.60	(66.0)	96	76	0.27	(6.9)	3.23	(82.0)
2.58	(65.5)	100	80	0.25	(6.3)	3.21	(81.5)
2.56	(65.0)	104	84	0.23	(5.8)	3.19	(81.0)
2.54	(64.5)	108	88	0.21	(5.3)	3.17	(80.5)
2.52	(64.0)	112	92	0.19	(4.8)	3.15	(80.0)
2.50	(63.5)	116	96	0.17	(4.3)	3.13	(79.5)
2.48	(63.0)	120	100	0.15	(3.8)	3.11	(79.0)
2.46	(62.5)		104	0.13	(3.3)	3.09	(78.5)
2.44	(62.0)		108	0.11	(2.8)	3.07	(78.0)
2.42	(61.5)		112	0.09	(2.3)	3.05	(77.5)
2.40	(61.0)		116	0.07	(1.8)	3.03	(77.0)
2.38	(60.5)		120	0.05	(1.3)	3.01	(76.5)

**Note: Do Not Use Depth Gauge Until Bushings Have Been "Turned."**

**Bushings <sup>(1)</sup>**  
**External Wear**  
**Rotating Bushing Track**  
 Use with 8E, 195-6515 & 16 or 165-1754 & 55 Links

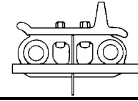
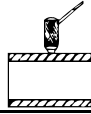

Caliper			Ultrasonic		Depth Gauge	
Inches	(mm)	% Worn	Inches	(mm)	Inches	(mm)
2.86	(72.6)	0	0.55	(14.0)	3.56	(90.4)
2.82	(71.6)	8	0.53	(13.5)	3.54	(89.9)
2.78	(70.6)	16	0.51	(13.0)	3.52	(89.4)
2.74	(69.6)	24	0.49	(12.4)	3.50	(88.9)
2.70	(68.6)	32	0.47	(11.9)	3.48	(88.4)
2.66	(67.6)	40	0.45	(11.4)	3.46	(87.9)
2.62	(66.5)	44	0.43	(10.9)	3.44	(87.4)
2.58	(65.5)	48	0.41	(10.4)	3.42	(86.9)
2.54	(64.5)	52	0.39	(9.9)	3.40	(86.4)
2.50	(63.5)	56	0.37	(9.4)	3.38	(85.9)
2.46	(62.5)	60	0.35	(8.9)	3.36	(85.3)
2.42	(61.5)	64	0.33	(8.4)	3.34	(84.8)
2.38	(60.5)	68	0.31	(7.9)	3.32	(84.3)
2.34	(59.4)	72	0.29	(7.4)	3.30	(83.8)
2.30	(58.4)	76	0.27	(6.9)	3.28	(83.3)
2.26	(57.4)	80	0.25	(6.3)	3.26	(82.8)
2.22	(56.4)	84	0.23	(5.8)	3.24	(82.3)
2.18	(55.4)	88	0.21	(5.3)	3.22	(81.8)
2.14	(54.4)	92	0.19	(4.8)	3.20	(81.3)
2.10	(53.3)	96	0.17	(4.3)	3.18	(80.8)
2.06	(52.3)	100	0.15	(3.8)	3.16	(80.3)
2.02	(51.3)	104	0.13	(3.3)	3.14	(79.8)
1.98	(50.3)	108	0.11	(2.8)	3.12	(79.2)
1.94	(49.3)	112	0.09	(2.3)	3.10	(78.7)
1.90	(48.3)	116	0.07	(1.8)	3.08	(78.2)
1.86	(47.2)	120	0.05	(1.3)	3.06	(77.7)

**963 - 8.00 in. (203.2 mm)**

**Bushings <sup>(1)</sup>  
External Wear  
Sealed & Lubricated Track  
Use with 7T Links**

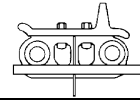
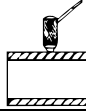

Caliper		Allowable Wear		Ultrasonic		Depth Gauge	
		Lesser % Worn	Greater % Worn				
Inches	(mm)			Inches	(mm)	Inches	(mm)
2.86	(72.6)	0	0	0.53	(13.5)	3.49	(88.6)
2.84	(72.1)	10	8	0.51	(13.0)	3.47	(88.1)
2.82	(71.6)	20	16	0.49	(12.4)	3.45	(87.6)
2.80	(71.1)	30	24	0.47	(11.9)	3.43	(87.1)
2.78	(70.6)	40	32	0.45	(11.4)	3.41	(86.6)
2.76	(70.1)	50	40	0.43	(10.9)	3.39	(86.1)
2.74	(69.6)	60	48	0.41	(10.4)	3.37	(85.6)
2.72	(69.1)	70	56	0.39	(9.9)	3.35	(85.1)
2.70	(68.6)	76	64	0.37	(9.4)	3.33	(84.6)
2.68	(68.1)	82	68	0.35	(8.9)	3.31	(84.1)
2.66	(67.6)	88	72	0.33	(8.4)	3.29	(83.6)
2.64	(67.1)	94	76	0.31	(7.9)	3.27	(83.1)
2.62	(66.5)	100	80	0.29	(7.4)	3.25	(82.6)
2.60	(66.0)	106	84	0.27	(6.9)	3.23	(82.0)
2.58	(65.5)	112	88	0.25	(6.3)	3.21	(81.5)
2.56	(65.0)	118	92	0.23	(5.8)	3.19	(81.0)
2.54	(64.5)	124	96	0.21	(5.3)	3.17	(80.5)
2.52	(64.0)		100	0.19	(4.8)	3.15	(80.0)
2.50	(63.5)		104	0.17	(4.3)	3.13	(79.5)
2.48	(63.0)		108	0.15	(3.8)	3.11	(79.0)
2.46	(62.5)		112	0.13	(3.3)	3.09	(78.5)
2.44	(62.0)		116	0.11	(2.8)	3.07	(78.0)
2.42	(61.5)		120	0.09	(2.3)	3.05	(77.5)

**Note: Do Not Use Depth Gauge Until Bushings Have Been "Turned."**

**Track Shoes <sup>(1)</sup>  
Extreme Service**

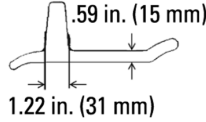
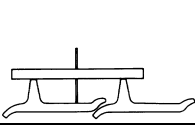

Depth Gauge		High Impact	Low/Moderate	Ultrasonic	
Inches	(mm)	% Worn	Impact % Worn	Inches	(mm)
2.95	(75.0)	0	0	3.55	(90.2)
2.85	(72.5)	8	6	3.45	(87.6)
2.75	(70.0)	16	12	3.35	(85.1)
2.65	(67.5)	24	18	3.25	(82.6)
2.55	(65.0)	32	24	3.15	(80.0)
2.45	(62.0)	40	30	3.05	(77.5)
2.35	(59.5)	48	36	2.95	(74.9)
2.30	(58.5)	52	39	2.90	(73.7)
2.20	(56.0)	58	45	2.80	(71.1)
2.10	(53.5)	64	51	2.70	(68.6)
2.00	(51.0)	70	57	2.60	(66.0)
1.90	(48.5)	76	63	2.50	(63.5)
1.80	(45.5)	82	68	2.40	(61.0)
1.70	(43.0)	88	72	2.30	(58.4)
1.60	(40.5)	94	76	2.20	(55.9)
1.50	(38.0)	100	80	2.10	(53.3)
1.40	(35.5)	106	84	2.00	(50.8)
1.30	(33.0)	112	88	1.90	(48.3)
1.20	(30.5)	118	92	1.80	(45.7)
1.10	(28.0)	124	96	1.70	(43.2)
1.00	(25.5)		100	1.60	(40.6)
0.90	(23.0)		104	1.50	(38.1)
0.80	(20.5)		108	1.40	(35.6)
0.70	(18.0)		112	1.30	(33.0)
0.60	(15.0)		116	1.20	(30.5)
0.50	(12.5)		120	1.10	(27.9)

**963 - 8.00 in. (203.2 mm)**

**Track Shoes <sup>(1)</sup>  
Moderate Service**

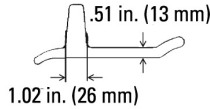
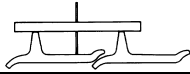

Depth Gauge		High Impact	Low/Moderate	Ultrasonic	
Inches	(mm)	% Worn	Impact % Worn	Inches	(mm)
2.55	(65.0)	0	0	3.05	(77.5)
2.50	(63.5)	5	4	3.00	(76.2)
2.45	(62.0)	10	8	2.95	(74.9)
2.40	(61.0)	15	12	2.90	(73.7)
2.35	(59.5)	20	16	2.85	(72.4)
2.30	(58.5)	25	20	2.80	(71.1)
2.25	(57.0)	30	24	2.75	(69.9)
2.20	(56.0)	35	28	2.70	(68.6)
2.15	(54.5)	40	31	2.65	(67.3)
2.10	(53.5)	45	34	2.60	(66.0)
2.05	(52.0)	50	37	2.55	(64.8)
2.00	(51.0)	55	40	2.50	(63.5)
1.95	(49.5)	60	43	2.45	(62.2)
1.90	(48.5)	65	46	2.40	(61.0)
1.85	(47.0)	70	49	2.35	(59.7)
1.80	(45.5)	75	52	2.30	(58.4)
1.75	(44.5)	80	55	2.25	(57.2)
1.70	(43.0)	84	58	2.20	(55.9)
1.65	(42.0)	88	61	2.15	(54.6)
1.60	(40.5)	92	64	2.10	(53.3)
1.55	(39.5)	96	67	2.05	(52.1)
1.50	(38.0)	100	70	2.00	(50.8)
1.45	(37.0)	104	73	1.95	(49.5)
1.40	(35.5)	108	76	1.90	(48.3)
1.35	(34.5)	112	79	1.85	(47.0)
1.30	(33.0)	116	82	1.80	(45.7)
1.25	(32.0)	120	85	1.75	(44.5)
1.20	(30.5)		88	1.70	(43.2)
1.15	(29.0)		91	1.65	(41.9)
1.10	(28.0)		94	1.60	(40.6)
1.05	(26.5)		97	1.55	(39.4)
1.00	(25.5)		100	1.50	(38.1)
0.95	(24.0)		103	1.45	(36.8)
0.90	(23.0)		106	1.40	(35.6)
0.85	(21.5)		109	1.35	(34.3)
0.80	(20.5)		112	1.30	(33.0)
0.75	(19.0)		115	1.25	(31.8)
0.70	(18.0)		118	1.20	(30.5)
0.65	(16.5)		121	1.15	(29.2)



**Track Shoes <sup>(1)</sup>  
Double Grouser**

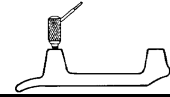
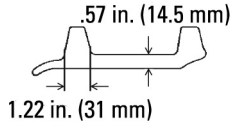
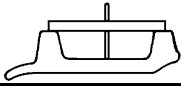

Depth Gauge		High Impact	Low/Moderate	Ultrasonic	
Inches	(mm)	% Worn	Impact % Worn	Inches	(mm)
1.65	(42.0)	0	0	2.20	(55.9)
1.60	(40.5)	6	5	2.15	(54.6)
1.55	(39.5)	12	10	2.10	(53.3)
1.50	(38.0)	18	15	2.05	(52.1)
1.45	(37.0)	24	20	2.00	(50.8)
1.40	(35.5)	30	25	1.95	(49.5)
1.35	(34.5)	36	30	1.90	(48.3)
1.30	(33.0)	42	35	1.85	(47.0)
1.25	(32.0)	48	40	1.80	(45.7)
1.20	(30.5)	54	44	1.75	(44.5)
1.15	(29.0)	60	48	1.70	(43.2)
1.10	(28.0)	65	52	1.65	(41.9)
1.05	(26.5)	70	56	1.60	(40.6)
1.00	(25.5)	75	60	1.55	(39.4)
0.95	(24.0)	80	64	1.50	(38.1)
0.90	(23.0)	85	68	1.45	(36.8)
0.85	(21.5)	90	72	1.40	(35.6)
0.80	(20.5)	95	76	1.35	(34.3)
0.75	(19.0)	100	80	1.30	(33.0)
0.70	(18.0)	105	84	1.25	(31.8)
0.65	(16.5)	110	88	1.20	(30.5)
0.60	(15.0)	115	92	1.15	(29.2)
0.55	(14.0)	120	96	1.10	(27.9)
0.50	(12.5)		100	1.05	(26.7)
0.45	(11.5)		104	1.00	(25.4)
0.40	(10.0)		108	0.95	(24.1)
0.35	(9.0)		112	0.90	(22.9)
0.30	(7.5)		116	0.85	(21.6)
0.25	(6.5)		120	0.80	(20.3)

**963 - 8.00 in. (203.2 mm)**

**Track Shoes <sup>(1)</sup>  
Triple Grouser**

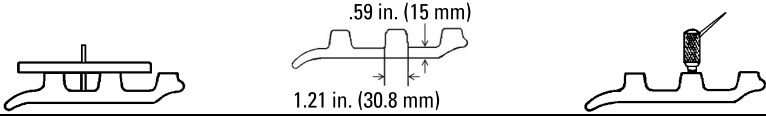

Depth Gauge			Ultrasonic	
Inches	(mm)	% Worn	Inches	(mm)
1.05	(26.5)	0	1.65	(41.9)
1.00	(25.5)	10	1.60	(40.6)
0.95	(24.0)	19	1.55	(39.4)
0.90	(23.0)	28	1.50	(38.1)
0.85	(21.5)	37	1.45	(36.8)
0.80	(20.5)	46	1.40	(35.6)
0.75	(19.0)	55	1.35	(34.3)
0.70	(18.0)	64	1.30	(33.0)
0.65	(16.5)	73	1.25	(31.8)
0.60	(15.0)	82	1.20	(30.5)
0.55	(14.0)	91	1.15	(29.2)
0.50	(12.5)	100	1.10	(27.9)
0.45	(11.5)	109	1.05	(26.7)
0.40	(10.0)	118	1.00	(25.4)
0.35	(9.0)	127	0.95	(24.1)

1 Wear Chart: 2800

**Track Shoes <sup>(1)</sup>  
Chopper**

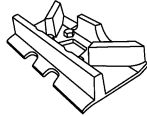

Depth Gauge			Ultrasonic	
Inches	(mm)	% Worn	Inches	(mm)
2.75	(70.0)	0	3.30	(83.8)
2.65	(67.5)	5	3.20	(81.3)
2.55	(65.0)	10	3.10	(78.7)
2.45	(62.0)	15	3.00	(76.2)
2.35	(59.5)	20	2.90	(73.7)
2.25	(57.0)	25	2.80	(71.1)
2.15	(54.5)	30	2.70	(68.6)
2.05	(52.0)	35	2.60	(66.0)
1.95	(49.5)	40	2.50	(63.5)
1.85	(47.0)	45	2.40	(61.0)
1.75	(44.5)	50	2.30	(58.4)
1.65	(42.0)	55	2.20	(55.9)
1.55	(39.5)	60	2.10	(53.3)
1.45	(37.0)	65	2.00	(50.8)
1.35	(34.5)	70	1.90	(48.3)
1.25	(31.5)	75	1.80	(45.7)
1.15	(29.0)	80	1.70	(43.2)
1.05	(26.5)	85	1.60	(40.6)
0.95	(24.0)	90	1.50	(38.1)
0.85	(21.5)	95	1.40	(35.6)
0.75	(19.0)	100	1.30	(33.0)
0.65	(16.5)	104	1.20	(30.5)
0.55	(14.0)	108	1.10	(27.9)
0.45	(11.5)	112	1.00	(25.4)
0.35	(9.0)	116	0.90	(22.9)
0.25	(6.5)	120	0.80	(20.3)

**Idlers <sup>(1)</sup> <sup>(2)</sup> <sup>(3)</sup>**  
**Center Tread Idler**

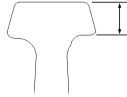

Ultrasonic, Depth Gauge or Caliper		
Inches	(mm)	% Worn
1.10	(28.0)	0
1.08	(27.5)	4
1.06	(27.0)	8
1.04	(26.5)	12
1.02	(26.0)	16
1.00	(25.5)	20
0.98	(25.0)	24
0.96	(24.5)	28
0.94	(24.0)	32
0.92	(23.5)	36
0.90	(23.0)	40
0.88	(22.5)	44
0.86	(22.0)	48
0.84	(21.5)	52
0.82	(21.0)	55
0.80	(20.5)	58
0.78	(20.0)	61
0.76	(19.5)	64
0.74	(19.0)	67
0.72	(18.5)	70
0.70	(18.0)	73
0.68	(17.5)	76
0.66	(17.0)	79
0.64	(16.5)	82
0.62	(15.5)	85
0.60	(15.0)	88
0.58	(14.5)	91
0.56	(14.0)	94
0.54	(13.5)	97
0.52	(13.0)	100
0.50	(12.5)	103
0.48	(12.0)	106
0.46	(11.5)	109
0.44	(11.0)	112
0.42	(10.5)	115
0.40	(10.0)	118
0.38	(9.5)	121

- 1 New Tread diameter is 29.07 in. (738.5 mm)
- 2 For measuring instructions, reference General Information topic *Idler Wear – Center Tread Idlers* on, page 51.
- 3 Wear Chart: 4103

Idlers <sup>(1)</sup> <sup>(2)</sup> <sup>(3)</sup>  
Conventional

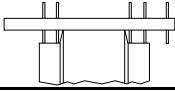

Depth Gauge

Inches	(mm)	% Worn
0.78	(20.0)	0
0.80	(20.5)	6
0.82	(21.0)	12
0.84	(21.5)	18
0.86	(22.0)	24
0.88	(22.5)	30
0.90	(23.0)	36
0.92	(23.5)	42
0.94	(24.0)	48
0.96	(24.5)	54
0.98	(25.0)	60
1.00	(25.5)	66
1.02	(26.0)	72
1.04	(26.5)	76
1.06	(27.0)	78
1.08	(27.5)	80
1.10	(28.0)	82
1.12	(28.5)	84
1.14	(29.0)	86
1.16	(29.5)	88
1.18	(30.0)	90
1.20	(30.5)	92
1.22	(31.0)	94
1.24	(31.5)	96
1.26	(32.0)	98
1.28	(32.5)	100
1.30	(33.0)	102
1.32	(33.5)	104
1.34	(34.0)	106
1.36	(34.5)	108
1.38	(35.0)	110
1.40	(35.5)	112
1.42	(36.0)	114
1.44	(36.5)	116
1.46	(37.0)	118
1.48	(37.5)	120

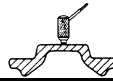

Ultrasonic

Center Flange Wear

Inches	(mm)	Inches	(mm)
0.49	(12.4)	0.00	(0.0)
0.47	(11.9)	0.02	(0.5)
0.45	(11.4)	0.04	(1.0)
0.43	(10.9)	0.06	(1.5)
0.41	(10.4)	0.08	(2.0)
0.39	(9.9)	0.10	(2.5)
0.37	(9.4)	0.12	(3.0)
0.35	(8.9)	0.14	(3.5)
0.33	(8.4)	0.16	(4.0)
0.31	(7.9)	0.18	(4.5)
0.29	(7.4)	0.20	(5.0)
0.27	(6.9)	0.22	(5.5)
0.25	(6.3)	0.24	(6.0)
0.23	(5.8)	0.26	(6.5)
0.21	(5.3)	0.28	(7.0)
0.19	(4.8)	0.30	(7.5)
0.17	(4.3)	0.32	(8.0)
0.15	(3.8)	0.34	(8.5)
0.13	(3.3)	0.36	(9.0)
0.11	(2.8)	0.38	(9.5)
0.09	(2.3)	0.40	(10.0)
0.07	(1.8)	0.42	(10.5)
0.05	(1.3)	0.44	(11.0)
0.03	(0.8)	0.46	(11.5)
0.01	(0.3)	0.48	(12.0)

**NOTE**

Ultrasonic measurement is to determine flange wear only.

- 1 Flange width is 3.74 in. (95 mm)
- 2 New tread diameter is 26.61 in. (676 mm)
- 3 Wear Chart: 4402

**963 - 8.00 in. (203.2 mm)**

**Carrier Rollers<sup>(1)</sup>  
SystemOne Track**

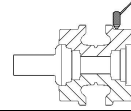
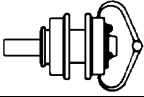

Caliper			Ultrasonic		
All			One-piece rim		
Inches	(mm)	% Worn	Inches	(mm)	
7.84	(199.0)	0	2.31	(58.7)	
7.76	(197.0)	8	2.27	(57.7)	
7.68	(195.0)	16	2.23	(56.6)	
7.60	(193.0)	24	2.19	(55.6)	
7.52	(191.0)	32	2.15	(54.6)	
7.44	(189.0)	40	2.11	(53.6)	
7.36	(187.0)	44	2.07	(52.6)	
7.28	(185.0)	48	2.03	(51.6)	
7.20	(183.0)	52	1.99	(50.5)	
7.12	(181.0)	56	1.95	(49.5)	
7.04	(179.0)	60	1.91	(48.5)	
6.96	(177.0)	64	1.87	(47.5)	
6.88	(175.0)	68	1.83	(46.5)	
6.80	(172.5)	72	1.79	(45.5)	
6.72	(170.5)	76	1.75	(44.5)	
6.64	(168.5)	80	1.71	(43.4)	
6.56	(166.5)	84	1.67	(42.4)	
6.48	(164.5)	88	1.63	(41.4)	
6.40	(162.5)	92	1.59	(40.4)	
6.32	(160.5)	96	1.55	(39.4)	
6.24	(158.5)	100	1.51	(38.4)	
6.16	(156.5)	104	1.47	(37.3)	
6.08	(154.5)	108	1.43	(36.3)	
6.00	(152.5)	112	1.39	(35.3)	
5.92	(150.5)	116	1.35	(34.3)	
5.84	(148.5)	120	1.31	(33.3)	

1 Wear Chart: 4701

Carrier Rollers <sup>(1)</sup>  
Conventional

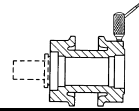
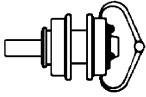

Caliper			Ultrasonic		
Inches	(mm)	% Worn	Inches	(mm)	
7.38	(187.5)	0	1.86	(47.2)	
7.30	(185.5)	8	1.82	(46.2)	
7.22	(183.5)	16	1.78	(45.2)	
7.14	(181.5)	24	1.74	(44.2)	
7.06	(179.5)	32	1.70	(43.2)	
6.98	(177.5)	40	1.66	(42.2)	
6.90	(175.5)	48	1.62	(41.1)	
6.82	(173.0)	56	1.58	(40.1)	
6.74	(171.0)	64	1.54	(39.1)	
6.66	(169.0)	68	1.50	(38.1)	
6.58	(167.0)	72	1.46	(37.1)	
6.50	(165.0)	76	1.42	(36.1)	
6.42	(163.0)	80	1.38	(35.1)	
6.34	(161.0)	84	1.34	(34.0)	
6.26	(159.0)	88	1.30	(33.0)	
6.18	(157.0)	92	1.26	(32.0)	
6.10	(155.0)	96	1.22	(31.0)	
6.02	(153.0)	100	1.18	(30.0)	
5.94	(151.0)	104	1.14	(29.0)	
5.86	(149.0)	108	1.10	(27.9)	
5.78	(147.0)	112	1.06	(26.9)	
5.70	(145.0)	116	1.02	(25.9)	
5.62	142.5	120	0.98	(24.9)	

**963 - 8.00 in. (203.2 mm)**

**Track Rollers <sup>(1) (2)</sup>  
SystemOne™**

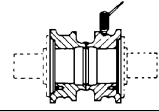
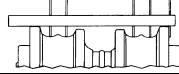
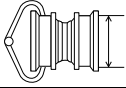

Caliper		% Worn	Depth Gauge		Ultrasonic	
Inches	(mm)		Inches	(mm)	Inches	(mm)
8.26	(210.0)	0	0.82	(21.0)	1.88	(47.8)
8.18	(208.0)	6	0.86	(22.0)	1.84	(46.7)
8.10	(205.5)	12	0.90	(23.0)	1.80	(45.7)
8.02	(203.5)	18	0.94	(24.0)	1.76	(44.7)
7.94	(201.5)	24	0.98	(25.0)	1.72	(43.7)
7.86	(199.5)	30	1.02	(26.0)	1.68	(42.7)
7.78	(197.5)	36	1.06	(27.0)	1.64	(41.7)
7.70	(195.5)	42	1.10	(28.0)	1.60	(40.6)
7.62	(193.5)	48	1.14	(29.0)	1.56	(39.6)
7.54	(191.5)	54	1.18	(30.0)	1.52	(38.6)
7.46	(189.5)	60	1.22	(31.0)	1.48	(37.6)
7.38	(187.5)	64	1.26	(32.0)	1.44	(36.6)
7.30	(185.5)	68	1.30	(33.0)	1.40	(35.6)
7.22	(183.5)	72	1.34	(34.0)	1.36	(34.5)
7.14	(181.5)	76	1.38	(35.0)	1.32	(33.5)
7.06	(179.5)	80	1.42	(36.0)	1.28	(32.5)
6.98	(177.5)	84	1.46	(37.0)	1.24	(31.5)
6.90	(175.5)	88	1.50	(38.0)	1.20	(30.5)
6.82	(173.0)	92	1.54	(39.0)	1.16	(29.5)
6.74	(171.0)	96	1.58	(40.0)	1.12	(28.4)
6.66	(169.0)	100	1.62	(41.0)	1.08	(27.4)
6.58	(167.0)	104	1.66	(42.0)	1.04	(26.4)
6.50	(165.0)	108	1.70	(43.0)	1.00	(25.4)
6.42	(163.0)	112	1.74	(44.0)	0.96	(24.4)
6.34	(161.0)	116	1.78	(45.0)	0.92	(23.4)
6.26	(159.0)	120	1.82	(46.0)	0.88	(22.4)

1 Flange Diameter is 9.92 in. (252 mm)

2 Wear Chart: 5306



Track Rollers <sup>(1) (2)</sup>  
Conventional

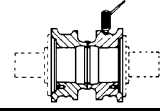
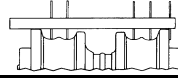

Caliper		% Worn	Depth Gauge		Ultrasonic	
Inches	(mm)		Inches	(mm)	Inches	(mm)
8.26	(210.0)	0	0.59	(15.0)	1.88	(47.8)
8.18	(208.0)	6	0.63	(16.0)	1.84	(46.7)
8.10	(205.5)	12	0.67	(17.0)	1.80	(45.7)
8.02	(203.5)	18	0.71	(18.0)	1.76	(44.7)
7.94	(201.5)	24	0.75	(19.0)	1.72	(43.7)
7.86	(199.5)	30	0.79	(20.0)	1.68	(42.7)
7.78	(197.5)	36	0.83	(21.0)	1.64	(41.7)
7.70	(195.5)	42	0.87	(22.0)	1.60	(40.6)
7.62	(193.5)	48	0.91	(23.0)	1.56	(39.6)
7.54	(191.5)	54	0.95	(24.0)	1.52	(38.6)
7.46	(189.5)	60	0.99	(25.0)	1.48	(37.6)
7.38	(187.5)	64	1.03	(26.0)	1.44	(36.6)
7.30	(185.5)	68	1.07	(27.0)	1.40	(35.6)
7.22	(183.5)	72	1.11	(28.0)	1.36	(34.5)
7.14	(181.5)	76	1.15	(29.0)	1.32	(33.5)
7.06	(179.5)	80	1.19	(30.0)	1.28	(32.5)
6.98	(177.5)	84	1.23	(31.0)	1.24	(31.5)
6.90	(175.5)	88	1.27	(32.5)	1.20	(30.5)
6.82	(173.0)	92	1.31	(33.5)	1.16	(29.5)
6.74	(171.0)	96	1.35	(34.5)	1.12	(28.4)
6.66	(169.0)	100	1.39	(35.5)	1.08	(27.4)
6.58	(167.0)	104	1.43	(36.5)	1.04	(26.4)
6.50	(165.0)	108	1.47	(37.5)	1.00	(25.4)
6.42	(163.0)	112	1.51	(38.5)	0.96	(24.4)
6.34	(161.0)	116	1.55	(39.5)	0.92	(23.4)
6.26	(159.0)	120	1.59	(40.5)	0.88	(22.4)

1 Flange diameter is 9.45 in. (240 mm)  
2 Wear Chart: 5312

**963 - 8.00 in. (203.2 mm)**

**Track Rollers <sup>(1) (2)</sup>  
Tall Flange Double Range Rollers  
Standardized Press on Collar Track Rollers**

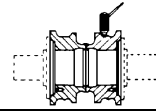
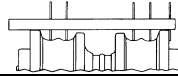
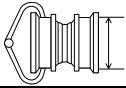

Caliper			Depth Gauge		Ultrasonic	
Inches	(mm)	% Worn	Inches	(mm)	Inches	(mm)
8.26	(210.0)	0	0.77	(19.5)	1.88	(47.8)
8.20	(208.5)	5	0.80	(20.5)	1.85	(47.0)
8.14	(207.0)	10	0.83	(21.0)	1.82	(46.2)
8.08	(205.0)	15	0.86	(22.0)	1.79	(45.5)
8.02	(203.5)	20	0.89	(22.5)	1.76	(44.7)
7.96	(202.0)	25	0.92	(23.5)	1.73	(43.9)
7.90	(200.5)	30	0.95	(24.0)	1.70	(43.2)
7.84	(199.0)	35	0.98	(25.0)	1.67	(42.4)
7.78	(197.5)	40	1.01	(25.5)	1.64	(41.7)
7.72	(196.0)	45	1.04	(26.5)	1.61	(40.9)
7.66	(194.5)	50	1.07	(27.0)	1.58	(40.1)
7.60	(193.0)	55	1.10	(28.0)	1.55	(39.4)
7.54	(191.5)	60	1.13	(28.5)	1.52	(38.6)
7.48	(190.0)	65	1.16	(29.5)	1.49	(37.8)
7.42	(188.5)	70	1.19	(30.0)	1.46	(37.1)
7.36	(187.0)	75	1.22	(31.0)	1.43	(36.3)
7.30	(185.5)	80	1.25	(32.0)	1.40	(35.6)
7.24	(184.0)	85	1.28	(32.5)	1.37	(34.8)
7.18	(182.5)	90	1.31	(33.5)	1.34	(34.0)
7.12	(181.0)	95	1.34	(34.0)	1.31	(33.3)
7.06	(179.5)	100	1.37	(35.0)	1.28	(32.5)
7.00	(178.0)	104	1.40	(35.5)	1.25	(31.8)
6.94	(176.5)	108	1.43	(36.5)	1.22	(31.0)
6.88	(175.0)	112	1.46	(37.0)	1.19	(30.2)
6.82	(173.0)	116	1.49	(38.0)	1.16	(29.5)
6.76	(171.5)	120	1.52	(38.5)	1.13	(28.7)

1 Flange diameter is 9.82 in. (249.5 mm)

2 Wear Chart: 6201



**973 - 8.50 in. (215.9 mm)**

**Track Links <sup>(1)</sup>  
Enhanced SALT Track  
233-0379 & 80, 233-0385 & 86,  
255-4789 & 90, 289-3083 & 84**

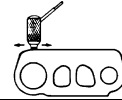
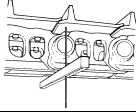

Depth Gauge			Ultrasonic	
Inches	(mm)	% Worn	Inches	(mm)
5.31	(135.0)	0	1.62	(41.1)
5.29	(134.5)	5	1.60	(40.6)
5.27	(134.0)	10	1.58	(40.1)
5.25	(133.5)	15	1.56	(39.6)
5.23	(133.0)	20	1.54	(39.1)
5.21	(132.5)	25	1.52	(38.6)
5.19	(132.0)	30	1.50	(38.1)
5.17	(131.5)	35	1.48	(37.6)
5.15	(131.0)	40	1.46	(37.1)
5.13	(130.5)	45	1.44	(36.6)
5.11	(130.0)	50	1.42	(36.1)
5.09	(129.5)	55	1.40	(35.6)
5.07	(129.0)	60	1.38	(35.1)
5.05	(128.5)	64	1.36	(34.5)
5.03	(128.0)	67	1.34	(34.0)
5.01	(127.5)	70	1.32	(33.5)
4.99	(126.5)	73	1.30	(33.0)
4.97	(126.0)	76	1.28	(32.5)
4.95	(125.5)	79	1.26	(32.0)
4.93	(125.0)	82	1.24	(31.5)
4.91	(124.5)	85	1.22	(31.0)
4.89	(124.0)	88	1.20	(30.5)
4.87	(123.5)	91	1.18	(30.0)
4.85	(123.0)	94	1.16	(29.5)
4.83	(122.5)	97	1.14	(29.0)
4.81	(122.0)	100	1.12	(28.4)
4.79	(121.5)	103	1.10	(27.9)
4.77	(121.0)	106	1.08	(27.4)
4.75	(120.5)	109	1.06	(26.9)
4.73	(120.0)	112	1.04	(26.4)
4.71	(119.5)	115	1.02	(25.9)
4.69	(119.0)	118	1.00	(25.4)
4.67	(118.5)	121	0.98	(24.9)

**Track Links <sup>(1)</sup>  
Rotating Bushing Track  
61-9239 & 40  
165-1758 & 59**

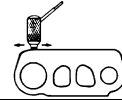
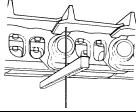

Depth Gauge			Ultrasonic	
Inches	(mm)	% Worn	Inches	(mm)
5.50	(139.5)	0	1.66	(42.2)
5.48	(139.0)	4	1.64	(41.7)
5.46	(138.5)	8	1.62	(41.1)
5.44	(138.0)	12	1.60	(40.6)
5.42	(137.5)	16	1.58	(40.1)
5.40	(137.0)	20	1.56	(39.6)
5.38	(136.5)	24	1.54	(39.1)
5.36	(136.0)	28	1.52	(38.6)
5.34	(135.5)	32	1.50	(38.1)
5.32	(135.0)	36	1.48	(37.6)
5.30	(134.5)	40	1.46	(37.1)
5.28	(134.0)	44	1.44	(36.6)
5.26	(133.5)	48	1.42	(36.1)
5.24	(133.0)	52	1.40	(35.6)
5.22	(132.5)	56	1.38	(35.1)
5.20	(132.0)	60	1.36	(34.5)
5.18	(131.5)	64	1.34	(34.0)
5.16	(131.0)	68	1.32	(33.5)
5.14	(130.5)	72	1.30	(33.0)
5.12	(130.0)	76	1.28	(32.5)
5.10	(129.5)	80	1.26	(32.0)
5.08	(129.0)	84	1.24	(31.5)
5.06	(128.5)	88	1.22	(31.0)
5.04	(128.0)	92	1.20	(30.5)
5.02	(127.5)	96	1.18	(30.0)
5.00	(127.0)	100	1.16	(29.5)
4.98	(126.5)	104	1.14	(29.0)
4.96	(126.0)	108	1.12	(28.4)
4.94	(125.5)	112	1.10	(27.9)
4.92	(125.0)	116	1.08	(27.4)
4.90	(124.5)	120	1.06	(26.9)

**973 - 8.50 in. (215.9 mm)**

**Track Links <sup>(1)</sup>  
Sealed & Lubricated Track  
Sealed Track  
6Y-2593 & 94  
7T-4657 & 58**

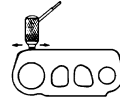
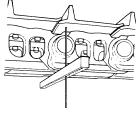

Depth Gauge			Ultrasonic	
Inches	(mm)	% Worn	Inches	(mm)
5.23	(133.0)	0	1.64	(41.7)
5.21	(132.5)	4	1.62	(41.1)
5.19	(132.0)	8	1.60	(40.6)
5.17	(131.5)	12	1.58	(40.1)
5.15	(131.0)	16	1.56	(39.6)
5.13	(130.5)	20	1.54	(39.1)
5.11	(130.0)	24	1.52	(38.6)
5.09	(129.5)	28	1.50	(38.1)
5.07	(129.0)	32	1.48	(37.6)
5.05	(128.5)	36	1.46	(37.1)
5.03	(128.0)	40	1.44	(36.6)
5.01	(127.5)	44	1.42	(36.1)
4.99	(126.5)	48	1.40	(35.6)
4.97	(126.0)	52	1.38	(35.1)
4.95	(125.5)	56	1.36	(34.5)
4.93	(125.0)	60	1.34	(34.0)
4.91	(124.5)	64	1.32	(33.5)
4.89	(124.0)	68	1.30	(33.0)
4.87	(123.5)	72	1.28	(32.5)
4.85	(123.0)	76	1.26	(32.0)
4.83	(122.5)	80	1.24	(31.5)
4.81	(122.0)	84	1.22	(31.0)
4.79	(121.5)	88	1.20	(30.5)
4.77	(121.0)	92	1.18	(30.0)
4.75	(120.5)	96	1.16	(29.5)
4.73	(120.0)	100	1.14	(29.0)
4.71	(119.5)	103	1.12	(28.4)
4.69	(119.0)	106	1.10	(27.9)
4.67	(118.5)	109	1.08	(27.4)
4.65	(118.0)	112	1.06	(26.9)
4.63	(117.5)	115	1.04	(26.4)
4.61	(117.0)	118	1.02	(25.9)
4.59	(116.5)	121	1.00	(25.4)

**Bushings <sup>(1)</sup>  
External Wear  
Sealed & Lubricated Track  
Enhanced SALT Track  
Use with 233-0379 & 80, 233-4789 & 90, or 289-3083 & 84 Links**

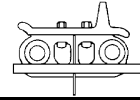
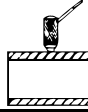

Caliper		Allowable Wear		Ultrasonic		Depth Gauge	
Inches	(mm)	Lesser % Worn	Greater % Worn	Inches	(mm)	Inches	(mm)
3.11	(79.0)	0	0	0.60	(15.2)	3.78	(96.0)
3.09	(78.5)	12	10	0.58	(14.7)	3.76	(95.5)
3.07	(78.0)	22	20	0.56	(14.2)	3.74	(95.0)
3.05	(77.5)	28	30	0.54	(13.7)	3.72	(94.5)
3.03	(77.0)	34	36	0.52	(13.2)	3.70	(94.0)
3.01	(76.5)	40	40	0.50	(12.7)	3.68	(93.5)
2.99	(75.9)	46	44	0.48	(12.2)	3.66	(93.0)
2.97	(75.4)	52	48	0.46	(11.7)	3.64	(92.5)
2.95	(74.9)	58	52	0.44	(11.2)	3.62	(91.9)
2.93	(74.4)	64	56	0.42	(10.7)	3.60	(91.4)
2.91	(73.9)	70	60	0.40	(10.2)	3.58	(90.9)
2.89	(73.4)	76	64	0.38	(9.7)	3.56	(90.4)
2.87	(72.9)	82	68	0.36	(9.1)	3.54	(89.9)
2.85	(72.4)	88	72	0.34	(8.6)	3.52	(89.4)
2.83	(71.9)	94	76	0.32	(8.1)	3.50	(88.9)
2.81	(71.4)	100	80	0.30	(7.6)	3.48	(88.4)
2.79	(70.9)	106	84	0.28	(7.1)	3.46	(87.9)
2.77	(70.4)	112	88	0.26	(6.6)	3.44	(87.4)
2.75	(69.9)	118	92	0.24	(6.1)	3.42	(86.9)
2.73	(69.3)	124	96	0.22	(5.6)	3.40	(86.4)
2.71	(68.8)		100	0.20	(5.1)	3.38	(85.9)
2.69	(68.3)		104	0.18	(4.6)	3.36	(85.3)
2.67	(67.8)		108	0.16	(4.1)	3.34	(84.8)
2.65	(67.3)		112	0.14	(3.6)	3.32	(84.3)
2.63	(66.8)		116	0.12	(3.0)	3.30	(83.8)
2.61	(66.3)		120	0.10	(2.5)	3.28	(83.3)

**973 - 8.50 in. (215.9 mm)**

**Bushings <sup>(1)</sup>  
External Wear  
Rotating Bushing Track  
Use with 6I Links**

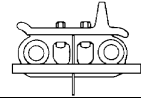
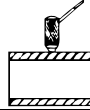

Caliper			Ultrasonic		Depth Gauge	
Inches	(mm)	% Worn	Inches	(mm)	Inches	(mm)
3.11	(79.0)	0	0.61	(15.5)	3.86	(98.0)
3.07	(78.0)	8	0.59	(15.0)	3.84	(97.5)
3.03	(77.0)	16	0.57	(14.5)	3.82	(97.0)
2.99	(75.9)	24	0.55	(14.0)	3.80	(96.5)
2.95	(74.9)	32	0.53	(13.5)	3.78	(96.0)
2.91	(73.9)	40	0.51	(13.0)	3.76	(95.5)
2.87	(72.9)	44	0.49	(12.4)	3.74	(95.0)
2.83	(71.9)	48	0.47	(11.9)	3.72	(94.5)
2.79	(70.9)	52	0.45	(11.4)	3.70	(94.0)
2.75	(69.9)	56	0.43	(10.9)	3.68	(93.5)
2.71	(68.8)	60	0.41	(10.4)	3.66	(93.0)
2.67	(67.8)	64	0.39	(9.9)	3.64	(92.5)
2.63	(66.8)	68	0.37	(9.4)	3.62	(91.9)
2.59	(65.8)	72	0.35	(8.9)	3.60	(91.4)
2.55	(64.8)	76	0.33	(8.4)	3.58	(90.9)
2.51	(63.8)	80	0.31	(7.9)	3.56	(90.4)
2.47	(62.7)	84	0.29	(7.4)	3.54	(89.9)
2.43	(61.7)	88	0.27	(6.9)	3.52	(89.4)
2.39	(60.7)	92	0.25	(6.3)	3.50	(88.9)
2.35	(59.7)	96	0.23	(5.8)	3.48	(88.4)
2.31	(58.7)	100	0.21	(5.3)	3.46	(87.9)
2.27	(57.7)	104	0.19	(4.8)	3.44	(87.4)
2.23	(56.6)	108	0.17	(4.3)	3.42	(86.9)
2.19	(55.6)	112	0.15	(3.8)	3.40	(86.4)
2.15	(54.6)	116	0.13	(3.3)	3.38	(85.9)
2.11	(53.6)	120	0.11	(2.8)	3.36	(85.3)

**Note: Do Not Use Depth Gauge Until Bushings Have Been "Turned."**

1 Wear Chart: 727/728



**Bushings <sup>(1)</sup>  
External Wear  
Sealed & Lubricated Track  
Use with 6Y & 7T Links**

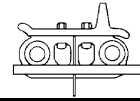
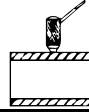

Caliper		Allowable Wear		Ultrasonic		Depth Gauge	
Inches	(mm)	Lesser % Worn	Greater % Worn	Inches	(mm)	Inches	(mm)
3.04	(77.2)	0	0	0.56	(14.2)	3.69	(93.7)
3.02	(76.7)	12	10	0.54	(13.7)	3.67	(93.2)
3.00	(76.2)	24	20	0.52	(13.2)	3.65	(92.7)
2.98	(75.7)	36	30	0.50	(12.7)	3.63	(92.2)
2.96	(75.2)	48	40	0.48	(12.2)	3.61	(91.7)
2.94	(74.7)	58	50	0.46	(11.7)	3.59	(91.2)
2.92	(74.2)	64	56	0.44	(11.2)	3.57	(90.7)
2.90	(73.7)	70	60	0.42	(10.7)	3.55	(90.2)
2.88	(73.2)	76	64	0.40	(10.2)	3.53	(89.7)
2.86	(72.6)	82	68	0.38	(9.7)	3.51	(89.2)
2.84	(72.1)	88	72	0.36	(9.1)	3.49	(88.6)
2.82	(71.6)	94	76	0.34	(8.6)	3.47	(88.1)
2.80	(71.1)	100	80	0.32	(8.1)	3.45	(87.6)
2.78	(70.6)	106	84	0.30	(7.6)	3.43	(87.1)
2.76	(70.1)	112	88	0.28	(7.1)	3.41	(86.6)
2.74	(69.6)	118	92	0.26	(6.6)	3.39	(86.1)
2.72	(69.1)	124	96	0.24	(6.1)	3.37	(85.6)
2.70	(68.6)		100	0.22	(5.6)	3.35	(85.1)
2.68	(68.1)		104	0.20	(5.1)	3.33	(84.6)
2.66	(67.6)		108	0.18	(4.6)	3.31	(84.1)
2.64	(67.1)		112	0.16	(4.1)	3.29	(83.6)
2.62	(66.5)		116	0.14	(3.6)	3.27	(83.1)
2.60	(66.0)		120	0.12	(3.0)	3.25	(82.6)

**973 - 8.50 in. (215.9 mm)**

**Pins and Bushings <sup>(1)</sup>  
Internal Wear  
Sealed Track**

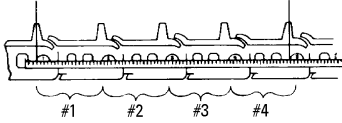

<b>Inches</b>	<b>(mm)</b>	<b>% Worn</b>
34.05	(865.0)	0
34.10	(866.0)	10
34.15	(867.5)	20
34.20	(868.5)	30
34.25	(870.0)	40
34.30	(871.0)	50
34.35	(872.5)	60
34.40	(874.0)	70
34.45	(875.0)	80
34.50	(876.5)	90
34.55	(877.5)	100
34.60	(879.0)	105
34.65	(880.0)	110
34.70	(881.5)	115
34.75	(882.5)	120

1 Wear Chart: 420

**Bushings <sup>(1)</sup>  
External Wear  
Hybrid Sealed Track**

Use with 233-0379 & 80, 233-4789 & 90, or 289-3083 & 84 Links



Caliper		Allowable Wear		Ultrasonic	
Inches	(mm)	Lesser % Worn	Greater % Worn	Inches	(mm)
3.04	(77.2)	0	0	0.56	(14.2)
3.03	(77.0)	6	5	0.55	(14.0)
3.02	(76.7)	12	10	0.54	(13.7)
3.01	(76.5)	18	15	0.53	(13.5)
3.00	(76.2)	24	20	0.52	(13.2)
2.99	(75.9)	30	25	0.51	(13.0)
2.98	(75.7)	36	30	0.50	(12.7)
2.97	(75.4)	42	35	0.49	(12.4)
2.96	(75.2)	48	40	0.48	(12.2)
2.95	(74.9)	54	45	0.47	(11.9)
2.94	(74.7)	60	50	0.46	(11.7)
2.93	(74.4)	64	55	0.45	(11.4)
2.92	(74.2)	67	60	0.44	(11.2)
2.91	(73.9)	70	65	0.43	(10.9)
2.90	(73.7)	73	68	0.42	(10.7)
2.89	(73.4)	76	70	0.41	(10.4)
2.88	(73.2)	79	72	0.40	(10.2)
2.87	(72.9)	82	74	0.39	(9.9)
2.86	(72.6)	85	76	0.38	(9.7)
2.85	(72.4)	88	78	0.37	(9.4)
2.84	(72.1)	91	80	0.36	(9.1)
2.83	(71.9)	94	82	0.35	(8.9)
2.82	(71.6)	97	84	0.34	(8.6)
2.81	(71.4)	100	86	0.33	(8.4)
2.80	(71.1)	103	88	0.32	(8.1)
2.79	(70.9)	106	90	0.31	(7.9)
2.78	(70.6)	109	92	0.30	(7.6)
2.77	(70.4)	112	94	0.29	(7.4)
2.76	(70.1)	115	96	0.28	(7.1)
2.75	(69.9)	118	98	0.27	(6.9)
2.74	(69.6)	121	100	0.26	(6.6)
2.73	(69.3)		102	0.25	(6.3)
2.72	(69.1)		104	0.24	(6.1)
2.71	(68.8)		106	0.23	(5.8)
2.70	(68.6)		108	0.22	(5.6)
2.69	(68.3)		110	0.21	(5.3)
2.68	(68.1)		112	0.20	(5.1)
2.67	(67.8)		114	0.19	(4.8)
2.66	(67.6)		116	0.18	(4.6)
2.65	(67.3)		118	0.17	(4.3)
2.64	(67.1)		120	0.16	(4.1)

**973 - 8.50 in. (215.9 mm)**

**Bushings <sup>(1)</sup>  
External Wear  
Sealed Track  
Use with 6Y & 7T Links**

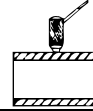

<b>Allowable Wear</b>					
<b>Caliper</b>		<b>Lesser</b>	<b>Greater</b>	<b>Ultrasonic</b>	
<b>Inches</b>	<b>(mm)</b>	<b>% Worn</b>	<b>% Worn</b>	<b>Inches</b>	<b>(mm)</b>
2.83	(71.9)	0	0	0.46	(11.7)
2.82	(71.6)	9	7	0.45	(11.4)
2.81	(71.4)	18	14	0.44	(11.2)
2.80	(71.1)	27	21	0.43	(10.9)
2.79	(70.9)	36	28	0.42	(10.7)
2.78	(70.6)	45	35	0.41	(10.4)
2.77	(70.4)	54	42	0.40	(10.2)
2.76	(70.1)	63	49	0.39	(9.9)
2.75	(69.9)	72	56	0.38	(9.7)
2.74	(69.6)	81	63	0.37	(9.4)
2.73	(69.3)	88	70	0.36	(9.1)
2.72	(69.1)	92	73	0.35	(8.9)
2.71	(68.8)	96	76	0.34	(8.6)
2.70	(68.6)	100	79	0.33	(8.4)
2.69	(68.3)	104	82	0.32	(8.1)
2.68	(68.1)	108	85	0.31	(7.9)
2.67	(67.8)	112	88	0.30	(7.6)
2.66	(67.6)	116	91	0.29	(7.4)
2.65	(67.3)	120	94	0.28	(7.1)
2.64	(67.1)		97	0.27	(6.9)
2.63	(66.8)		100	0.26	(6.6)
2.62	(66.5)		103	0.25	(6.4)
2.61	(66.3)		106	0.24	(6.1)
2.60	(66.0)		109	0.23	(5.8)
2.59	(65.8)		112	0.22	(5.6)
2.58	(65.5)		115	0.21	(5.3)
2.57	(65.3)		118	0.20	(5.1)
2.56	(65.0)		121	0.19	(4.8)

**Track Shoes <sup>(1)</sup>  
Extreme Service**

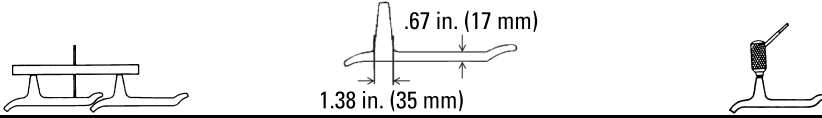

Depth Gauge		High Impact	Low/Moderate	Ultrasonic	
Inches	(mm)	% Worn	Impact % Worn	Inches	(mm)
3.20	(81.5)	0	0	3.90	(99.1)
3.10	(78.5)	6	5	3.80	(96.5)
3.00	(76.0)	12	10	3.70	(94.0)
2.90	(73.5)	18	15	3.60	(91.4)
2.80	(71.0)	24	20	3.50	(88.9)
2.70	(68.5)	30	25	3.40	(86.4)
2.60	(66.0)	36	30	3.30	(83.8)
2.50	(63.5)	42	35	3.20	(81.3)
2.40	(61.0)	48	40	3.10	(78.7)
2.30	(58.5)	54	45	3.00	(76.2)
2.20	(56.0)	60	50	2.90	(73.7)
2.10	(53.5)	66	55	2.80	(71.1)
2.00	(51.0)	72	60	2.70	(68.6)
1.90	(48.5)	78	64	2.60	(66.0)
1.80	(45.5)	84	68	2.50	(63.5)
1.70	(43.0)	90	72	2.40	(61.0)
1.60	(40.5)	95	76	2.30	(58.4)
1.50	(38.0)	100	80	2.20	(55.9)
1.40	(35.5)	105	84	2.10	(53.3)
1.30	(33.0)	110	88	2.00	(50.8)
1.20	(30.5)	115	92	1.90	(48.3)
1.10	(28.0)	120	96	1.80	(45.7)
1.00	(25.5)		100	1.70	(43.2)
0.90	(23.0)		104	1.60	(40.6)
0.80	(20.5)		108	1.50	(38.1)
0.70	(18.0)		112	1.40	(35.6)
0.60	(15.0)		116	1.30	(33.0)
0.50	(12.5)		120	1.20	(30.5)

**973 - 8.50 in. (215.9 mm)**

**Track Shoes <sup>(1)</sup>  
Moderate Service**

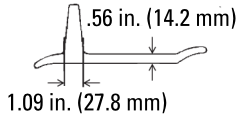
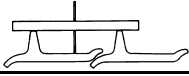

Depth Gauge		High Impact	Low/Moderate	Ultrasonic	
Inches	(mm)	% Worn	Impact % Worn	Inches	(mm)
2.90	(73.5)	0	0	3.45	(87.6)
2.80	(71.0)	8	6	3.35	(85.1)
2.70	(68.5)	16	12	3.25	(82.6)
2.60	(66.0)	23	18	3.15	(80.0)
2.50	(63.5)	30	24	3.05	(77.5)
2.40	(61.0)	37	30	2.95	(74.9)
2.30	(58.5)	44	35	2.85	(72.4)
2.20	(56.0)	51	40	2.75	(69.9)
2.10	(53.5)	58	45	2.65	(67.3)
2.00	(51.0)	65	50	2.55	(64.8)
1.90	(48.5)	72	55	2.45	(62.2)
1.80	(45.5)	79	60	2.35	(59.7)
1.70	(43.0)	86	65	2.25	(57.2)
1.60	(40.5)	93	70	2.15	(54.6)
1.50	(38.0)	100	75	2.05	(52.1)
1.40	(35.5)	107	80	1.95	(49.5)
1.30	(33.0)	114	85	1.85	(47.0)
1.20	(30.5)	121	90	1.75	(44.5)
1.10	(28.0)		95	1.65	(41.9)
1.00	(25.5)		100	1.55	(39.4)
0.90	(23.0)		105	1.45	(36.8)
0.80	(20.5)		110	1.35	(34.3)
0.70	(18.0)		115	1.25	(31.8)
0.60	(15.0)		120	1.15	(29.2)

**Track Shoes <sup>(1)</sup>  
Double Grouser**

.61 in. (15.5 mm)

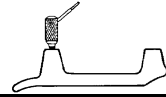
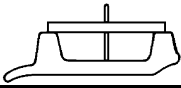

Depth Gauge		High Impact	Low/Moderate	Ultrasonic	
Inches	(mm)	% Worn	Impact % Worn	Inches	(mm)
1.95	(49.5)	0	0	2.55	(64.8)
1.90	(48.5)	5	4	2.50	(63.5)
1.85	(47.0)	10	8	2.45	(62.2)
1.80	(45.5)	15	12	2.40	(61.0)
1.75	(44.5)	20	16	2.35	(59.7)
1.70	(43.0)	24	20	2.30	(58.4)
1.65	(42.0)	28	24	2.25	(57.2)
1.60	(40.5)	32	28	2.20	(55.9)
1.55	(39.5)	36	32	2.15	(54.6)
1.50	(38.0)	40	36	2.10	(53.3)
1.45	(37.0)	44	40	2.05	(52.1)
1.40	(35.5)	48	44	2.00	(50.8)
1.35	(34.5)	52	48	1.95	(49.5)
1.30	(33.0)	56	52	1.90	(48.3)
1.25	(32.0)	60	55	1.85	(47.0)
1.20	(30.5)	64	58	1.80	(45.7)
1.15	(29.0)	68	61	1.75	(44.5)
1.10	(28.0)	72	64	1.70	(43.2)
1.05	(26.5)	76	67	1.65	(41.9)
1.00	(25.5)	80	70	1.60	(40.6)
0.95	(24.0)	84	73	1.55	(39.4)
0.90	(23.0)	88	76	1.50	(38.1)
0.85	(21.5)	92	79	1.45	(36.8)
0.80	(20.5)	96	82	1.40	(35.6)
0.75	(19.0)	100	85	1.35	(34.3)
0.70	(18.0)	104	88	1.30	(33.0)
0.65	(16.5)	108	91	1.25	(31.8)
0.60	(15.0)	112	94	1.20	(30.5)
0.55	(14.0)	116	97	1.15	(29.2)
0.50	(12.5)	120	100	1.10	(27.9)
0.45	(11.5)		103	1.05	(26.7)
0.40	(10.0)		106	1.00	(25.4)
0.35	(9.0)		109	0.95	(24.1)
0.30	(7.5)		112	0.90	(22.9)
0.25	(6.5)		115	0.85	(21.6)
0.20	(5.0)		118	0.80	(20.3)
0.15	(4.0)		121	0.75	(19.1)

**973 - 8.50 in. (215.9 mm)**

**Track Shoes <sup>(1)</sup>  
Triple Grouser**

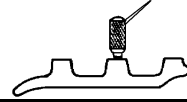
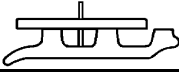
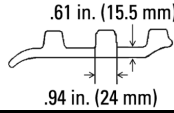

Depth Gauge			Ultrasonic		
Inches	(mm)	% Worn	Inches	(mm)	
1.35	(34.5)	0	1.95	(49.5)	
1.30	(33.0)	6	1.90	(48.2)	
1.25	(32.0)	12	1.85	(47.0)	
1.20	(30.5)	18	1.80	(45.7)	
1.15	(29.0)	24	1.75	(44.4)	
1.10	(28.0)	30	1.70	(43.2)	
1.05	(26.5)	36	1.65	(41.9)	
1.00	(25.5)	42	1.60	(40.6)	
0.95	(24.0)	48	1.55	(39.3)	
0.90	(23.0)	54	1.50	(38.1)	
0.85	(21.5)	60	1.45	(36.8)	
0.80	(20.5)	66	1.40	(35.5)	
0.75	(19.0)	72	1.35	(34.3)	
0.70	(18.0)	78	1.30	(33.0)	
0.65	(16.5)	84	1.25	(31.7)	
0.60	(15.0)	90	1.20	(30.5)	
0.55	(14.0)	95	1.15	(29.2)	
0.50	(12.5)	100	1.10	(27.9)	
0.45	(11.5)	105	1.05	(26.6)	
0.40	(10.0)	110	1.00	(25.4)	
0.35	(9.0)	115	0.95	(24.1)	
0.30	(7.5)	120	0.90	(22.8)	



**Track Shoes <sup>(1)</sup>  
Chopper**

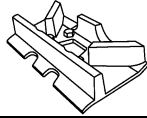

Depth Gauge			Ultrasonic	
Inches	(mm)	% Worn	Inches	(mm)
3.15	(80.0)	0	3.75	(95.3)
3.05	(77.5)	5	3.65	(92.7)
2.95	(75.0)	10	3.55	(90.2)
2.85	(72.5)	15	3.45	(87.6)
2.75	(70.0)	20	3.35	(85.1)
2.65	(67.5)	24	3.25	(82.6)
2.55	(65.0)	28	3.15	(80.0)
2.45	(62.0)	32	3.05	(77.5)
2.35	(59.5)	36	2.95	(74.9)
2.25	(57.0)	40	2.85	(72.4)
2.15	(54.5)	44	2.75	(69.9)
2.05	(52.0)	48	2.65	(67.3)
1.95	(49.5)	52	2.55	(64.8)
1.85	(47.0)	56	2.45	(62.2)
1.75	(44.5)	60	2.35	(59.7)
1.65	(42.0)	64	2.25	(57.2)
1.55	(39.5)	68	2.15	(54.6)
1.45	(37.0)	72	2.05	(52.1)
1.35	(34.5)	76	1.95	(49.5)
1.25	(31.5)	80	1.85	(47.0)
1.15	(29.0)	84	1.75	(44.5)
1.05	(26.5)	88	1.65	(41.9)
0.95	(24.0)	92	1.55	(39.4)
0.85	(21.5)	96	1.45	(36.8)
0.75	(19.0)	100	1.35	(34.3)
0.65	(16.5)	104	1.25	(31.7)
0.55	(14.0)	108	1.15	(29.2)
0.45	(11.5)	112	1.05	(26.7)
0.35	(9.0)	116	0.95	(24.1)
0.25	(6.5)	120	0.85	(21.6)

# 973 - 8.50 in. (215.9 mm)

## Idlers <sup>(1)</sup> <sup>(2)</sup> <sup>(3)</sup>

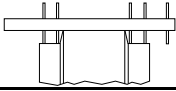

**Depth Gauge**

Inches	(mm)	% Worn
0.78	(20.0)	0
0.80	(20.5)	6
0.82	(21.0)	12
0.84	(21.5)	18
0.86	(22.0)	24
0.88	(22.5)	30
0.90	(23.0)	36
0.92	(23.5)	42
0.94	(24.0)	48
0.96	(24.5)	54
0.98	(25.0)	60
1.00	(25.5)	66
1.02	(26.0)	72
1.04	(26.5)	76
1.06	(27.0)	78
1.08	(27.5)	80
1.10	(28.0)	82
1.12	(28.5)	84
1.14	(29.0)	86
1.16	(29.5)	88
1.18	(30.0)	90
1.20	(30.5)	92
1.22	(31.0)	94
1.24	(31.5)	96
1.26	(32.0)	98
1.28	(32.5)	100
1.30	(33.0)	102
1.32	(33.5)	104
1.34	(34.0)	106
1.36	(34.5)	108
1.38	(35.0)	110
1.40	(35.5)	112
1.42	(36.0)	114
1.44	(36.5)	116
1.46	(37.0)	118
1.48	(37.5)	120

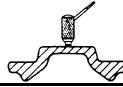

**Ultrasonic**

**Center Flange Wear**

Inches	(mm)	Inches	(mm)
0.48	(12.2)	0.00	(0.0)
0.46	(11.7)	0.02	(0.5)
0.44	(11.2)	0.04	(1.0)
0.42	(10.7)	0.06	(1.5)
0.40	(10.2)	0.08	(2.0)
0.38	(9.7)	0.10	(2.5)
0.36	(9.1)	0.12	(3.0)
0.34	(8.6)	0.14	(3.5)
0.32	(8.1)	0.16	(4.0)
0.30	(7.6)	0.18	(4.5)
0.28	(7.1)	0.20	(5.0)
0.26	(6.6)	0.22	(5.5)
0.24	(6.1)	0.24	(6.0)
0.22	(5.6)	0.26	(6.5)
0.20	(5.1)	0.28	(7.0)
0.18	(4.6)	0.30	(7.5)
0.16	(4.1)	0.32	(8.0)
0.14	(3.6)	0.34	(8.5)
0.12	(3.0)	0.36	(9.0)
0.10	(2.5)	0.38	(9.5)
0.08	(2.0)	0.40	(10.0)
0.06	(1.5)	0.42	(10.5)
0.04	(1.0)	0.44	(11.0)
0.02	(0.5)	0.46	(11.5)

### NOTE

Ultrasonic measurement is to determine flange wear only.

- 1 Flange width is 4.02 in. (102 mm)
- 2 New tread diameter is 29.61 in. (752 mm) or 27.09 in. (688 mm)
- 3 Wear Chart: 4421

**Carrier Rollers<sup>(1)</sup>  
SystemOne™**

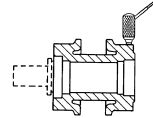
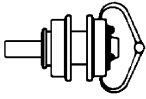

**Caliper  
All**

**Ultrasonic  
One-piece rim**

Inches	(mm)	% Worn	Inches	(mm)
7.84	(199.0)	0	2.31	(58.7)
7.76	(197.0)	8	2.27	(57.7)
7.68	(195.0)	16	2.23	(56.6)
7.60	(193.0)	24	2.19	(55.6)
7.52	(191.0)	32	2.15	(54.6)
7.44	(189.0)	40	2.11	(53.6)
7.36	(187.0)	44	2.07	(52.6)
7.28	(185.0)	48	2.03	(51.6)
7.20	(183.0)	52	1.99	(50.5)
7.12	(181.0)	56	1.95	(49.5)
7.04	(179.0)	60	1.91	(48.5)
6.96	(177.0)	64	1.87	(47.5)
6.88	(175.0)	68	1.83	(46.5)
6.80	(172.5)	72	1.79	(45.5)
6.72	(170.5)	76	1.75	(44.5)
6.64	(168.5)	80	1.71	(43.4)
6.56	(166.5)	84	1.67	(42.4)
6.48	(164.5)	88	1.63	(41.4)
6.40	(162.5)	92	1.59	(40.4)
6.32	(160.5)	96	1.55	(39.4)
6.24	(158.5)	100	1.51	(38.4)
6.16	(156.5)	104	1.47	(37.3)
6.08	(154.5)	108	1.43	(36.3)
6.00	(152.5)	112	1.39	(35.3)
5.92	(150.5)	116	1.35	(34.3)
5.84	(148.5)	120	1.31	(33.3)

**973 - 8.50 in. (215.9 mm)**

**Carrier Rollers <sup>(1)</sup>  
Conventional**

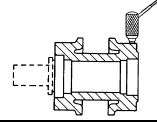
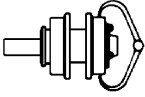

Caliper		% Worn	Ultrasonic	
Inches	(mm)		Inches	(mm)
7.50	(190.5)	0	1.92	(48.8)
7.42	(188.5)	8	1.88	(47.8)
7.34	(186.5)	16	1.84	(46.7)
7.26	(184.5)	24	1.80	(45.7)
7.18	(182.5)	32	1.76	(44.7)
7.10	(180.5)	40	1.72	(43.7)
7.02	(178.5)	48	1.68	(42.7)
6.94	(176.5)	52	1.64	(41.7)
6.86	(174.0)	56	1.60	(40.6)
6.78	(172.0)	60	1.56	(39.6)
6.70	(170.0)	64	1.52	(38.6)
6.62	(168.0)	68	1.48	(37.6)
6.54	(166.0)	72	1.44	(36.6)
6.46	(164.0)	76	1.40	(35.6)
6.38	(162.0)	80	1.36	(34.5)
6.30	(160.0)	84	1.32	(33.5)
6.22	(158.0)	88	1.28	(32.5)
6.14	(156.0)	92	1.24	(31.5)
6.06	(154.0)	96	1.20	(30.5)
5.98	(152.0)	100	1.16	(29.5)
5.90	(150.0)	104	1.12	(28.4)
5.82	(148.0)	108	1.08	(27.4)
5.74	(146.0)	112	1.04	(26.4)
5.66	(144.0)	116	1.00	(25.4)
5.58	(141.5)	120	0.96	(24.4)

1 Wear Chart: 4725

**Track Roller <sup>(1)</sup> <sup>(2)</sup>**  
**Rollers with End Collars or End Caps**

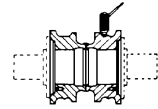
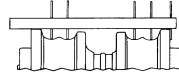
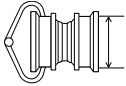

Caliper			Depth Gauge		Ultrasonic	
Inches	(mm)	% Worn	Inches	(mm)	Inches	(mm)
8.76	(222.5)	0	0.63	(16.0)	2.06	(52.3)
8.68	(220.5)	6	0.67	(17.0)	2.02	(51.3)
8.60	(218.5)	12	0.71	(18.0)	1.98	(50.3)
8.52	(216.5)	18	0.75	(19.0)	1.94	(49.3)
8.44	(214.5)	24	0.79	(20.0)	1.90	(48.3)
8.36	(212.5)	30	0.83	(21.0)	1.86	(47.2)
8.28	(210.5)	36	0.87	(22.0)	1.82	(46.2)
8.20	(208.5)	42	0.91	(23.0)	1.78	(45.2)
8.12	(206.0)	48	0.95	(24.0)	1.74	(44.2)
8.04	(204.0)	54	0.99	(25.0)	1.70	(43.2)
7.96	(202.0)	60	1.03	(26.0)	1.66	(42.2)
7.88	(200.0)	64	1.07	(27.0)	1.62	(41.1)
7.80	(198.0)	68	1.11	(28.0)	1.58	(40.1)
7.72	(196.0)	72	1.15	(29.0)	1.54	(39.1)
7.64	(194.0)	76	1.19	(30.0)	1.50	(38.1)
7.56	(192.0)	80	1.23	(31.0)	1.46	(37.1)
7.48	(190.0)	84	1.27	(32.5)	1.42	(36.1)
7.40	(188.0)	88	1.31	(33.5)	1.38	(35.1)
7.32	(186.0)	92	1.35	(34.5)	1.34	(34.0)
7.24	(184.0)	96	1.39	(35.5)	1.30	(33.0)
7.16	(182.0)	100	1.43	(36.5)	1.26	(32.0)
7.08	(180.0)	104	1.47	(37.5)	1.22	(31.0)
7.00	(178.0)	108	1.51	(38.5)	1.18	(30.0)
6.92	(176.0)	112	1.55	(39.5)	1.14	(29.0)
6.84	(173.5)	116	1.59	(40.5)	1.10	(27.9)
6.76	(171.5)	120	1.63	(41.5)	1.06	(26.9)

1 Flange diameter is 10.04 in. (255 mm)  
 2 Wear Chart: 5327

# 973 - 8.50 in. (215.9 mm)

## Track Rollers <sup>(1) (2)</sup> Rollers with Retainers

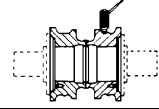
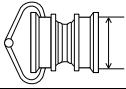

Caliper		% Worn	Depth Gauge		Ultrasonic	
Inches	(mm)		Inches	(mm)	Inches	(mm)
8.74	(222.0)	0	0.65	(16.5)	1.99	(50.5)
8.66	(220.0)	6	0.69	(17.5)	1.95	(49.5)
8.58	(218.0)	12	0.73	(18.5)	1.91	(48.5)
8.50	(216.0)	18	0.77	(19.5)	1.87	(47.5)
8.42	(214.0)	24	0.81	(20.5)	1.83	(46.5)
8.34	(212.0)	30	0.85	(21.5)	1.79	(45.5)
8.26	(210.0)	36	0.89	(22.5)	1.75	(44.5)
8.18	(208.0)	42	0.93	(23.5)	1.71	(43.4)
8.10	(205.5)	48	0.97	(24.5)	1.67	(42.4)
8.02	(203.5)	54	1.01	(25.5)	1.63	(41.4)
7.94	(201.5)	60	1.05	(26.5)	1.59	(40.4)
7.86	(199.5)	64	1.09	(27.5)	1.55	(39.4)
7.78	(197.5)	68	1.13	(28.5)	1.51	(38.4)
7.70	(195.5)	72	1.17	(29.5)	1.47	(37.3)
7.62	(193.5)	76	1.21	(30.5)	1.43	(36.3)
7.54	(191.5)	80	1.25	(32.0)	1.39	(35.3)
7.46	(189.5)	84	1.29	(33.0)	1.35	(34.3)
7.38	(187.5)	88	1.33	(34.0)	1.31	(33.3)
7.30	(185.5)	92	1.37	(35.0)	1.27	(32.3)
7.22	(183.5)	96	1.41	(36.0)	1.23	(31.2)
7.14	(181.5)	100	1.45	(37.0)	1.19	(30.2)
7.06	(179.5)	104	1.49	(38.0)	1.15	(29.2)
6.98	(177.5)	108	1.53	(39.0)	1.11	(28.2)
6.90	(175.5)	112	1.57	(40.0)	1.07	(27.2)
6.82	(173.0)	116	1.61	(41.0)	1.03	(26.2)
6.74	(171.0)	120	1.65	(42.0)	0.99	(25.1)

1 Flange diameter is 10.04 in. (255 mm)

2 Wear Chart: 5334

## Undercarriage Identification

The easiest way to identify track is to read the part number forged into the link. The following list cross-references link part numbers to the correct percent worn chart pages.

Model	Pitch	Link Part Number	Wear Chart Pages
304, 304.5, 305, 305.5, 305CR, 305C CR, 306, 306E	5.31 in. (135 mm)	158-4767 & 68 333-5628 & 25	From, page 597 – To, page 605
307, 308	5.31 in. (135 mm)	3A-9614 & 15 093-1969 & 70	From, page 606 – To, page 616
	6.06 in. (154 mm)	136-2404 & 10	
311, 312, 313, 314	6.75 in. (171.5 mm)	4I-7475 & 76 9K-6628 & 29	From, page 617 – To, page 626
313D2 LGP, 315, 316, 317, 318, 319, 320, 320 FM, 321, 322, 323, 324, TK711, 1090	7.50 in. (190 mm)	9W-3137 & 38 335-9246 & 47 106-1625 & 26 287-3118 & 19	From, page 628 – To, page 649
320 S, 322 FM, 323DS, 324 FM, 325, 325 FM, 511, 522, TK711, TK721, TK722, TK741 1090, 1190, 1390, 2390	8.00 in. (203.2 mm)	6Y-1607 & 08 8E-7405 & 06 261-1011 & 12 365-8401 & 02	From, page 650 – To, page 665
328, 330, 330FM, 336, 340, 532, 541, TK732	8.50 in. (215.9 mm)	6Y-2589 & 90 449-2675 & 76	From, page 667 – To, page 679
325D FM, 330 FM, 345, 349 551, 552, TK751, TK752	8.50 in. (215.9 mm)	150-4748 & 49 130-5333 & 34 209-6383 & 84 255-2364 & 65 305-9361 & 62 305-9363 & 64 390-9143 & 44	From, page 680 – To, page 691
345 FM, 350	9.00 in. (228.6 mm)	8E-6091 & 92 217-7681 & 82	From, page 693 – To, page 700
365, 374, 375, 385, 390, 5080, 5090	10.25 in. (260.4 mm)	142-1803 & 04 296-4361 & 62 6Y-6721 & 22 174-0217 & 18 296-4359 & 60	From, page 701 – To, page 713
5110	10.25 in. (260.4 mm)	9W-5933 & 34	From, page 715 – To, page 722
5130	12.50 in. (317.5 mm)	6I-8643 & 44 6T-8049 & 50	From, page 723 – To, page 731
5230	14.90 in. (378.5 mm)		From, page 733 – To, page 737

# Components

---

## Variables That Affect Wear Life

See the following pages for details on the effects of:

### Page

Controllable Variables	See, page 10
Track Adjustment	See, page 10
Shoe Width	See, page 11
Alignment	See, page 13
Non-Controllable Variables	See, page 17
Soil & Underfoot Conditions	See, page 17
Environmental Variables	See, page 19
Partially Controllable Variables	See, page 22

---

## Components

### Grease Lubricated Track

All current model Excavators are equipped with Grease Lubricated Track (GLT). These Tracks maintain the strength of the solid track pin and provide the added benefit of joint lubrication early in the life of the track. However, unlike Sealed and Lubricated Track, the GLT will not provide lubrication for the life of the track.

For as long as the GLT track joint retains the grease, there will be no internal wear of the bushing and pin. Once the grease lubrication is depleted, internal wear will begin in the same manner as Sealed Track. The length of time that the joints remain lubricated will vary with the Excavator model but generally, the lubricated life will range from 1200 to 2500 hours.

All measurements for the GLT continue to follow the procedures described below which are used to measure Sealed Track. In many cases, external bushing wear will now be the limiting wear factor compared to internal bushing wear for the Sealed Track.

### Links

See, page 24 through, page 30 for detailed link information.

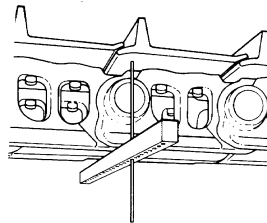

**Measurement** — Measure the track link over the centerline of the pin and bushing bores. See, page 24 for details.

**Wear Patterns** — See, page 24 through, page 29 for a detailed discussion of link wear patterns.

### Bushing — Sealed or Grease Lubricated Track — External

See, page 39 for details.



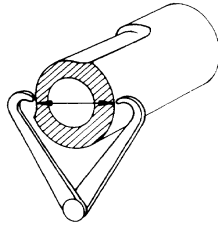

**Measurement** — To measure external wear use the caliper or the Ultrasonic Wear Indicator. Measure the minimum dimension regardless of the position (vertical, forward, reverse). This is because the Sealed Track bushing must have sufficient strength to resist cracking after the turn. The remaining strength is largely affected by wear before the turn. For details on measurement procedures, see, [page 39](#).

**Bushing External Allowable Wear** — Wear limits for Sealed Track bushings are determined by remaining strength before and after the turn as well as external wear. For high impact conditions use lesser allowable wear to service point. For low impact conditions use greater allowable wear to service point. Destruction is expected to occur within 20 percent of any additional hours if the same conditions exist

### Pin and Bushing — Sealed or Grease Lubricated Track — Internal

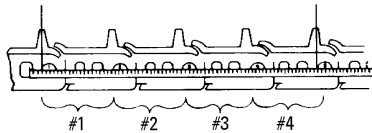

**Measurement** — Sealed track internal wear is measured by determining the pitch extended length over four adjacent sections with a tape measure calibrated in 0.02 in. (0.5 mm) increments. The track must be tight before measuring. Measure from the side of one pin to the same side of the fourth pin away (which includes 4 sections). See details on measurement procedure [on, page 39](#).

### Shoes

See, [page 44 through, page 47](#) for detailed shoe information.

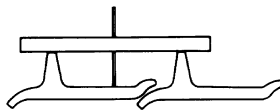

**Measurement** — Use the depth gauge or the Ultrasonic Wear Indicator to measure shoes.

**Bolt Torques** — Use the torque-turn tightening method [on, page 47](#).

## Components

Model	Bolt Size	Torque <sup>(1)</sup>
307, 308	1/2 in.	165 ±15 ft. lb. +1/3 turn 220 ±20 Nm +1/3 turn
311, 312, 313, 314	16 mm	130 ±30 ft. lb. +1/3 turn 175 ±40 Nm +1/3 turn
315, 317, 318, 319, 320, 321, 322, 323, 324, 325, 329	20 mm	300 ±50 ft. lb. +1/3 turn 400 ±70 Nm +1/3 turn
328, 330, 336, 350	22 mm	440 ±50 ft. lb. +1/3 turn 600 ±70 Nm +1/3 turn
330FM, 345, 349	24 mm	370 ±50 ft. lb. +1/3 turn 500 ±70 Nm +1/3 turn
365, 374, 375, 5080	27 mm	410 ±50 ft. lb. +1/3 turn 500 ±70 Nm +1/3 turn
385, 390, 5090	30 mm	675 ±70 ft. lb. +1/3 turn 900 ±100 Nm +1/3 turn
5110	1 1/8 in.	670 ±70 ft. lb. +1/3 turn 870 ±90 Nm +1/3 turn
5130	1 3/8 in.	1150 ±115 ft. lb. +1/3 turn 1500 ±150 Nm +1/3 turn

### Idlers

See, page 49 for detailed idler information.

**Measurement** — Use the depth gauge to measure idlers. On Fabricated Idlers only, the Ultrasonic Wear Indicator may be used to determine flange wear only.

### Carrier Rollers

See, page 53 through, page 55 for detailed carrier roller information.

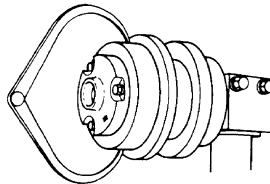

**Measurement** — Use the caliper or the Ultrasonic Wear Indicator to measure carrier rollers.

<sup>1</sup> See, page 29 and, page 47 for assembling and torque tightening procedures.

## Track Rollers

See, [page 56 through, page 59](#) for detailed track roller information.

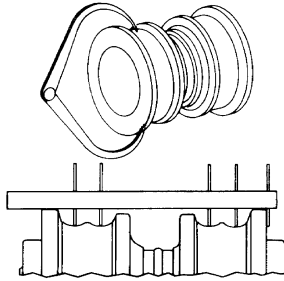

**Measurement** — Track rollers can be measured with either a depth gauge, a caliper or the Ultrasonic Wear Indicator. For instructions on how to make measurements, [see, page 56](#).

## Sprockets

See, [page 60 through, page 63](#) for detailed sprocket information.

### Sprocket Bolt Torque Specifications

Model	Bolt Size	Torque
307, 308	14 mm	130 ±20 ft. lb. 175 ±30 Nm
311, 312, 313, 314, 315, 317	16 mm	200 ±25 ft. lb. 270 ±40 Nm
318, 319, 320, 321, 322, 323, 324, 325, 329	20 mm	400 ±50 ft. lb. 530 ±70 Nm
328, 330, 336, 345, 349, 350	24 mm	670 ±75 ft. lb. 900 ±100 Nm
5090	30 mm	1500 ±185 ft. lb. 2000 ±250 Nm
365, 374, 375, 5080, 5130, 5230	30 mm	1330 ±150 ft. lb. 1800 ±200 Nm
385, 390	30 mm	1500 ±110 ft. lb. 2000 ±250 Nm

## Guards

See [Guards, page 64](#) for detailed information on track guiding guards and track roller guards.

### Track Shoe Supports for Forestry Applications

**Design Features** — Forestry applications for Hydraulic Excavators generally involve high impact and severe underfoot conditions. Full length track shoe supports mounted to the track roller frame are recommended to limit the torsional loads experienced by the link assembly.

As the machine rides over objects such as rocks or stumps, the track shoe deflects and the track chain begins to twist. With track shoe supports, the shoes contact the support and prevent further twisting of the chain. These supports limit the loads going into the link assembly and significantly reduce the occurrence of link cracking and track pin walking.

## Components

The contact between the shoe support and the leading edge of the track shoes results in accelerated wear on the leading edge of the shoes. However, the gains made in link assembly life more than off-set the detrimental effects of leading edge wear on the shoes.

**Installation Guidelines** — To provide proper performance of the track shoe supports, recommended installation dimensions are shown below. The dimension shown in the illustration for the clearance between the support and the track shoe is the dimension to the shoe plate surface. (It is not the distance to the leading edge of the shoe.)

If the supports are located too far from the shoe surface, they will not provide the proper protection for the link assembly. If the supports are too close to the shoes, high shoe wear and high friction (i. e. draw-bar reduction) will occur.

**Maintenance** — When link assemblies are replaced, it is essential to inspect the track shoe supports and to rebuild them to the original dimensions if required. Operating new link assemblies with significantly worn or damaged shoe supports will result in reduced link assembly life. Clearance dimensions should be checked after the new link assemblies are installed.

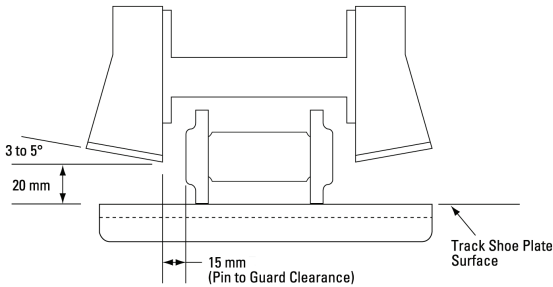

## Excavator Track Adjustment



**Grease is under high pressure.**

**Grease coming out of the relief valve under pressure can penetrate the body causing injury or death.**

**Do not watch the relief valve to see if grease is escaping. Watch the track or track adjustment cylinder to see if the track is being loosened.**

- 1 Operate the machine in the direction of the idlers.
- 2 Stop with one track pin directly over the front carrier roller. Park the machine and turn off the engine.

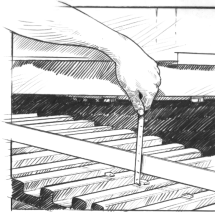

- 3 Place a tight line or straight edge on top of the grousers between the front carrier roller and idler. The straight edge should be long enough to reach from the front carrier roller to the idler.

**Note:** If the machine is equipped with three carrier rollers, place a straight edge on the tracks between the carrier rollers. The straight edge should be long enough to reach from one carrier roller to another carrier roller.

Measure the maximum amount of sag in the track. The sag is measured from the highest point of the grouser tip to the bottom of the straight edge, midway between the front carrier roller and idler.

Refer to the following chart to determine the correct sag for each model.

- 4 If the track is too tight, loosen it by opening the relief valve and allowing grease to escape.

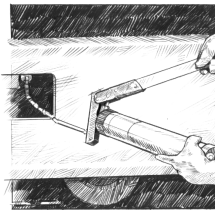

- 5 Tighten track by adding grease at the hydraulic fill and relief valve. Travel in forward and reverse to equalize tension through-out the track. Then reinspect adjustment.

### Proper Track Sag

Model	Minimum	Target	Maximum
All 300 Family series excavators	1.6 in. (40 mm)	1.85 in. (47.5 mm)	2.1 in. (55 mm)
5080, 5090B	1.6 in. (40 mm)	1.85 in. (47.5 mm)	2.1 in. (55 mm)



# 304, 304.5, 305, 305.5, 306 - 5.31 in. (135 mm)

**Track Links <sup>(1)</sup>  
Unsealed Track  
158-4767 & 68  
333-5628 & 25**

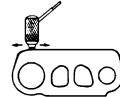
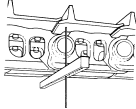

Depth Gauge			Ultrasonic	
Inches	(mm)	% Worn	Inches	(mm)
2.63	(67.0)	0	0.73	(18.5)
2.61	(66.5)	10	0.71	(18.0)
2.59	(66.0)	20	0.69	(17.5)
2.57	(65.5)	30	0.67	(17.0)
2.55	(65.0)	40	0.65	(16.5)
2.53	(64.5)	50	0.63	(16.0)
2.51	(64.0)	60	0.61	(15.5)
2.49	(63.0)	68	0.59	(15.0)
2.47	(62.5)	76	0.57	(14.5)
2.45	(62.0)	84	0.55	(14.0)
2.43	(61.5)	92	0.53	(13.5)
2.41	(61.0)	100	0.51	(13.0)
2.39	(60.5)	108	0.49	(12.4)
2.37	(60.0)	116	0.47	(11.9)
2.35	(59.5)	124	0.45	(11.4)

**304, 304.5, 305, 305.5, 306 - 5.31 in. (135 mm)**

**Pins and Bushings <sup>(1)</sup>  
Internal Wear  
Sealed Track**

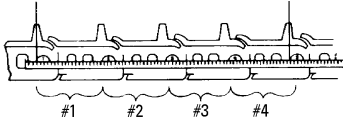

**Depth Gauge**

Inches	(mm)	% Worn
21.25	(540.0)	0
21.30	(541.0)	10
21.35	(542.5)	20
21.40	(543.5)	30
21.45	(545.0)	40
21.50	(546.0)	50
21.55	(547.5)	60
21.60	(548.5)	70
21.65	(550.0)	80
21.70	(551.0)	90
21.75	(552.5)	100
21.80	(553.5)	105
21.85	(555.0)	110
21.90	(556.5)	115
21.95	(557.5)	120

1 Wear Chart: 300



# 304, 304.5, 305, 305.5, 306 - 5.31 in. (135 mm)

## Bushings <sup>(1)</sup> External Wear Sealed Track

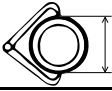

Caliper		Lesser	Ultrasonic	
Inches	(mm)	% Worn	Inches	(mm)
1.37	(34.8)	0	0.24	(6.1)
1.36	(34.5)	9	0.23	(5.8)
1.35	(34.3)	18	0.22	(5.6)
1.34	(34.0)	27	0.21	(5.3)
1.33	(33.8)	36	0.20	(5.1)
1.32	(33.5)	45	0.19	(4.8)
1.31	(33.3)	54	0.18	(4.6)
1.30	(33.0)	63	0.17	(4.3)
1.29	(32.8)	72	0.16	(4.1)
1.28	(32.5)	81	0.15	(3.8)
1.27	(32.3)	90	0.14	(3.6)
1.26	(32.0)	95	0.13	(3.3)
1.25	(31.8)	100	0.12	(3.0)
1.24	(31.5)	105	0.11	(2.8)
1.23	(31.2)	110	0.10	(2.5)
1.22	(31.0)	115	0.09	(2.3)
1.21	(30.7)	120	0.08	(2.0)

**304, 304.5, 305, 305.5, 306 - 5.31 in. (135 mm)**

**Track Shoes <sup>(1)</sup>  
Triple Grouser**

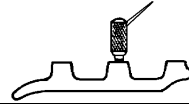
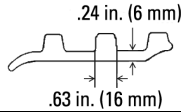
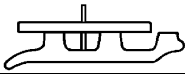

Depth Gauge			Ultrasonic	
Inches	(mm)	% Worn	Inches	(mm)
0.55	(14.0)	0	0.79	(20.0)
0.53	(13.5)	7	0.77	(19.5)
0.51	(13.0)	14	0.75	(19.0)
0.49	(12.5)	21	0.73	(18.5)
0.47	(12.0)	28	0.71	(18.0)
0.45	(11.5)	35	0.69	(17.5)
0.43	(11.0)	42	0.67	(17.0)
0.41	(10.5)	49	0.65	(16.4)
0.39	(10.0)	56	0.63	(15.9)
0.37	(9.5)	63	0.61	(15.4)
0.35	(9.0)	70	0.59	(14.9)
0.33	(8.5)	76	0.57	(14.4)
0.31	(8.0)	82	0.55	(13.9)
0.29	(7.5)	88	0.53	(13.4)
0.27	(7.0)	94	0.51	(12.9)
0.25	(6.5)	100	0.49	(12.4)
0.23	(6.0)	106	0.47	(11.9)
0.21	(5.5)	112	0.45	(11.4)
0.19	(5.0)	118	0.43	(10.9)
0.17	(4.5)	124	0.41	(10.3)

**Idlers** (1) (2) (3)

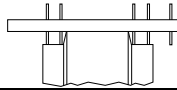

**Depth Gauge**

Inches	(mm)	% Worn
0.88	(22.5)	0
0.90	(23.0)	12
0.92	(23.5)	24
0.94	(24.0)	36
0.96	(24.5)	48
0.98	(25.0)	60
1.00	(25.5)	68
1.02	(26.0)	76
1.04	(26.5)	84
1.06	(27.0)	92
1.08	(27.5)	100
1.10	(28.0)	108
1.12	(28.5)	116
1.14	(29.0)	124

- 1 Flange width is 1.97 in. (50 mm)
- 2 New tread diameter is 13.19 in. (335 mm)
- 3 Wear Chart: 4305

**304CR, 304.5, 305.5, 306 - 5.31 in. (135 mm)**

**Carrier Rollers <sup>(1)</sup>  
Current Carrier Roller**

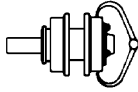

**Caliper  
All**

<b>Inch</b>	<b>(mm)</b>	<b>% Worn</b>
3.34	(85.0)	0
3.32	(84.5)	7
3.30	(84.0)	14
3.28	(83.5)	21
3.26	(83.0)	28
3.24	(82.5)	35
3.22	(82.0)	42
3.20	(81.5)	49
3.18	(81.0)	56
3.16	(80.5)	60
3.14	(80.0)	64
3.12	(79.0)	68
3.10	(78.5)	72
3.08	(78.0)	76
3.06	(77.5)	80
3.04	(77.0)	84
3.02	(76.5)	88
3.00	(76.0)	92
2.98	(75.5)	96
2.96	(75.0)	100
2.94	(74.5)	104
2.92	(74.0)	108
2.90	(73.5)	112
2.88	(73.0)	116
2.86	(72.5)	120

1 Wear Chart: 4603

Carrier Rollers <sup>(1)</sup>

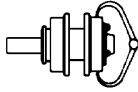

Caliper  
All

Inch	(mm)	% Worn
2.74	(69.5)	0
2.72	(69.0)	8
2.70	(68.5)	16
2.68	(68.0)	24
2.66	(67.5)	32
2.64	(67.0)	40
2.62	(66.5)	48
2.60	(66.0)	56
2.58	(65.5)	64
2.56	(65.0)	72
2.54	(64.5)	80
2.52	(64.0)	85
2.50	(63.5)	90
2.48	(63.0)	95
2.46	(62.5)	100
2.44	(62.0)	105
2.42	(61.5)	110
2.40	(61.0)	115
2.38	(60.5)	120

### 304 CR, 304.5, 305 CR - 5.31 in. (135 mm)

#### Carrier Rollers <sup>(1)</sup> Early Carrier Roller

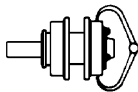

#### Caliper All

Inches	(mm)	% Worn
3.14	(80.0)	0
3.12	(79.0)	7
3.10	(78.5)	14
3.08	(78.0)	21
3.06	(77.5)	28
3.04	(77.0)	35
3.02	(76.5)	42
3.00	(76.0)	48
2.98	(75.5)	52
2.96	(75.0)	56
2.94	(74.5)	60
2.92	(74.0)	64
2.90	(73.5)	68
2.88	(73.0)	72
2.86	(72.5)	76
2.84	(72.0)	80
2.82	(71.5)	84
2.80	(71.0)	88
2.78	(70.5)	92
2.76	(70.0)	96
2.74	(69.5)	100
2.72	(69.0)	104
2.70	(68.5)	108
2.68	(68.0)	112
2.66	(67.5)	116
2.64	(67.0)	120

1 Wear Chart: 4602

# 304, 304.5, 305, 305.5, 306 - 5.31 in. (135 mm)

## Track Rollers <sup>(1)</sup> <sup>(2)</sup>



Caliper			Depth Gauge	
Inches	(mm)	% Worn	Inches	(mm)
3.93	(100.0)	0	0.67	(17.0)
3.91	(99.5)	6	0.68	(17.5)
3.89	(99.0)	12	0.69	(17.5)
3.87	(98.5)	18	0.70	(18.0)
3.85	(98.0)	24	0.71	(18.0)
3.83	(97.5)	30	0.72	(18.5)
3.81	(97.0)	36	0.73	(18.5)
3.79	(96.5)	42	0.74	(19.0)
3.77	(96.0)	48	0.75	(19.0)
3.75	(95.5)	52	0.76	(19.5)
3.73	(94.5)	56	0.77	(19.5)
3.71	(94.0)	60	0.78	(20.0)
3.69	(93.5)	64	0.79	(20.0)
3.67	(93.0)	68	0.80	(20.5)
3.65	(92.5)	72	0.81	(20.5)
3.63	(92.0)	76	0.82	(21.0)
3.61	(91.5)	80	0.83	(21.0)
3.59	(91.0)	84	0.84	(21.5)
3.57	(90.5)	88	0.85	(21.5)
3.55	(90.0)	92	0.86	(22.0)
3.53	(89.5)	96	0.87	(22.0)
3.51	(89.0)	100	0.88	(22.5)
3.49	(88.5)	104	0.89	(22.5)
3.47	(88.0)	108	0.90	(23.0)
3.45	(87.5)	112	0.91	(23.0)
3.43	(87.0)	116	0.92	(23.5)
3.41	(86.5)	120	0.93	(23.5)

1 Flange diameter is 5.28 in. (134.1 mm)

2 Wear Chart: 5204

# 307, 308 - 6.06 in. (154 mm), 5.31 in. (135 mm)

## Track Links <sup>(1)</sup> Greased Lubricated Track 136-2404 & 10 093-1969 & 70 3A-9614 & 15

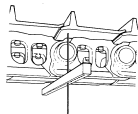

Depth Gauge			Ultrasonic	
Inches	(mm)	% Worn	Inches	(mm)
2.91	(74.0)	0	0.78	(19.8)
2.89	(73.5)	9	0.76	(19.3)
2.87	(73.0)	18	0.74	(18.8)
2.85	(72.5)	27	0.72	(18.3)
2.83	(72.0)	36	0.70	(17.8)
2.81	(71.5)	45	0.68	(17.3)
2.79	(71.0)	54	0.66	(16.8)
2.77	(70.5)	63	0.64	(16.3)
2.75	(70.0)	72	0.62	(15.7)
2.73	(69.5)	79	0.60	(15.2)
2.71	(69.0)	86	0.58	(14.7)
2.69	(68.5)	93	0.56	(14.2)
2.67	(68.0)	100	0.54	(13.7)
2.65	(67.5)	107	0.52	(13.2)
2.63	(67.0)	114	0.50	(12.7)
2.61	(66.5)	121	0.48	(12.2)



**Pins and Bushings <sup>(1)</sup>  
Internal Wear  
Sealed Track  
Grease Lubricated Track  
6.06 in. (154 mm) Pitch**

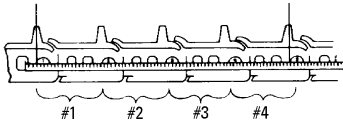

**Depth Gauge**

Inches	(mm)	% Worn
24.25	(616.0)	0
24.30	(617.0)	10
24.35	(618.5)	20
24.40	(620.0)	30
24.45	(621.0)	40
24.50	(622.5)	50
24.55	(623.5)	60
24.60	(625.0)	70
24.65	(626.0)	80
24.70	(627.5)	90
24.75	(628.5)	100
24.80	(630.0)	105
24.85	(631.0)	110
24.90	(632.5)	115
24.95	(633.5)	120

**Pins and Bushings <sup>(1)</sup>**  
**Internal Wear**  
**Sealed Track**  
**Grease Lubricated Track**  
**5.31 in. (135 mm) Pitch**

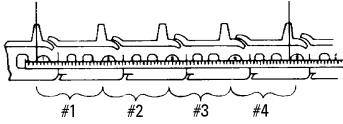

<b>Depth Gauge</b>		
<b>Inches</b>	<b>(mm)</b>	<b>% Worn</b>
21.25	(540.0)	0
21.30	(541.2)	10
21.35	(542.3)	20
21.40	(543.6)	30
21.45	(544.8)	40
21.50	(546.1)	50
21.55	(547.3)	60
21.60	(548.6)	70
21.65	(549.9)	80
21.70	(551.2)	90
21.75	(552.4)	100
21.80	(553.7)	105
21.85	(555.0)	110
21.90	(556.2)	115
21.95	(557.5)	120

1 Wear Chart: 300

# 307, 308 - 6.06 in. (154 mm), 5.31 in. (135 mm)

## Bushings <sup>(1)</sup> External Wear Sealed Track Grease Lubricated Track

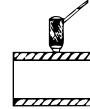

Caliper			Ultrasonic	
Inches	(mm)	% Worn	Inches	(mm)
1.61	(40.9)	0	0.32	(8.1)
1.60	(40.6)	8	0.31	(7.9)
1.59	(40.4)	16	0.30	(7.6)
1.58	(40.1)	24	0.29	(7.4)
1.57	(39.9)	32	0.28	(7.1)
1.56	(39.6)	40	0.27	(6.9)
1.55	(39.4)	48	0.26	(6.6)
1.54	(39.1)	56	0.25	(6.4)
1.53	(38.9)	64	0.24	(6.1)
1.52	(38.6)	72	0.23	(5.8)
1.51	(38.4)	80	0.22	(5.6)
1.50	(38.1)	84	0.21	(5.3)
1.49	(37.8)	88	0.20	(5.1)
1.48	(37.6)	92	0.19	(4.8)
1.47	(37.3)	96	0.18	(4.6)
1.46	(37.1)	100	0.17	(4.3)
1.45	(36.8)	104	0.16	(4.1)
1.44	(36.6)	108	0.15	(3.8)
1.43	(36.3)	112	0.14	(3.6)
1.42	(36.1)	116	0.13	(3.3)
1.41	(35.8)	120	0.12	(3.0)

**307, 308 - 6.06 in. (154 mm)**

**Track Shoes <sup>(1)</sup>  
Triple Grouser  
6.06 in. (154 mm) Pitch**

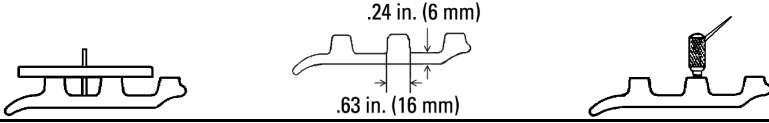

Depth Gauge			Ultrasonic	
Inches	(mm)	% Worn	Inches	(mm)
0.79	(20.0)	0	1.02	(25.9)
0.77	(19.5)	4	1.00	(25.4)
0.75	(19.0)	8	0.98	(24.9)
0.73	(18.5)	12	0.96	(24.4)
0.71	(18.0)	16	0.94	(23.9)
0.69	(17.5)	20	0.92	(23.4)
0.67	(17.0)	24	0.90	(22.9)
0.65	(16.5)	28	0.88	(22.4)
0.63	(16.0)	32	0.86	(21.8)
0.61	(15.5)	36	0.84	(21.3)
0.59	(15.0)	40	0.82	(20.8)
0.57	(14.5)	44	0.80	(20.3)
0.55	(14.0)	48	0.78	(19.8)
0.53	(13.5)	52	0.76	(19.3)
0.51	(13.0)	56	0.74	(18.8)
0.49	(12.5)	60	0.72	(18.3)
0.47	(12.0)	64	0.70	(17.8)
0.45	(11.5)	68	0.68	(17.3)
0.43	(11.0)	72	0.66	(16.8)
0.41	(10.5)	76	0.64	(16.3)
0.39	(10.0)	79	0.62	(15.7)
0.37	(9.5)	82	0.60	(15.2)
0.35	(9.0)	85	0.58	(14.7)
0.33	(8.5)	88	0.56	(14.2)
0.31	(8.0)	91	0.54	(13.7)
0.29	(7.5)	94	0.52	(13.2)
0.27	(7.0)	97	0.50	(12.7)
0.25	(6.5)	100	0.48	(12.2)
0.23	(6.0)	103	0.46	(11.7)
0.21	(5.5)	106	0.44	(11.2)
0.19	(5.0)	109	0.42	(10.7)
0.17	(4.5)	112	0.40	(10.2)
0.15	(4.0)	115	0.38	(9.7)
0.13	(3.5)	118	0.36	(9.1)
0.11	(3.0)	121	0.34	(8.6)

**Track Shoes <sup>(1)</sup>  
Triple Grouser  
5.31 in. (135 mm) Pitch**

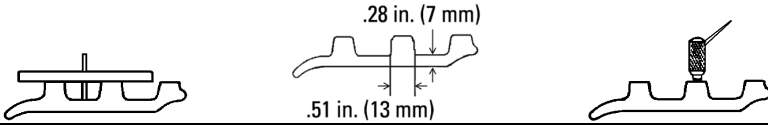

Depth Gauge			Ultrasonic	
Inches	(mm)	% Worn	Inches	(mm)
0.55	(14.0)	0	0.83	(21.1)
0.53	(13.5)	7	0.81	(20.6)
0.51	(13.0)	14	0.79	(20.1)
0.49	(12.5)	21	0.77	(19.6)
0.47	(12.0)	28	0.75	(19.1)
0.45	(11.5)	35	0.73	(18.5)
0.43	(11.0)	42	0.71	(18.0)
0.41	(10.5)	49	0.69	(17.5)
0.39	(10.0)	56	0.67	(17.0)
0.37	(9.5)	63	0.65	(16.5)
0.35	(9.0)	70	0.63	(16.0)
0.33	(8.5)	76	0.61	(15.5)
0.31	(8.0)	82	0.59	(15.0)
0.29	(7.5)	88	0.57	(14.5)
0.27	(7.0)	94	0.55	(14.0)
0.25	(6.5)	100	0.53	(13.5)
0.23	(6.0)	106	0.51	(13.0)
0.21	(5.5)	112	0.49	(12.4)
0.19	(5.0)	118	0.47	(11.9)
0.17	(4.5)	124	0.45	(11.4)

### 308C, 308D - 6.06 in. (154 mm)

Idlers <sup>(1)</sup> <sup>(2)</sup> <sup>(3)</sup>  
 "Peaked" Center Flange Idler  
 6.06 (154 mm) Pitch only

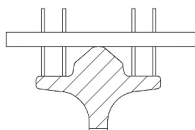

#### Depth Gauge

Inches	(mm)	% Worn
1.02	(26.0)	0
1.04	(26.5)	14
1.06	(27.0)	28
1.08	(27.5)	42
1.10	(28.0)	52
1.12	(28.5)	60
1.14	(29.0)	68
1.16	(29.5)	76
1.18	(30.0)	84
1.20	(30.5)	92
1.22	(31.0)	100
1.24	(31.5)	108
1.26	(32.0)	116
1.28	(32.5)	124

- 1 Flange width is 1.69 in. (43 mm)
- 2 New tread diameter is 15.75 in. (400 mm)
- 3 Wear Chart: 4304

**Idlers <sup>(1)</sup> <sup>(2)</sup> <sup>(3)</sup>**  
**Flat Center Flange Idler**  
**6.06 in. (154 mm) Pitch only**

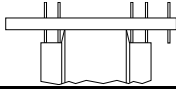

**Depth Gauge**

<b>Inches</b>	<b>(mm)</b>	<b>% Worn</b>
0.52	(13.0)	0
0.54	(13.5)	14
0.56	(14.0)	28
0.58	(14.5)	42
0.60	(15.0)	52
0.62	(15.5)	60
0.64	(16.5)	68
0.66	(17.0)	76
0.68	(17.5)	84
0.70	(18.0)	92
0.72	(18.5)	100
0.74	(19.0)	108
0.76	(19.5)	116
0.78	(20.0)	124

- 1 Flange width is 1.69 in. (43 mm)
- 2 New tread diameter is 15.75 in. (400 mm)
- 3 Wear Chart: 4302

## 307 - 5.31 in. (135 mm)

Idlers <sup>(1)</sup> <sup>(2)</sup> <sup>(3)</sup>  
5.31 in. (135 mm) Pitch, All

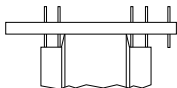

Depth Gauge

Inches	(mm)	% Worn
0.86	(22.0)	0
0.88	(22.5)	14
0.90	(23.0)	28
0.92	(23.5)	42
0.94	(24.0)	52
0.96	(24.5)	60
0.98	(25.0)	68
1.00	(25.5)	76
1.02	(26.0)	84
1.04	(26.5)	92
1.06	(27.0)	100
1.08	(27.5)	108
1.10	(28.0)	116
1.12	(28.5)	124

- 1 Flange width is 1.69 in. (43 mm)
- 2 New tread diameter is 15.75 in. (400 mm)
- 3 Wear Chart: 4301



## 307, 308 - 6.06 in. (154 mm), 5.31 in. (135 mm)

### Carrier Rollers <sup>(1)</sup>

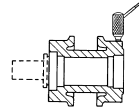
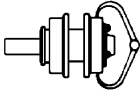

**Caliper  
All**

**Ultrasonic  
One-piece rim**

Inches	(mm)	% Worn	Inches	(mm)
3.34	(85.0)	0	0.77	(19.6)
3.32	(84.5)	6	0.76	(19.3)
3.30	(84.0)	12	0.75	(19.1)
3.28	(83.5)	18	0.74	(18.8)
3.26	(83.0)	24	0.73	(18.5)
3.24	(82.5)	30	0.72	(18.3)
3.22	(82.0)	36	0.71	(18.0)
3.20	(81.5)	42	0.70	(17.8)
3.18	(81.0)	48	0.69	(17.5)
3.16	(80.5)	54	0.68	(17.3)
3.14	(80.0)	60	0.67	(17.0)
3.12	(79.0)	64	0.66	(16.8)
3.10	(78.5)	68	0.65	(16.5)
3.08	(78.0)	72	0.64	(16.3)
3.06	(77.5)	76	0.63	(16.0)
3.04	(77.0)	80	0.62	(15.7)
3.02	(76.5)	84	0.61	(15.5)
3.00	(76.0)	88	0.60	(15.2)
2.98	(75.5)	92	0.59	(15.0)
2.96	(75.0)	96	0.58	(14.7)
2.94	(74.5)	100	0.57	(14.5)
2.92	(74.0)	104	0.56	(14.2)
2.90	(73.5)	108	0.55	(14.0)
2.88	(73.0)	112	0.54	(13.7)
2.86	(72.5)	116	0.53	(13.5)
2.84	(72.0)	120	0.52	(13.2)

**NOTE**

This Carrier Roller is manufactured with cast iron. Using ultrasonic may be less accurate than calipers.

**307, 308 - 6.06 in. (154 mm), 5.31 in. (135 mm)**

**Track Rollers <sup>(1)</sup>  
Single Flange/Center Flange <sup>(2)</sup>**

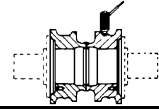

Caliper		% Worn	Depth Gauge		Ultrasonic	
Inches	(mm)		Inches	(mm)	Inches	(mm)
4.72	(120.0)	0	0.47	(12.0)	1.49	(37.8)
4.70	(119.5)	5	0.48	(12.0)	1.48	(37.6)
4.68	(119.0)	10	0.49	(12.5)	1.47	(37.3)
4.66	(118.5)	15	0.50	(12.5)	1.46	(37.1)
4.64	(118.0)	20	0.51	(13.0)	1.45	(36.8)
4.62	(117.5)	25	0.52	(13.0)	1.44	(36.6)
4.60	(117.0)	30	0.53	(13.5)	1.43	(36.3)
4.58	(116.5)	35	0.54	(13.5)	1.42	(36.1)
4.56	(116.0)	40	0.55	(14.0)	1.41	(35.8)
4.54	(115.5)	45	0.56	(14.0)	1.40	(35.6)
4.52	(115.0)	50	0.57	(14.5)	1.39	(35.3)
4.50	(114.5)	55	0.58	(14.5)	1.38	(35.1)
4.48	(114.0)	60	0.59	(15.0)	1.37	(34.8)
4.46	(113.5)	64	0.60	(15.0)	1.36	(34.5)
4.44	(113.0)	67	0.61	(15.5)	1.35	(34.3)
4.42	(112.5)	70	0.62	(15.5)	1.34	(34.0)
4.40	(112.0)	73	0.63	(16.0)	1.33	(33.8)
4.38	(111.5)	76	0.64	(16.5)	1.32	(33.5)
4.36	(110.5)	79	0.65	(16.5)	1.31	(33.3)
4.34	(110.0)	82	0.66	(17.0)	1.30	(33.0)
4.32	(109.5)	85	0.67	(17.0)	1.29	(32.8)
4.30	(109.0)	88	0.68	(17.5)	1.28	(32.5)
4.28	(108.5)	91	0.69	(17.5)	1.27	(32.3)
4.26	(108.0)	94	0.70	(18.0)	1.26	(32.0)
4.24	(107.5)	97	0.71	(18.0)	1.25	(31.8)
4.22	(107.0)	100	0.72	(18.5)	1.24	(31.5)
4.20	(106.5)	103	0.73	(18.5)	1.23	(31.2)
4.18	(106.0)	106	0.74	(19.0)	1.22	(31.0)
4.16	(105.5)	109	0.75	(19.0)	1.21	(30.7)
4.14	(105.0)	112	0.76	(19.5)	1.20	(30.5)
4.12	(104.5)	115	0.77	(19.5)	1.19	(30.2)
4.10	(104.0)	118	0.78	(20.0)	1.18	(30.0)
4.08	(103.5)	121	0.79	(20.0)	1.17	(29.7)

1 Wear Chart: 5202

2 Note: Do not measure center flange rollers with depth gauge.

Track Links <sup>(1)</sup>  
Grease Lubricated Track  
9K-6628 & 29

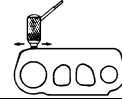
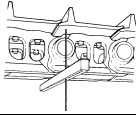

Depth Gauge			Ultrasonic		
Inches	(mm)	% Worn	Inches	(mm)	
3.75	(95.5)	0	1.00	(25.4)	
3.73	(94.5)	9	0.98	(24.9)	
3.71	(94.0)	18	0.96	(24.4)	
3.69	(93.5)	27	0.94	(23.9)	
3.67	(93.0)	36	0.92	(23.4)	
3.65	(92.5)	45	0.90	(22.9)	
3.63	(92.0)	54	0.88	(22.4)	
3.61	(91.5)	63	0.86	(21.8)	
3.59	(91.0)	72	0.84	(21.3)	
3.57	(90.5)	79	0.82	(20.8)	
3.55	(90.0)	86	0.80	(20.3)	
3.53	(89.5)	93	0.78	(19.8)	
3.51	(89.0)	100	0.76	(19.3)	
3.49	(88.5)	107	0.74	(18.8)	
3.47	(88.0)	114	0.72	(18.3)	
3.45	(87.5)	121	0.70	(17.8)	

# 311, 312, 313, 314 - 6.75 in. (171.5 mm)

## Track Links <sup>(1)</sup> Sealed Track, Grease Lubricated Track 4I-7475 & 76

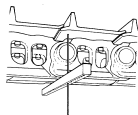

Depth Gauge			Ultrasonic		
Inches	(mm)	% Worn	Inches	(mm)	
3.54	(90.0)	0	0.97	(24.6)	
3.52	(89.5)	9	0.95	(24.1)	
3.50	(89.0)	18	0.93	(23.6)	
3.48	(88.5)	27	0.91	(23.1)	
3.46	(88.0)	36	0.89	(22.6)	
3.44	(87.5)	45	0.87	(22.1)	
3.42	(87.0)	54	0.85	(21.6)	
3.40	(86.5)	63	0.83	(21.1)	
3.38	(86.0)	72	0.81	(20.6)	
3.36	(85.5)	79	0.79	(20.1)	
3.34	(85.0)	86	0.77	(19.6)	
3.32	(84.5)	93	0.75	(19.1)	
3.30	(84.0)	100	0.73	(18.5)	
3.28	(83.5)	107	0.71	(18.0)	
3.26	(83.0)	114	0.69	(17.5)	
3.24	(82.5)	121	0.67	(17.0)	

**Pins and Bushings <sup>(1)</sup>**  
**Internal Wear**  
**Sealed Track**  
**Grease Lubricated Track**

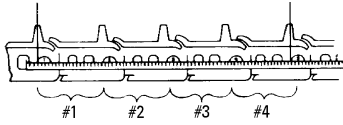

Inches	(mm)	% Worn
27.00	(686.0)	0
27.05	(687.0)	10
27.10	(688.5)	20
27.15	(689.5)	30
27.20	(691.0)	40
27.25	(692.0)	50
27.30	(693.5)	60
27.35	(694.5)	70
27.40	(696.0)	80
27.45	(697.0)	90
27.50	(698.5)	100
27.55	(700.0)	105
27.60	(701.0)	110
27.65	(702.5)	115
27.70	(703.5)	120

# 312B, 312C - 6.75 in. (171.5 mm)

**Bushings <sup>(1)</sup>  
External Wear  
Grease Lubricated Track  
Use with 9K-6628 & 29 Links**

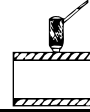

Caliper			Ultrasonic	
Inches	(mm)	% Worn	Inches	(mm)
2.14	(54.4)	0	0.39	(9.9)
2.13	(54.1)	6	0.38	(9.7)
2.12	(53.8)	12	0.37	(9.4)
2.11	(53.6)	18	0.36	(9.1)
2.10	(53.3)	24	0.35	(8.9)
2.09	(53.1)	30	0.34	(8.6)
2.08	(52.8)	36	0.33	(8.4)
2.07	(52.6)	42	0.32	(8.1)
2.06	(52.3)	48	0.31	(7.9)
2.05	(52.1)	54	0.30	(7.6)
2.04	(51.8)	60	0.29	(7.4)
2.03	(51.6)	64	0.28	(7.1)
2.02	(51.3)	67	0.27	(6.9)
2.01	(51.1)	70	0.26	(6.6)
2.00	(50.8)	73	0.25	(6.4)
1.99	(50.5)	76	0.24	(6.1)
1.98	(50.3)	79	0.23	(5.8)
1.97	(50.0)	82	0.22	(5.6)
1.96	(49.8)	85	0.21	(5.3)
1.95	(49.5)	88	0.20	(5.1)
1.94	(49.3)	91	0.19	(4.8)
1.93	(49.0)	94	0.18	(4.6)
1.92	(48.8)	97	0.17	(4.3)
1.91	(48.5)	100	0.16	(4.1)
1.90	(48.3)	103	0.15	(3.8)
1.89	(48.0)	106	0.14	(3.6)
1.88	(47.8)	109	0.13	(3.3)
1.87	(47.5)	112	0.12	(3.0)
1.86	(47.2)	115	0.11	(2.8)
1.85	(47.0)	118	0.10	(2.5)
1.84	(46.7)	121	0.09	(2.3)

1 Wear Chart: 944

# 311, 312, 313, 314 - 6.75 in. (171.5 mm)

**Bushings <sup>(1)</sup>**  
**External Wear**  
**Sealed Track**  
**Grease Lubricated Track**  
**Use with 4I-7475 & 76 Links**

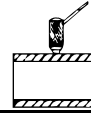
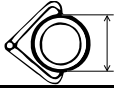

Caliper			Ultrasonic		
Inches	(mm)	% Worn	Inches	(mm)	
1.99	(50.5)	0	0.32	(8.1)	
1.98	(50.3)	8	0.31	(7.9)	
1.97	(50.0)	16	0.30	(7.6)	
1.96	(49.8)	24	0.29	(7.4)	
1.95	(49.5)	32	0.28	(7.1)	
1.94	(49.3)	40	0.27	(6.9)	
1.93	(49.0)	48	0.26	(6.6)	
1.92	(48.8)	56	0.25	(6.3)	
1.91	(48.5)	64	0.24	(6.1)	
1.90	(48.3)	72	0.23	(5.8)	
1.89	(48.0)	76	0.22	(5.6)	
1.88	(47.8)	80	0.21	(5.3)	
1.87	(47.5)	84	0.20	(5.1)	
1.86	(47.2)	88	0.19	(4.8)	
1.85	(47.0)	92	0.18	(4.6)	
1.84	(46.7)	96	0.17	(4.3)	
1.83	(46.5)	100	0.16	(4.1)	
1.82	(46.2)	104	0.15	(3.8)	
1.81	(46.0)	108	0.14	(3.6)	
1.80	(45.7)	112	0.13	(3.3)	
1.79	(45.5)	116	0.12	(3.0)	
1.78	(45.2)	120	0.11	(2.8)	

### 311, 312, 313, 314 - 6.75 in. (171.5 mm)

**Track Shoes <sup>(1)</sup>  
Triple Grouser**

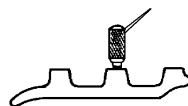
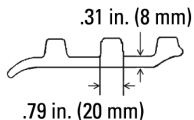
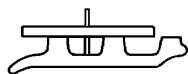

Depth Gauge			Ultrasonic	
Inches	(mm)	% Worn	Inches	(mm)
0.80	(20.5)	0	1.10	(27.9)
0.75	(19.0)	10	1.05	(26.7)
0.70	(18.0)	19	1.00	(25.4)
0.65	(16.5)	28	0.95	(24.1)
0.60	(15.0)	37	0.90	(22.9)
0.55	(14.0)	46	0.85	(21.6)
0.50	(12.5)	55	0.80	(20.3)
0.45	(11.5)	64	0.75	(19.1)
0.40	(10.0)	73	0.70	(17.8)
0.35	(9.0)	82	0.65	(16.5)
0.30	(7.5)	91	0.60	(15.2)
0.25	(6.5)	100	0.55	(14.0)
0.20	(5.0)	109	0.50	(12.7)
0.15	(4.0)	118	0.45	(11.4)
0.10	(2.5)	127	0.40	(10.2)



# 311, 312, 313, 314 — 6.75 in. (171.5 mm)

## Track Shoes <sup>(1)</sup> Self Cleaning



Depth Gauge

Inches	(mm)	% Worn
3.30	(84.0)	0
3.28	(83.5)	6
3.26	(83.0)	12
3.24	(82.5)	18
3.22	(82.0)	24
3.20	(81.5)	30
3.18	(81.0)	36
3.16	(80.5)	42
3.14	(80.0)	48
3.12	(79.0)	54
3.10	(78.5)	60
3.08	(78.0)	64
3.06	(77.5)	68
3.04	(77.0)	72
3.02	(76.5)	76
3.00	(76.0)	80
2.98	(75.5)	84
2.96	(75.0)	88
2.94	(74.5)	92
2.92	(74.0)	96
2.90	(73.5)	100
2.88	(73.0)	104
2.86	(72.5)	108
2.84	(72.0)	112
2.82	(71.5)	116
2.80	(71.0)	120

### 311, 312, 313, 314 — 6.75 in. (171.5 mm)

Idlers <sup>(1)</sup> <sup>(2)</sup> <sup>(3)</sup>

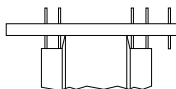

**Depth Gauge**

Inches	(mm)	% Worn
0.70	(18.0)	0
0.72	(18.5)	12
0.74	(19.0)	24
0.76	(19.5)	36
0.78	(20.0)	48
0.80	(20.5)	60
0.82	(21.0)	72
0.84	(21.5)	76
0.86	(22.0)	80
0.88	(22.5)	84
0.90	(23.0)	88
0.92	(23.5)	92
0.94	(24.0)	96
0.96	(24.5)	100
0.98	(25.0)	104
1.00	(25.5)	108
1.02	(26.0)	112
1.04	(26.5)	116
1.06	(27.0)	120

- 1 Flange width is 2.69 in. (68.2 mm)
- 2 New tread diameter is 17.95 in. (456 mm)
- 3 Wear Chart: 4345

Carrier Rollers <sup>(1)</sup>

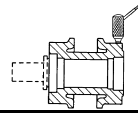
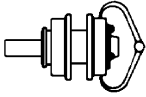

**Caliper**  
All

**Ultrasonic**  
One-piece rim

Inches	(mm)	% Worn	Inches	(mm)
4.41	(112.0)	0	0.98	(24.9)
4.37	(111.0)	6	0.96	(24.4)
4.33	(110.0)	12	0.94	(23.9)
4.29	(109.0)	18	0.92	(23.4)
4.25	(108.0)	24	0.90	(22.9)
4.21	(107.0)	28	0.88	(22.4)
4.17	(106.0)	32	0.86	(21.8)
4.13	(105.0)	36	0.84	(21.3)
4.09	(104.0)	40	0.82	(20.8)
4.05	(103.0)	44	0.80	(20.3)
4.01	(102.0)	48	0.78	(19.8)
3.97	(101.0)	52	0.76	(19.3)
3.93	(100.0)	56	0.74	(18.8)
3.89	(99.0)	60	0.72	(18.3)
3.85	(98.0)	64	0.70	(17.8)
3.81	(97.0)	68	0.68	(17.3)
3.77	(96.0)	72	0.66	(16.8)
3.73	(94.5)	76	0.64	(16.3)
3.69	(93.5)	80	0.62	(15.7)
3.65	(92.5)	84	0.60	(15.2)
3.61	(91.5)	88	0.58	(14.7)
3.57	(90.5)	92	0.56	(14.2)
3.53	(89.5)	96	0.54	(13.7)
3.49	(88.5)	100	0.52	(13.2)
3.45	(87.5)	104	0.50	(12.7)
3.41	(86.5)	108	0.48	(12.2)
3.37	(85.5)	112	0.46	(11.7)
3.33	(84.5)	116	0.44	(11.2)
3.29	(83.5)	120	0.42	(10.7)

**NOTE**

This Carrier Roller is manufactured with cast iron. Using ultrasonic may be less accurate than calipers.

# 311, 312, 313, 314 - 6.75 in. (171.5 mm)

## Track Rollers <sup>(1)</sup> <sup>(2)</sup>

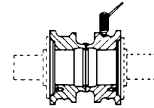
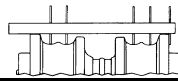
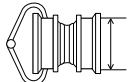

Caliper			Depth Gauge		Ultrasonic	
Inches	(mm)	% Worn	Inches	(mm)	Inches	(mm)
5.43	(138.0)	0	0.59	(15.0)	1.65	(41.9)
5.41	(137.5)	5	0.60	(15.0)	1.64	(41.7)
5.39	(137.0)	10	0.61	(15.5)	1.63	(41.4)
5.37	(136.5)	15	0.62	(15.5)	1.62	(41.1)
5.35	(136.0)	20	0.63	(16.0)	1.61	(40.9)
5.33	(135.5)	25	0.64	(16.5)	1.60	(40.6)
5.31	(135.0)	30	0.65	(16.5)	1.59	(40.4)
5.29	(134.5)	35	0.66	(17.0)	1.58	(40.1)
5.27	(134.0)	40	0.67	(17.0)	1.57	(39.9)
5.25	(133.5)	45	0.68	(17.5)	1.56	(39.6)
5.23	(133.0)	50	0.69	(17.5)	1.55	(39.4)
5.21	(132.5)	55	0.70	(18.0)	1.54	(39.1)
5.19	(132.0)	60	0.71	(18.0)	1.53	(38.9)
5.17	(131.5)	64	0.72	(18.5)	1.52	(38.6)
5.15	(131.0)	67	0.73	(18.5)	1.51	(38.4)
5.13	(130.5)	70	0.74	(19.0)	1.50	(38.1)
5.11	(130.0)	73	0.75	(19.0)	1.49	(37.8)
5.09	(129.5)	76	0.76	(19.5)	1.48	(37.6)
5.07	(129.0)	79	0.77	(19.5)	1.47	(37.3)
5.05	(128.5)	82	0.78	(20.0)	1.46	(37.1)
5.03	(128.0)	85	0.79	(20.0)	1.45	(36.8)
5.01	(127.5)	88	0.80	(20.5)	1.44	(36.6)
4.99	(126.5)	91	0.81	(20.5)	1.43	(36.3)
4.97	(126.0)	94	0.82	(21.0)	1.42	(36.1)
4.95	(125.5)	97	0.83	(21.0)	1.41	(35.8)
4.93	(125.0)	100	0.84	(21.5)	1.40	(35.6)
4.91	(124.5)	103	0.85	(21.5)	1.39	(35.3)
4.89	(124.0)	106	0.86	(22.0)	1.38	(35.1)
4.87	(123.5)	109	0.87	(22.0)	1.37	(34.8)
4.85	(123.0)	112	0.88	(22.5)	1.36	(34.5)
4.83	(122.5)	115	0.89	(22.5)	1.35	(34.3)
4.81	(122.0)	118	0.90	(23.0)	1.34	(34.0)
4.79	(121.5)	121	0.91	(23.0)	1.33	(33.8)

1 Flange diameter is 6.61 in. (168 mm)

2 Wear Chart: 5249



**313D2 LGP, 315, 316, 317, 318, 319, 320, 320 FM, 321, 322, 322 FM, 323, 324, 326, 1090 - 7.50 in. (190 mm)**

**Track Links <sup>(1)</sup>**  
**Genuine, Classic & General Duty**  
**Sealed Track, Grease Lubricated Track**  
**335-9246 & 47 Links**  
**287-3118 & 19 Links**  
**9W-3137 & 38 Links**  
**422-5495 & 96 Links**

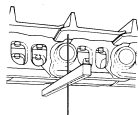

Depth Gauge			Ultrasonic	
Inches	(mm)	% Worn	Inches	(mm)
4.17	(106.0)	0	1.21	(30.7)
4.15	(105.5)	9	1.19	(30.2)
4.13	(105.0)	18	1.17	(29.7)
4.11	(104.5)	27	1.15	(29.2)
4.09	(104.0)	36	1.13	(28.7)
4.07	(103.5)	45	1.11	(28.2)
4.05	(103.0)	54	1.09	(27.7)
4.03	(102.5)	60	1.07	(27.2)
4.01	(102.0)	65	1.05	(26.7)
3.99	(101.5)	70	1.03	(26.2)
3.97	(101.0)	75	1.01	(25.7)
3.95	(100.5)	80	0.99	(25.1)
3.93	(100.0)	85	0.97	(24.6)
3.91	(99.5)	90	0.95	(24.1)
3.89	(99.0)	95	0.93	(23.6)
3.87	(98.5)	100	0.91	(23.1)
3.85	(98.0)	105	0.89	(22.6)
3.83	(97.5)	110	0.87	(22.1)
3.81	(97.0)	115	0.85	(21.6)
3.79	(96.5)	120	0.83	(21.1)

1 Wear Chart: 84

# 320 FM, TK711, 1090 - 7.50 in. (190 mm)

## Track Links <sup>(1)</sup> Heavy Duty 106-1625 & 26

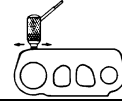
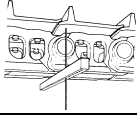

Depth Gauge			Ultrasonic	
Inches	(mm)	% Worn	Inches	(mm)
4.68	(119.0)	0	1.53	(38.9)
4.66	(118.5)	5	1.51	(38.4)
4.64	(118.0)	10	1.49	(37.8)
4.62	(117.5)	15	1.47	(37.3)
4.60	(117.0)	20	1.45	(36.8)
4.58	(116.5)	25	1.43	(36.3)
4.56	(116.0)	30	1.41	(35.8)
4.54	(115.5)	35	1.39	(35.3)
4.52	(115.0)	40	1.37	(34.8)
4.50	(114.5)	45	1.35	(34.3)
4.48	(114.0)	50	1.33	(33.8)
4.46	(113.5)	55	1.31	(33.3)
4.44	(113.0)	60	1.29	(32.8)
4.42	(112.5)	65	1.27	(32.3)
4.40	(112.0)	70	1.25	(31.8)
4.38	(111.5)	75	1.23	(31.2)
4.36	(110.5)	80	1.21	(30.7)
4.34	(110.0)	84	1.19	(30.2)
4.32	(109.5)	88	1.17	(29.7)
4.30	(109.0)	92	1.15	(29.2)
4.28	(108.5)	96	1.13	(28.7)
4.26	(108.0)	100	1.11	(28.2)
4.24	(107.5)	104	1.09	(27.7)
4.22	(107.0)	108	1.07	(27.2)
4.20	(106.5)	112	1.05	(26.7)
4.18	(106.0)	116	1.03	(26.2)
4.16	(105.5)	120	1.01	(25.7)

**Pins and Bushings <sup>(1)</sup>**  
**Internal Wear**  
**Sealed Track**  
**Grease Lubricated Track**  
**Genuine, Classic & General Duty**

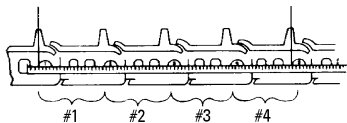

Inches	(mm)	% Worn
29.95	(760.5)	0
30.00	(762.0)	10
30.05	(763.5)	20
30.10	(764.5)	30
30.15	(766.0)	40
30.20	(767.0)	50
30.25	(768.5)	60
30.30	(769.5)	70
30.35	(771.0)	80
30.40	(772.0)	90
30.45	(773.5)	100
30.50	(774.5)	105
30.55	(776.0)	110
30.60	(777.0)	115
30.65	(778.5)	120

1 Wear Chart: 380



**Bushings<sup>(1)</sup>**  
**External Wear**  
**Grease Lubricated Track**  
 Use with 9W, 287-3118 & 19, or 335-9246 & 47 Links

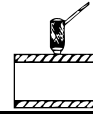

Caliper		Allowable Wear		Ultrasonic	
Inches	(mm)	Lesser % Worn	Greater % Worn	Inches	(mm)
2.39	(60.7)	0	0	0.45	(11.4)
2.38	(60.5)	8	6	0.44	(11.2)
2.37	(60.2)	16	12	0.43	(10.9)
2.36	(59.9)	24	18	0.42	(10.7)
2.35	(59.7)	32	24	0.41	(10.4)
2.34	(59.4)	40	30	0.40	(10.2)
2.33	(59.2)	48	36	0.39	(9.9)
2.32	(58.9)	56	42	0.38	(9.7)
2.31	(58.7)	64	48	0.37	(9.4)
2.30	(58.4)	68	54	0.36	(9.1)
2.29	(58.2)	72	58	0.35	(8.9)
2.28	(57.9)	76	61	0.34	(8.6)
2.27	(57.7)	80	64	0.33	(8.4)
2.26	(57.4)	84	67	0.32	(8.1)
2.25	(57.2)	88	70	0.31	(7.9)
2.24	(56.9)	92	73	0.30	(7.6)
2.23	(56.6)	96	76	0.29	(7.4)
2.22	(56.4)	100	79	0.28	(7.1)
2.21	(56.1)	104	82	0.27	(6.9)
2.20	(55.9)	108	85	0.26	(6.6)
2.19	(55.6)	112	88	0.25	(6.4)
2.18	(55.4)	116	91	0.24	(6.1)
2.17	(55.1)	120	94	0.23	(5.8)
2.16	(54.9)		97	0.22	(5.6)
2.15	(54.6)		100	0.21	(5.3)
2.14	(54.4)		103	0.20	(5.1)
2.13	(54.1)		106	0.19	(4.8)
2.12	(53.8)		109	0.18	(4.6)
2.11	(53.6)		112	0.17	(4.3)
2.10	(53.3)		115	0.16	(4.1)
2.09	(53.1)		118	0.15	(3.8)
2.08	(52.8)		121	0.14	(3.6)

# 320 FM, TK711, 1090 - 7.50 in. (190 mm)

## Bushings <sup>(1)</sup> External Wear Heavy Duty Use with 106-1625 & 26 Links

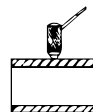
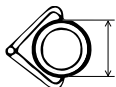

Allowable Wear					
Caliper		Lesser	Greater	Ultrasonic	
Inches	(mm)	% Worn	% Worn	Inches	(mm)
2.56	(65.0)	0	0	0.51	(13.0)
2.54	(64.5)	10	8	0.49	(12.4)
2.52	(64.0)	20	16	0.47	(11.9)
2.50	(63.5)	30	24	0.45	(11.4)
2.48	(63.0)	40	32	0.43	(10.9)
2.46	(62.5)	50	40	0.41	(10.4)
2.44	(62.0)	60	48	0.39	(9.9)
2.42	(61.5)	70	52	0.37	(9.4)
2.40	(61.0)	76	56	0.35	(8.9)
2.38	(60.5)	80	60	0.33	(8.4)
2.36	(59.9)	84	64	0.31	(7.9)
2.34	(59.4)	88	68	0.29	(7.4)
2.32	(58.9)	92	72	0.27	(6.9)
2.30	(58.4)	96	76	0.25	(6.3)
2.28	(57.9)	100	80	0.23	(5.8)
2.26	(57.4)	104	84	0.21	(5.3)
2.24	(56.9)	108	88	0.19	(4.8)
2.22	(56.4)	112	92	0.17	(4.3)
2.20	(55.9)	116	96	0.15	(3.8)
2.18	(55.4)	120	100	0.13	(3.3)
2.16	(54.9)		104	0.11	(2.8)
2.14	(54.4)		108	0.09	(2.3)
2.12	(53.8)		112	0.07	(1.8)
2.10	(53.3)		116	0.05	(1.3)
2.08	(52.8)		120	0.03	(0.8)

**Bushings - Classic & General Duty <sup>(1)</sup>**  
**External Wear**  
**Grease Lubricated Track**  
**Use with 287-3118 & 19 or 422-5495 & 96 Links**

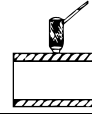
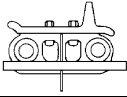

Depth Gauge		Allowable Wear		Ultrasonic	
Inches	(mm)	Lesser % Worn	Greater % Worn	Inches	(mm)
2.31	(58.7)	0	0	0.42	(10.7)
2.30	(58.4)	8	6	0.41	(10.4)
2.29	(58.2)	16	12	0.40	(10.2)
2.28	(57.9)	24	18	0.39	(9.9)
2.27	(57.7)	32	24	0.38	(9.7)
2.26	(57.4)	40	30	0.37	(9.4)
2.25	(57.2)	48	36	0.36	(9.1)
2.24	(56.9)	56	42	0.35	(8.9)
2.23	(56.6)	64	48	0.34	(8.6)
2.22	(56.4)	72	54	0.33	(8.4)
2.21	(56.1)	80	60	0.32	(8.1)
2.20	(55.9)	88	66	0.31	(7.9)
2.19	(55.6)	94	72	0.30	(7.6)
2.18	(55.4)	97	76	0.29	(7.4)
2.17	(55.1)	100	79	0.28	(7.1)
2.16	(54.9)	103	82	0.27	(6.9)
2.15	(54.6)	106	85	0.26	(6.6)
2.14	(54.4)	109	88	0.25	(6.4)
2.13	(54.1)	112	91	0.24	(6.1)
2.12	(53.8)	115	94	0.23	(5.8)
2.11	(53.6)	118	97	0.22	(5.6)
2.10	(53.3)	121	100	0.21	(5.3)
2.09	(53.1)	124	103	0.20	(5.1)
2.08	(52.8)	127	106	0.19	(4.8)
2.07	(52.6)	130	109	0.18	(4.6)
2.06	(52.3)	133	112	0.17	(4.3)
2.05	(52.1)	136	115	0.16	(4.1)
2.04	(51.8)	139	118	0.15	(3.8)
2.03	(51.6)	142	121	0.14	(3.6)

**315, 316, 317, 318, 320, 320 FM, 322, 322 FM - 7.50 in. (190 mm)**

**Bushings <sup>(1)</sup>  
External Wear  
Sealed Track**

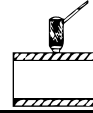

Caliper			Ultrasonic		
Inches	(mm)	% Worn	Inches	(mm)	
2.33	(59.2)	0	0	(10.7)	
2.32	(58.9)	10	6	(10.4)	
2.31	(58.7)	20	12	(10.2)	
2.30	(58.4)	30	18	(9.9)	
2.29	(58.2)	40	24	(9.7)	
2.28	(57.9)	50	30	(9.4)	
2.27	(57.7)	60	36	(9.1)	
2.26	(57.4)	70	42	(8.9)	
2.25	(57.2)	75	48	(8.6)	
2.24	(56.9)	80	54	(8.4)	
2.23	(56.6)	85	60	(8.1)	
2.22	(56.4)	90	66	(7.9)	
2.21	(56.1)	95	72	(7.6)	
2.20	(55.9)	100	78	(7.4)	
2.19	(55.6)	105	82	(7.1)	
2.18	(55.4)	110	85	(6.9)	
2.17	(55.1)	115	88	(6.6)	
2.16	(54.9)	120	91	(6.4)	
2.15	(54.6)		94	(6.1)	
2.14	(54.4)		97	(5.8)	
2.13	(54.1)		100	(5.6)	
2.12	(53.8)		103	(5.3)	
2.11	(53.6)		106	(5.1)	
2.10	(53.3)		109	(4.8)	
2.09	(53.1)		112	(4.6)	
2.08	(52.8)		115	(4.3)	
2.07	(52.6)		118	(4.1)	
2.06	(52.3)		121	(3.8)	

**Track Shoes <sup>(1)</sup>  
Extreme Service**

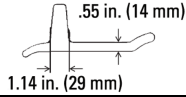
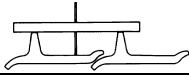

**Depth Gauge**

**Ultrasonic**

Inches	(mm)	% Worn	Inches	(mm)
2.55	(65.0)	0	3.15	(80.0)
2.45	(62.0)	6	3.05	(77.5)
2.35	(59.5)	12	2.95	(74.9)
2.25	(57.0)	18	2.85	(72.4)
2.15	(54.5)	24	2.75	(69.9)
2.05	(52.0)	30	2.65	(67.3)
1.95	(49.5)	36	2.55	(64.8)
1.85	(47.0)	42	2.45	(62.2)
1.75	(44.5)	48	2.35	(59.7)
1.65	(42.0)	54	2.25	(57.2)
1.55	(39.5)	60	2.15	(54.6)
1.45	(37.0)	66	2.05	(52.1)
1.35	(34.5)	72	1.95	(49.5)
1.25	(32.0)	78	1.85	(47.0)
1.15	(29.0)	84	1.75	(44.5)
1.05	(26.5)	90	1.65	(41.9)
0.95	(24.0)	95	1.55	(39.4)
0.85	(21.5)	100	1.45	(36.8)
0.75	(19.0)	105	1.35	(34.3)
0.65	(16.5)	110	1.25	(31.8)
0.55	(14.0)	115	1.15	(29.2)
0.45	(11.5)	120	1.05	(26.7)

# 313D2 LGP - 7.50 in. (190 mm)

## Track Shoes <sup>(1)</sup> Moderate Service

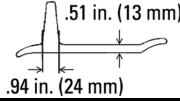
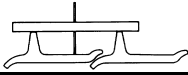

Depth Gauge			Ultrasonic	
Inches	(mm)	% Worn	Inches	(mm)
2.25	(57.0)	0	2.75	(69.9)
2.20	(56.0)	4	2.70	(68.6)
2.15	(54.5)	8	2.65	(67.3)
2.10	(53.5)	12	2.60	(66.0)
2.05	(52.0)	16	2.55	(64.8)
2.00	(51.0)	20	2.50	(63.5)
1.95	(49.5)	24	2.45	(62.2)
1.90	(48.5)	28	2.40	(61.0)
1.85	(47.0)	32	2.35	(59.7)
1.80	(45.5)	36	2.30	(58.4)
1.75	(44.5)	40	2.25	(57.2)
1.70	(43.0)	44	2.20	(55.9)
1.65	(42.0)	48	2.15	(54.6)
1.60	(40.5)	52	2.10	(53.3)
1.55	(39.5)	56	2.05	(52.1)
1.50	(38.0)	60	2.00	(50.8)
1.45	(37.0)	64	1.95	(49.5)
1.40	(35.5)	67	1.90	(48.3)
1.35	(34.5)	70	1.85	(47.0)
1.30	(33.0)	73	1.80	(45.7)
1.25	(32.0)	76	1.75	(44.5)
1.20	(30.5)	79	1.70	(43.2)
1.15	(29.0)	82	1.65	(41.9)
1.10	(28.0)	85	1.60	(40.6)
1.05	(26.5)	88	1.55	(39.4)
1.00	(25.5)	91	1.50	(38.1)
0.95	(24.0)	94	1.45	(36.8)
0.90	(23.0)	97	1.40	(35.6)
0.85	(21.5)	100	1.35	(34.3)
0.80	(20.5)	103	1.30	(33.0)
0.75	(19.0)	106	1.25	(31.8)
0.70	(18.0)	109	1.20	(30.5)
0.65	(16.5)	112	1.15	(29.2)
0.60	(15.0)	115	1.10	(27.9)
0.55	(14.0)	118	1.05	(26.7)
0.50	(12.5)	121	1.00	(25.4)

**Track Shoes <sup>(1)</sup>  
Moderate Service**

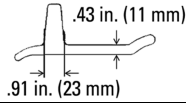
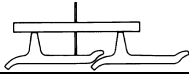

**Depth Gauge**

**Ultrasonic**

Depth Gauge		% Worn	Ultrasonic	
Inches	(mm)		Inches	(mm)
1.85	(47.0)	0	2.30	(58.4)
1.80	(45.5)	5	2.25	(57.2)
1.75	(44.5)	10	2.20	(55.9)
1.70	(43.0)	15	2.15	(54.6)
1.65	(42.0)	20	2.10	(53.3)
1.60	(40.5)	25	2.05	(52.1)
1.55	(39.5)	30	2.00	(50.8)
1.50	(38.0)	35	1.95	(49.5)
1.45	(37.0)	40	1.90	(48.3)
1.40	(35.5)	45	1.85	(47.0)
1.35	(34.5)	50	1.80	(45.7)
1.30	(33.0)	55	1.75	(44.5)
1.25	(32.0)	60	1.70	(43.2)
1.20	(30.5)	64	1.65	(41.9)
1.15	(29.0)	68	1.60	(40.6)
1.10	(28.0)	72	1.55	(39.4)
1.05	(26.5)	76	1.50	(38.1)
1.00	(25.5)	80	1.45	(36.8)
0.95	(24.0)	84	1.40	(35.6)
0.90	(23.0)	88	1.35	(34.3)
0.85	(21.5)	92	1.30	(33.0)
0.80	(20.5)	96	1.25	(31.8)
0.75	(19.0)	100	1.20	(30.5)
0.70	(18.0)	104	1.15	(29.2)
0.65	(16.5)	108	1.10	(27.9)
0.60	(15.0)	112	1.05	(26.7)
0.55	(14.0)	116	1.00	(25.4)
0.50	(12.5)	120	0.95	(24.1)

**Track Shoes <sup>(1)</sup>  
Double Grouser**

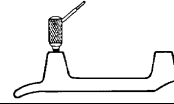
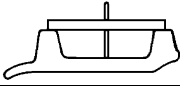
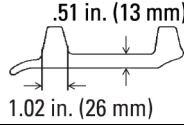

**Depth Gauge**

**Ultrasonic**

Depth Gauge		% Worn	Ultrasonic	
Inches	(mm)		Inches	(mm)
1.40	(35.5)	0	1.89	(48.0)
1.35	(34.5)	8	1.84	(46.7)
1.30	(33.0)	16	1.79	(45.5)
1.25	(32.0)	24	1.74	(44.2)
1.20	(30.5)	32	1.69	(42.9)
1.15	(29.0)	40	1.64	(41.7)
1.10	(28.0)	48	1.59	(40.4)
1.05	(26.5)	56	1.54	(39.1)
1.00	(25.5)	64	1.49	(37.8)
0.95	(24.0)	72	1.44	(36.6)
0.90	(23.0)	79	1.39	(35.3)
0.85	(21.5)	86	1.34	(34.0)
0.80	(20.5)	93	1.29	(32.8)
0.75	(19.0)	100	1.24	(31.5)
0.70	(18.0)	107	1.19	(30.2)
0.65	(16.5)	114	1.14	(29.0)
0.60	(15.0)	121	1.09	(27.7)



**Track Shoes <sup>(1)</sup>  
Heavy Duty Triple Grouser**

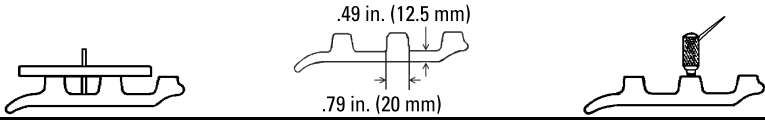

Depth Gauge			Ultrasonic	
Inches	(mm)	% Worn	Inches	(mm)
1.10	(28.0)	0	1.60	(40.6)
1.05	(26.5)	6	1.55	(39.4)
1.00	(25.5)	12	1.50	(38.1)
0.95	(24.0)	18	1.45	(36.8)
0.90	(23.0)	24	1.40	(35.6)
0.85	(21.5)	30	1.35	(34.3)
0.80	(20.5)	36	1.30	(33.0)
0.75	(19.0)	42	1.25	(31.8)
0.70	(18.0)	48	1.20	(30.5)
0.65	(16.5)	54	1.15	(29.2)
0.60	(15.0)	60	1.10	(27.9)
0.55	(14.0)	66	1.05	(26.7)
0.50	(12.5)	72	1.00	(25.4)
0.45	(11.5)	78	0.95	(24.1)
0.40	(10.0)	84	0.90	(22.9)
0.35	(9.0)	90	0.85	(21.6)
0.30	(7.5)	95	0.80	(20.3)
0.25	(6.5)	100	0.75	(19.1)
0.20	(5.0)	105	0.70	(17.8)
0.15	(4.0)	110	0.65	(16.5)
0.10	(2.5)	115	0.60	(15.2)
0.05	(1.5)	120	0.55	(14.0)

313D2 LGP, 315, 316, 317, 318, 319, 320, 320 FM, 321, 322, 322 FM, 323, 324, 326, TK711 - 7.50 in. (190 mm)

**Track Shoes <sup>(1)</sup>  
Triple Grouser  
Genuine and Classic**

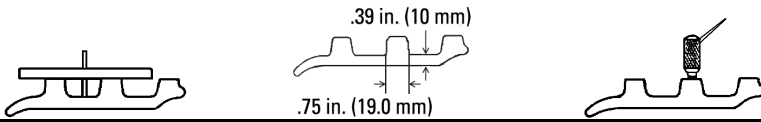

Depth Gauge			Ultrasonic	
Inches	(mm)	% Worn	Inches	(mm)
1.00	(25.5)	0	1.42	(36.0)
0.95	(24.0)	7	1.37	(34.7)
0.90	(23.0)	14	1.32	(33.5)
0.85	(21.5)	21	1.27	(32.2)
0.80	(20.5)	28	1.22	(30.9)
0.75	(19.0)	35	1.17	(29.7)
0.70	(18.0)	42	1.12	(28.4)
0.65	(16.5)	49	1.07	(27.1)
0.60	(15.0)	56	1.02	(25.8)
0.55	(14.0)	63	0.97	(24.6)
0.50	(12.5)	70	0.92	(23.3)
0.45	(11.5)	76	0.87	(22.0)
0.40	(10.0)	82	0.82	(20.8)
0.35	(9.0)	88	0.77	(19.5)
0.30	(7.5)	94	0.72	(18.2)
0.25	(6.5)	100	0.67	(17.0)
0.20	(5.0)	106	0.62	(15.7)
0.15	(4.0)	112	0.57	(14.4)
0.10	(2.5)	118	0.52	(13.1)
0.5	(1.5)	124	0.47	(11.9)

**Track Shoes<sup>(1)</sup>  
Triple Grouser  
Genuine, Classic & General Duty**

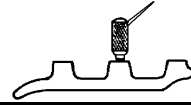
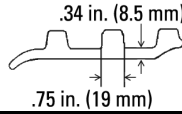
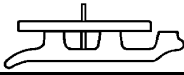

Depth Gauge		Low Impact	Ultrasonic	
Inches	(mm)	% Worn	Inches	(mm)
1.00	(25.5)	0	1.36	(34.5)
0.95	(24.0)	7	1.31	(33.2)
0.90	(23.0)	14	1.26	(32.0)
0.85	(21.5)	21	1.21	(30.7)
0.80	(20.5)	28	1.16	(29.4)
0.75	(19.0)	35	1.11	(28.2)
0.70	(18.0)	42	1.06	(26.9)
0.65	(16.5)	49	1.01	(25.6)
0.60	(15.0)	56	0.96	(24.3)
0.55	(14.0)	63	0.91	(23.1)
0.50	(12.5)	70	0.86	(21.8)
0.45	(11.5)	76	0.81	(20.5)
0.40	(10.0)	82	0.76	(19.3)
0.35	(9.0)	88	0.71	(18.0)
0.30	(7.5)	94	0.66	(16.7)
0.25	(6.5)	100	0.61	(15.5)
0.20	(5.0)	106	0.56	(14.2)
0.15	(4.0)	112	0.51	(12.9)
0.10	(2.5)	118	0.46	(11.6)
0.05	(1.5)	124	0.41	(10.4)

**Idlers <sup>(1)</sup> <sup>(2)</sup> <sup>(3)</sup>**  
**Not for use on TK711**

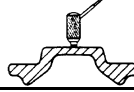
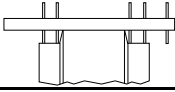

Depth Gauge		
Inches	(mm)	% Worn
0.74	(19.0)	0
0.76	(19.5)	12
0.78	(20.0)	24
0.80	(20.5)	36
0.82	(21.0)	48
0.84	(21.5)	60
0.86	(22.0)	72
0.88	(22.5)	76
0.90	(23.0)	80
0.92	(23.5)	84
0.94	(24.0)	88
0.96	(24.5)	92
0.98	(25.0)	96
1.00	(25.5)	100
1.02	(26.0)	104
1.04	(26.5)	108
1.06	(27.0)	112
1.08	(27.5)	116
1.10	(28.0)	120

Ultrasonic		Center Flange Wear	
Inches	(mm)	Inches	(mm)
0.40	(10.2)	0.00	(0.0)
0.38	(9.7)	0.02	(0.5)
0.36	(9.1)	0.04	(1.0)
0.34	(8.6)	0.06	(1.5)
0.32	(8.1)	0.08	(2.0)
0.30	(7.6)	0.10	(2.5)
0.28	(7.1)	0.12	(3.0)
0.26	(6.6)	0.14	(3.5)
0.24	(6.1)	0.16	(4.0)
0.22	(5.6)	0.18	(4.5)
0.20	(5.1)	0.20	(5.0)
0.18	(4.6)	0.22	(5.5)
0.16	(4.1)	0.24	(6.0)
0.14	(3.6)	0.26	(6.5)
0.12	(3.0)	0.28	(7.0)
0.10	(2.5)	0.30	(7.5)
0.08	(2.0)	0.32	(8.0)
0.06	(1.5)	0.34	(8.5)
0.04	(1.0)	0.36	(9.0)

**NOTE**

Ultrasonic measurement is to determine flange wear only. Use the ultrasonic only on fabricated idlers.

- 1 Flange width is 3.31 in. (84 mm)
- 2 New tread diameter is 19.73 in. (507 mm)
- 3 Wear Chart: 4384

Idlers <sup>(1)</sup> <sup>(2)</sup> <sup>(3)</sup>  
 Only for use on TK711

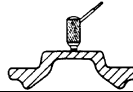
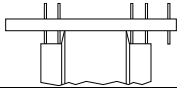

Depth Gauge		
Inches	(mm)	% Worn
0.78	(20.0)	0
0.80	(20.5)	12
0.82	(21.0)	24
0.84	(21.5)	36
0.86	(22.0)	44
0.88	(22.5)	48
0.90	(23.0)	52
0.92	(23.5)	56
0.94	(24.0)	60
0.96	(24.5)	64
0.98	(25.0)	68
1.00	(25.5)	72
1.02	(26.0)	76
1.04	(26.5)	80
1.06	(27.0)	84
1.08	(27.5)	88
1.10	(28.0)	92
1.12	(28.5)	96
1.14	(29.0)	100
1.16	(29.5)	104
1.18	(30.0)	108
1.20	(30.5)	112
1.22	(31.0)	116
1.24	(31.5)	120

Ultrasonic		Center Flange Wear	
Inches	(mm)	Inches	(mm)
0.48	(12.2)	0.00	(0.0)
0.46	(11.7)	0.02	(0.5)
0.44	(11.2)	0.04	(1.0)
0.42	(10.7)	0.06	(1.5)
0.40	(10.2)	0.08	(2.0)
0.38	(9.7)	0.10	(2.5)
0.36	(9.1)	0.12	(3.0)
0.34	(8.6)	0.14	(3.5)
0.32	(8.1)	0.16	(4.0)
0.30	(7.6)	0.18	(4.5)
0.28	(7.1)	0.20	(5.0)
0.26	(6.6)	0.22	(5.5)
0.24	(6.1)	0.24	(6.0)
0.22	(5.6)	0.26	(6.5)
0.20	(5.1)	0.28	(7.0)
0.18	(4.6)	0.30	(7.5)
0.16	(4.1)	0.32	(8.0)
0.14	(3.6)	0.34	(8.5)
0.12	(3.0)	0.36	(9.0)
0.10	(2.5)	0.38	(9.5)
0.08	(2.0)	0.40	(10.0)
0.06	(1.5)	0.42	(10.5)
0.04	(1.0)	0.44	(11.0)
0.02	(0.5)	0.46	(11.5)

**NOTE**

Ultrasonic measurement is to determine flange wear only. Use the ultrasonic only on fabricated idlers.

- 1 Flange width is 3.75 in. (95 mm)
- 2 New tread diameter is 21.26 in. (540 mm)
- 3 Wear Chart: 4405

**Idlers <sup>(1)</sup> <sup>(2)</sup> <sup>(3)</sup>**  
**Classic & General Duty**

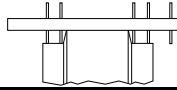

**Depth Gauge**

Inches	(mm)	% Worn
0.78	(20.0)	0
0.80	(20.5)	12
0.82	(21.0)	24
0.84	(21.5)	36
0.86	(22.0)	44
0.88	(22.5)	48
0.90	(23.0)	52
0.92	(23.5)	56
0.94	(24.0)	60
0.96	(24.5)	64
0.98	(25.0)	68
1.00	(25.5)	72
1.02	(26.0)	76
1.04	(26.5)	80
1.06	(27.0)	84
1.08	(27.5)	88
1.10	(28.0)	92
1.12	(28.5)	96
1.14	(29.0)	100
1.16	(29.5)	104
1.18	(30.0)	108
1.20	(30.5)	112
1.22	(31.0)	116
1.24	(31.5)	120

- 1 Flange width is 3.31 in. (84 mm)
- 2 New tread diameter is 19.88 in. (505 mm)
- 3 Wear Chart: 4386

Carrier Rollers <sup>(1)</sup>

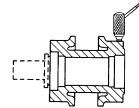
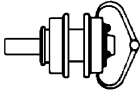

**Caliper**  
All

**Ultrasonic**  
One-piece rim

Inches	(mm)	% Worn	Inches	(mm)
4.72	(120.0)	0	0.93	(23.6)
4.68	(119.0)	6	0.91	(23.1)
4.64	(118.0)	12	0.89	(22.6)
4.60	(117.0)	18	0.87	(22.1)
4.56	(116.0)	24	0.85	(21.6)
4.52	(115.0)	30	0.83	(21.1)
4.48	(114.0)	36	0.81	(20.6)
4.44	(113.0)	42	0.79	(20.1)
4.40	(112.0)	48	0.77	(19.6)
4.36	(110.5)	54	0.75	(19.1)
4.32	(109.5)	60	0.73	(18.5)
4.28	(108.5)	66	0.71	(18.0)
4.24	(107.5)	72	0.69	(17.5)
4.20	(106.5)	76	0.67	(17.0)
4.16	(105.5)	80	0.65	(16.5)
4.12	(104.5)	84	0.63	(16.0)
4.08	(103.5)	88	0.61	(15.5)
4.04	(102.5)	92	0.59	(15.0)
4.00	(101.5)	96	0.57	(14.5)
3.96	(100.5)	100	0.55	(14.0)
3.92	(99.5)	104	0.53	(13.5)
3.88	(98.5)	108	0.51	(13.0)
3.84	(97.5)	112	0.49	(12.4)
3.80	(96.5)	116	0.47	(11.9)
3.76	(95.5)	120	0.45	(11.4)

**NOTE**

For 313D2 LGP, 320C FM, 320D FM, 322C FM, use Track Roller wear chart for Carrier Rollers.

# TK711 - 7.50 in. (190 mm)

## Carrier Rollers <sup>(1)</sup> Only for use on TK711

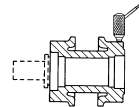
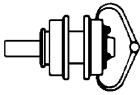

**Caliper  
All**

**Ultrasonic  
One-piece rim**

Caliper		% Worn	Ultrasonic	
Inches	(mm)		Inches	(mm)
6.30	(160.0)	0	1.00	(25.4)
6.26	(159.0)	6	0.98	(24.9)
6.22	(158.0)	12	0.96	(24.4)
6.18	(157.0)	18	0.94	(23.9)
6.14	(156.0)	24	0.92	(23.4)
6.10	(155.0)	30	0.90	(22.9)
6.06	(154.0)	36	0.88	(22.4)
6.02	(153.0)	40	0.86	(21.8)
5.98	(152.0)	44	0.84	(21.3)
5.94	(151.0)	48	0.82	(20.8)
5.90	(150.0)	52	0.80	(20.3)
5.86	(149.0)	56	0.78	(19.8)
5.82	(148.0)	60	0.76	(19.3)
5.78	(147.0)	64	0.74	(18.8)
5.74	(146.0)	68	0.72	(18.3)
5.70	(145.0)	72	0.70	(17.8)
5.66	(144.0)	76	0.68	(17.3)
5.62	(142.5)	80	0.66	(16.8)
5.58	(141.5)	84	0.64	(16.3)
5.54	(140.5)	88	0.62	(15.7)
5.50	(139.5)	92	0.60	(15.2)
5.46	(138.5)	96	0.58	(14.7)
5.42	(137.5)	100	0.56	(14.2)
5.38	(136.5)	104	0.54	(13.7)
5.34	(135.5)	108	0.52	(13.2)
5.30	(134.5)	112	0.50	(12.7)
5.26	(133.5)	116	0.48	(12.2)
5.22	(132.5)	120	0.46	(11.7)



**Carrier Rollers<sup>(1)</sup>  
Classic & General Duty**

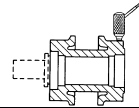
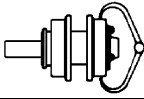

**Caliper  
All**

**Ultrasonic  
One-piece rim**

Inches	(mm)	% Worn	Inches	(mm)
4.72	(120.0)	0	1.33	(33.8)
4.68	(119.0)	6	1.31	(33.3)
4.64	(118.0)	12	1.29	(32.8)
4.60	(117.0)	18	1.27	(32.3)
4.56	(116.0)	24	1.25	(31.8)
4.52	(115.0)	30	1.23	(31.2)
4.48	(114.0)	36	1.21	(30.7)
4.44	(113.0)	42	1.19	(30.2)
4.40	(112.0)	48	1.17	(29.7)
4.36	(110.5)	54	1.15	(29.2)
4.32	(109.5)	60	1.13	(28.7)
4.28	(108.5)	66	1.11	(28.2)
4.24	(107.5)	72	1.09	(27.7)
4.20	(106.5)	78	1.07	(27.2)
4.16	(105.5)	84	1.05	(26.7)
4.12	(104.5)	88	1.03	(26.2)
4.08	(103.5)	91	1.01	(25.7)
4.04	(102.5)	94	0.99	(25.1)
4.00	(101.5)	97	0.97	(24.6)
3.96	(100.5)	100	0.95	(24.1)
3.92	(99.5)	103	0.93	(23.6)
3.88	(98.5)	106	0.91	(23.1)
3.84	(97.5)	109	0.89	(22.6)
3.80	(96.5)	112	0.87	(22.1)
3.76	(95.5)	115	0.85	(21.6)
3.72	(94.5)	118	0.83	(21.1)
3.68	(93.5)	121	0.81	(20.6)

# 313D2 LGP, 315, 316, 317, 318, 319, 320, 320 FM, 321, 323 - 7.50 in. (190 mm)

**Track Rollers <sup>(1) (2)</sup>**  
**Not for use on 322, 324, or TK711**  
**Genuine, Classic & General Duty**

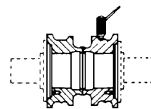
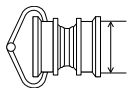

Caliper			Depth Gauge		Ultrasonic	
Inches	(mm)	% Worn	Inches	(mm)	Inches	(mm)
5.90	(150.0)	0	0.69	(17.5)	1.69	(42.9)
5.86	(149.0)	7	0.71	(18.0)	1.67	(42.4)
5.82	(148.0)	14	0.73	(18.5)	1.65	(41.9)
5.78	(147.0)	21	0.75	(19.0)	1.63	(41.4)
5.74	(146.0)	28	0.77	(19.5)	1.61	(40.9)
5.70	(145.0)	35	0.79	(20.0)	1.59	(40.4)
5.66	(144.0)	42	0.81	(20.5)	1.57	(39.9)
5.62	(142.5)	49	0.83	(21.0)	1.55	(39.4)
5.58	(141.5)	56	0.85	(21.5)	1.53	(38.9)
5.54	(140.5)	63	0.87	(22.0)	1.51	(38.4)
5.50	(139.5)	70	0.89	(22.5)	1.49	(37.8)
5.46	(138.5)	76	0.91	(23.0)	1.47	(37.3)
5.42	(137.5)	80	0.93	(23.5)	1.45	(36.8)
5.38	(136.5)	84	0.95	(24.0)	1.43	(36.3)
5.34	(135.5)	88	0.97	(24.5)	1.41	(35.8)
5.30	(134.5)	92	0.99	(25.0)	1.39	(35.3)
5.26	(133.5)	96	1.01	(25.5)	1.37	(34.8)
5.22	(132.5)	100	1.03	(26.0)	1.35	(34.3)
5.18	(131.5)	104	1.05	(26.5)	1.33	(33.8)
5.14	(130.5)	108	1.07	(27.0)	1.31	(33.3)
5.10	(129.5)	112	1.09	(27.5)	1.29	(32.8)
5.06	(128.5)	116	1.11	(28.0)	1.27	(32.3)
5.02	(127.5)	120	1.13	(28.5)	1.25	(31.8)

**NOTE**

Do not measure Classic roller with Ultrasonic tool.

1 Flange diameter is 7.28 in. (185 mm)  
 2 Wear Chart: 5285

## 322, 322 FM, 324, 326, TK711, 1090 - 7.50 in. (190 mm)

### Track Rollers <sup>(1) (2)</sup> Only for use on 322, 324, 326, TK711 & 1090

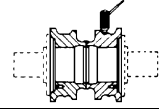

Caliper		% Worn	Depth Gauge		Ultrasonic	
Inches	(mm)		Inches	(mm)	Inches	(mm)
6.30	(160.0)	0	0.69	(17.5)	1.73	(43.9)
6.26	(159.0)	8	0.71	(18.0)	1.71	(43.4)
6.22	(158.0)	16	0.73	(18.5)	1.69	(42.9)
6.18	(157.0)	24	0.75	(19.0)	1.67	(42.4)
6.14	(156.0)	32	0.77	(19.5)	1.65	(41.9)
6.10	(155.0)	40	0.79	(20.0)	1.63	(41.4)
6.06	(154.0)	48	0.81	(20.5)	1.61	(40.9)
6.02	(153.0)	56	0.83	(21.0)	1.59	(40.4)
5.98	(152.0)	64	0.85	(21.5)	1.57	(39.9)
5.94	(151.0)	68	0.87	(22.0)	1.55	(39.4)
5.90	(150.0)	72	0.89	(22.5)	1.53	(38.9)
5.86	(149.0)	76	0.91	(23.0)	1.51	(38.4)
5.82	(148.0)	80	0.93	(23.5)	1.49	(37.8)
5.78	(147.0)	84	0.95	(24.0)	1.47	(37.3)
5.74	(146.0)	88	0.97	(24.5)	1.45	(36.8)
5.70	(145.0)	92	0.99	(25.0)	1.43	(36.3)
5.66	(144.0)	96	1.01	(25.5)	1.41	(35.8)
5.62	(142.5)	100	1.03	(26.0)	1.39	(35.3)
5.58	(141.5)	104	1.05	(26.5)	1.37	(34.8)
5.54	(140.5)	108	1.07	(27.0)	1.35	(34.3)
5.50	(139.5)	112	1.09	(27.5)	1.33	(33.8)
5.46	(138.5)	116	1.11	(28.0)	1.31	(33.3)
5.42	(137.5)	120	1.13	(28.5)	1.29	(32.8)

- 1 Flange diameter is 7.68 in. (195 mm)  
2 Wear Chart: 5310

**320S, 320 FM, 322 FM, 323S, 324 FM, 325, 329, 511, TK711, 1090 - 8.00 in. (203.2 mm)**

**Track Links <sup>(1)</sup>  
 Sealed Track, Grease Lubricated Track  
 Genuine and General Duty  
 6Y-1607 & 08  
 261-1011 & 12  
 461-3805 & 06  
 Not for use on 325 FM**

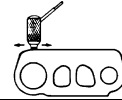
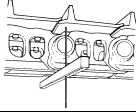

Depth Gauge			Ultrasonic	
Inches	(mm)	% Worn	Inches	(mm)
4.52	(115.0)	0	1.26	(32.0)
4.50	(114.5)	8	1.24	(31.5)
4.48	(114.0)	16	1.22	(31.0)
4.46	(113.5)	24	1.20	(30.5)
4.44	(113.0)	32	1.18	(30.0)
4.42	(112.5)	40	1.16	(29.5)
4.40	(112.0)	45	1.14	(29.0)
4.38	(111.5)	50	1.12	(28.4)
4.36	(110.5)	55	1.10	(27.9)
4.34	(110.0)	60	1.08	(27.4)
4.32	(109.5)	65	1.06	(26.9)
4.30	(109.0)	70	1.04	(26.4)
4.28	(108.5)	75	1.02	(25.9)
4.26	(108.0)	80	1.00	(25.4)
4.24	(107.5)	85	0.98	(24.9)
4.22	(107.0)	90	0.96	(24.4)
4.20	(106.5)	95	0.94	(23.9)
4.18	(106.0)	100	0.92	(23.4)
4.16	(105.5)	105	0.90	(22.9)
4.14	(105.0)	110	0.88	(22.4)
4.12	(104.5)	115	0.86	(21.8)
4.10	(104.0)	120	0.84	(21.3)

**324 FM, 325 FM, 521, 522, 1190, 1390, TK721, TK722, TK741 - 8.00 in. (203.2 mm)**

**Track Links <sup>(1)</sup>  
Heavy Duty Track  
8E-7405 & 06  
365-8401 & 02  
431-2180 & 81**

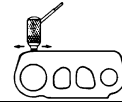
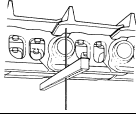

Depth Gauge			Ultrasonic	
Inches	(mm)	% Worn	Inches	(mm)
5.19	(132.0)	0	1.69	(42.9)
5.17	(131.5)	4	1.67	(42.4)
5.15	(131.0)	8	1.65	(41.9)
5.13	(130.5)	12	1.63	(41.4)
5.11	(130.0)	16	1.61	(40.9)
5.09	(129.5)	20	1.59	(40.4)
5.07	(129.0)	24	1.57	(39.9)
5.05	(128.5)	28	1.55	(39.4)
5.03	(128.0)	32	1.53	(38.9)
5.01	(127.5)	36	1.51	(38.4)
4.99	(126.5)	40	1.49	(37.8)
4.97	(126.0)	44	1.47	(37.3)
4.95	(125.5)	48	1.45	(36.8)
4.93	(125.0)	52	1.43	(36.3)
4.91	(124.5)	56	1.41	(35.8)
4.89	(124.0)	60	1.39	(35.3)
4.87	(123.5)	64	1.37	(34.8)
4.85	(123.0)	68	1.35	(34.3)
4.83	(122.5)	72	1.33	(33.8)
4.81	(122.0)	76	1.31	(33.3)
4.79	(121.5)	80	1.29	(32.8)
4.77	(121.0)	84	1.27	(32.3)
4.75	(120.5)	88	1.25	(31.8)
4.73	(120.0)	91	1.23	(31.2)
4.71	(119.5)	94	1.21	(30.7)
4.69	(119.0)	97	1.19	(30.2)
4.67	(118.5)	100	1.17	(29.7)
4.65	(118.0)	103	1.15	(29.2)
4.63	(117.5)	106	1.13	(28.7)
4.61	(117.0)	109	1.11	(28.2)
4.59	(116.5)	112	1.09	(27.7)
4.57	(116.0)	115	1.07	(27.2)
4.55	(115.5)	118	1.05	(26.7)
4.53	(115.0)	121	1.03	(26.2)

**320S, 320 FM, 322FM, 323S, 324FM, 325, 325 FM, 329, 511, 521, 522, 1090, 1190, 1390, TK711, TK721, TK722, TK741 - 8.00 in. (203.2 mm)**

**Pins and Bushings <sup>(1)</sup>  
Internal Wear  
Sealed Track  
Grease Lubricated Track  
Heavy Duty**

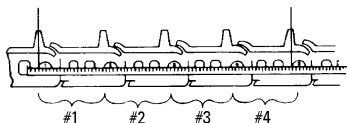

<b>Inches</b>	<b>(mm)</b>	<b>% Worn</b>
32.00	(813.0)	0
32.05	(814.0)	10
32.10	(815.5)	20
32.15	(816.5)	30
32.20	(818.0)	40
32.25	(819.0)	50
32.30	(820.5)	60
32.35	(821.5)	70
32.40	(823.0)	80
32.45	(824.0)	90
32.50	(825.5)	100
32.55	(827.0)	105
32.60	(828.0)	110
32.65	(829.5)	115
32.70	(830.5)	120

1 Wear Chart: 400

**320 S, 320 FM, 322 FM, 323S, 324 FM, 325, 329, 511, TK711, 1090 - 8.00 in. (203.2 mm)**

**Bushings <sup>(1)</sup>  
External Wear  
Grease Lubricated Track  
Use with 6Y-1607 & 08 or 261-1011 & 12 Links**

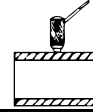

<b>Allowable Wear</b>					
<b>Caliper</b>		<b>Lesser</b>	<b>Greater</b>	<b>Ultrasonic</b>	
<b>Inches</b>	<b>(mm)</b>	<b>% Worn</b>	<b>% Worn</b>	<b>Inches</b>	<b>(mm)</b>
2.60	(66.0)	0	0	0.45	(11.4)
2.59	(65.8)	9	7	0.44	(11.2)
2.58	(65.5)	18	14	0.43	(10.9)
2.57	(65.3)	27	21	0.42	(10.7)
2.56	(65.0)	36	28	0.41	(10.4)
2.55	(64.8)	45	35	0.40	(10.2)
2.54	(64.5)	54	42	0.39	(9.9)
2.53	(64.3)	63	49	0.38	(9.7)
2.52	(64.0)	68	55	0.37	(9.4)
2.51	(63.8)	72	58	0.36	(9.1)
2.50	(63.5)	76	61	0.35	(8.9)
2.49	(63.2)	80	64	0.34	(8.6)
2.48	(63.0)	84	67	0.33	(8.4)
2.47	(62.7)	88	70	0.32	(8.1)
2.46	(62.5)	92	73	0.31	(7.9)
2.45	(62.2)	96	76	0.30	(7.6)
2.44	(62.0)	100	79	0.29	(7.4)
2.43	(61.7)	104	82	0.28	(7.1)
2.42	(61.5)	108	85	0.27	(6.9)
2.41	(61.2)	112	88	0.26	(6.6)
2.40	(61.0)	116	91	0.25	(6.4)
2.39	(60.7)	120	94	0.24	(6.1)
2.38	(60.5)		97	0.23	(5.8)
2.37	(60.2)		100	0.22	(5.6)
2.36	(59.9)		103	0.21	(5.3)
2.35	(59.7)		106	0.20	(5.1)
2.34	(59.4)		109	0.19	(4.8)
2.33	(59.2)		112	0.18	(4.6)
2.32	(58.9)		115	0.17	(4.3)
2.31	(58.7)		118	0.16	(4.1)
2.30	(58.4)		121	0.15	(3.8)

**320 S, 320 FM, 322 FM, 323S, 324 FM, 325, 329, 511, TK711, 1090 - 8.00 in. (203.2 mm)**

**Bushings<sup>(1)</sup>  
External Wear  
General Duty  
Use with 461-3805 & 06 Links**

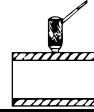

Caliper		Allowable Wear		Ultrasonic	
Inches	(mm)	Lesser % Worn	Greater % Worn	Inches	(mm)
2.52	(64.0)	0	0	0.41	(10.4)
2.51	(63.8)	9	7	0.40	(10.2)
2.50	(63.5)	18	14	0.39	(9.9)
2.49	(63.2)	27	21	0.38	(9.7)
2.48	(63.0)	36	28	0.37	(9.4)
2.47	(62.7)	45	35	0.36	(9.1)
2.46	(62.5)	54	42	0.35	(8.9)
2.45	(62.2)	63	49	0.34	(8.6)
2.44	(62.0)	68	55	0.33	(8.4)
2.43	(61.7)	72	58	0.32	(8.1)
2.42	(61.5)	76	61	0.31	(7.9)
2.41	(61.2)	80	64	0.30	(7.6)
2.40	(61.0)	84	67	0.29	(7.4)
2.39	(60.7)	88	70	0.28	(7.1)
2.38	(60.5)	92	73	0.27	(6.9)
2.37	(60.2)	96	76	0.26	(6.6)
2.36	(59.9)	100	79	0.25	(6.4)
2.35	(59.7)	104	82	0.24	(6.1)
2.34	(59.4)	108	85	0.23	(5.8)
2.33	(59.2)	112	88	0.22	(5.6)
2.32	(58.9)	116	91	0.21	(5.3)
2.31	(58.7)	120	94	0.20	(5.1)
2.30	(58.4)		97	0.19	(4.8)
2.29	(58.2)		100	0.18	(4.6)
2.28	(57.9)		103	0.17	(4.3)
2.27	(57.7)		106	0.16	(4.1)
2.26	(57.4)		109	0.15	(3.8)
2.25	(57.2)		112	0.14	(3.6)
2.24	(56.9)		115	0.13	(3.3)
2.23	(56.6)		118	0.12	(3.0)
2.22	(56.4)		121	0.11	(2.8)



**Bushings <sup>(1)</sup>**  
**External Wear**  
**Sealed Track**  
 Use with 6Y-1607 & 08 or 261-1011 & 12 Links

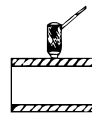
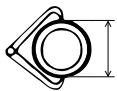

Allowable Wear					
Caliper		Lesser	Greater	Ultrasonic	
Inches	(mm)	% Worn	% Worn	Inches	(mm)
2.54	(64.5)	0	0	0.42	(10.7)
2.53	(64.3)	9	7	0.41	(10.4)
2.52	(64.0)	18	14	0.40	(10.2)
2.51	(63.8)	27	21	0.39	(9.9)
2.50	(63.5)	36	28	0.38	(9.7)
2.49	(63.2)	45	35	0.37	(9.4)
2.48	(63.0)	54	42	0.36	(9.1)
2.47	(62.7)	63	49	0.35	(8.9)
2.46	(62.5)	72	56	0.34	(8.6)
2.45	(62.2)	81	63	0.33	(8.4)
2.44	(62.0)	88	70	0.32	(8.1)
2.43	(61.7)	92	73	0.31	(7.9)
2.42	(61.5)	96	76	0.30	(7.6)
2.41	(61.2)	100	79	0.29	(7.4)
2.40	(61.0)	104	82	0.28	(7.1)
2.39	(61.7)	108	85	0.27	(6.9)
2.38	(60.5)	112	88	0.26	(6.6)
2.37	(60.2)	116	91	0.25	(6.4)
2.36	(60.9)	120	94	0.24	(6.1)
2.35	(59.7)		97	0.23	(5.8)
2.34	(59.4)		100	0.22	(5.6)
2.33	(59.2)		103	0.21	(5.3)
2.32	(58.9)		106	0.20	(5.1)
2.31	(58.7)		109	0.19	(4.8)
2.30	(58.4)		112	0.18	(4.6)
2.29	(58.2)		115	0.17	(4.3)
2.28	(57.9)		118	0.16	(4.1)
2.27	(57.7)		121	0.15	(3.8)

**324 FM, 325 FM, 521, 522, 1190, 1390, TK721, TK722, TK741 - 8.00 in. (203.2 mm)**

**Bushings<sup>(1)</sup>  
External Wear  
Heavy Duty**

Use with 8E-7405 & 06, 365-8401 & 02, or 431-2180 & 81 Links

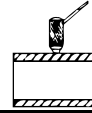

<b>Allowable Wear</b>					
<b>Caliper</b>		<b>Lesser</b>	<b>Greater</b>	<b>Ultrasonic</b>	
<b>Inches</b>	<b>(mm)</b>	<b>% Worn</b>	<b>% Worn</b>	<b>Inches</b>	<b>(mm)</b>
2.86	(72.6)	0	0	0.53	(13.5)
2.84	(72.1)	10	8	0.51	(13.0)
2.82	(71.6)	20	16	0.49	(12.4)
2.80	(71.1)	30	24	0.47	(11.9)
2.78	(70.6)	40	32	0.45	(11.4)
2.76	(70.1)	50	40	0.43	(10.9)
2.74	(69.6)	60	48	0.41	(10.4)
2.72	(69.1)	70	52	0.39	(9.9)
2.70	(68.6)	76	56	0.37	(9.4)
2.68	(68.1)	80	60	0.35	(8.9)
2.66	(67.6)	84	64	0.33	(8.4)
2.64	(67.1)	88	68	0.31	(7.9)
2.62	(66.5)	92	72	0.29	(7.4)
2.60	(66.0)	96	76	0.27	(6.9)
2.58	(65.5)	100	80	0.25	(6.3)
2.56	(65.0)	104	84	0.23	(5.8)
2.54	(64.5)	108	88	0.21	(5.3)
2.52	(64.0)	112	92	0.19	(4.8)
2.50	(63.5)	116	96	0.17	(4.3)
2.48	(63.0)	120	100	0.15	(3.8)
2.46	(62.5)	124	104	0.13	(3.3)
2.44	(62.0)	128	108	0.11	(2.8)
2.42	(61.5)	132	112	0.09	(2.3)
2.40	(61.0)	136	116	0.07	(1.8)
2.38	(60.5)	140	120	0.05	(1.3)

**Track Shoes <sup>(1)</sup>  
Extreme Service**

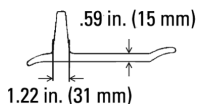
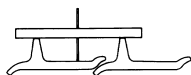

Depth Gauge			Ultrasonic		
Inches	(mm)	% Worn	Inches	(mm)	
2.95	(75.0)	0	3.54	(90.0)	
2.90	(73.5)	4	3.49	(88.7)	
2.85	(72.5)	8	3.44	(87.5)	
2.80	(71.0)	12	3.39	(86.2)	
2.75	(70.0)	16	3.34	(84.9)	
2.70	(68.5)	20	3.29	(83.7)	
2.65	(67.5)	24	3.24	(82.4)	
2.60	(66.0)	28	3.19	(81.1)	
2.55	(65.0)	32	3.14	(79.8)	
2.50	(63.5)	36	3.09	(78.6)	
2.45	(62.0)	40	3.04	(77.3)	
2.40	(61.0)	44	2.99	(76.0)	
2.35	(59.5)	48	2.94	(74.8)	
2.30	(58.5)	52	2.89	(73.5)	
2.25	(57.0)	55	2.84	(72.2)	
2.20	(56.0)	58	2.79	(71.0)	
2.15	(54.5)	61	2.74	(69.7)	
2.10	(53.5)	64	2.69	(68.4)	
2.05	(52.0)	67	2.64	(67.1)	
2.00	(51.0)	70	2.59	(65.9)	
1.95	(49.5)	73	2.54	(64.6)	
1.90	(48.5)	76	2.49	(63.3)	
1.85	(47.0)	79	2.44	(62.1)	
1.80	(45.5)	82	2.39	(60.8)	
1.75	(44.5)	85	2.34	(59.5)	
1.70	(43.0)	88	2.29	(58.3)	
1.65	(42.0)	91	2.24	(57.0)	
1.60	(40.5)	94	2.19	(55.7)	
1.55	(39.5)	97	2.14	(54.4)	
1.50	(38.0)	100	2.09	(53.2)	
1.45	(37.0)	103	2.04	(51.9)	
1.40	(35.5)	106	1.99	(50.6)	
1.35	(34.5)	109	1.94	(49.4)	
1.30	(33.0)	112	1.89	(48.1)	
1.25	(32.0)	115	1.84	(46.8)	
1.20	(30.5)	118	1.79	(45.6)	
1.15	(29.0)	121	1.74	(44.3)	

**320 S, 320 FM, 322 FM, 323S, 324 FM, 325, 325 FM, 329, 511, 521, 522, 1090, 1190, 1390, TK711, TK721, TK722, TK741 - 8.00 in. (203.2 mm)**

**Track Shoes <sup>(1)</sup>  
Double Grouser**

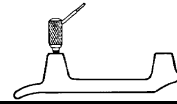
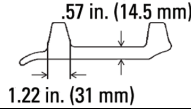
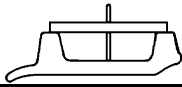

**Depth Gauge**

**Ultrasonic**

<b>Inches</b>	<b>(mm)</b>	<b>% Worn</b>	<b>Inches</b>	<b>(mm)</b>
1.65	(42.0)	0	2.22	(56.5)
1.60	(40.5)	6	2.17	(55.2)
1.55	(39.5)	12	2.12	(54.0)
1.50	(38.0)	18	2.07	(52.7)
1.45	(37.0)	24	2.02	(51.4)
1.40	(35.5)	30	1.97	(50.2)
1.35	(34.5)	36	1.92	(48.9)
1.30	(33.0)	42	1.87	(47.6)
1.25	(32.0)	48	1.82	(46.3)
1.20	(30.5)	54	1.77	(45.1)
1.15	(29.0)	60	1.72	(43.8)
1.10	(28.0)	65	1.67	(42.5)
1.05	(26.5)	70	1.62	(41.3)
1.00	(25.5)	75	1.57	(40.0)
0.95	(24.0)	80	1.52	(38.7)
0.90	(23.0)	85	1.47	(37.5)
0.85	(21.5)	90	1.42	(36.2)
0.80	(20.5)	95	1.37	(34.9)
0.75	(19.0)	100	1.32	(33.6)
0.70	(18.0)	105	1.27	(32.4)
0.65	(16.5)	110	1.22	(31.1)
0.60	(15.0)	115	1.17	(29.8)
0.55	(14.0)	120	1.12	(28.6)

**Track Shoes <sup>(1)</sup>  
Heavy Duty Triple Grouser**

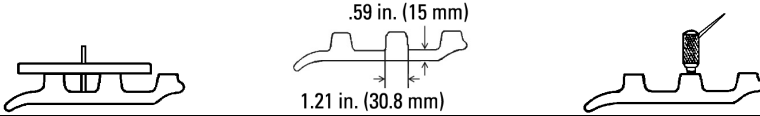

Depth Gauge			Ultrasonic	
Inches	(mm)	% Worn	Inches	(mm)
1.05	(26.5)	0	1.65	(41.9)
1.00	(25.5)	10	1.60	(40.6)
0.95	(24.0)	19	1.55	(39.4)
0.90	(23.0)	28	1.50	(38.1)
0.85	(21.5)	37	1.45	(36.8)
0.80	(20.5)	46	1.40	(35.6)
0.75	(19.0)	55	1.35	(34.3)
0.70	(18.0)	64	1.30	(33.0)
0.65	(16.5)	73	1.25	(31.8)
0.60	(15.0)	82	1.20	(30.5)
0.55	(14.0)	91	1.15	(29.2)
0.50	(12.5)	100	1.10	(27.9)
0.45	(11.5)	109	1.05	(26.7)
0.40	(10.0)	118	1.00	(25.4)
0.35	(9.0)	127	0.95	(24.1)

**Track Shoes <sup>(1)</sup>  
Triple Grouser  
Genuine and General Duty**

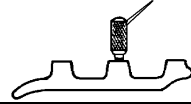
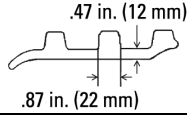
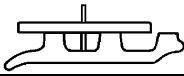

**Depth Gauge**

**Ultrasonic**

Inches	(mm)	% Worn	Inches	(mm)
1.10	(28.0)	0	1.57	(40.0)
1.05	(26.5)	9	1.52	(38.7)
1.00	(25.5)	18	1.47	(37.5)
0.95	(24.0)	27	1.42	(36.2)
0.90	(23.0)	36	1.37	(34.9)
0.85	(21.5)	44	1.32	(33.7)
0.80	(20.5)	52	1.27	(32.4)
0.75	(19.0)	60	1.22	(31.1)
0.70	(18.0)	68	1.17	(29.8)
0.65	(16.5)	76	1.12	(28.6)
0.60	(15.0)	84	1.07	(27.3)
0.55	(14.0)	92	1.02	(26.0)
0.50	(12.5)	100	0.97	(24.8)
0.45	(11.5)	108	0.92	(23.5)
0.40	(10.0)	116	0.87	(22.2)
0.35	(9.0)	124	0.82	(21.0)

1 Wear Chart: 2803

**320 S, 322 FM, 323S, 324 FM, 325, 325 FM, 329, 511, TK711, 1090 - 8.00 in. (203.2 mm)**

**Idlers <sup>(1) (2) (3)</sup>  
Genuine and General Duty  
Not for use on 521, 522, 1190, 1390, TK721, TK722, TK741**

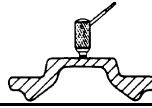
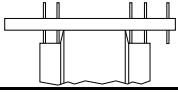

Depth Gauge		
Inches	(mm)	% Worn
0.78	(20.0)	0
0.80	(20.5)	12
0.82	(21.0)	24
0.84	(21.5)	36
0.86	(22.0)	44
0.88	(22.5)	48
0.90	(23.0)	52
0.92	(23.5)	56
0.94	(24.0)	60
0.96	(24.5)	64
0.98	(25.0)	68
1.00	(25.5)	72
1.02	(26.0)	76
1.04	(26.5)	80
1.06	(27.0)	84
1.08	(27.5)	88
1.10	(28.0)	92
1.12	(28.5)	96
1.14	(29.0)	100
1.16	(29.5)	104
1.18	(30.0)	108
1.20	(30.5)	112
1.22	(31.0)	116
1.24	(31.5)	120

Ultrasonic		Center Flange Wear	
Inches	(mm)	Inches	(mm)
0.49	(12.4)	0.00	(0.0)
0.47	(11.9)	0.02	(0.5)
0.45	(11.4)	0.04	(1.0)
0.43	(10.9)	0.06	(1.5)
0.41	(10.4)	0.08	(2.0)
0.39	(9.9)	0.10	(2.5)
0.37	(9.4)	0.12	(3.0)
0.35	(8.9)	0.14	(3.5)
0.33	(8.4)	0.16	(4.0)
0.31	(7.9)	0.18	(4.5)
0.29	(7.4)	0.20	(5.0)
0.27	(6.9)	0.22	(5.5)
0.25	(6.3)	0.24	(6.0)
0.23	(5.8)	0.26	(6.5)
0.21	(5.3)	0.28	(7.0)
0.19	(4.8)	0.30	(7.5)
0.17	(4.3)	0.32	(8.0)
0.15	(3.8)	0.34	(8.5)
0.13	(3.3)	0.36	(9.0)
0.11	(2.8)	0.38	(9.5)
0.09	(2.3)	0.40	(10.0)
0.07	(1.8)	0.42	(10.5)
0.05	(1.3)	0.44	(11.0)
0.03	(0.8)	0.46	(11.5)

**NOTE**

Ultrasonic measurement is to determine flange wear only. Do not use on General Duty Idlers.

- 1 Flange width is 3.74 in. (95 mm)
- 2 New tread diameter is 21.26 in. (540 mm) or 21.73 in. (552 mm)
- 3 Wear Chart: 4405

# 521, 522, 1190, 1390, TK721, TK722, TK741 - 8.00 in. (203.2 mm)

Idlers <sup>(1)</sup> <sup>(2)</sup> <sup>(3)</sup>  
 Only for use on 521, 522, 1190, 1390, TK721, TK722, TK741

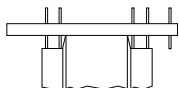

**Depth Gauge**

Inches	(mm)	% Worn
0.94	(24.0)	0
0.98	(25.0)	8
1.02	(26.0)	16
1.06	(27.0)	24
1.10	(28.0)	32
1.14	(29.0)	40
1.18	(30.0)	48
1.22	(31.0)	52
1.26	(32.0)	56
1.30	(33.0)	60
1.34	(34.0)	64
1.38	(35.0)	68
1.42	(36.0)	72
1.46	(37.0)	76
1.50	(38.0)	80
1.54	(39.0)	84
1.58	(40.0)	88
1.62	(41.0)	92
1.66	(42.0)	96
1.70	(43.0)	100
1.74	(44.0)	104
1.78	(45.0)	108
1.82	(46.0)	112
1.86	(47.0)	116
1.90	(48.5)	120

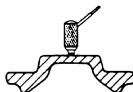

**Ultrasonic**

**Center Flange Wear**

Inches	(mm)	Inches	(mm)
0.49	(12.4)	0.00	(0.0)
0.45	(11.4)	0.04	(1.0)
0.41	(10.4)	0.08	(2.0)
0.37	(9.4)	0.12	(3.0)
0.33	(8.4)	0.16	(4.0)
0.29	(7.4)	0.20	(5.0)
0.25	(6.4)	0.24	(6.0)
0.21	(5.3)	0.28	(7.0)
0.17	(4.3)	0.32	(8.0)
0.13	(3.3)	0.36	(9.0)
0.09	(2.3)	0.40	(10.0)
0.05	(1.3)	0.44	(11.0)
0.01	(0.3)	0.48	(12.0)

**NOTE**

Ultrasonic measurement is to determine flange wear only.

- 1 Flange width is 3.74 in. (95 mm)
- 2 New tread diameter is 22.44 in. (570 mm)
- 3 Wear Chart: 4406



**Idlers <sup>(1)</sup> <sup>(2)</sup> <sup>(3)</sup>**  
**Only for use on 320D FM**

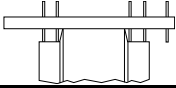

Depth Gauge		
Inches	(mm)	% Worn
0.74	(19.0)	0
0.76	(19.5)	12
0.78	(20.0)	24
0.80	(20.5)	36
0.82	(21.0)	48
0.84	(21.5)	60
0.86	(22.0)	72
0.88	(22.5)	76
0.90	(23.0)	80
0.92	(23.5)	84
0.94	(24.0)	88
0.96	(24.5)	92
0.98	(25.0)	96
1.00	(25.5)	100
1.02	(26.0)	104
1.04	(26.5)	108
1.06	(27.0)	112
1.08	(27.5)	116
1.10	(28.0)	120



Ultrasonic		Center Flange Wear	
Inches	(mm)	Inches	(mm)
0.40	(10.2)	0.00	(0.0)
0.38	(9.7)	0.02	(0.5)
0.36	(9.1)	0.04	(1.0)
0.34	(8.6)	0.06	(1.5)
0.32	(8.1)	0.08	(2.0)
0.30	(7.6)	0.10	(2.5)
0.28	(7.1)	0.12	(3.0)
0.26	(6.6)	0.14	(3.5)
0.24	(6.1)	0.16	(4.0)
0.22	(5.6)	0.18	(4.5)
0.20	(5.1)	0.20	(5.0)
0.18	(4.6)	0.22	(5.5)
0.16	(4.1)	0.24	(6.0)
0.14	(3.6)	0.26	(6.5)
0.12	(3.0)	0.28	(7.0)
0.10	(2.5)	0.30	(7.5)
0.08	(2.0)	0.32	(8.0)
0.06	(1.5)	0.34	(8.5)
0.04	(1.0)	0.36	(9.0)

**NOTE**

Ultrasonic measurement is to determine flange wear only. Use the ultrasonic only on fabricated idlers.

- 1 Flange width is 3.09 in. (78.4 mm)
- 2 New tread diameter is 19.73 in. (507 mm)
- 3 Wear Chart: 4384

## 320 S, 323S, 325, 329 - 8.00 in. (203.2 mm)

### Carrier Rollers <sup>(1)</sup>

Not for use on 322 FM, 324 FM, 325 FM, 511, 521, 522, TK711, TK721, TK722, TK741, 1090  
Genuine and General Duty

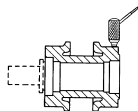
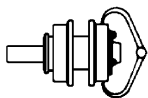

Caliper			Ultrasonic	
Inches	(mm)	% Worn	Inches	(mm)
6.30	(160.0)	0	1.62	(41.1)
6.26	(159.0)	6	1.60	(40.6)
6.22	(158.0)	12	1.58	(40.1)
6.18	(157.0)	18	1.56	(39.6)
6.14	(156.0)	24	1.54	(39.1)
6.10	(155.0)	30	1.52	(38.6)
6.06	(154.0)	36	1.50	(38.1)
6.02	(153.0)	40	1.48	(37.6)
5.98	(152.0)	44	1.46	(37.1)
5.94	(151.0)	48	1.44	(36.6)
5.90	(150.0)	52	1.42	(36.1)
5.86	(149.0)	56	1.40	(35.6)
5.82	(148.0)	60	1.38	(35.1)
5.78	(147.0)	64	1.36	(34.5)
5.74	(146.0)	68	1.34	(34.0)
5.70	(145.0)	72	1.32	(33.5)
5.66	(144.0)	76	1.30	(33.0)
5.62	(142.5)	80	1.28	(32.5)
5.58	(141.5)	84	1.26	(32.0)
5.54	(140.5)	88	1.24	(31.5)
5.50	(139.5)	92	1.22	(31.0)
5.46	(138.5)	96	1.20	(30.5)
5.42	(137.5)	100	1.18	(30.0)
5.38	(136.5)	104	1.16	(29.5)
5.34	(135.5)	108	1.14	(29.0)
5.30	(134.5)	112	1.12	(28.4)
5.26	(133.5)	116	1.10	(27.9)
5.22	(132.5)	120	1.08	(27.4)

#### NOTE

For 322FM, 324FM, 325 FM, 511, 521, 522, TK711, TK721, TK722, TK741, 1090, use Track Roller wear chart for Carrier Rollers.

**Track Rollers <sup>(1) (2)</sup>  
Genuine and General Duty**

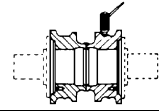

Caliper		% Worn	Depth Gauge		Ultrasonic	
Inches	(mm)		Inches	(mm)	Inches	(mm)
6.30	(160.0)	0	0.69	(17.5)	1.73	(43.9)
6.26	(159.0)	8	0.71	(18.0)	1.71	(43.4)
6.22	(158.0)	16	0.73	(18.5)	1.69	(42.9)
6.18	(157.0)	24	0.75	(19.0)	1.67	(42.4)
6.14	(156.0)	32	0.77	(19.5)	1.65	(41.9)
6.10	(155.0)	40	0.79	(20.0)	1.63	(41.4)
6.06	(154.0)	48	0.81	(20.5)	1.61	(40.9)
6.02	(153.0)	56	0.83	(21.0)	1.59	(40.4)
5.98	(152.0)	64	0.85	(21.5)	1.57	(39.9)
5.94	(151.0)	68	0.87	(22.0)	1.55	(39.4)
5.90	(150.0)	72	0.89	(22.5)	1.53	(38.9)
5.86	(149.0)	76	0.91	(23.0)	1.51	(38.4)
5.82	(148.0)	80	0.93	(23.5)	1.49	(37.8)
5.78	(147.0)	84	0.95	(24.0)	1.47	(37.3)
5.74	(146.0)	88	0.97	(24.5)	1.45	(36.8)
5.70	(145.0)	92	0.99	(25.0)	1.43	(36.3)
5.66	(144.0)	96	1.01	(25.5)	1.41	(35.8)
5.62	(142.5)	100	1.03	(26.0)	1.39	(35.3)
5.58	(141.5)	104	1.05	(26.5)	1.37	(34.8)
5.54	(140.5)	108	1.07	(27.0)	1.35	(34.3)
5.50	(139.5)	112	1.09	(27.5)	1.33	(33.8)
5.46	(138.5)	116	1.11	(28.0)	1.31	(33.3)
5.42	(137.5)	120	1.13	(28.5)	1.29	(32.8)

1 Flange diameter is 7.68 in. (195 mm)  
2 Wear Chart: 5310

# 320D FM - 8.00 in. (203.2 mm)

## Track Rollers <sup>(1) (2)</sup> Use only on 320D FM for Carrier Rollers and Track Rollers

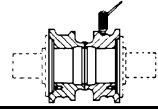
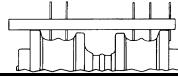
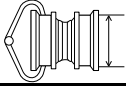

Caliper		% Worn	Depth Gauge		Ultrasonic	
Inches	(mm)		Inches	(mm)	Inches	(mm)
5.90	(150.0)	0	0.69	(17.5)	1.69	(42.9)
5.86	(149.0)	7	0.71	(18.0)	1.67	(42.4)
5.82	(148.0)	14	0.73	(18.5)	1.65	(41.9)
5.78	(147.0)	21	0.75	(19.0)	1.63	(41.4)
5.74	(146.0)	28	0.77	(19.5)	1.61	(40.9)
5.70	(145.0)	35	0.79	(20.0)	1.59	(40.4)
5.66	(144.0)	42	0.81	(20.5)	1.57	(39.9)
5.62	(142.5)	49	0.83	(21.0)	1.55	(39.4)
5.58	(141.5)	56	0.85	(21.5)	1.53	(38.9)
5.54	(140.5)	63	0.87	(22.0)	1.51	(38.4)
5.50	(139.5)	70	0.89	(22.5)	1.49	(37.8)
5.46	(138.5)	76	0.91	(23.0)	1.47	(37.3)
5.42	(137.5)	80	0.93	(23.5)	1.45	(36.8)
5.38	(136.5)	84	0.95	(24.0)	1.43	(36.3)
5.34	(135.5)	88	0.97	(24.5)	1.41	(35.8)
5.30	(134.5)	92	0.99	(25.0)	1.39	(35.3)
5.26	(133.5)	96	1.01	(25.5)	1.37	(34.8)
5.22	(132.5)	100	1.03	(26.0)	1.35	(34.3)
5.18	(131.5)	104	1.05	(26.5)	1.33	(33.8)
5.14	(130.5)	108	1.07	(27.0)	1.31	(33.3)
5.10	(129.5)	112	1.09	(27.5)	1.29	(32.8)
5.06	(128.5)	116	1.11	(28.0)	1.27	(32.3)
5.02	(127.5)	120	1.13	(28.5)	1.25	(31.8)

1 Flange diameter is 7.28 in. (185 mm)

2 Wear Chart: 5285

**328, 330, 330 FM, 336, 340, 532, 541, 1290, 1390, TK732 - 8.50 in. (215.9 mm)**

**Track Links <sup>(1)</sup>  
Genuine and General Duty  
6Y-2589 & 90  
449-2675 & 76**

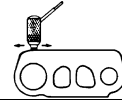
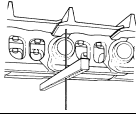

Depth Gauge			Ultrasonic	
Inches	(mm)	% Worn	Inches	(mm)
4.88	(124.0)	0	1.36	(34.5)
4.86	(123.5)	7	1.34	(34.0)
4.84	(123.0)	14	1.32	(33.5)
4.82	(122.5)	21	1.30	(33.0)
4.80	(122.0)	28	1.28	(32.5)
4.78	(121.5)	35	1.26	(32.0)
4.76	(121.0)	42	1.24	(31.5)
4.74	(120.5)	49	1.22	(31.0)
4.72	(120.0)	56	1.20	(30.5)
4.70	(119.5)	63	1.18	(30.0)
4.68	(119.0)	68	1.16	(29.5)
4.66	(118.5)	72	1.14	(29.0)
4.64	(118.0)	76	1.12	(28.4)
4.62	(117.5)	80	1.10	(27.9)
4.60	(117.0)	84	1.08	(27.4)
4.58	(116.5)	88	1.06	(26.9)
4.56	(116.0)	92	1.04	(26.4)
4.54	(115.5)	96	1.02	(25.9)
4.52	(115.0)	100	1.00	(25.4)
4.50	(114.5)	104	0.98	(24.9)
4.48	(114.0)	108	0.96	(24.4)
4.46	(113.5)	112	0.94	(23.9)
4.44	(113.0)	116	0.92	(23.4)
4.42	(112.5)	120	0.90	(22.9)

**Pins and Bushings <sup>(1)</sup>  
Internal Wear  
Sealed Track  
Grease Lubricated Track  
Genuine & General Duty**

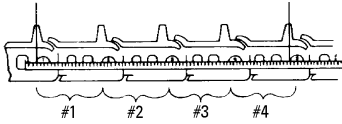

<b>Inches</b>	<b>(mm)</b>	<b>% Worn</b>
34.05	(865.0)	0
34.10	(866.0)	10
34.15	(867.5)	20
34.20	(868.5)	30
34.25	(870.0)	40
34.30	(871.0)	50
34.35	(872.5)	60
34.40	(874.0)	70
34.45	(875.0)	80
34.50	(876.5)	90
34.55	(877.5)	100
34.60	(879.0)	105
34.65	(880.0)	110
34.70	(881.5)	115
34.75	(882.5)	120

1 Wear Chart: 420

**Bushings <sup>(1)</sup>  
External Wear  
Grease Lubricated Track**

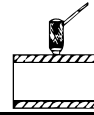

Caliper		Allowable Wear		Ultrasonic	
Inches	(mm)	Lesser % Worn	Greater % Worn	Inches	(mm)
2.75	(69.9)	0	0	0.45	(11.4)
2.74	(69.6)	9	7	0.44	(11.2)
2.73	(69.3)	18	14	0.43	(10.9)
2.72	(69.1)	27	21	0.42	(10.7)
2.71	(68.8)	36	28	0.41	(10.4)
2.70	(68.6)	45	35	0.40	(10.2)
2.69	(68.3)	54	42	0.39	(9.9)
2.68	(68.1)	63	49	0.38	(9.7)
2.67	(67.8)	68	55	0.37	(9.4)
2.66	(67.6)	72	58	0.36	(9.1)
2.65	(67.3)	76	61	0.35	(8.9)
2.64	(67.1)	80	64	0.34	(8.6)
2.63	(66.8)	84	67	0.33	(8.4)
2.62	(66.5)	88	70	0.32	(8.1)
2.61	(66.3)	92	73	0.31	(7.9)
2.60	(66.0)	96	76	0.30	(7.6)
2.59	(65.8)	100	79	0.29	(7.4)
2.58	(65.5)	104	82	0.28	(7.1)
2.57	(65.3)	108	85	0.27	(6.9)
2.56	(65.0)	112	88	0.26	(6.6)
2.55	(64.8)	116	91	0.25	(6.4)
2.54	(64.5)	120	94	0.24	(6.1)
2.53	(64.3)		97	0.23	(5.8)
2.52	(64.0)		100	0.22	(5.6)
2.51	(63.8)		103	0.21	(5.3)
2.50	(63.5)		106	0.20	(5.1)
2.49	(63.2)		109	0.19	(4.8)
2.48	(63.0)		112	0.18	(4.6)
2.47	(62.7)		115	0.17	(4.3)
2.46	(62.5)		118	0.16	(4.1)
2.45	(62.2)		121	0.15	(3.8)

**Bushings <sup>(1)</sup>  
External Wear  
General Duty  
Use with 449-2675 & 76 Links**

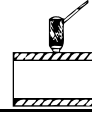
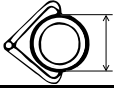

Caliper		Allowable Wear		Ultrasonic	
Inches	(mm)	Lesser % Worn	Greater % Worn	Inches	(mm)
2.68	(68.1)	0	0	0.41	(10.4)
2.67	(67.8)	9	7	0.40	(10.2)
2.66	(67.6)	18	14	0.39	(9.9)
2.65	(67.3)	27	21	0.38	(9.7)
2.64	(67.1)	36	28	0.37	(9.4)
2.63	(66.8)	45	35	0.36	(9.1)
2.62	(66.5)	54	42	0.35	(8.9)
2.61	(66.3)	63	49	0.34	(8.6)
2.60	(66.0)	68	55	0.33	(8.4)
2.59	(65.8)	72	58	0.32	(8.1)
2.58	(65.5)	76	61	0.31	(7.9)
2.57	(65.3)	80	64	0.30	(7.6)
2.56	(65.0)	84	67	0.29	(7.4)
2.55	(64.8)	88	70	0.28	(7.1)
2.54	(64.5)	92	73	0.27	(6.9)
2.53	(64.3)	96	76	0.26	(6.6)
2.52	(64.0)	100	79	0.25	(6.4)
2.51	(63.8)	104	82	0.24	(6.1)
2.50	(63.5)	108	85	0.23	(5.8)
2.49	(63.2)	112	88	0.22	(5.6)
2.48	(63.0)	116	91	0.21	(5.3)
2.47	(62.7)	120	94	0.20	(5.1)
2.46	(62.5)		97	0.19	(4.8)
2.45	(62.2)		100	0.18	(4.6)
2.44	(62.0)		103	0.17	(4.3)
2.43	(61.7)		106	0.16	(4.1)
2.42	(61.5)		109	0.15	(3.8)
2.41	(61.2)		112	0.14	(3.6)
2.40	(61.0)		115	0.13	(3.3)
2.39	(60.7)		118	0.12	(3.0)
2.38	(60.5)		121	0.11	(2.8)



**Bushings <sup>(1)</sup>  
External Wear  
Sealed Track**

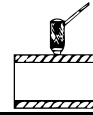

Caliper		Allowable Wear		Ultrasonic	
Inches	(mm)	Lesser % Worn	Greater % Worn	Inches	(mm)
2.70	(68.6)	0	0	0.42	(10.7)
2.69	(68.3)	9	7	0.41	(10.4)
2.68	(68.1)	18	14	0.40	(10.2)
2.67	(67.8)	27	21	0.39	(9.9)
2.66	(67.6)	36	28	0.38	(9.7)
2.65	(67.3)	45	35	0.37	(9.4)
2.64	(67.1)	54	42	0.36	(9.1)
2.63	(66.8)	63	49	0.35	(8.9)
2.62	(66.5)	72	56	0.34	(8.6)
2.61	(66.3)	81	63	0.33	(8.4)
2.60	(66.0)	88	70	0.32	(8.1)
2.59	(65.8)	92	73	0.31	(7.9)
2.58	(65.5)	96	76	0.30	(7.6)
2.57	(65.3)	100	79	0.29	(7.4)
2.56	(65.0)	104	82	0.28	(7.1)
2.55	(64.8)	108	85	0.27	(6.9)
2.54	(64.5)	112	88	0.26	(6.6)
2.53	(64.3)	116	91	0.25	(6.4)
2.52	(64.0)	120	94	0.24	(6.1)
2.51	(63.8)		97	0.23	(5.8)
2.50	(63.5)		100	0.22	(5.6)
2.49	(63.2)		103	0.21	(5.3)
2.48	(63.0)		106	0.20	(5.1)
2.47	(62.7)		109	0.19	(4.8)
2.46	(62.5)		112	0.18	(4.6)
2.45	(62.2)		115	0.17	(4.3)
2.44	(62.0)		118	0.16	(4.1)
2.43	(61.7)		121	0.15	(3.8)

**328, 330, 330 FM, 336, 340, 532, 541, 1290, 1390, TK732 - 8.50 in. (215.9 mm)**

**Track Shoes <sup>(1)</sup>  
Extreme Service**



Depth Gauge			Ultrasonic		
Inches	(mm)	% Worn	Inches	(mm)	
2.80	(71.0)	0	3.50	(88.9)	
2.70	(68.5)	8	3.40	(86.4)	
2.60	(66.0)	16	3.30	(83.8)	
2.50	(63.5)	24	3.20	(81.3)	
2.40	(61.0)	32	3.10	(78.7)	
2.30	(58.5)	40	3.00	(76.2)	
2.20	(56.0)	48	2.90	(73.7)	
2.10	(53.5)	56	2.80	(71.1)	
2.00	(51.0)	64	2.70	(68.6)	
1.90	(48.5)	72	2.60	(66.0)	
1.80	(45.5)	79	2.50	(63.5)	
1.70	(43.0)	86	2.40	(61.0)	
1.60	(40.5)	93	2.30	(58.4)	
1.50	(38.0)	100	2.20	(55.9)	
1.40	(35.5)	107	2.10	(53.3)	
1.30	(33.0)	114	2.00	(50.8)	
1.20	(30.5)	121	1.90	(48.3)	

**328, 330, 330 FM, 336, 340, 1290, 1390 - 8.50 in. (215.9 mm)**

**Track Shoes <sup>(1)</sup>  
Double Grouser**

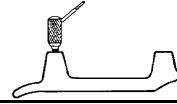
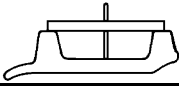
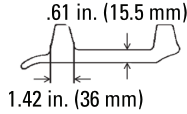

Depth Gauge			Ultrasonic	
Inches	(mm)	% Worn	Inches	(mm)
1.95	(49.5)	0	2.55	(64.8)
1.90	(48.5)	5	2.50	(63.5)
1.85	(47.0)	10	2.45	(62.2)
1.80	(45.5)	15	2.40	(61.0)
1.75	(44.5)	20	2.35	(59.7)
1.70	(43.0)	24	2.30	(58.4)
1.65	(42.0)	28	2.25	(57.2)
1.60	(40.5)	32	2.20	(55.9)
1.55	(39.5)	36	2.15	(54.6)
1.50	(38.0)	40	2.10	(53.3)
1.45	(37.0)	44	2.05	(52.1)
1.40	(35.5)	48	2.00	(50.8)
1.35	(34.5)	52	1.95	(49.5)
1.30	(33.0)	56	1.90	(48.3)
1.25	(32.0)	60	1.85	(47.0)
1.20	(30.5)	64	1.80	(45.7)
1.15	(29.0)	68	1.75	(44.5)
1.10	(28.0)	72	1.70	(43.2)
1.05	(26.5)	76	1.65	(41.9)
1.00	(25.5)	80	1.60	(40.6)
0.95	(24.0)	84	1.55	(39.4)
0.90	(23.0)	88	1.50	(38.1)
0.85	(21.5)	92	1.45	(36.8)
0.80	(20.5)	96	1.40	(35.6)
0.75	(19.0)	100	1.35	(34.3)
0.70	(18.0)	104	1.30	(33.0)
0.65	(16.5)	108	1.25	(31.8)
0.60	(15.0)	112	1.20	(30.5)
0.55	(14.0)	116	1.15	(29.2)
0.50	(12.5)	120	1.10	(27.9)

**328, 330, 330 FM, 336, 340, 1290, 1390 - 8.50 in. (215.9 mm)**

**Track Shoes <sup>(1)</sup>  
Heavy Duty Triple Grouser**

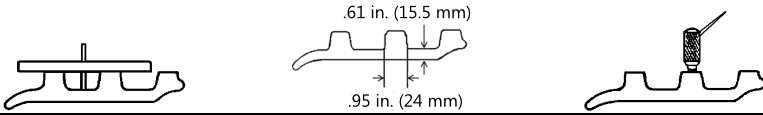

Depth Gauge			Ultrasonic		
Inches	(mm)	% Worn	Inches	(mm)	
1.35	(34.5)	0	1.95	(49.5)	
1.30	(33.0)	6	1.90	(48.2)	
1.25	(32.0)	12	1.85	(47.0)	
1.20	(30.5)	18	1.80	(45.7)	
1.15	(29.0)	24	1.75	(44.4)	
1.10	(28.0)	30	1.70	(43.2)	
1.05	(26.5)	36	1.65	(41.9)	
1.00	(25.5)	42	1.60	(40.6)	
0.95	(24.0)	48	1.55	(39.3)	
0.90	(23.0)	54	1.50	(38.1)	
0.85	(21.5)	60	1.45	(36.8)	
0.80	(20.5)	66	1.40	(35.5)	
0.75	(19.0)	72	1.35	(34.3)	
0.70	(18.0)	78	1.30	(33.0)	
0.65	(16.5)	84	1.25	(31.7)	
0.60	(15.0)	90	1.20	(30.5)	
0.55	(14.0)	95	1.15	(29.2)	
0.50	(12.5)	100	1.10	(27.9)	
0.45	(11.5)	105	1.05	(26.6)	
0.40	(10.0)	110	1.00	(25.4)	
0.35	(9.0)	115	0.95	(24.1)	
0.30	(7.5)	120	0.90	(22.8)	

**Track Shoes <sup>(1)</sup>  
Triple Grouser  
Genuine and General Duty**

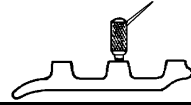
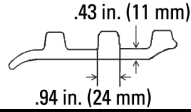
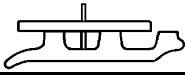

**Depth Gauge**

**Ultrasonic**

Inches	(mm)	% Worn	Inches	(mm)
1.20	(30.5)	0	1.65	(41.9)
1.15	(29.0)	8	1.60	(40.6)
1.10	(28.0)	16	1.55	(39.4)
1.05	(26.5)	23	1.50	(38.1)
1.00	(25.5)	30	1.45	(36.8)
0.95	(24.0)	37	1.40	(35.6)
0.90	(23.0)	44	1.35	(34.3)
0.85	(21.5)	51	1.30	(33.0)
0.80	(20.5)	58	1.25	(31.8)
0.75	(19.0)	65	1.20	(30.5)
0.70	(18.0)	72	1.15	(29.2)
0.65	(16.5)	79	1.10	(27.9)
0.60	(15.0)	86	1.05	(26.7)
0.55	(14.0)	93	1.00	(25.4)
0.50	(12.5)	100	0.95	(24.1)
0.45	(11.5)	107	0.90	(22.9)
0.40	(10.0)	114	0.85	(21.6)
0.35	(9.0)	121	0.80	(20.3)

**328, 330, 330 FM, 336, 340, 1290, 1390 - 8.50 in. (215.9 mm)**

**Track Shoes <sup>(1)</sup>  
Self Cleaning**



**Depth Gauge**

<b>Inches</b>	<b>(mm)</b>	<b>% Worn</b>
3.93	(100.0)	0
3.91	(99.5)	5
3.89	(99.0)	10
3.87	(98.5)	15
3.85	(98.0)	20
3.83	(97.5)	25
3.81	(97.0)	30
3.79	(96.5)	35
3.77	(96.0)	40
3.75	(95.5)	45
3.73	(94.5)	50
3.71	(94.0)	55
3.69	(93.5)	60
3.67	(93.0)	65
3.65	(92.5)	70
3.63	(92.0)	75
3.61	(91.5)	80
3.59	(91.0)	84
3.57	(90.5)	88
3.55	(90.0)	92
3.53	(89.5)	96
3.51	(89.0)	100
3.49	(88.5)	104
3.47	(88.0)	108
3.45	(87.5)	112
3.43	(87.0)	116
3.41	(86.5)	120

1 Wear Chart: 1922

**Idlers <sup>(1) (2) (3)</sup>  
Genuine and General Duty**

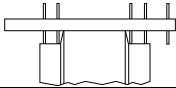

**Depth Gauge**

Inches	(mm)	% Worn
0.78	(20.0)	0
0.80	(20.5)	7
0.82	(21.0)	14
0.84	(21.5)	21
0.86	(22.0)	28
0.88	(22.5)	35
0.90	(23.0)	40
0.92	(23.5)	45
0.94	(24.0)	50
0.96	(24.5)	55
0.98	(25.0)	60
1.00	(25.5)	65
1.02	(26.0)	70
1.04	(26.5)	75
1.06	(27.0)	80
1.08	(27.5)	85
1.10	(28.0)	90
1.12	(28.5)	95
1.14	(29.0)	100
1.16	(29.5)	105
1.18	(30.0)	110
1.20	(30.5)	115
1.22	(31.0)	120



**Ultrasonic**

**Center Flange Wear**

Inches	(mm)	Inches	(mm)
0.48	(12.2)	0.00	(0.0)
0.46	(11.7)	0.02	(0.5)
0.44	(11.2)	0.04	(1.0)
0.42	(10.7)	0.06	(1.5)
0.40	(10.2)	0.08	(2.0)
0.38	(9.7)	0.10	(2.5)
0.36	(9.1)	0.12	(3.0)
0.34	(8.6)	0.14	(3.5)
0.32	(8.1)	0.16	(4.0)
0.30	(7.6)	0.18	(4.5)
0.28	(7.1)	0.20	(5.0)
0.26	(6.6)	0.22	(5.5)
0.24	(6.1)	0.24	(6.0)
0.22	(5.6)	0.26	(6.5)
0.20	(5.1)	0.28	(7.0)
0.18	(4.6)	0.30	(7.5)
0.16	(4.1)	0.32	(8.0)
0.14	(3.6)	0.34	(8.5)
0.12	(3.0)	0.36	(9.0)
0.10	(2.5)	0.38	(9.5)
0.08	(2.0)	0.40	(10.0)
0.06	(1.5)	0.42	(10.5)
0.04	(1.0)	0.44	(11.0)

**NOTE**

Ultrasonic measurement is to determine flange wear only. Use the ultrasonic only on fabricated idlers.

Do not use on General Duty Idlers

- 1 Flange width is 4.02 in. (102 mm)
- 2 New tread diameter is 25.00 in. (635 mm) or 25.47 in. (647 mm)
- 3 Wear Chart: 4426

**328, 330, 330 FM, 336, 340 - 8.50 in. (215.9 mm)**

**Carrier Rollers <sup>(1)</sup>  
Not for use on 532, 541, 1290, 1390, or TK732  
Genuine and General Duty**

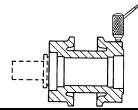
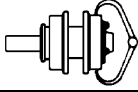

Caliper			Ultrasonic	
Inches	(mm)	% Worn	Inches	(mm)
6.30	(160.0)	0	1.62	(41.1)
6.26	(159.0)	4	1.60	(40.6)
6.22	(158.0)	8	1.58	(40.1)
6.18	(157.0)	12	1.56	(39.6)
6.14	(156.0)	16	1.54	(39.1)
6.10	(155.0)	20	1.52	(38.6)
6.06	(154.0)	24	1.50	(38.1)
6.02	(153.0)	28	1.48	(37.6)
5.98	(152.0)	32	1.46	(37.1)
5.94	(151.0)	36	1.44	(36.6)
5.90	(150.0)	40	1.42	(36.1)
5.86	(149.0)	44	1.40	(35.6)
5.82	(148.0)	48	1.38	(35.1)
5.78	(147.0)	52	1.36	(34.5)
5.74	(146.0)	56	1.34	(34.0)
5.70	(145.0)	60	1.32	(33.5)
5.66	(144.0)	64	1.30	(33.0)
5.62	(142.5)	68	1.28	(32.5)
5.58	(141.5)	72	1.26	(32.0)
5.54	(140.5)	76	1.24	(31.5)
5.50	(139.5)	80	1.22	(31.0)
5.46	(138.5)	84	1.20	(30.5)
5.42	(137.5)	88	1.18	(30.0)
5.38	(136.5)	92	1.16	(29.5)
5.34	(135.5)	94	1.14	(29.0)
5.30	(134.5)	96	1.12	(28.4)
5.26	(133.5)	98	1.10	(27.9)
5.22	(132.5)	100	1.08	(27.4)
5.18	(131.5)	102	1.06	(26.9)
5.14	(130.5)	104	1.04	(26.4)
5.10	(129.5)	106	1.02	(25.9)
5.06	(128.5)	108	1.00	(25.4)
5.02	(127.5)	110	0.98	(24.9)
4.98	(126.5)	112	0.96	(24.4)
4.94	(125.5)	114	0.94	(23.9)
4.90	(124.5)	116	0.92	(23.4)
4.86	(123.5)	118	0.90	(22.9)
4.82	(122.5)	120	0.88	(22.4)

**NOTE:** For 532, 541, 1290, 1390, & TK732, use Track Roller wear chart.

1 Wear Chart: 4722



**328, 330, 330 FM, 336, 340, 532, 541, 1290, 1390, TK732 - 8.50 in. (215.9 mm)**

**Track Rollers <sup>(1) (2)</sup>  
Genuine and General Duty**

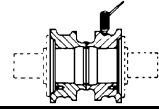
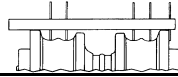
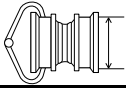

Caliper		% Worn	Depth Gauge		Ultrasonic	
Inches	(mm)		Inches	(mm)	Inches	(mm)
7.08	(180.0)	0	0.73	(18.5)	1.92	(48.8)
7.05	(179.0)	5	0.75	(19.0)	1.91	(48.4)
7.02	(178.5)	10	0.76	(19.5)	1.89	(48.0)
6.99	(177.5)	15	0.78	(19.5)	1.88	(47.6)
6.96	(177.0)	20	0.79	(20.0)	1.86	(47.2)
6.93	(176.0)	25	0.81	(20.5)	1.85	(46.9)
6.90	(175.5)	30	0.82	(21.0)	1.83	(46.5)
6.87	(174.5)	35	0.84	(21.0)	1.82	(46.1)
6.84	(173.5)	40	0.85	(21.5)	1.80	(45.7)
6.81	(173.0)	44	0.87	(22.0)	1.79	(45.3)
6.78	(172.0)	48	0.88	(22.5)	1.77	(45.0)
6.75	(171.5)	52	0.90	(22.5)	1.76	(44.6)
6.72	(170.5)	56	0.91	(23.0)	1.74	(44.2)
6.69	(170.0)	60	0.93	(23.5)	1.73	(43.8)
6.66	(169.0)	64	0.94	(24.0)	1.71	(43.4)
6.63	(168.5)	68	0.96	(24.5)	1.70	(43.1)
6.60	(167.5)	72	0.97	(24.5)	1.68	(42.7)
6.57	(167.0)	76	0.99	(25.0)	1.67	(42.3)
6.54	(166.0)	80	1.00	(25.5)	1.65	(41.9)
6.51	(165.5)	84	1.02	(26.0)	1.64	(41.5)
6.48	(164.5)	88	1.03	(26.0)	1.62	(41.1)
6.45	(164.0)	92	1.05	(26.5)	1.61	(40.8)
6.42	(163.0)	96	1.06	(27.0)	1.59	(40.4)
6.39	(162.5)	100	1.08	(27.5)	1.58	(40.0)
6.36	(161.5)	104	1.09	(27.5)	1.56	(39.6)
6.33	(161.0)	108	1.11	(28.0)	1.55	(39.2)
6.30	(160.0)	112	1.12	(28.5)	1.53	(38.9)
6.27	(159.5)	116	1.14	(29.0)	1.52	(38.5)
6.24	(158.5)	120	1.15	(29.0)	1.50	(38.1)

1 Flange diameter is 8.54 in. (217 mm)

2 Wear Chart: 5333

# 325 FM, 330 FM, 345, 349, 551, 552, 568, TK751, TK752 - 8.50 in. (215.9 mm)

Track Links <sup>(1)</sup>  
 Sealed Track, Grease Lubricated Track, PPR2 Track  
 150-4748 & 49, 130-5333 & 34, 209-6383 & 84  
 255-2364 & 65, 305-9361 & 62, 305-9363 & 64  
 390-9143 & 44

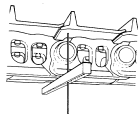

Depth Gauge			Ultrasonic	
Inches	(mm)	% Worn	Inches	(mm)
5.08	(129.0)	0	1.35	(34.3)
5.06	(128.5)	5	1.33	(33.8)
5.04	(128.0)	10	1.31	(33.3)
5.02	(127.5)	15	1.29	(32.8)
5.00	(127.0)	20	1.27	(32.3)
4.98	(126.5)	25	1.25	(31.8)
4.96	(126.0)	30	1.23	(31.2)
4.94	(125.5)	35	1.21	(30.7)
4.92	(125.0)	40	1.19	(30.2)
4.90	(124.5)	45	1.17	(29.7)
4.88	(124.0)	50	1.15	(29.2)
4.86	(123.5)	55	1.13	(28.7)
4.84	(123.0)	60	1.11	(28.2)
4.82	(122.5)	65	1.09	(27.7)
4.80	(122.0)	70	1.07	(27.2)
4.78	(121.5)	75	1.05	(26.7)
4.76	(121.0)	80	1.03	(26.2)
4.74	(120.5)	85	1.01	(25.7)
4.72	(120.0)	90	0.99	(25.1)
4.70	(119.5)	94	0.97	(24.6)
4.68	(119.0)	97	0.95	(24.1)
4.66	(118.5)	100	0.93	(23.6)
4.64	(118.0)	103	0.91	(23.1)
4.62	(117.5)	106	0.89	(22.6)
4.60	(117.0)	109	0.87	(22.1)
4.58	(116.5)	112	0.85	(21.6)
4.56	(116.0)	115	0.83	(21.1)
4.54	(115.5)	118	0.81	(20.6)
4.52	(115.0)	121	0.79	(20.1)

**Pins and Bushings <sup>(1)</sup>  
Internal Wear  
Sealed Track  
Grease Lubricated Track  
PPR2 Track**

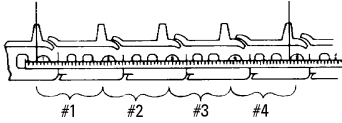

<b>Inches</b>	<b>(mm)</b>	<b>% Worn</b>
34.05	(865.0)	0
34.10	(866.0)	10
34.15	(867.5)	20
34.20	(868.5)	30
34.25	(870.0)	40
34.30	(871.0)	50
34.35	(872.5)	60
34.40	(874.0)	70
34.45	(875.0)	80
34.50	(876.5)	90
34.55	(877.5)	100
34.60	(879.0)	105
34.65	(880.0)	110
34.70	(881.5)	115
34.75	(882.5)	120

1 Wear Chart: 420

**325D FM, 330 FM, 345, 349, 551, 552, 568, TK751, TK752 - 8.50 in. (215.9 mm)**

**Bushings <sup>(1)</sup>  
External Wear  
Grease Lubricated Track  
PPR2 Track**

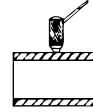
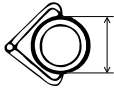

**Caliper**

**Ultrasonic**

Inches	(mm)	% Worn	Inches	(mm)
2.89	(73.4)	0	0.48	(12.2)
2.88	(73.2)	9	0.47	(11.9)
2.87	(72.9)	18	0.46	(11.7)
2.86	(72.6)	24	0.45	(11.4)
2.85	(72.4)	28	0.44	(11.2)
2.84	(72.1)	32	0.43	(10.9)
2.83	(71.9)	36	0.42	(10.7)
2.82	(71.6)	40	0.41	(10.4)
2.81	(71.4)	44	0.40	(10.2)
2.80	(71.1)	48	0.39	(9.9)
2.79	(70.9)	52	0.38	(9.7)
2.78	(70.6)	56	0.37	(9.4)
2.77	(70.4)	60	0.36	(9.1)
2.76	(70.1)	64	0.35	(8.9)
2.75	(69.9)	68	0.34	(8.6)
2.74	(69.6)	72	0.33	(8.4)
2.73	(69.3)	76	0.32	(8.1)
2.72	(69.1)	80	0.31	(7.9)
2.71	(68.8)	84	0.30	(7.6)
2.70	(68.6)	88	0.29	(7.4)
2.69	(68.3)	92	0.28	(7.1)
2.68	(68.1)	96	0.27	(6.9)
2.67	(67.8)	100	0.26	(6.6)
2.66	(67.6)	104	0.25	(6.3)
2.65	(67.3)	108	0.24	(6.1)
2.64	(67.1)	112	0.23	(5.8)
2.63	(66.8)	116	0.22	(5.6)
2.62	(66.5)	120	0.21	(5.3)

**NOTE**

Wear chart has been revised to increase the allowable wear (100% worn) from 2.74 in. (69.6 mm) to 2.67 in. (67.8 mm)

**Bushings <sup>(1)</sup>  
Sealed Track**

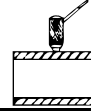
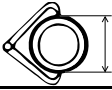

**Caliper**

**Ultrasonic**

<b>Caliper</b>		<b>% Worn</b>	<b>Ultrasonic</b>	
<b>Inches</b>	<b>(mm)</b>		<b>Inches</b>	<b>(mm)</b>
2.83	(71.9)	0	0.46	(11.7)
2.82	(71.6)	9	0.45	(11.4)
2.81	(71.4)	18	0.44	(11.2)
2.80	(71.1)	27	0.43	(10.9)
2.79	(70.9)	36	0.42	(10.7)
2.78	(70.6)	45	0.41	(10.4)
2.77	(70.4)	54	0.40	(10.2)
2.76	(70.1)	63	0.39	(9.9)
2.75	(69.9)	72	0.38	(9.7)
2.74	(69.6)	81	0.37	(9.4)
2.73	(69.3)	88	0.36	(9.1)
2.72	(69.1)	92	0.35	(8.9)
2.71	(68.8)	96	0.34	(8.6)
2.70	(68.6)	100	0.33	(8.4)
2.69	(68.3)	104	0.32	(8.1)
2.68	(68.1)	108	0.31	(7.9)
2.67	(67.8)	112	0.30	(7.6)
2.66	(67.6)	116	0.29	(7.4)
2.65	(67.3)	120	0.28	(7.1)

**325D FM, 330 FM, 345, 349, 551, 552, 568, TK751, TK752 - 8.50 in. (215.9 mm)**

**Track Shoes <sup>(1)</sup>  
Extreme Service**

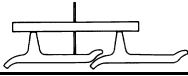

Depth Gauge			Ultrasonic	
Inches	(mm)	% Worn	Inches	(mm)
2.80	(71.0)	0	3.50	(88.9)
2.70	(68.5)	8	3.40	(86.4)
2.60	(66.0)	16	3.30	(83.8)
2.50	(63.5)	24	3.20	(81.3)
2.40	(61.0)	32	3.10	(78.7)
2.30	(58.5)	40	3.00	(76.2)
2.20	(56.0)	48	2.90	(73.7)
2.10	(53.5)	56	2.80	(71.1)
2.00	(51.0)	64	2.70	(68.6)
1.90	(48.5)	72	2.60	(66.0)
1.80	(45.5)	79	2.50	(63.5)
1.70	(43.0)	86	2.40	(61.0)
1.60	(40.5)	93	2.30	(58.4)
1.50	(38.0)	100	2.20	(55.9)
1.40	(35.5)	107	2.10	(53.3)
1.30	(33.0)	114	2.00	(50.8)
1.20	(30.5)	121	1.90	(48.3)

1 Wear Chart: 1320

**325D FM, 330 FM, 345, 349, 551, 552, 568, TK751, TK752 - 8.50 in. (215.9 mm)**

**Track Shoes <sup>(1)</sup>  
Double Grouser**

.59 in. (15 mm)

1.42 in. (36 mm)

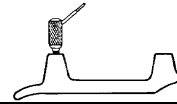
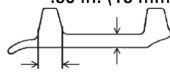
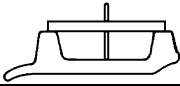

**Depth Gauge**

**Ultrasonic**

<b>Inches</b>	<b>(mm)</b>	<b>% Worn</b>	<b>Inches</b>	<b>(mm)</b>
1.95	(49.5)	0	2.54	(64.5)
1.85	(47.0)	10	2.44	(62.0)
1.75	(44.5)	20	2.34	(59.4)
1.65	(42.0)	30	2.24	(56.9)
1.55	(39.5)	40	2.14	(54.3)
1.45	(37.0)	50	2.04	(51.8)
1.35	(34.0)	60	1.94	(49.3)
1.25	(31.5)	70	1.84	(46.7)
1.15	(29.0)	80	1.74	(44.2)
1.05	(26.5)	85	1.64	(41.6)
0.95	(24.0)	90	1.54	(39.1)
0.85	(21.5)	95	1.44	(36.6)
0.75	(19.0)	100	1.34	(34.0)
0.65	(16.5)	105	1.24	(31.5)
0.55	(14.0)	110	1.14	(28.9)
0.45	(11.5)	115	1.04	(26.4)
0.35	(9.0)	120	0.94	(23.9)

**325D FM, 330 FM, 345, 349, 551, 552, 568, TK751, TK752 - 8.50 in. (215.9 mm)**

**Track Shoes <sup>(1)</sup>  
Triple Grouser**

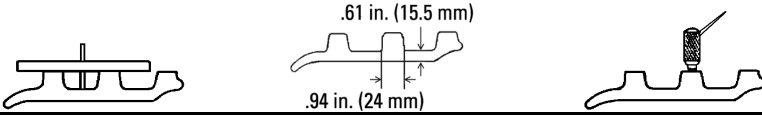

Depth Gauge			Ultrasonic	
Inches	(mm)	% Worn	Inches	(mm)
1.35	(34.5)	0	1.95	(49.5)
1.30	(33.0)	6	1.90	(48.2)
1.25	(32.0)	12	1.85	(47.0)
1.20	(30.5)	18	1.80	(45.7)
1.15	(29.0)	24	1.75	(44.4)
1.10	(28.0)	30	1.70	(43.2)
1.05	(26.5)	36	1.65	(41.9)
1.00	(25.5)	42	1.60	(40.6)
0.95	(24.0)	48	1.55	(39.3)
0.90	(23.0)	54	1.50	(38.1)
0.85	(21.5)	60	1.45	(36.8)
0.80	(20.5)	66	1.40	(35.5)
0.75	(19.0)	72	1.35	(34.3)
0.70	(18.0)	78	1.30	(33.0)
0.65	(16.5)	84	1.25	(31.7)
0.60	(15.0)	90	1.20	(30.5)
0.55	(14.0)	95	1.15	(29.2)
0.50	(12.5)	100	1.10	(27.9)
0.45	(11.5)	105	1.05	(26.6)
0.40	(10.0)	110	1.00	(25.4)
0.35	(9.0)	115	0.95	(24.1)
0.30	(7.5)	120	0.90	(22.8)



Idlers <sup>(1)</sup> <sup>(2)</sup> <sup>(3)</sup>  
**Cast Idler**  
**278-7281**

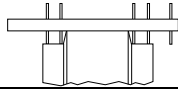

**Depth Gauge**

Inches	(mm)	% Worn
0.78	(20.0)	0
0.80	(20.5)	5
0.82	(21.0)	10
0.84	(21.5)	15
0.86	(22.0)	20
0.88	(22.5)	25
0.90	(23.0)	30
0.92	(23.5)	35
0.94	(24.0)	40
0.96	(24.5)	45
0.98	(25.0)	50
1.00	(25.5)	55
1.02	(26.0)	60
1.04	(26.5)	65
1.06	(27.0)	70
1.08	(27.5)	75
1.10	(28.0)	80
1.12	(28.5)	85
1.14	(29.0)	88
1.16	(29.5)	91
1.18	(30.0)	94
1.20	(30.5)	97
1.22	(31.0)	100
1.24	(31.5)	103
1.26	(32.0)	106
1.28	(32.5)	109
1.30	(33.0)	112
1.32	(33.5)	115
1.34	(34.0)	118
1.36	(34.5)	121

- 1 Flange width is 4.02 in. (102 mm)
- 2 New tread diameter is 24.61 in. (635 mm)
- 3 Wear Chart: 4432

# 325D FM, 330 FM, 345, 349, 551, 552, 568, TK751, TK752 - 8.50 in. (215.9 mm)

## Idlers <sup>(1)</sup> <sup>(2)</sup> <sup>(3)</sup>

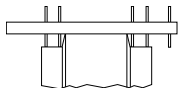

**Depth Gauge**

Inches	(mm)	% Worn
0.78	(20.0)	0
0.80	(20.5)	7
0.82	(21.0)	14
0.84	(21.5)	21
0.86	(22.0)	28
0.88	(22.5)	35
0.90	(23.0)	40
0.92	(23.5)	45
0.94	(24.0)	50
0.96	(24.5)	55
0.98	(25.0)	60
1.00	(25.5)	65
1.02	(26.0)	70
1.04	(26.5)	75
1.06	(27.0)	80
1.08	(27.5)	85
1.10	(28.0)	90
1.12	(28.5)	95
1.14	(29.0)	100
1.16	(29.5)	105
1.18	(30.0)	110
1.20	(30.5)	115
1.22	(31.0)	120

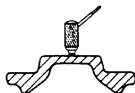

**Ultrasonic**

**Center Flange Wear**

Inches	(mm)	Inches	(mm)
0.48	(12.2)	0.00	(0.0)
0.46	(11.7)	0.02	(0.5)
0.44	(11.2)	0.04	(1.0)
0.42	(10.7)	0.06	(1.5)
0.40	(10.2)	0.08	(2.0)
0.38	(9.7)	0.10	(2.5)
0.36	(9.1)	0.12	(3.0)
0.34	(8.6)	0.14	(3.5)
0.32	(8.1)	0.16	(4.0)
0.30	(7.6)	0.18	(4.5)
0.28	(7.1)	0.20	(5.0)
0.26	(6.6)	0.22	(5.5)
0.24	(6.1)	0.24	(6.0)
0.22	(5.6)	0.26	(6.5)
0.20	(5.1)	0.28	(7.0)
0.18	(4.6)	0.30	(7.5)
0.16	(4.1)	0.32	(8.0)
0.14	(3.6)	0.34	(8.5)
0.12	(3.0)	0.36	(9.0)
0.10	(2.5)	0.38	(9.5)
0.08	(2.0)	0.40	(10.0)
0.06	(1.5)	0.42	(10.5)
0.04	(1.0)	0.44	(11.0)

### NOTE

Ultrasonic measurement is to determine flange wear only. Use the ultrasonic only on fabricated idlers.

- 1 Flange width is 4.02 in. (102 mm)
- 2 New tread diameter is 25.00 in. (635 mm)
- 3 Wear Chart: 4426

## 330 FM, 345, 349 - 8.50 in. (215.9 mm)

**Carrier Rollers <sup>(1)</sup>**  
**Not for use on 325D FM, 551, 552, 568, TK751, TK752**

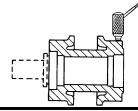
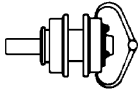

Caliper			Ultrasonic		
Inches	(mm)	% Worn	Inches	(mm)	
7.08	(180.0)	0	1.21	(30.7)	
7.04	(179.0)	8	1.19	(30.2)	
7.00	(178.0)	16	1.17	(29.7)	
6.96	(177.0)	24	1.15	(29.2)	
6.92	(176.0)	32	1.13	(28.7)	
6.88	(175.0)	40	1.11	(28.2)	
6.84	(173.5)	45	1.09	(27.7)	
6.80	(172.5)	50	1.07	(27.2)	
6.76	(171.5)	55	1.05	(26.7)	
6.72	(170.5)	60	1.03	(26.2)	
6.68	(169.5)	65	1.01	(25.7)	
6.64	(168.5)	70	0.99	(25.1)	
6.60	(167.5)	75	0.97	(24.6)	
6.56	(166.5)	80	0.95	(24.1)	
6.52	(165.5)	85	0.93	(23.6)	
6.48	(164.5)	90	0.91	(23.1)	
6.44	(163.5)	95	0.89	(22.6)	
6.40	(162.5)	100	0.87	(22.1)	
6.36	(161.5)	105	0.85	(21.6)	
6.32	(160.5)	110	0.83	(21.1)	
6.28	(159.5)	115	0.81	(20.6)	
6.24	(158.5)	120	0.79	(20.1)	

**NOTE**

For 325D FM, 551, 552, 568, TK751, TK752, use Track Roller wear chart [on, page 691](#).

# 325D FM, 330 FM, 345, 349 - 8.50 in. (215.9 mm)

## Track Rollers <sup>(1) (2)</sup> Not for use on 551, 552, 568, TK751, TK752

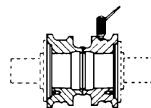
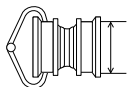

Caliper			Depth Gauge		Ultrasonic	
Inches	(mm)	% Worn	Inches	(mm)	Inches	(mm)
7.87	(200.0)	0	0.78	(20.0)	2.12	(53.8)
7.83	(199.0)	5	0.80	(20.5)	2.10	(53.3)
7.79	(198.0)	10	0.82	(21.0)	2.08	(52.8)
7.75	(197.0)	15	0.84	(21.5)	2.06	(52.3)
7.71	(196.0)	20	0.86	(22.0)	2.04	(51.8)
7.67	(195.0)	25	0.88	(22.5)	2.02	(51.3)
7.63	(194.0)	30	0.90	(23.0)	2.00	(50.8)
7.59	(193.0)	35	0.92	(23.5)	1.98	(50.3)
7.55	(192.0)	40	0.94	(24.0)	1.96	(49.8)
7.51	(191.0)	45	0.96	(24.5)	1.94	(49.3)
7.47	(189.5)	50	0.98	(25.0)	1.92	(48.8)
7.43	(188.5)	55	1.00	(25.5)	1.90	(48.3)
7.39	(187.5)	60	1.02	(26.0)	1.88	(47.8)
7.35	(186.5)	64	1.04	(26.5)	1.86	(47.2)
7.31	(185.5)	68	1.06	(27.0)	1.84	(46.7)
7.27	(184.5)	72	1.08	(27.5)	1.82	(46.2)
7.23	(183.5)	76	1.10	(28.0)	1.80	(45.7)
7.19	(182.5)	80	1.12	(28.5)	1.78	(45.2)
7.15	(181.5)	84	1.14	(29.0)	1.76	(44.7)
7.11	(180.5)	88	1.16	(29.5)	1.74	(44.2)
7.07	(179.5)	92	1.18	(30.0)	1.72	(43.7)
7.03	(178.5)	96	1.20	(30.5)	1.70	(43.2)
6.99	(177.5)	100	1.22	(31.0)	1.68	(42.7)
6.95	(176.5)	104	1.24	(31.5)	1.66	(42.2)
6.91	(175.5)	108	1.26	(32.0)	1.64	(41.7)
6.87	(174.5)	112	1.28	(32.5)	1.62	(41.1)
6.83	(173.5)	116	1.30	(33.0)	1.60	(40.6)
6.79	(172.5)	120	1.32	(33.5)	1.58	(40.1)

1 Flange diameter is 9.45 in. (240 mm)

2 Wear Chart: 5335

# 551, 552, 568, TK751, TK752 - 8.50 in. (215.9 mm)

## Track Rollers <sup>(1) (2)</sup> For use only on 551, 552, 568, TK751, TK752

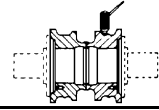
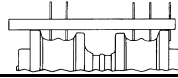
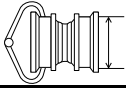

Caliper		% Worn	Depth Gauge		Ultrasonic	
Inches	(mm)		Inches	(mm)	Inches	(mm)
7.08	(180.0)	0	0.73	(18.5)	1.92	(48.8)
7.05	(179.0)	5	0.75	(19.0)	1.91	(48.4)
7.02	(178.5)	10	0.76	(19.5)	1.89	(48.0)
6.99	(177.5)	15	0.78	(19.5)	1.88	(47.6)
6.96	(177.0)	20	0.79	(20.0)	1.86	(47.2)
6.93	(176.0)	25	0.81	(20.5)	1.85	(46.9)
6.90	(175.5)	30	0.82	(21.0)	1.83	(46.5)
6.87	(174.5)	35	0.84	(21.0)	1.82	(46.1)
6.84	(173.5)	40	0.85	(21.5)	1.80	(45.7)
6.81	(173.0)	44	0.87	(22.0)	1.79	(45.3)
6.78	(172.0)	48	0.88	(22.5)	1.77	(45.0)
6.75	(171.5)	52	0.90	(22.5)	1.76	(44.6)
6.72	(170.5)	56	0.91	(23.0)	1.74	(44.2)
6.69	(170.0)	60	0.93	(23.5)	1.73	(43.8)
6.66	(169.0)	64	0.94	(24.0)	1.71	(43.4)
6.63	(168.5)	68	0.96	(24.5)	1.70	(43.1)
6.60	(167.5)	72	0.97	(24.5)	1.68	(42.7)
6.57	(167.0)	76	0.99	(25.0)	1.67	(42.3)
6.54	(166.0)	80	1.00	(25.5)	1.65	(41.9)
6.51	(165.5)	84	1.02	(26.0)	1.64	(41.5)
6.48	(164.5)	88	1.03	(26.0)	1.62	(41.1)
6.45	(164.0)	92	1.05	(26.5)	1.61	(40.8)
6.42	(163.0)	96	1.06	(27.0)	1.59	(40.4)
6.39	(162.5)	100	1.08	(27.5)	1.58	(40.0)
6.36	(161.5)	104	1.09	(27.5)	1.56	(39.6)
6.33	(161.0)	108	1.11	(28.0)	1.55	(39.2)
6.30	(160.0)	112	1.12	(28.5)	1.53	(38.9)
6.27	(159.5)	116	1.14	(29.0)	1.52	(38.5)
6.24	(158.5)	120	1.15	(29.0)	1.50	(38.1)

1 Wear Chart: 5333

2 Flange diameter is 8.54 in. (217 mm)



Track Links <sup>(1)</sup>  
8E-6091 & 92  
217-7681 & 82

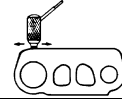
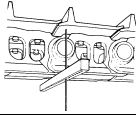

Depth Gauge			Ultrasonic	
Inches	(mm)	% Worn	Inches	(mm)
5.43	(138.0)	0	1.46	(37.1)
5.41	(137.5)	7	1.44	(36.6)
5.39	(137.0)	14	1.42	(36.1)
5.37	(136.5)	21	1.40	(35.6)
5.35	(136.0)	28	1.38	(35.1)
5.33	(135.5)	35	1.36	(34.5)
5.31	(135.0)	40	1.34	(34.0)
5.29	(134.5)	44	1.32	(33.5)
5.27	(134.0)	48	1.30	(33.0)
5.25	(133.5)	52	1.28	(32.5)
5.23	(133.0)	56	1.26	(32.0)
5.21	(132.5)	60	1.24	(31.5)
5.19	(132.0)	64	1.22	(31.0)
5.17	(131.5)	68	1.20	(30.5)
5.15	(131.0)	72	1.18	(30.0)
5.13	(130.5)	76	1.16	(29.5)
5.11	(130.0)	80	1.14	(29.0)
5.09	(129.5)	84	1.12	(28.4)
5.07	(129.0)	88	1.10	(27.9)
5.05	(128.5)	92	1.08	(27.4)
5.03	(128.0)	96	1.06	(26.9)
5.01	(127.5)	100	1.04	(26.4)
4.99	(126.5)	104	1.02	(25.9)
4.97	(126.0)	108	1.00	(25.4)
4.95	(125.5)	112	0.98	(24.9)
4.93	(125.0)	116	0.96	(24.4)
4.91	(124.5)	120	0.94	(23.9)

**345FM, 350 - 9.00 in. (228.6 mm)**

**Pins and Bushings <sup>(1)</sup>  
Internal Wear  
Sealed Track**

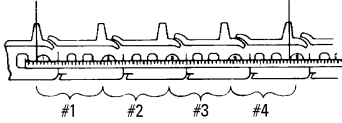

<b>Inches</b>	<b>(mm)</b>	<b>% Worn</b>
36.05	(915.5)	0
36.10	(917.0)	10
36.15	(918.0)	20
36.20	(919.5)	30
36.25	(920.5)	40
36.30	(922.0)	50
36.35	(923.5)	60
36.40	(924.5)	70
36.45	(926.0)	80
36.50	(927.0)	90
36.55	(928.5)	100
36.60	(929.5)	105
36.65	(931.0)	110
36.70	(932.0)	115
36.75	(933.5)	120

1 Wear Chart: 440



**Bushings <sup>(1)</sup>  
External Wear  
Sealed Track**

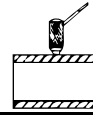

**Caliper**

**Ultrasonic**

Caliper		% Worn	Ultrasonic	
Inches	(mm)		Inches	(mm)
3.04	(77.2)	0	0.49	(12.4)
3.03	(77.0)	9	0.48	(12.2)
3.02	(76.7)	18	0.47	(11.9)
3.01	(76.5)	27	0.46	(11.7)
3.00	(76.2)	36	0.45	(11.4)
2.99	(75.9)	45	0.44	(11.2)
2.98	(75.7)	54	0.43	(10.9)
2.97	(75.4)	63	0.42	(10.7)
2.96	(75.2)	72	0.41	(10.4)
2.95	(74.9)	80	0.40	(10.2)
2.94	(74.7)	84	0.39	(9.9)
2.93	(74.4)	88	0.38	(9.7)
2.92	(74.2)	92	0.37	(9.4)
2.91	(73.9)	96	0.36	(9.1)
2.90	(73.7)	100	0.35	(8.9)
2.89	(73.4)	104	0.34	(8.6)
2.88	(73.2)	108	0.33	(8.4)
2.87	(72.9)	112	0.32	(8.1)
2.86	(72.6)	116	0.31	(7.9)
2.85	(72.4)	120	0.30	(7.6)

**345FM, 350 - 9.00 in. (228.6 mm)**

**Track Shoes <sup>(1)</sup>  
Double Grouser**

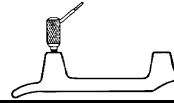
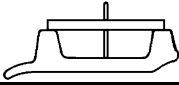
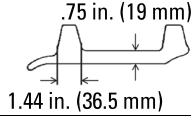

Depth Gauge			Ultrasonic	
Inches	(mm)	% Worn	Inches	(mm)
1.75	(44.5)	0	2.50	(63.5)
1.70	(43.0)	5	2.45	(62.2)
1.65	(42.0)	10	2.40	(61.0)
1.60	(40.5)	15	2.35	(59.7)
1.55	(39.5)	20	2.30	(58.4)
1.50	(38.0)	25	2.25	(57.2)
1.45	(37.0)	30	2.20	(55.9)
1.40	(35.5)	35	2.15	(54.6)
1.35	(34.5)	40	2.10	(53.3)
1.30	(33.0)	45	2.05	(52.1)
1.25	(32.0)	50	2.00	(50.8)
1.20	(30.5)	55	1.95	(49.5)
1.15	(29.0)	60	1.90	(48.3)
1.10	(28.0)	65	1.85	(47.0)
1.05	(26.5)	70	1.80	(45.7)
1.00	(25.5)	75	1.75	(44.5)
0.95	(24.0)	80	1.70	(43.2)
0.90	(23.0)	85	1.65	(41.9)
0.85	(21.5)	90	1.60	(40.6)
0.80	(20.5)	95	1.55	(39.4)
0.75	(19.0)	100	1.50	(38.1)
0.70	(18.0)	105	1.45	(36.8)
0.65	(16.5)	110	1.40	(35.6)
0.60	(15.0)	115	1.35	(34.3)
0.55	(14.0)	120	1.30	(33.0)

**Track Shoes <sup>(1)</sup>  
Triple Grouser**

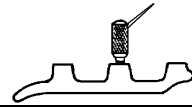
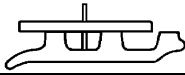
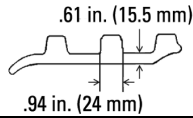

**Depth Gauge**

**Ultrasonic**

Inches	(mm)	% Worn	Inches	(mm)
1.35	(34.5)	0	1.95	(49.5)
1.30	(33.0)	6	1.90	(48.2)
1.25	(32.0)	12	1.85	(47.0)
1.20	(30.5)	18	1.80	(45.7)
1.15	(29.0)	24	1.75	(44.4)
1.10	(28.0)	30	1.70	(43.2)
1.05	(26.5)	36	1.65	(41.9)
1.00	(25.5)	42	1.60	(40.6)
0.95	(24.0)	48	1.55	(39.3)
0.90	(23.0)	54	1.50	(38.1)
0.85	(21.5)	60	1.45	(36.8)
0.80	(20.5)	66	1.40	(35.5)
0.75	(19.0)	72	1.35	(34.3)
0.70	(18.0)	78	1.30	(33.0)
0.65	(16.5)	84	1.25	(31.7)
0.60	(15.0)	90	1.20	(30.5)
0.55	(14.0)	95	1.15	(29.2)
0.50	(12.5)	100	1.10	(27.9)
0.45	(11.5)	105	1.05	(26.6)
0.40	(10.0)	110	1.00	(25.4)
0.35	(9.0)	115	0.95	(24.1)
0.30	(7.5)	120	0.90	(22.8)

# 345FM, 350 - 9.00 in. (228.6 mm)

## Idlers <sup>(1)</sup> <sup>(2)</sup> <sup>(3)</sup>

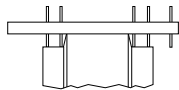

**Depth Gauge**

Inches	(mm)	% Worn
0.94	(24.0)	0
0.96	(24.5)	7
0.98	(25.0)	14
1.00	(25.5)	21
1.02	(26.0)	28
1.04	(26.5)	35
1.06	(27.0)	40
1.08	(27.5)	45
1.10	(28.0)	50
1.12	(28.5)	55
1.14	(29.0)	60
1.16	(29.5)	65
1.18	(30.0)	70
1.20	(30.5)	75
1.22	(31.0)	80
1.24	(31.5)	85
1.26	(32.0)	90
1.28	(32.5)	95
1.30	(33.0)	100
1.32	(33.5)	105
1.34	(34.0)	110
1.36	(34.5)	115
1.38	(35.0)	120

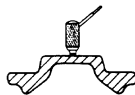

**Ultrasonic**

**Center Flange Wear**

Inches	(mm)	Inches	(mm)
0.48	(12.2)	0.00	(0.0)
0.46	(11.7)	0.02	(0.5)
0.44	(11.2)	0.04	(1.0)
0.42	(10.7)	0.06	(1.5)
0.40	(10.2)	0.08	(2.0)
0.38	(9.7)	0.10	(2.5)
0.36	(9.1)	0.12	(3.0)
0.34	(8.6)	0.14	(3.5)
0.32	(8.1)	0.16	(4.0)
0.30	(7.6)	0.18	(4.5)
0.28	(7.1)	0.20	(5.0)
0.26	(6.6)	0.22	(5.5)
0.24	(6.1)	0.24	(6.0)
0.22	(5.6)	0.26	(6.5)
0.20	(5.1)	0.28	(7.0)
0.18	(4.6)	0.30	(7.5)
0.16	(4.1)	0.32	(8.0)
0.14	(3.6)	0.34	(8.5)
0.12	(3.0)	0.36	(9.0)
0.10	(2.5)	0.38	(9.5)
0.08	(2.0)	0.40	(10.0)
0.06	(1.5)	0.42	(10.5)
0.04	(1.0)	0.44	(11.0)

### NOTE

Ultrasonic measurement is to determine flange wear only. Use the ultrasonic only on fabricated idlers.

- 1 Flange width is 4.75 in. (120.7 mm)
- 2 New tread diameter is 27.17 in. (690 mm)
- 3 Wear Chart: 4444

Carrier Rollers <sup>(1)</sup>

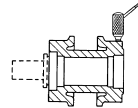
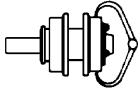

Caliper			Ultrasonic		
Inches	(mm)	% Worn	Inches	(mm)	
7.48	(190.0)	0	1.41	(35.8)	
7.44	(189.0)	8	1.39	(35.3)	
7.40	(188.0)	16	1.37	(34.8)	
7.36	(187.0)	24	1.35	(34.3)	
7.32	(186.0)	28	1.33	(33.8)	
7.28	(185.0)	32	1.31	(33.3)	
7.24	(184.0)	36	1.29	(32.8)	
7.20	(183.0)	40	1.27	(32.3)	
7.16	(182.0)	44	1.25	(31.8)	
7.12	(181.0)	48	1.23	(31.2)	
7.08	(180.0)	52	1.21	(30.7)	
7.04	(179.0)	56	1.19	(30.2)	
7.00	(178.0)	60	1.17	(29.7)	
6.96	(177.0)	64	1.15	(29.2)	
6.92	(176.0)	68	1.13	(28.7)	
6.88	(175.0)	72	1.11	(28.2)	
6.84	(173.5)	76	1.09	(27.7)	
6.80	(172.5)	80	1.07	(27.2)	
6.76	(171.5)	84	1.05	(26.7)	
6.72	(170.5)	88	1.03	(26.2)	
6.68	(169.5)	92	1.01	(25.7)	
6.64	(168.5)	96	0.99	(25.1)	
6.60	(167.5)	100	0.97	(24.6)	
6.56	(166.5)	104	0.95	(24.1)	
6.52	(165.5)	108	0.93	(23.6)	
6.48	(164.5)	112	0.91	(23.1)	
6.44	(163.5)	116	0.89	(22.6)	
6.40	(162.5)	120	0.87	(22.1)	

# 345FM, 350 - 9.00 in. (228.6 mm)

## Track Rollers <sup>(1)</sup> <sup>(2)</sup>

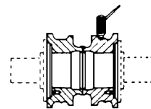
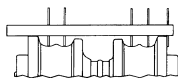

Caliper			Depth Gauge		Ultrasonic	
Inches	(mm)	% Worn	Inches	(mm)	Inches	(mm)
8.26	(219.0)	0	0.78	(20.0)	2.32	(58.9)
8.22	(209.0)	6	0.80	(20.5)	2.30	(58.4)
8.18	(208.0)	12	0.82	(21.0)	2.28	(57.9)
8.14	(207.0)	18	0.84	(21.5)	2.26	(57.4)
8.10	(205.5)	24	0.86	(22.0)	2.24	(56.9)
8.06	(204.5)	30	0.88	(22.5)	2.22	(56.4)
8.02	(203.5)	36	0.90	(23.0)	2.20	(55.9)
7.98	(202.5)	42	0.92	(23.5)	2.18	(55.4)
7.94	(201.5)	48	0.94	(24.0)	2.16	(54.9)
7.90	(200.5)	52	0.96	(24.5)	2.14	(54.4)
7.86	(199.5)	56	0.98	(25.0)	2.12	(53.8)
7.82	(198.5)	60	1.00	(25.5)	2.10	(53.3)
7.78	(197.5)	64	1.02	(26.0)	2.08	(52.8)
7.74	(196.5)	68	1.04	(26.5)	2.06	(52.3)
7.70	(195.5)	72	1.06	(27.0)	2.04	(51.8)
7.66	(194.5)	76	1.08	(27.5)	2.02	(51.3)
7.62	(193.5)	80	1.10	(28.0)	2.00	(50.8)
7.58	(192.5)	84	1.12	(28.5)	1.98	(50.3)
7.54	(191.5)	88	1.14	(29.0)	1.96	(49.8)
7.50	(190.5)	92	1.16	(29.5)	1.94	(49.3)
7.46	(189.5)	96	1.18	(30.0)	1.92	(48.8)
7.42	(188.5)	100	1.20	(30.5)	1.90	(48.3)
7.38	(187.5)	104	1.22	(31.0)	1.88	(47.8)
7.34	(186.5)	108	1.24	(31.5)	1.86	(47.2)
7.30	(185.5)	112	1.26	(32.0)	1.84	(46.7)
7.26	(184.5)	116	1.28	(32.5)	1.82	(46.2)
7.22	(183.5)	120	1.30	(33.0)	1.80	(45.7)

1 Flange diameter is 9.84 in. (250 mm)

2 Wear Chart: 5345

**Track Links <sup>(1)</sup>**  
**Sealed Track, Grease Lubricated Track, PPR2 Track**  
**296-4361 & 62**  
**142-1803 & 04**

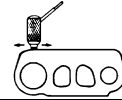
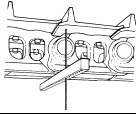

Depth Gauge			Ultrasonic	
Inches	(mm)	% Worn	Inches	(mm)
5.88	(149.5)	0	1.33	(33.8)
5.86	(149.0)	6	1.31	(33.3)
5.84	(148.5)	12	1.29	(32.8)
5.82	(148.0)	18	1.27	(32.3)
5.80	(147.5)	24	1.25	(31.8)
5.78	(147.0)	30	1.23	(31.2)
5.76	(146.5)	36	1.21	(30.7)
5.74	(146.0)	42	1.19	(30.2)
5.72	(145.5)	48	1.17	(29.7)
5.70	(145.0)	54	1.15	(29.2)
5.68	(144.5)	60	1.13	(28.7)
5.66	(144.0)	66	1.11	(28.2)
5.64	(143.5)	72	1.09	(27.7)
5.62	(142.5)	76	1.07	(27.2)
5.60	(142.0)	80	1.05	(26.7)
5.58	(141.5)	84	1.03	(26.2)
5.56	(141.0)	88	1.01	(25.7)
5.54	(140.5)	92	0.99	(25.1)
5.52	(140.0)	96	0.97	(24.6)
5.50	(139.5)	100	0.95	(24.1)
5.48	(139.0)	104	0.93	(23.6)
5.46	(138.5)	108	0.91	(23.1)
5.44	(138.0)	112	0.89	(22.6)
5.42	(137.5)	116	0.87	(22.1)
5.40	(137.0)	120	0.85	(21.6)

# 375, 385, 390, 5080, 5090 - 10.25 in. (260.4 mm)

Track Links <sup>(1)</sup>  
 Sealed Track, Grease Lubricated Track, PPR2 Track  
 296-4359 & 60  
 174-0217 & 18  
 6Y-6721 & 22

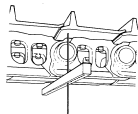

Depth Gauge			Ultrasonic	
Inches	(mm)	% Worn	Inches	(mm)
6.12	(155.5)	0	1.57	(39.9)
6.10	(155.0)	6	1.55	(39.4)
6.08	(154.5)	12	1.53	(38.9)
6.06	(154.0)	18	1.51	(38.4)
6.04	(153.5)	24	1.49	(37.8)
6.02	(153.0)	30	1.47	(37.3)
6.00	(152.5)	36	1.45	(36.8)
5.98	(152.0)	42	1.43	(36.3)
5.96	(151.5)	46	1.41	(35.8)
5.94	(151.0)	49	1.39	(35.3)
5.92	(150.5)	52	1.37	(34.8)
5.90	(150.0)	55	1.35	(34.3)
5.88	(149.5)	58	1.33	(33.8)
5.86	(149.0)	61	1.31	(33.3)
5.84	(148.5)	64	1.29	(32.8)
5.82	(148.0)	67	1.27	(32.3)
5.80	(147.5)	70	1.25	(31.8)
5.78	(147.0)	73	1.23	(31.2)
5.76	(146.5)	76	1.21	(30.7)
5.74	(146.0)	79	1.19	(30.2)
5.72	(145.5)	82	1.17	(29.7)
5.70	(145.0)	85	1.15	(29.2)
5.68	(144.5)	88	1.13	(28.7)
5.66	(144.0)	91	1.11	(28.2)
5.64	(143.5)	94	1.09	(27.7)
5.62	(142.5)	97	1.07	(27.2)
5.60	(142.0)	100	1.05	(26.7)
5.58	(141.5)	103	1.03	(26.2)
5.56	(141.0)	106	1.01	(25.7)
5.54	(140.5)	109	0.99	(25.1)
5.52	(140.0)	112	0.97	(24.6)
5.50	(139.5)	115	0.95	(24.1)
5.48	(139.0)	118	0.93	(23.6)
5.46	(138.5)	121	0.91	(23.1)



Pins and Bushings <sup>(1)</sup>  
 Internal Wear  
 Sealed Track  
 Grease Lubricated Track  
 PPR2 Track

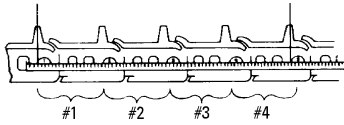

Inches	(mm)	% Worn
41.05	(1042.5)	0
41.10	(1044.0)	10
41.15	(1045.0)	20
41.20	(1046.5)	30
41.25	(1048.0)	40
41.30	(1049.0)	50
41.35	(1050.5)	60
41.40	(1051.5)	70
41.45	(1053.0)	80
41.50	(1054.0)	90
41.55	(1055.5)	100
41.60	(1056.5)	105
41.65	(1058.0)	110
41.70	(1059.0)	115
41.75	(1060.5)	120

**365, 374, 385, 390, 5090 - 10.25 in. (260.4 mm)**

**Bushings <sup>(1)</sup>  
External Wear  
Grease Lubricated Track  
PPR2 Track  
(not for use on 365, 375 or 5080 Sealed Track)**



**Caliper**

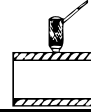

**Ultrasonic**

<b>Inches</b>	<b>(mm)</b>	<b>% Worn</b>	<b>Inches</b>	<b>(mm)</b>
3.47	(88.1)	0	0.59	(15.0)
3.46	(87.9)	7	0.58	(14.7)
3.45	(87.6)	14	0.57	(14.5)
3.44	(87.4)	21	0.56	(14.2)
3.43	(87.1)	28	0.55	(14.0)
3.42	(86.9)	35	0.54	(13.7)
3.41	(86.6)	42	0.53	(13.5)
3.40	(86.4)	49	0.52	(13.2)
3.39	(86.1)	56	0.51	(13.0)
3.38	(85.9)	63	0.50	(12.7)
3.37	(85.6)	70	0.49	(12.4)
3.36	(85.3)	77	0.48	(12.2)
3.35	(85.1)	84	0.47	(11.9)
3.34	(84.8)	88	0.46	(11.7)
3.33	(84.6)	91	0.45	(11.4)
3.32	(84.3)	94	0.44	(11.2)
3.31	(84.1)	97	0.43	(10.9)
3.30	(83.8)	100	0.42	(10.7)
3.29	(83.6)	103	0.41	(10.4)
3.28	(83.3)	106	0.40	(10.2)
3.27	(83.1)	109	0.39	(9.9)
3.26	(82.8)	112	0.38	(9.7)
3.25	(82.6)	115	0.37	(9.4)
3.24	(82.3)	118	0.36	(9.1)
3.23	(82.0)	121	0.35	(8.9)

**Bushings <sup>(1)</sup>  
External Wear  
Sealed Track  
(for use on 365, 375 and 5080)**

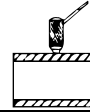

Caliper			Ultrasonic	
Inches	(mm)	% Worn	Inches	(mm)
3.39	(86.1)	0	0.55	(14.0)
3.38	(85.9)	9	0.54	(13.7)
3.37	(85.6)	18	0.53	(13.5)
3.36	(85.3)	27	0.52	(13.2)
3.35	(85.1)	36	0.51	(13.0)
3.34	(84.8)	45	0.50	(12.7)
3.33	(84.6)	54	0.49	(12.4)
3.32	(84.3)	63	0.48	(12.2)
3.31	(84.1)	72	0.47	(11.9)
3.30	(83.8)	81	0.46	(11.7)
3.29	(83.6)	88	0.45	(11.4)
3.28	(83.3)	92	0.44	(11.2)
3.27	(83.1)	96	0.43	(10.9)
3.26	(82.8)	100	0.42	(10.7)
3.25	(82.6)	104	0.41	(10.4)
3.24	(82.3)	108	0.40	(10.2)
3.23	(82.0)	112	0.39	(9.9)
3.22	(81.8)	116	0.38	(9.7)
3.21	(81.5)	120	0.37	(9.4)

**365, 374, 375, 385, 390, 5080, 5090 - 10.25 in. (260.4 mm)**

**Track Shoes <sup>(1)</sup>  
Extreme Service**

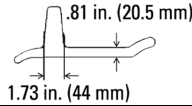
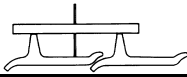

Depth Gauge			Ultrasonic	
Inches	(mm)	% Worn	Inches	(mm)
3.70	(94.0)	0	4.50	(114.3)
3.60	(91.5)	5	4.40	(111.8)
3.50	(89.0)	10	4.30	(109.2)
3.40	(86.5)	15	4.20	(106.7)
3.30	(84.0)	20	4.10	(104.1)
3.20	(81.5)	25	4.00	(101.6)
3.10	(78.5)	30	3.90	(99.1)
3.00	(76.0)	35	3.80	(96.5)
2.90	(73.5)	40	3.70	(94.0)
2.80	(71.0)	45	3.60	(91.4)
2.70	(68.5)	50	3.50	(88.9)
2.60	(66.0)	55	3.40	(86.4)
2.50	(63.5)	60	3.30	(83.8)
2.40	(61.0)	64	3.20	(81.3)
2.30	(58.5)	68	3.10	(78.7)
2.20	(56.0)	72	3.00	(76.2)
2.10	(53.5)	76	2.90	(73.7)
2.00	(51.0)	80	2.80	(71.1)
1.90	(48.5)	84	2.70	(68.6)
1.80	(45.5)	88	2.60	(66.0)
1.70	(43.0)	92	2.50	(63.5)
1.60	(40.5)	96	2.40	(61.0)
1.50	(38.0)	100	2.30	(58.4)
1.40	(35.5)	104	2.20	(55.9)
1.30	(33.0)	108	2.10	(53.3)
1.20	(30.5)	112	2.00	(50.8)
1.10	(28.0)	116	1.90	(48.3)
1.00	(25.5)	120	1.80	(45.7)

**365, 374, 375, 385, 390, 5080, 5090 - 10.25 in. (260.4 mm)**

**Track Shoes <sup>(1)</sup>  
Double Grouser**

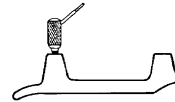
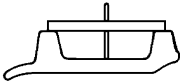
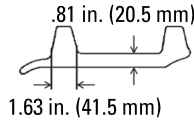

**Depth Gauge**

**Ultrasonic**

Inches	(mm)	% Worn	Inches	(mm)
1.90	(48.5)	0	2.70	(68.6)
1.85	(47.0)	5	2.65	(67.3)
1.80	(45.5)	10	2.60	(66.0)
1.75	(44.5)	15	2.55	(64.8)
1.70	(43.0)	20	2.50	(63.5)
1.65	(42.0)	25	2.45	(62.2)
1.60	(40.5)	30	2.40	(61.0)
1.55	(39.5)	35	2.35	(59.7)
1.50	(38.0)	40	2.30	(58.4)
1.45	(37.0)	45	2.25	(57.2)
1.40	(35.5)	50	2.20	(55.9)
1.35	(34.5)	55	2.15	(54.6)
1.30	(33.0)	60	2.10	(53.3)
1.25	(32.0)	65	2.05	(52.1)
1.20	(30.5)	70	2.00	(50.8)
1.15	(29.0)	75	1.95	(49.5)
1.10	(28.0)	80	1.90	(48.3)
1.05	(26.5)	84	1.85	(47.0)
1.00	(25.5)	88	1.80	(45.7)
0.95	(24.0)	92	1.75	(44.5)
0.90	(23.0)	96	1.70	(43.2)
0.85	(21.5)	100	1.65	(41.9)
0.80	(20.5)	104	1.60	(40.6)
0.75	(19.0)	108	1.55	(39.4)
0.70	(18.0)	112	1.50	(38.1)
0.65	(16.5)	116	1.45	(36.8)
0.60	(15.0)	120	1.40	(35.6)

# 365, 374, 385, 390 - 10.25 in. (260.4 mm)

Idlers <sup>(1)</sup> <sup>(2)</sup> <sup>(3)</sup>  
**Cast Idler**  
**278-7285**

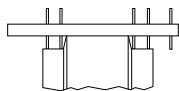

**Depth Gauge**

Inches	(mm)	% Worn
0.88	(22.5)	0
0.90	(23.0)	4
0.92	(23.5)	8
0.94	(24.0)	12
0.96	(24.5)	16
0.98	(25.0)	20
1.00	(25.5)	24
1.02	(26.0)	28
1.04	(26.5)	32
1.06	(27.0)	36
1.08	(27.5)	40
1.10	(28.0)	44
1.12	(28.5)	48
1.14	(29.0)	52
1.16	(29.5)	56
1.18	(30.0)	60
1.20	(30.5)	64
1.22	(31.0)	67
1.24	(31.5)	70
1.26	(32.0)	73
1.28	(32.5)	76
1.30	(33.0)	79
1.32	(33.5)	82
1.34	(34.0)	85
1.36	(34.5)	88
1.38	(35.0)	91
1.40	(35.5)	94
1.42	(36.0)	97
1.44	(36.5)	100
1.46	(37.0)	103
1.48	(37.5)	106
1.50	(38.0)	109
1.52	(38.5)	112
1.54	(39.0)	115
1.56	(39.5)	118
1.58	(40.0)	121

- 1 Flange width is 5.09 in. (129.3 mm)
- 2 New tread diameter is 30.31 in. (770 mm)
- 3 Wear Chart: 4489

Idlers <sup>(1)</sup> <sup>(2)</sup> <sup>(3)</sup>

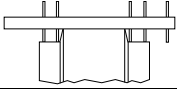

Depth Gauge

Inches	(mm)	% Worn
0.88	(22.5)	0
0.90	(23.0)	7
0.92	(23.5)	14
0.94	(24.0)	21
0.96	(24.5)	28
0.98	(25.0)	35
1.00	(25.5)	42
1.02	(26.0)	49
1.04	(26.5)	52
1.06	(27.0)	55
1.08	(27.5)	58
1.10	(28.0)	61
1.12	(28.5)	64
1.14	(29.0)	67
1.16	(29.5)	70
1.18	(30.0)	73
1.20	(30.5)	76
1.22	(31.0)	79
1.24	(31.5)	82
1.26	(32.0)	85
1.28	(32.5)	88
1.30	(33.0)	91
1.32	(33.5)	94
1.34	(34.0)	97
1.36	(34.5)	100
1.38	(35.0)	103
1.40	(35.5)	106
1.42	(36.0)	109
1.44	(36.5)	112
1.46	(37.0)	115
1.48	(37.5)	118
1.50	(38.0)	121

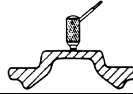

Ultrasonic

Center Flange Wear

Inches	(mm)	Inches	(mm)
0.48	(12.2)	0.00	(0.0)
0.46	(11.7)	0.02	(0.5)
0.44	(11.2)	0.04	(1.0)
0.42	(10.7)	0.06	(1.5)
0.40	(10.2)	0.08	(2.0)
0.38	(9.7)	0.10	(2.5)
0.36	(9.1)	0.12	(3.0)
0.34	(8.6)	0.14	(3.5)
0.32	(8.1)	0.16	(4.0)
0.30	(7.6)	0.18	(4.5)
0.28	(7.1)	0.20	(5.0)
0.26	(6.6)	0.22	(5.5)
0.24	(6.1)	0.24	(6.0)
0.22	(5.6)	0.26	(6.5)
0.20	(5.1)	0.28	(7.0)
0.18	(4.6)	0.30	(7.5)
0.16	(4.1)	0.32	(8.0)
0.14	(3.6)	0.34	(8.5)
0.12	(3.0)	0.36	(9.0)
0.10	(2.5)	0.38	(9.5)
0.08	(2.0)	0.40	(10.0)
0.06	(1.5)	0.42	(10.5)
0.04	(1.0)	0.44	(11.0)
0.02	(0.5)	0.46	(11.5)

**NOTE**

Ultrasonic measurement is to determine flange wear only.  
Use the ultrasonic only on fabricated idlers.

- 1 Flange width is 5.09 in. (129.3 mm)
- 2 New tread diameter is 28.74 in. (730 mm), 29.13 in. (740 mm) or 30.31 in. (770 mm)
- 3 Wear Chart: 4485

**365, 374, 375, 385, 390, 5080, 5090 - 10.25 in. (260.4 mm)**

**Carrier Rollers <sup>(1)</sup>**

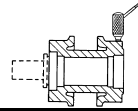
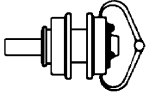

Caliper			Ultrasonic	
Inches	(mm)	% Worn	Inches	(mm)
7.48	(190.0)	0	1.41	(35.8)
7.44	(189.0)	5	1.39	(35.3)
7.40	(188.0)	10	1.37	(34.8)
7.36	(187.0)	15	1.35	(34.3)
7.32	(186.0)	20	1.33	(33.8)
7.28	(185.0)	25	1.31	(33.3)
7.24	(184.0)	30	1.29	(32.8)
7.20	(183.0)	35	1.27	(32.3)
7.16	(182.0)	40	1.25	(31.8)
7.12	(181.0)	45	1.23	(31.2)
7.08	(180.0)	50	1.21	(30.7)
7.04	(179.0)	55	1.19	(30.2)
7.00	(178.0)	60	1.17	(29.7)
6.96	(177.0)	65	1.15	(29.2)
6.92	(176.0)	70	1.13	(28.7)
6.88	(175.0)	75	1.11	(28.2)
6.84	(173.5)	80	1.09	(27.7)
6.80	(172.5)	85	1.07	(27.2)
6.76	(171.5)	88	1.05	(26.7)
6.72	(170.5)	91	1.03	(26.2)
6.68	(169.5)	94	1.01	(25.7)
6.64	(168.5)	97	0.99	(25.1)
6.60	(167.5)	100	0.97	(24.6)
6.56	(166.5)	103	0.95	(24.1)
6.52	(165.5)	106	0.93	(23.6)
6.48	(164.5)	109	0.91	(23.1)
6.44	(163.5)	112	0.89	(22.6)
6.40	(162.5)	115	0.87	(22.1)
6.36	(161.5)	118	0.85	(21.6)
6.32	(160.5)	121	0.83	(21.1)



**Track Rollers <sup>(1) (2)</sup>**  
**Only use for 365 and 374**

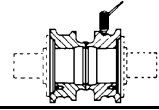
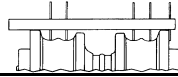
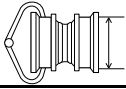

Caliper		% Worn	Depth Gauge		Ultrasonic	
Inches	(mm)		Inches	(mm)	Inches	(mm)
9.07	(230.5)	0	0.85	(21.5)	2.32	(58.9)
9.03	(229.5)	6	0.87	(22.0)	2.30	(58.4)
8.99	(228.5)	12	0.89	(22.5)	2.28	(57.9)
8.95	(227.5)	18	0.91	(23.0)	2.26	(57.4)
8.91	(226.5)	24	0.93	(23.5)	2.24	(56.9)
8.87	(225.5)	30	0.95	(24.0)	2.22	(56.4)
8.83	(224.5)	36	0.97	(24.5)	2.20	(55.9)
8.79	(223.5)	42	0.99	(25.0)	2.18	(55.4)
8.75	(222.5)	48	1.01	(25.5)	2.16	(54.9)
8.71	(221.0)	54	1.03	(26.0)	2.14	(54.4)
8.67	(220.0)	60	1.05	(26.5)	2.12	(53.8)
8.63	(219.0)	66	1.07	(27.0)	2.10	(53.3)
8.59	(218.0)	72	1.09	(27.5)	2.08	(52.8)
8.55	(217.0)	76	1.11	(28.0)	2.06	(52.3)
8.51	(216.0)	80	1.13	(28.5)	2.04	(51.8)
8.47	(215.0)	84	1.15	(29.0)	2.02	(51.3)
8.43	(214.0)	88	1.17	(29.5)	2.00	(50.8)
8.39	(213.0)	92	1.19	(30.0)	1.98	(50.3)
8.35	(212.0)	96	1.21	(30.5)	1.96	(49.8)
8.31	(211.0)	100	1.23	(31.0)	1.94	(49.3)
8.27	(210.0)	104	1.25	(32.0)	1.92	(48.8)
8.23	(209.0)	108	1.27	(32.5)	1.90	(48.3)
8.19	(208.0)	112	1.29	(33.0)	1.88	(47.8)
8.15	(207.0)	116	1.31	(33.5)	1.86	(47.2)
8.11	(206.0)	120	1.33	(34.0)	1.84	(46.7)

1 Flange diameter is 10.79 in. (274 mm)  
 2 Wear Chart: 5390

**375, 385, 390, 5080, 5090 - 10.25 in. (260.4 mm)**

**Track Rollers <sup>(1) (2)</sup>  
Not for use on 365 and 374  
Rim Part Number 185-5100**

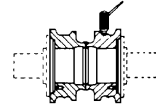
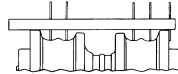
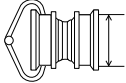

Caliper			Depth Gauge		Ultrasonic	
Inches	(mm)	% Worn	Inches	(mm)	Inches	(mm)
10.23	(260.0)	0	0.86	(22.0)	2.91	(73.9)
10.19	(259.0)	5	0.88	(22.5)	2.89	(73.4)
10.15	(258.0)	10	0.90	(23.0)	2.87	(72.9)
10.11	(257.0)	15	0.92	(23.5)	2.85	(72.4)
10.07	(256.0)	20	0.94	(24.0)	2.83	(71.9)
10.03	(255.0)	25	0.96	(24.5)	2.81	(71.4)
9.99	(253.5)	30	0.98	(25.0)	2.79	(70.9)
9.95	(252.5)	35	1.00	(25.5)	2.77	(70.4)
9.91	(251.5)	40	1.02	(26.0)	2.75	(69.9)
9.87	(250.5)	45	1.04	(26.5)	2.73	(69.3)
9.83	(249.5)	50	1.06	(27.0)	2.71	(68.8)
9.79	(248.5)	55	1.08	(27.5)	2.69	(68.3)
9.75	(247.5)	60	1.10	(28.0)	2.67	(67.8)
9.71	(246.5)	64	1.12	(28.5)	2.65	(67.3)
9.67	(245.5)	67	1.14	(29.0)	2.63	(66.8)
9.63	(244.5)	70	1.16	(29.5)	2.61	(66.3)
9.59	(243.5)	73	1.18	(30.0)	2.59	(65.8)
9.55	(242.5)	76	1.20	(30.5)	2.57	(65.3)
9.51	(241.5)	79	1.22	(31.0)	2.55	(64.8)
9.47	(240.5)	82	1.24	(31.5)	2.53	(64.3)
9.43	(239.5)	85	1.26	(32.0)	2.51	(63.8)
9.39	(238.5)	88	1.28	(32.5)	2.49	(63.2)
9.35	(237.5)	91	1.30	(33.0)	2.47	(62.7)
9.31	(236.5)	94	1.32	(33.5)	2.45	(62.2)
9.27	(235.5)	97	1.34	(34.0)	2.43	(61.7)
9.23	(234.5)	100	1.36	(34.5)	2.41	(61.2)
9.19	(233.5)	103	1.38	(35.0)	2.39	(60.7)
9.15	(232.5)	106	1.40	(35.5)	2.37	(60.2)
9.11	(231.5)	109	1.42	(36.0)	2.35	(59.7)
9.07	(230.5)	112	1.44	(36.5)	2.33	(59.2)
9.03	(229.5)	115	1.46	(37.0)	2.31	(58.7)
8.99	(228.5)	118	1.48	(37.5)	2.29	(58.2)
8.95	(227.5)	121	1.50	(38.0)	2.27	(57.7)

**Caution:** If measuring using Ultrasonic Wear indicator, ensure usage of the appropriate Track Roller wear chart 5388: UWI 'new' - 2.91 in. (73.9 mm) or 5382: UWI 'new' = 2.71 in. (68.8 mm)

- 1 Flange diameter is 11.97 in. (304 mm)
- 2 Wear Chart: 5388

## 375, 385, 390, 5080, 5090 - 10.25 in. (260.4 mm)

**Track Rollers<sup>(1) (2)</sup>**  
**Not for use on 365 and 374**  
**Rim Part Number 366-3379**

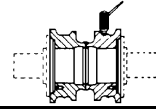
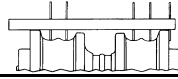
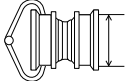

Caliper			Depth Gauge		Ultrasonic	
Inches	(mm)	% Worn	Inches	(mm)	Inches	(mm)
10.23	(260.0)	0	0.86	(22.0)	2.91	(73.9)
10.19	(259.0)	5	0.88	(22.5)	2.89	(73.4)
10.15	(258.0)	10	0.90	(23.0)	2.87	(72.9)
10.11	(257.0)	15	0.92	(23.5)	2.85	(72.4)
10.07	(256.0)	20	0.94	(24.0)	2.83	(71.9)
10.03	(255.0)	25	0.96	(24.5)	2.81	(71.4)
9.99	(253.5)	30	0.98	(25.0)	2.79	(70.9)
9.95	(252.5)	35	1.00	(25.5)	2.77	(70.4)
9.91	(251.5)	40	1.02	(26.0)	2.75	(69.9)
9.87	(250.5)	45	1.04	(26.5)	2.73	(69.3)
9.83	(249.5)	50	1.06	(27.0)	2.71	(68.8)
9.79	(248.5)	55	1.08	(27.5)	2.69	(68.3)
9.75	(247.5)	60	1.10	(28.0)	2.67	(67.8)
9.71	(246.5)	64	1.12	(28.5)	2.65	(67.3)
9.67	(245.5)	67	1.14	(29.0)	2.63	(66.8)
9.63	(244.5)	70	1.16	(29.5)	2.61	(66.3)
9.59	(243.5)	73	1.18	(30.0)	2.59	(65.8)
9.55	(242.5)	76	1.20	(30.5)	2.57	(65.3)
9.51	(241.5)	79	1.22	(31.0)	2.55	(64.8)
9.47	(240.5)	82	1.24	(31.5)	2.53	(64.3)
9.43	(239.5)	85	1.26	(32.0)	2.51	(63.8)
9.39	(238.5)	88	1.28	(32.5)	2.49	(63.2)
9.35	(237.5)	91	1.30	(33.0)	2.47	(62.7)
9.31	(236.5)	94	1.32	(33.5)	2.45	(62.2)
9.27	(235.5)	97	1.34	(34.0)	2.43	(61.7)
9.23	(234.5)	100	1.36	(34.5)	2.41	(61.2)
9.19	(233.5)	103	1.38	(35.0)	2.39	(60.7)
9.15	(232.5)	106	1.40	(35.5)	2.37	(60.2)
9.11	(231.5)	109	1.42	(36.0)	2.35	(59.7)
9.07	(230.5)	112	1.44	(36.5)	2.33	(59.2)
9.03	(229.5)	115	1.46	(37.0)	2.31	(58.7)
8.99	(228.5)	118	1.48	(37.5)	2.29	(58.2)
8.95	(227.5)	121	1.50	(38.0)	2.27	(57.7)

**Caution:** If measuring using Ultrasonic Wear indicator, ensure usage of the appropriate Track Roller wear chart 5388: UWI 'new' - 2.91 in. (73.9 mm) or 5382: UWI 'new' = 2.71 in. (68.8 mm)

- 1 Flange diameter is 11.97 in. (304 mm)
- 2 Wear Chart: 5382



Track Links <sup>(1)</sup>  
9W-5933 & 34

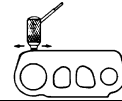
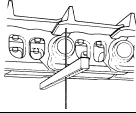

Depth Gauge			Ultrasonic	
Inches	(mm)	% Worn	Inches	(mm)
7.12	(181.0)	0	1.92	(48.8)
7.10	(180.5)	5	1.90	(48.3)
7.08	(180.0)	10	1.88	(47.8)
7.06	(179.5)	15	1.86	(47.2)
7.04	(179.0)	20	1.84	(46.7)
7.02	(178.5)	25	1.82	(46.2)
7.00	(178.0)	30	1.80	(45.7)
6.98	(177.5)	35	1.78	(45.2)
6.96	(177.0)	40	1.76	(44.7)
6.94	(176.5)	45	1.74	(44.2)
6.92	(176.0)	50	1.72	(43.7)
6.90	(175.5)	55	1.70	(43.2)
6.88	(175.0)	60	1.68	(42.7)
6.86	(174.0)	65	1.66	(42.2)
6.84	(173.5)	70	1.64	(41.7)
6.82	(173.0)	73	1.62	(41.1)
6.80	(172.5)	76	1.60	(40.6)
6.78	(172.0)	79	1.58	(40.1)
6.76	(171.5)	82	1.56	(39.6)
6.74	(171.0)	85	1.54	(39.1)
6.72	(170.5)	88	1.52	(38.6)
6.70	(170.0)	91	1.50	(38.1)
6.68	(169.5)	94	1.48	(37.6)
6.66	(169.0)	97	1.46	(37.1)
6.64	(168.5)	100	1.44	(36.6)
6.62	(168.0)	103	1.42	(36.1)
6.60	(167.5)	106	1.40	(35.6)
6.58	(167.0)	109	1.38	(35.1)
6.56	(166.5)	112	1.36	(34.5)
6.54	(166.0)	115	1.34	(34.0)
6.52	(165.5)	118	1.32	(33.5)
6.50	(165.0)	121	1.30	(33.0)

# 5110 - 10.25 in. (260.4 mm)

## Pins and Bushings <sup>(1)</sup> Internal Wear Sealed Track

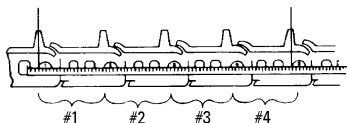

Inches	(mm)	% Worn
41.05	(1042.5)	0
41.10	(1044.0)	10
41.15	(1045.0)	20
41.20	(1046.5)	30
41.25	(1048.0)	40
41.30	(1049.0)	50
41.35	(1050.5)	60
41.40	(1051.5)	70
41.45	(1053.0)	80
41.50	(1054.0)	90
41.55	(1055.5)	100
41.60	(1056.5)	105
41.65	(1058.0)	110
41.70	(1059.0)	115
41.75	(1060.5)	120

1 Wear Chart: 480

**Bushings <sup>(1)</sup>  
External Wear  
Sealed Track**



**Caliper**

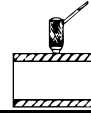

**Ultrasonic**

Caliper		% Worn	Ultrasonic	
Inches	(mm)		Inches	(mm)
3.81	(96.8)	0	0.76	(19.3)
3.80	(96.5)	5	0.75	(19.1)
3.79	(96.3)	10	0.74	(18.8)
3.78	(96.0)	15	0.73	(18.5)
3.77	(95.8)	20	0.72	(18.3)
3.76	(95.5)	25	0.71	(18.0)
3.75	(95.3)	30	0.70	(17.8)
3.74	(95.0)	35	0.69	(17.5)
3.73	(94.7)	40	0.68	(17.3)
3.72	(94.5)	45	0.67	(17.0)
3.71	(94.2)	50	0.66	(16.8)
3.70	(94.0)	55	0.65	(16.5)
3.69	(93.7)	60	0.64	(16.3)
3.68	(93.5)	65	0.63	(16.0)
3.67	(93.2)	68	0.62	(15.7)
3.66	(93.0)	70	0.61	(15.5)
3.65	(92.7)	72	0.60	(15.2)
3.64	(92.5)	74	0.59	(15.0)
3.63	(92.2)	76	0.58	(14.7)
3.62	(91.9)	78	0.57	(14.5)
3.61	(91.7)	80	0.56	(14.2)
3.60	(91.4)	82	0.55	(14.0)
3.59	(91.2)	84	0.54	(13.7)
3.58	(90.9)	86	0.53	(13.5)
3.57	(90.7)	88	0.52	(13.2)
3.56	(90.4)	90	0.51	(13.0)
3.55	(90.2)	92	0.50	(12.7)
3.54	(89.9)	94	0.49	(12.4)
3.53	(89.7)	96	0.48	(12.2)
3.52	(89.4)	98	0.47	(11.9)
3.51	(89.2)	100	0.46	(11.7)
3.50	(88.9)	102	0.45	(11.4)
3.49	(88.6)	104	0.44	(11.2)
3.48	(88.4)	106	0.43	(10.9)
3.47	(88.1)	108	0.42	(10.7)
3.46	(87.9)	110	0.41	(10.4)
3.45	(87.6)	112	0.40	(10.2)
3.44	(87.4)	114	0.39	(9.9)
3.43	(87.1)	116	0.38	(9.7)
3.42	(86.9)	118	0.37	(9.4)
3.41	(86.6)	120	0.36	(9.1)

# 5110 - 10.25 in. (260.4 mm)

## Track Shoes <sup>(1)</sup> Double Grouser

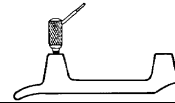
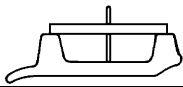

Depth Gauge			Ultrasonic	
Inches	(mm)	% Worn	Inches	(mm)
1.96	(49.5)	0	2.95	(75.0)
1.91	(48.5)	5	2.90	(73.7)
1.86	(47.0)	10	2.85	(72.5)
1.81	(46.0)	15	2.80	(71.2)
1.76	(44.5)	20	2.75	(69.9)
1.71	(43.5)	25	2.70	(68.7)
1.66	(42.0)	30	2.65	(67.4)
1.61	(41.0)	35	2.60	(66.1)
1.56	(39.5)	40	2.55	(64.8)
1.51	(38.0)	45	2.50	(63.6)
1.46	(37.0)	50	2.45	(62.3)
1.41	(35.5)	55	2.40	(61.0)
1.36	(34.5)	60	2.35	(59.8)
1.31	(33.0)	65	2.30	(58.5)
1.26	(32.0)	70	2.25	(57.2)
1.21	(30.5)	75	2.20	(56.0)
1.16	(29.5)	80	2.15	(54.7)
1.11	(28.0)	84	2.10	(53.4)
1.06	(27.0)	88	2.05	(52.1)
1.01	(25.5)	92	2.00	(50.9)
0.96	(24.5)	96	1.95	(49.6)
0.91	(23.0)	100	1.90	(48.3)
0.86	(21.5)	104	1.85	(47.1)
0.81	(20.5)	108	1.80	(45.8)
0.76	(19.0)	112	1.75	(44.5)
0.71	(18.0)	116	1.70	(43.3)
0.66	(16.5)	120	1.65	(42.0)

1 Wear Chart: 2281



Idlers <sup>(1)</sup> <sup>(2)</sup> <sup>(3)</sup>

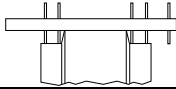

Depth Gauge

Inches	(mm)	% Worn
1.18	(30.0)	0
1.20	(30.5)	6
1.22	(31.0)	12
1.24	(31.5)	18
1.26	(32.0)	24
1.28	(32.5)	30
1.30	(33.0)	36
1.32	(33.5)	42
1.34	(34.0)	48
1.36	(34.5)	54
1.38	(35.0)	60
1.40	(35.5)	66
1.42	(36.0)	72
1.44	(36.5)	74
1.46	(37.0)	76
1.48	(37.5)	78
1.50	(38.0)	80
1.52	(38.5)	82
1.54	(39.0)	84
1.56	(39.5)	86
1.58	(40.0)	88
1.60	(40.5)	90
1.62	(41.0)	92
1.64	(41.5)	94
1.66	(42.0)	96
1.68	(42.5)	98
1.70	(43.0)	100
1.72	(43.5)	102
1.74	(44.0)	104
1.76	(44.5)	106
1.78	(45.0)	108
1.80	(45.5)	110
1.82	(46.0)	112
1.84	(46.5)	114
1.86	(47.0)	116
1.88	(48.0)	118
1.90	(48.5)	120

- 1 Flange width is 4.96 in. (126 mm)
- 2 New tread diameter is 33.94 in. (862 mm)
- 3 Wear Chart: 4486

**5110 - 10.25 in. (260.4 mm)**

**Carrier Rollers <sup>(1)</sup>**

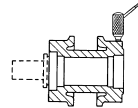
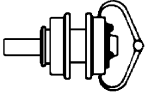

Caliper			Ultrasonic	
Inches	(mm)	% Worn	Inches	(mm)
9.05	(230.0)	0	2.54	(64.5)
8.97	(228.0)	8	2.50	(63.5)
8.89	(226.0)	16	2.46	(62.5)
8.81	(224.0)	24	2.42	(61.5)
8.73	(221.5)	32	2.38	(60.5)
8.65	(219.5)	40	2.34	(59.4)
8.57	(217.5)	44	2.30	(58.4)
8.49	(215.5)	48	2.26	(57.4)
8.41	(213.5)	52	2.22	(56.4)
8.33	(211.5)	56	2.18	(55.4)
8.25	(209.5)	60	2.14	(54.4)
8.17	(207.5)	64	2.10	(53.3)
8.09	(205.5)	68	2.06	(52.3)
8.01	(203.5)	72	2.02	(51.3)
7.93	(201.5)	76	1.98	(50.3)
7.85	(199.5)	80	1.94	(49.3)
7.77	(197.5)	84	1.90	(48.3)
7.69	(195.5)	88	1.86	(47.2)
7.61	(193.5)	92	1.82	(46.2)
7.53	(191.5)	96	1.78	(45.2)
7.45	(189.0)	100	1.74	(44.2)
7.37	(187.0)	104	1.70	(43.2)
7.29	(185.0)	108	1.66	(42.2)
7.21	(183.0)	112	1.62	(41.1)
7.13	(181.0)	116	1.58	(40.1)
7.05	(179.0)	120	1.54	(39.1)

1 Wear Chart: 4800

Track Rollers <sup>(1)</sup> <sup>(2)</sup>

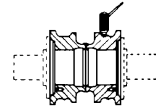
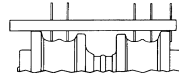
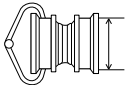

Caliper			Depth Gauge		Ultrasonic	
Inches	(mm)	% Worn	Inches	(mm)	Inches	(mm)
11.22	(285.0)	0	1.18	(30.0)	3.06	(77.7)
11.18	(284.0)	6	1.20	(30.5)	3.04	(77.2)
11.14	(283.0)	12	1.22	(31.0)	3.02	(76.7)
11.10	(282.0)	18	1.24	(31.5)	3.00	(76.2)
11.06	(281.0)	24	1.26	(32.0)	2.98	(75.7)
11.02	(280.0)	30	1.28	(32.5)	2.96	(75.2)
10.98	(279.0)	36	1.30	(33.0)	2.94	(74.7)
10.94	(278.0)	42	1.32	(33.5)	2.92	(74.2)
10.90	(277.0)	46	1.34	(34.0)	2.90	(73.7)
10.86	(276.0)	49	1.36	(34.5)	2.88	(73.2)
10.82	(275.0)	52	1.38	(35.0)	2.86	(72.6)
10.78	(274.0)	55	1.40	(35.5)	2.84	(72.1)
10.74	(273.0)	58	1.42	(36.0)	2.82	(71.6)
10.70	(272.0)	61	1.44	(36.5)	2.80	(71.1)
10.66	(271.0)	64	1.46	(37.0)	2.78	(70.6)
10.62	(269.5)	67	1.48	(37.5)	2.76	(70.1)
10.58	(268.5)	70	1.50	(38.0)	2.74	(69.6)
10.54	(267.5)	73	1.52	(38.5)	2.72	(69.1)
10.50	(266.5)	76	1.54	(39.0)	2.70	(68.6)
10.46	(265.5)	79	1.56	(39.5)	2.68	(68.1)
10.42	(264.5)	82	1.58	(40.0)	2.66	(67.6)
10.38	(263.5)	85	1.60	(40.5)	2.64	(67.1)
10.34	(262.5)	88	1.62	(41.0)	2.62	(66.5)
10.30	(261.5)	91	1.64	(41.5)	2.60	(66.0)
10.26	(260.5)	94	1.66	(42.0)	2.58	(65.5)
10.22	(259.5)	97	1.68	(42.5)	2.56	(65.0)
10.18	(258.5)	100	1.70	(43.0)	2.54	(64.5)
10.14	(257.5)	103	1.72	(43.5)	2.52	(64.0)
10.10	(256.5)	106	1.74	(44.0)	2.50	(63.5)
10.06	(255.5)	109	1.76	(44.5)	2.48	(63.0)
10.02	(254.5)	112	1.78	(45.0)	2.46	(62.5)
9.98	(253.5)	115	1.80	(45.5)	2.44	(62.0)
9.94	(252.5)	118	1.82	(46.0)	2.42	(61.5)
9.90	(251.5)	121	1.84	(46.5)	2.40	(61.0)

1 Flange diameter is 13.58 in. (345 mm)  
 2 Wear Chart: 5389

**5110 - 10.25 in. (260.4 mm)**

**Sprockets <sup>(1)</sup>**

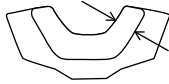

**Caliper**

Inches	(mm)	% Worn
1.55	(39.5)	0
1.50	(38.0)	6
1.45	(37.0)	12
1.40	(35.5)	18
1.35	(34.5)	24
1.30	(33.0)	30
1.25	(32.0)	36
1.20	(30.5)	42
1.15	(29.0)	48
1.10	(28.0)	54
1.05	(26.5)	60
1.00	(25.5)	66
0.95	(24.0)	72
0.90	(23.0)	78
0.85	(21.5)	84
0.80	(20.5)	90
0.75	(19.0)	94
0.70	(18.0)	97
0.65	(16.5)	100
0.60	(15.0)	103
0.55	(14.0)	106
0.50	(12.5)	109
0.45	(11.5)	112
0.40	(10.0)	115
0.35	(9.0)	118
0.30	(7.5)	121

1 Wear Chart: 7182

**Track Links <sup>(1)</sup>**  
**6I-8643 & 44**  
**6T-8049 & 50**

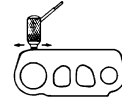
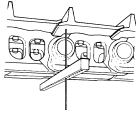

Depth Gauge			Ultrasonic	
Inches	(mm)	% Worn	Inches	(mm)
7.79	(198.0)	0	2.24	(56.9)
7.77	(197.5)	5	2.22	(56.4)
7.75	(197.0)	10	2.20	(55.9)
7.73	(196.5)	15	2.18	(55.4)
7.71	(196.0)	20	2.16	(54.9)
7.69	(195.5)	25	2.14	(54.4)
7.67	(195.0)	30	2.12	(53.8)
7.65	(194.5)	35	2.10	(53.3)
7.63	(194.0)	40	2.08	(52.8)
7.61	(193.5)	45	2.06	(52.3)
7.59	(193.0)	50	2.04	(51.8)
7.57	(192.5)	55	2.02	(51.3)
7.55	(192.0)	60	2.00	(50.8)
7.53	(191.5)	65	1.98	(50.3)
7.51	(191.0)	70	1.96	(49.8)
7.49	(190.0)	73	1.94	(49.3)
7.47	(189.5)	76	1.92	(48.8)
7.45	(189.0)	79	1.90	(48.3)
7.43	(188.5)	82	1.88	(47.8)
7.41	(188.0)	85	1.86	(47.2)
7.39	(187.5)	88	1.84	(46.7)
7.37	(187.0)	91	1.82	(46.2)
7.35	(186.5)	94	1.80	(45.7)
7.33	(186.0)	97	1.78	(45.2)
7.31	(185.5)	100	1.76	(44.7)
7.29	(185.0)	103	1.74	(44.2)
7.27	(184.5)	106	1.72	(43.7)
7.25	(184.0)	109	1.70	(43.2)
7.23	(183.5)	112	1.68	(42.7)
7.21	(183.0)	115	1.66	(42.2)
7.19	(182.5)	118	1.64	(41.7)
7.17	(182.0)	121	1.62	(41.1)

# 5130 - 12.50 in. (317.5 mm)

## Pins and Bushings <sup>(1)</sup> Internal Wear Sealed Track

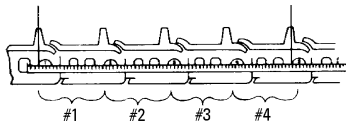

Inches	(mm)	% Worn
50.05	(1271.5)	0
50.10	(1272.5)	10
50.15	(1274.0)	20
50.20	(1275.0)	30
50.25	(1276.5)	40
50.30	(1277.5)	50
50.35	(1279.0)	60
50.40	(1280.0)	70
50.45	(1281.5)	80
50.50	(1282.5)	90
50.55	(1284.0)	100
50.60	(1285.0)	105
50.65	(1286.5)	110
50.70	(1288.0)	115
50.75	(1289.0)	120

1 Wear Chart: 500

**Bushings <sup>(1)</sup>  
External Wear  
Sealed Track**

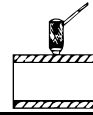

**Caliper**

**Ultrasonic**

Inches	(mm)	% Worn	Inches	(mm)
4.32	(109.7)	0	0.82	(20.8)
4.31	(109.5)	4	0.81	(20.6)
4.30	(109.2)	8	0.80	(20.3)
4.29	(109.0)	12	0.79	(20.1)
4.28	(108.7)	16	0.78	(19.8)
4.27	(108.5)	20	0.77	(19.6)
4.26	(108.2)	24	0.76	(19.3)
4.25	(108.0)	28	0.75	(19.1)
4.24	(107.7)	32	0.74	(18.8)
4.23	(107.4)	36	0.73	(18.5)
4.22	(107.2)	40	0.72	(18.3)
4.21	(106.9)	43	0.71	(18.0)
4.20	(106.7)	46	0.70	(17.8)
4.19	(106.4)	49	0.69	(17.5)
4.18	(106.2)	52	0.68	(17.3)
4.17	(105.9)	55	0.67	(17.0)
4.16	(105.7)	58	0.66	(16.8)
4.15	(105.4)	61	0.65	(16.5)
4.14	(105.2)	64	0.64	(16.3)
4.13	(104.9)	67	0.63	(16.0)
4.12	(104.6)	70	0.62	(15.7)
4.11	(104.4)	73	0.61	(15.5)
4.10	(104.1)	76	0.60	(15.2)
4.09	(103.9)	79	0.59	(15.0)
4.08	(103.6)	82	0.58	(14.7)
4.07	(103.4)	85	0.57	(14.5)
4.06	(103.1)	88	0.56	(14.2)
4.05	(102.9)	91	0.55	(14.0)
4.04	(102.6)	94	0.54	(13.7)
4.03	(102.4)	97	0.53	(13.5)
4.02	(102.1)	100	0.52	(13.2)
4.01	(101.9)	103	0.51	(13.0)
4.00	(101.6)	106	0.50	(12.7)
3.99	(101.3)	109	0.49	(12.4)
3.98	(101.1)	112	0.48	(12.2)
3.97	(100.8)	115	0.47	(11.9)
3.96	(100.6)	118	0.46	(11.7)
3.95	(100.3)	121	0.45	(11.4)

**5130 - 12.50 in. (317.5 mm)**

**Track Shoes <sup>(1)</sup>  
Double Grouser  
Tall Grouser Shoe**

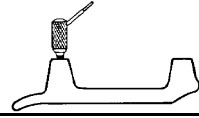
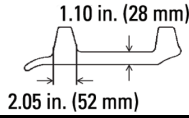
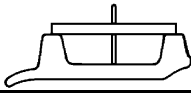

**Depth Gauge**

**Ultrasonic**

Inches	(mm)	% Worn	Inches	(mm)
2.90	(73.5)	0	4.02	(102.0)
2.80	(71.0)	6	3.92	(99.5)
2.70	(68.5)	12	3.82	(96.9)
2.60	(66.0)	18	3.72	(94.4)
2.50	(63.5)	24	3.62	(91.8)
2.40	(61.0)	30	3.52	(89.3)
2.30	(58.5)	35	3.42	(86.8)
2.20	(56.0)	40	3.32	(84.2)
2.10	(53.5)	45	3.22	(81.7)
2.00	(51.0)	50	3.12	(79.1)
1.90	(48.5)	55	3.02	(76.6)
1.80	(45.5)	60	2.92	(74.1)
1.70	(43.0)	65	2.82	(71.5)
1.60	(40.5)	70	2.72	(69.0)
1.50	(38.0)	75	2.62	(66.4)
1.40	(35.5)	80	2.52	(63.9)
1.30	(33.0)	85	2.42	(61.4)
1.20	(30.5)	90	2.32	(58.8)
1.10	(28.0)	95	2.22	(56.3)
1.00	(25.5)	100	2.12	(53.7)
0.90	(23.0)	105	2.02	(51.2)
0.80	(20.5)	110	1.92	(48.7)
0.70	(18.0)	115	1.82	(46.1)
0.60	(15.0)	120	1.72	(43.6)



**Track Shoes <sup>(1)</sup>  
Double Grouser  
(Original Forged [semi-flat] shoe)**

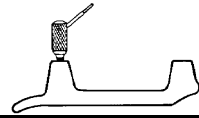
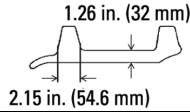
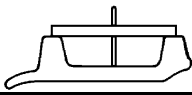

**Depth Gauge**

**Ultrasonic**

Inches	(mm)	% Worn	Inches	(mm)
2.94	(74.5)	0	4.21	(107.0)
2.84	(72.0)	6	4.11	(104.5)
2.74	(69.5)	12	4.01	(101.9)
2.64	(67.0)	18	3.91	(99.4)
2.54	(64.5)	24	3.81	(96.8)
2.44	(62.0)	30	3.71	(94.3)
2.34	(59.5)	35	3.61	(91.8)
2.24	(57.0)	40	3.51	(89.2)
2.14	(54.5)	45	3.41	(86.7)
2.04	(52.0)	50	3.31	(84.1)
1.94	(49.5)	55	3.21	(81.6)
1.84	(46.5)	60	3.11	(79.1)
1.74	(44.0)	65	3.01	(76.5)
1.64	(41.5)	70	2.91	(74.0)
1.54	(39.0)	75	2.81	(71.4)
1.44	(36.5)	80	2.71	(68.9)
1.34	(34.0)	85	2.61	(66.4)
1.24	(31.5)	90	2.51	(63.8)
1.14	(29.0)	95	2.41	(61.3)
1.04	(26.5)	100	2.31	(58.7)
0.94	(24.0)	105	2.21	(56.2)
0.84	(21.5)	110	2.11	(53.7)
0.74	(19.0)	115	2.01	(51.1)
0.64	(16.5)	120	1.91	(48.6)

# 5130 - 12.50 in. (317.5 mm)

Idlers <sup>(1)</sup> <sup>(2)</sup> <sup>(3)</sup>

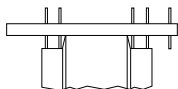

**Depth Gauge**

Inches	(mm)	% Worn
1.54	(39.0)	0
1.56	(39.5)	6
1.58	(40.0)	12
1.60	(40.5)	18
1.62	(41.0)	24
1.64	(41.5)	30
1.66	(42.0)	36
1.68	(42.5)	42
1.70	(43.0)	48
1.72	(43.5)	54
1.74	(44.0)	60
1.76	(44.5)	66
1.78	(45.0)	72
1.80	(45.5)	76
1.82	(46.0)	78
1.84	(46.5)	80
1.86	(47.0)	82
1.88	(48.0)	84
1.90	(48.5)	86
1.92	(49.0)	88
1.94	(49.5)	90
1.96	(50.0)	92
1.98	(50.5)	94
2.00	(51.0)	96
2.02	(51.5)	98
2.04	(52.0)	100
2.06	(52.5)	102
2.08	(53.0)	104
2.10	(53.5)	106
2.12	(54.0)	108
2.14	(54.5)	110
2.16	(55.0)	112
2.18	(55.5)	114
2.20	(56.0)	116
2.22	(56.5)	118
2.24	(57.0)	120

- 1 Flange width is 5.98 in. (152 mm)
- 2 New tread diameter is 42.05 in. (1068 mm)
- 3 Wear Chart: 4501

Carrier Rollers <sup>(1)</sup>

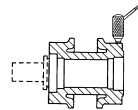
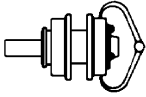

Caliper			Ultrasonic	
Inches	(mm)	% Worn	Inches	(mm)
9.05	(230.0)	0	2.54	(64.5)
8.97	(228.0)	8	2.50	(63.5)
8.89	(226.0)	16	2.46	(62.5)
8.81	(224.0)	24	2.42	(61.5)
8.73	(221.5)	32	2.38	(60.5)
8.65	(219.5)	40	2.34	(59.4)
8.57	(217.5)	44	2.30	(58.4)
8.49	(215.5)	48	2.26	(57.4)
8.41	(213.5)	52	2.22	(56.4)
8.33	(211.5)	56	2.18	(55.4)
8.25	(209.5)	60	2.14	(54.4)
8.17	(207.5)	64	2.10	(53.3)
8.09	(205.5)	68	2.06	(52.3)
8.01	(203.5)	72	2.02	(51.3)
7.93	(201.5)	76	1.98	(50.3)
7.85	(199.5)	80	1.94	(49.3)
7.77	(197.5)	84	1.90	(48.3)
7.69	(195.5)	88	1.86	(47.2)
7.61	(193.5)	92	1.82	(46.2)
7.53	(191.5)	96	1.78	(45.2)
7.45	(189.0)	100	1.74	(44.2)
7.37	(187.0)	104	1.70	(43.2)
7.29	(185.0)	108	1.66	(42.2)
7.21	(183.0)	112	1.62	(41.1)
7.13	(181.0)	116	1.58	(40.1)
7.05	(179.0)	120	1.54	(39.1)

# 5130 - 12.50 in. (317.5 mm)

## Track Rollers <sup>(1)</sup> <sup>(2)</sup>

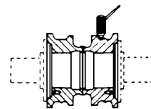
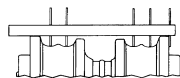
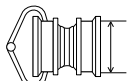

Caliper			Depth Gauge		Ultrasonic	
Inches	(mm)	% Worn	Inches	(mm)	Inches	(mm)
12.79	(325.0)	0	1.57	(40.0)	3.13	(79.5)
12.69	(322.5)	6	1.62	(41.0)	3.08	(78.2)
12.59	(320.0)	12	1.67	(42.5)	3.03	(77.0)
12.49	(317.0)	18	1.72	(43.5)	2.98	(75.7)
12.39	(314.5)	24	1.77	(45.0)	2.93	(74.4)
12.29	(312.0)	30	1.82	(46.0)	2.88	(73.2)
12.19	(309.5)	36	1.87	(47.5)	2.83	(71.9)
12.09	(307.0)	42	1.92	(49.0)	2.78	(70.6)
11.99	(304.5)	48	1.97	(50.0)	2.73	(69.3)
11.89	(302.0)	54	2.02	(51.5)	2.68	(68.1)
11.79	(299.5)	60	2.07	(52.5)	2.63	(66.8)
11.69	(297.0)	66	2.12	(54.0)	2.58	(65.5)
11.59	(294.5)	72	2.17	(55.0)	2.53	(64.3)
11.49	(292.0)	78	2.22	(56.5)	2.48	(63.0)
11.39	(289.5)	82	2.27	(57.5)	2.43	(61.7)
11.29	(287.0)	85	2.32	(59.0)	2.38	(60.5)
11.19	(284.0)	88	2.37	(60.0)	2.33	(59.2)
11.09	(281.5)	91	2.42	(61.5)	2.28	(57.9)
10.99	(279.0)	94	2.47	(62.5)	2.23	(56.6)
10.89	(276.5)	97	2.52	(64.0)	2.18	(55.4)
10.79	(274.0)	100	2.57	(65.5)	2.13	(54.1)
10.69	(271.5)	103	2.62	(66.5)	2.08	(52.8)
10.59	(269.0)	106	2.67	(68.0)	2.03	(51.6)
10.49	(266.5)	109	2.72	(69.0)	1.98	(50.3)
10.39	(264.0)	112	2.77	(70.5)	1.93	(49.0)
10.29	(261.5)	115	2.82	(71.5)	1.88	(47.8)
10.19	(259.0)	118	2.87	(73.0)	1.83	(46.5)
10.09	(256.5)	121	2.92	(74.0)	1.78	(45.2)

1 Flange diameter is 14.94 in. (405 mm)

2 Wear Chart: 5401

Sprockets <sup>(1)</sup>

Caliper

Inches	(mm)	% Worn
1.90	(48.5)	0
1.85	(47.0)	6
1.80	(45.5)	12
1.75	(44.5)	18
1.70	(43.0)	24
1.65	(42.0)	30
1.60	(40.5)	36
1.55	(39.5)	42
1.50	(38.0)	48
1.45	(37.0)	54
1.40	(35.5)	60
1.35	(34.5)	66
1.30	(33.0)	70
1.25	(32.0)	73
1.20	(30.5)	76
1.15	(29.0)	79
1.10	(28.0)	82
1.05	(26.5)	85
1.00	(25.5)	88
0.95	(24.0)	91
0.90	(23.0)	94
0.85	(21.5)	97
0.80	(20.5)	100
0.75	(19.0)	103
0.70	(18.0)	106
0.65	(16.5)	109
0.60	(15.0)	112
0.55	(14.0)	115
0.50	(12.5)	118
0.45	(11.5)	121

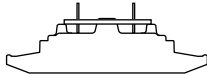

Track Links <sup>(1)</sup>

## Depth Gauge

Inches	(mm)	% Worn
1.85	(47.0)	0
1.87	(47.5)	6
1.89	(48.0)	12
1.91	(48.5)	18
1.93	(49.0)	24
1.95	(49.5)	30
1.97	(50.0)	36
1.99	(50.5)	42
2.01	(51.0)	48
2.03	(51.5)	54
2.05	(52.0)	60
2.07	(52.5)	66
2.09	(53.0)	72
2.11	(53.5)	78
2.13	(54.0)	84
2.15	(54.5)	90
2.17	(55.0)	94
2.19	(55.5)	97
2.21	(56.0)	100
2.23	(56.5)	103
2.25	(57.0)	106
2.27	(57.5)	109
2.29	(58.0)	112
2.31	(58.5)	115
2.33	(59.0)	118
2.35	(59.5)	121

**5230 - 14.90 in. (378.5 mm)**

**Pins and Bushings <sup>(1)</sup>  
Internal Wear  
Sealed Track**

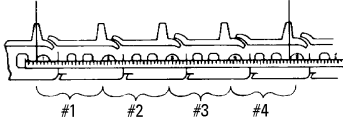

Inches	(mm)	% Worn
44.70	(1135.5)	0
44.75	(1136.5)	6
44.80	(1138.0)	12
44.85	(1139.0)	18
44.90	(1140.5)	24
44.95	(1141.5)	30
45.00	(1143.0)	36
45.05	(1144.5)	42
45.10	(1145.5)	48
45.15	(1147.0)	54
45.20	(1148.0)	60
45.25	(1149.5)	66
45.30	(1150.5)	72
45.35	(1152.0)	76
45.40	(1153.0)	79
45.45	(1154.5)	82
45.50	(1155.5)	85
45.55	(1157.0)	88
45.60	(1158.0)	91
45.65	(1159.5)	94
45.70	(1161.0)	97
45.75	(1162.0)	100
45.80	(1163.5)	103
45.85	(1164.5)	106
45.90	(1166.0)	109
45.95	(1167.0)	112
46.00	(1168.5)	115
46.05	(1169.5)	118
46.10	(1171.0)	121

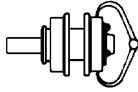

Carrier Rollers <sup>(1)</sup>

## Caliper

Inches	(mm)	% Worn
15.35	(390.0)	0
15.27	(388.0)	8
15.19	(386.0)	16
15.11	(384.0)	24
15.03	(382.0)	32
14.95	(379.5)	40
14.87	(377.5)	44
14.79	(375.5)	48
14.71	(373.5)	52
14.63	(371.5)	56
14.55	(369.5)	60
14.47	(367.5)	64
14.39	(365.5)	68
14.31	(363.5)	72
14.23	(361.5)	76
14.15	(359.5)	80
14.07	(357.5)	84
13.99	(355.5)	88
13.91	(353.5)	92
13.83	(351.5)	96
13.75	(349.5)	100
13.67	(347.0)	104
13.59	(345.0)	108
13.51	(343.0)	112
13.43	(341.0)	116
13.35	(339.0)	120

# 5230 - 14.90 in. (378.5 mm)

## Track Rollers <sup>(1)</sup>

Caliper			Ultrasonic		
Inches	(mm)	% Worn	Inches	(mm)	
19.45	(494.0)	0	5.78	(146.8)	
19.41	(493.0)	5	5.76	(146.3)	
19.37	(492.0)	10	5.74	(145.8)	
19.33	(491.0)	15	5.72	(145.3)	
19.29	(490.0)	20	5.70	(144.8)	
19.25	(489.0)	25	5.68	(144.3)	
19.21	(488.0)	30	5.66	(143.8)	
19.17	(487.0)	35	5.64	(143.3)	
19.13	(486.0)	40	5.62	(142.7)	
19.09	(485.0)	45	5.60	(142.2)	
19.05	(484.0)	50	5.58	(141.7)	
19.01	(483.0)	55	5.56	(141.2)	
18.97	(482.0)	60	5.54	(140.7)	
18.93	(481.0)	65	5.52	(140.2)	
18.89	(480.0)	68	5.50	(139.7)	
18.85	(479.0)	70	5.48	(139.2)	
18.81	(478.0)	72	5.46	(138.7)	
18.77	(477.0)	74	5.44	(138.2)	
18.73	(475.5)	76	5.42	(137.7)	
18.69	(474.5)	78	5.40	(137.2)	
18.65	(473.5)	80	5.38	(136.7)	
18.61	(472.5)	82	5.36	(136.1)	
18.57	(471.5)	84	5.34	(135.6)	
18.53	(470.5)	86	5.32	(135.1)	
18.49	(469.5)	88	5.30	(134.6)	
18.45	(468.5)	90	5.28	(134.1)	
18.41	(467.5)	92	5.26	(133.6)	
18.37	(466.5)	94	5.24	(133.1)	
18.33	(465.5)	96	5.22	(132.6)	
18.29	(464.5)	98	5.20	(132.1)	
18.25	(463.5)	100	5.18	(131.6)	
18.21	(462.5)	102	5.16	(131.1)	
18.17	(461.5)	104	5.14	(130.6)	
18.13	(460.5)	106	5.12	(130.0)	
18.09	(459.5)	108	5.10	(129.5)	
18.05	(458.5)	110	5.08	(129.0)	
18.01	(457.5)	112	5.06	(128.5)	
17.97	(456.5)	114	5.04	(128.0)	
17.93	(455.5)	116	5.02	(127.5)	
17.89	(454.5)	118	5.00	(127.0)	
17.85	(453.5)	120	4.98	(126.5)	

1 Wear Chart: 5440

Sprockets <sup>(1)</sup>

Caliper

Inches	(mm)	% Worn
4.14	(105.0)	0
4.05	(103.0)	5
3.96	(100.5)	10
3.87	(98.5)	15
3.78	(96.0)	20
3.69	(93.5)	25
3.60	(91.5)	30
3.51	(89.0)	35
3.42	(87.0)	40
3.33	(84.5)	45
3.24	(82.5)	50
3.15	(80.0)	55
3.06	(77.5)	58
2.97	(75.5)	60
2.88	(73.0)	62
2.79	(71.0)	64
2.70	(68.5)	66
2.61	(66.5)	68
2.52	(64.0)	70
2.43	(61.5)	72
2.34	(59.5)	74
2.25	(57.0)	76
2.16	(55.0)	78
2.07	(52.5)	80
1.98	(50.5)	82
1.89	(48.0)	84
1.80	(45.5)	86
1.71	(43.5)	88
1.62	(41.0)	90
1.53	(39.0)	92
1.44	(36.5)	94
1.35	(34.5)	96
1.26	(32.0)	98
1.17	(29.5)	100
1.08	(27.5)	102
0.99	(25.0)	104
0.90	(23.0)	106
0.81	(20.5)	108
0.72	(18.5)	110
0.63	(16.0)	112
0.54	(13.5)	114
0.45	(11.5)	116
0.36	(9.0)	118
0.27	(7.0)	120



## Paving Products/Drive Belts

PM465	5.31 in. (135 mm)	3A-9615 & 14	<a href="#">From, page 740 – To, page 747</a>
AP650, AP1050, BG225, BG245	6.125 in. (155.6 mm)	6Y-0935 & 36	<a href="#">From, page 748 – To, page 758</a>
SF250B, TR225B PR450B, SF350	6.125 in. (155.6 mm)	6Y-0935 & 36	<a href="#">From, page 759 – To, page 765</a>
PR750B, PR1000, SF550, SF500, TR500	6.75 in. (171.5 mm)	9K-6628 & 29	<a href="#">From, page 766 – To, page 771</a>
PM565	6.75 in. (171.5 mm)	9K-6628 & 29	<a href="#">From, page 772 – To, page 778</a>

# PM465 - 5.31 in. (135 mm)

## Track Links <sup>(1)</sup> 3A-9615 & 14

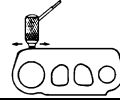
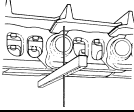

Depth Gauge			Ultrasonic	
Inches	(mm)	% Worn	Inches	(mm)
2.91	(74.0)	0	0.78	(19.8)
2.89	(73.5)	9	0.76	(19.3)
2.87	(73.0)	18	0.74	(18.8)
2.85	(72.5)	27	0.72	(18.3)
2.83	(72.0)	36	0.70	(17.8)
2.81	(71.5)	45	0.68	(17.3)
2.79	(71.0)	54	0.66	(16.8)
2.77	(70.5)	63	0.64	(16.3)
2.75	(70.0)	72	0.62	(15.7)
2.73	(69.5)	79	0.60	(15.2)
2.71	(69.0)	86	0.58	(14.7)
2.69	(68.5)	93	0.56	(14.2)
2.67	(68.0)	100	0.54	(13.7)
2.65	(67.5)	107	0.52	(13.2)
2.63	(67.0)	114	0.50	(12.7)
2.61	(66.5)	121	0.48	(12.2)

**Pins and Bushings <sup>(1)</sup>  
Internal Wear  
Sealed Track**

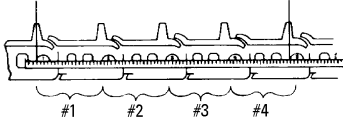

Inches	(mm)	% Worn
21.25	(540.0)	0
21.30	(541.0)	10
21.35	(542.5)	20
21.40	(543.5)	30
21.45	(545.0)	40
21.50	(546.0)	50
21.55	(547.5)	60
21.60	(548.5)	70
21.65	(550.0)	80
21.70	(551.0)	90
21.75	(552.5)	100
21.80	(553.5)	105
21.85	(555.0)	110
21.90	(556.5)	115
21.95	(557.5)	120

1 Wear Chart: 300

**PM465 — 5.31 in. (135 mm)**

**Bushings <sup>(1)</sup>  
External Wear  
Sealed Track**

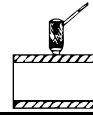

**Caliper**

**Ultrasonic**

<b>Caliper</b>		<b>% Worn</b>	<b>Ultrasonic</b>	
<b>Inches</b>	<b>(mm)</b>		<b>Inches</b>	<b>(mm)</b>
1.61	(40.9)	0	0.32	(8.1)
1.60	(40.6)	8	0.31	(7.9)
1.59	(40.4)	16	0.30	(7.6)
1.58	(40.1)	24	0.29	(7.4)
1.57	(39.9)	32	0.28	(7.1)
1.56	(39.6)	40	0.27	(6.9)
1.55	(39.4)	48	0.26	(6.6)
1.54	(39.1)	56	0.25	(6.4)
1.53	(38.9)	64	0.24	(6.1)
1.52	(38.6)	72	0.23	(5.8)
1.51	(38.4)	80	0.22	(5.6)
1.50	(38.1)	84	0.21	(5.3)
1.49	(37.8)	88	0.20	(5.1)
1.48	(37.6)	92	0.19	(4.8)
1.47	(37.3)	96	0.18	(4.6)
1.46	(37.1)	100	0.17	(4.3)
1.45	(36.8)	104	0.16	(4.1)
1.44	(36.6)	108	0.15	(3.8)
1.43	(36.3)	112	0.14	(3.6)
1.42	(36.1)	116	0.13	(3.3)
1.41	(35.8)	120	0.12	(3.0)

1 Wear Chart: 900



Track Shoes <sup>(1)</sup>  
 Rubber Grouser

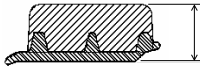

Depth Gauge

Inches	(mm)	% Worn
2.00	(51.0)	0
1.95	(49.5)	7
1.90	(48.5)	14
1.85	(47.0)	21
1.80	(45.5)	28
1.75	(44.5)	34
1.70	(43.0)	40
1.65	(42.0)	46
1.60	(40.5)	52
1.55	(39.5)	58
1.50	(38.0)	64
1.45	(37.0)	70
1.40	(35.5)	76
1.35	(34.5)	82
1.30	(33.0)	88
1.25	(32.0)	94
1.20	(30.5)	100
1.15	(29.0)	106
1.10	(28.0)	112
1.05	(26.5)	118
1.00	(25.5)	124

NOTE

Measure from the top of the grouser pad to the bottom of the mounting plate.

**PM465 — 5.31 in. (135 mm)**

**Idler** (1) (2) (3)  
**Current Idler**

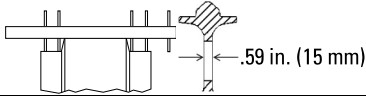

**Depth Gauge**

Inches	(mm)	% Worn
1.02	(26.0)	0
1.04	(26.5)	14
1.06	(27.0)	28
1.08	(27.5)	42
1.10	(28.0)	52
1.12	(28.5)	60
1.14	(29.0)	68
1.16	(29.5)	76
1.18	(30.0)	84
1.20	(30.5)	92
1.22	(31.0)	100
1.24	(31.5)	108
1.26	(32.0)	116
1.28	(32.5)	124

- 1 Flange width is 1.69 in. (43 mm)
- 2 New tread diameter is 15.75 in. (400 mm)
- 3 Wear Chart: 4303

**Idler** <sup>(1)</sup> <sup>(2)</sup>  
**Earlier Idler**

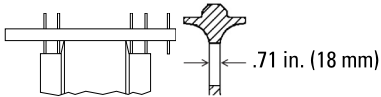

**Depth Gauge**

Inches	(mm)	% Worn
0.86	(22.0)	0
0.88	(22.5)	14
0.90	(23.0)	28
0.92	(23.5)	42
0.94	(24.0)	52
0.96	(24.5)	60
0.98	(25.0)	68
1.00	(25.5)	76
1.02	(26.0)	84
1.04	(26.5)	92
1.06	(27.0)	100
1.08	(27.5)	108
1.10	(28.0)	116
1.12	(28.5)	124

1 New tread diameter is 15.75 in. (400 mm)  
 2 Wear Chart: 4301

# PM465 — 5.31 in. (135 mm)

## Track Rollers <sup>(1) (2)</sup> Large Track Roller Flange

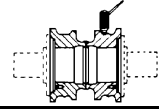
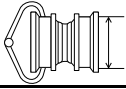

Caliper		% Worn	Depth Gauge		Ultrasonic	
Inches	(mm)		Inches	(mm)	Inches	(mm)
5.31	(135.0)	0	0.43	(11.0)	0.88	(22.4)
5.29	(134.5)	5	0.44	(11.0)	0.87	(22.1)
5.27	(134.0)	10	0.45	(11.5)	0.86	(21.8)
5.25	(133.5)	15	0.46	(11.5)	0.85	(21.6)
5.23	(133.0)	20	0.47	(12.0)	0.84	(21.3)
5.21	(132.5)	25	0.48	(12.0)	0.83	(21.1)
5.19	(132.0)	30	0.49	(12.5)	0.82	(20.8)
5.17	(131.5)	35	0.50	(12.5)	0.81	(20.6)
5.15	(131.0)	40	0.51	(13.0)	0.80	(20.3)
5.13	(130.5)	45	0.52	(13.0)	0.79	(20.1)
5.11	(130.0)	50	0.53	(13.5)	0.78	(19.8)
5.09	(129.5)	55	0.54	(13.5)	0.77	(19.6)
5.07	(129.0)	60	0.55	(14.0)	0.76	(19.3)
5.05	(128.5)	64	0.56	(14.0)	0.75	(19.1)
5.03	(128.0)	67	0.57	(14.5)	0.74	(18.8)
5.01	(127.5)	70	0.58	(14.5)	0.73	(18.5)
4.99	(126.5)	73	0.59	(15.0)	0.72	(18.3)
4.97	(126.0)	76	0.60	(15.0)	0.71	(18.0)
4.95	(125.5)	79	0.61	(15.5)	0.70	(17.8)
4.93	(125.0)	82	0.62	(15.5)	0.69	(17.5)
4.91	(124.5)	85	0.63	(16.0)	0.68	(17.3)
4.89	(124.0)	88	0.64	(16.5)	0.67	(17.0)
4.87	(123.5)	91	0.65	(16.5)	0.66	(16.8)
4.85	(123.0)	94	0.66	(17.0)	0.65	(16.5)
4.83	(122.5)	97	0.67	(17.0)	0.64	(16.3)
4.81	(122.0)	100	0.68	(17.5)	0.63	(16.0)
4.79	(121.5)	103	0.69	(17.5)	0.62	(15.7)
4.77	(121.0)	106	0.70	(18.0)	0.61	(15.5)
4.75	(120.5)	109	0.71	(18.0)	0.60	(15.2)
4.73	(120.0)	112	0.72	(18.5)	0.59	(15.0)
4.71	(119.5)	115	0.73	(18.5)	0.58	(14.7)
4.69	(119.0)	118	0.74	(19.0)	0.57	(14.5)
4.67	(118.5)	121	0.75	(19.0)	0.56	(14.2)

1 Flange diameter is 6.18 in. (157 mm)

2 Wear Chart: 5203

Track Rollers <sup>(1) (2)</sup>  
Small Track Roller Flange

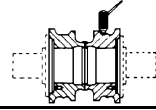
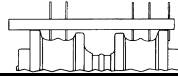
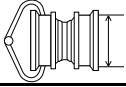

Caliper			Depth Gauge		Ultrasonic	
Inches	(mm)	% Worn	Inches	(mm)	Inches	(mm)
4.72	(120.0)	0	0.47	(12.0)	1.49	(37.8)
4.70	(119.5)	5	0.48	(12.0)	1.48	(37.6)
4.68	(119.0)	10	0.49	(12.5)	1.47	(37.3)
4.66	(118.5)	15	0.50	(12.5)	1.46	(37.1)
4.64	(118.0)	20	0.51	(13.0)	1.45	(36.8)
4.62	(117.5)	25	0.52	(13.0)	1.44	(36.6)
4.60	(117.0)	30	0.53	(13.5)	1.43	(36.3)
4.58	(116.5)	35	0.54	(13.5)	1.42	(36.1)
4.56	(116.0)	40	0.55	(14.0)	1.41	(35.8)
4.54	(115.5)	45	0.56	(14.0)	1.40	(35.6)
4.52	(115.0)	50	0.57	(14.5)	1.39	(35.3)
4.50	(114.5)	55	0.58	(14.5)	1.38	(35.1)
4.48	(114.0)	60	0.59	(15.0)	1.37	(34.8)
4.46	(113.5)	64	0.60	(15.0)	1.36	(34.5)
4.44	(113.0)	67	0.61	(15.5)	1.35	(34.3)
4.42	(112.5)	70	0.62	(15.5)	1.34	(34.0)
4.40	(112.0)	73	0.63	(16.0)	1.33	(33.8)
4.38	(111.5)	76	0.64	(16.5)	1.32	(33.5)
4.36	(110.5)	79	0.65	(16.5)	1.31	(33.3)
4.34	(110.0)	82	0.66	(17.0)	1.30	(33.0)
4.32	(109.5)	85	0.67	(17.0)	1.29	(32.8)
4.30	(109.0)	88	0.68	(17.5)	1.28	(32.5)
4.28	(108.5)	91	0.69	(17.5)	1.27	(32.3)
4.26	(108.0)	94	0.70	(18.0)	1.26	(32.0)
4.24	(107.5)	97	0.71	(18.0)	1.25	(31.8)
4.22	(107.0)	100	0.72	(18.5)	1.24	(31.5)
4.20	(106.5)	103	0.73	(18.5)	1.23	(31.2)
4.18	(106.0)	106	0.74	(19.0)	1.22	(31.0)
4.16	(105.5)	109	0.75	(19.0)	1.21	(30.7)
4.14	(105.0)	112	0.76	(19.5)	1.20	(30.5)
4.12	(104.5)	115	0.77	(19.5)	1.19	(30.2)
4.10	(104.0)	118	0.78	(20.0)	1.18	(30.0)
4.08	(103.5)	121	0.79	(20.0)	1.17	(29.7)

1 Flange diameter is 5.67 in. (144 mm)  
2 Wear Chart: 5202

# AP650, AP1050, BG225, BG245 — 6.125 in. (155.6 mm)

## Track Links <sup>(1)</sup> 6Y-0935 & 36

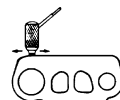
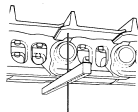

### Depth Gauge

### Ultrasonic

Depth Gauge		% Worn	Ultrasonic	
Inches	(mm)		Inches	(mm)
3.46	(88.0)	0	1.00	(25.4)
3.44	(87.5)	13	0.98	(24.9)
3.42	(87.0)	26	0.96	(24.4)
3.40	(86.5)	39	0.94	(23.9)
3.38	(86.0)	52	0.92	(23.4)
3.36	(85.5)	65	0.90	(22.9)
3.34	(85.0)	78	0.88	(22.4)
3.32	(84.5)	90	0.86	(21.8)
3.30	(84.0)	100	0.84	(21.3)
3.28	(83.5)	110	0.82	(20.8)
3.26	(83.0)	120	0.80	(20.3)

# AP650, AP1050, BG225, BG245 — 6.125 in. (155.6 mm)

## Bushings <sup>(1)</sup> External Wear Sealed & Lubricated Track

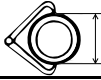

**Caliper**



**Ultrasonic**

Inches	(mm)	% Worn	Inches	(mm)
1.97	(50.0)	0	0.40	(10.2)
1.96	(49.8)	5	0.39	(9.9)
1.95	(49.5)	10	0.38	(9.7)
1.94	(49.3)	15	0.37	(9.4)
1.93	(49.0)	20	0.36	(9.1)
1.92	(48.8)	25	0.35	(8.9)
1.91	(48.5)	30	0.34	(8.6)
1.90	(48.3)	35	0.33	(8.4)
1.89	(48.0)	40	0.32	(8.1)
1.88	(47.8)	45	0.31	(7.9)
1.87	(47.5)	50	0.30	(7.6)
1.86	(47.2)	55	0.29	(7.4)
1.85	(47.0)	60	0.28	(7.1)
1.84	(46.7)	65	0.27	(6.9)
1.83	(46.5)	70	0.26	(6.6)
1.82	(46.2)	72	0.25	(6.4)
1.81	(46.0)	74	0.24	(6.1)
1.80	(45.7)	76	0.23	(5.8)
1.79	(45.5)	78	0.22	(5.6)
1.78	(45.2)	80	0.21	(5.3)
1.77	(45.0)	82	0.20	(5.1)
1.76	(44.7)	84	0.19	(4.8)
1.75	(44.5)	86	0.18	(4.6)
1.74	(44.2)	88	0.17	(4.3)
1.73	(43.9)	90	0.16	(4.1)
1.72	(43.7)	92	0.15	(3.8)
1.71	(43.4)	94	0.14	(3.6)
1.70	(43.2)	96	0.13	(3.3)
1.69	(42.9)	98	0.12	(3.0)
1.68	(42.7)	100	0.11	(2.8)
1.67	(42.4)	102	0.10	(2.5)
1.66	(42.2)	104	0.09	(2.3)
1.65	(41.9)	106	0.08	(2.0)
1.64	(41.7)	108	0.07	(1.8)
1.63	(41.4)	110	0.06	(1.5)
1.62	(41.1)	112	0.05	(1.3)
1.61	(40.9)	114	0.04	(1.0)
1.60	(40.6)	116	0.03	(0.8)
1.59	(40.4)	118	0.02	(0.5)
1.58	(40.1)	120	0.01	(0.3)

**AP650, AP1050, BG225, BG245 — 6.125 in. (155.6 mm)**

**Pins and Bushings <sup>(1)</sup>  
Internal Wear  
Sealed Track**

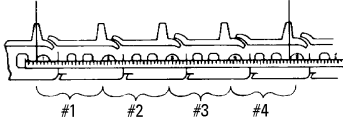

<b>Inches</b>	<b>(mm)</b>	<b>% Worn</b>
24.55	(623.5)	0
24.60	(625.0)	10
24.65	(626.0)	20
24.70	(627.5)	30
24.75	(628.5)	40
24.80	(630.0)	50
24.85	(631.0)	60
24.90	(632.5)	70
24.95	(633.5)	80
25.00	(635.0)	90
25.05	(636.5)	100
25.10	(637.5)	105
25.15	(639.0)	110
25.20	(640.0)	115
25.25	(641.5)	120

1 Wear Chart: 320



# AP650, AP1050, BG225, BG245 — 6.125 in. (155.6 mm)

## Bushings <sup>(1)</sup> External Wear Sealed Track

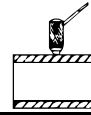

Caliper		Allowable Wear			
		Lesser	Greater	Ultrasonic	
Inches	(mm)	% Worn	% Worn	Inches	(mm)
1.97	(50.0)	0	0	0.40	(10.2)
1.96	(49.8)	8	6	0.39	(9.9)
1.95	(49.5)	16	12	0.38	(9.7)
1.94	(49.3)	24	18	0.37	(9.4)
1.93	(49.0)	32	24	0.36	(9.1)
1.92	(48.8)	40	30	0.35	(8.9)
1.91	(48.5)	48	36	0.34	(8.6)
1.90	(48.3)	56	42	0.33	(8.4)
1.89	(48.0)	64	48	0.32	(8.1)
1.88	(47.8)	72	54	0.31	(7.9)
1.87	(47.5)	76	60	0.30	(7.6)
1.86	(47.2)	80	64	0.29	(7.4)
1.85	(47.0)	84	67	0.28	(7.1)
1.84	(46.7)	88	70	0.27	(6.9)
1.83	(46.5)	92	73	0.26	(6.6)
1.82	(46.2)	96	76	0.25	(6.4)
1.81	(46.0)	100	79	0.24	(6.1)
1.80	(45.7)	104	82	0.23	(5.8)
1.79	(45.5)	108	85	0.22	(5.6)
1.78	(45.2)	112	88	0.21	(5.3)
1.77	(45.0)	116	91	0.20	(5.1)
1.76	(44.7)	120	94	0.19	(4.8)
1.75	(44.5)		97	0.18	(4.6)
1.74	(44.2)		100	0.17	(4.3)
1.73	(43.9)		103	0.16	(4.1)
1.72	(43.7)		106	0.15	(3.8)
1.71	(43.4)		109	0.14	(3.6)
1.70	(43.2)		112	0.13	(3.3)
1.69	(42.9)		115	0.12	(3.0)
1.68	(42.7)		118	0.11	(2.8)
1.67	(42.4)		121	0.10	(2.5)

**AP650, AP1050, BG225, BG245 — 6.125 in. (155.6 mm)**

**Track Shoes <sup>(1)</sup>  
Triple Grouser**

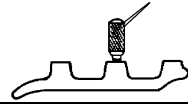
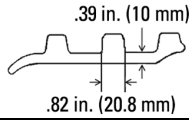
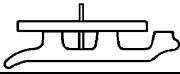

**Depth Gauge**

**Ultrasonic**

<b>Inches</b>	<b>(mm)</b>	<b>% Worn</b>	<b>Inches</b>	<b>(mm)</b>
0.60	(15.0)	0	1.00	(25.4)
0.55	(14.0)	15	0.95	(24.1)
0.50	(12.5)	30	0.90	(22.9)
0.45	(11.5)	44	0.85	(21.6)
0.40	(10.0)	58	0.80	(20.3)
0.35	(9.0)	72	0.75	(19.1)
0.30	(7.5)	86	0.70	(17.8)
0.25	(6.5)	100	0.65	(16.5)
0.20	(5.0)	114	0.60	(15.2)
0.15	(4.0)	128	0.55	(14.0)

1 Wear Chart: 2720

# AP650, AP1050, BG225, BG245 — 6.125 in. (155.6 mm)

**Track Shoes <sup>(1)</sup>  
Rubber Grouser**

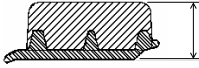

**Depth Gauge**

Inches	(mm)	% Worn
1.99	(50.5)	0
1.94	(49.5)	8
1.89	(48.0)	16
1.84	(46.5)	24
1.79	(45.5)	32
1.74	(44.0)	40
1.69	(43.0)	48
1.64	(41.5)	56
1.59	(40.5)	64
1.54	(39.0)	72
1.49	(38.0)	79
1.44	(36.5)	86
1.39	(35.5)	93
1.34	(34.0)	100
1.29	(33.0)	107
1.24	(31.5)	114
1.19	(30.0)	121

**NOTE**

Measure from the top of the grouser pad to the bottom of the mounting plate.

# AP650, AP1050, BG225, BG245 — 6.125 in. (155.6 mm)

Idler (1) (2) (3)

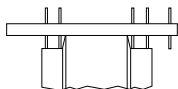

Depth Gauge

Inches	(mm)	% Worn
0.62	(15.5)	0
0.64	(16.5)	12
0.66	(17.0)	24
0.68	(17.5)	36
0.70	(18.0)	48
0.72	(18.5)	60
0.74	(19.0)	68
0.76	(19.5)	76
0.78	(20.0)	84
0.80	(20.5)	92
0.82	(21.0)	100
0.84	(21.5)	108
0.86	(22.0)	116
0.88	(22.5)	124

- 1 Flange width is 1.96 in. (49.73 mm)
- 2 New tread diameter is 12.00 in. (304.8 mm)
- 3 Wear Chart: 4348

**AP650, AP1050, BG225, BG245 — 6.125 in. (155.6 mm)**

**Carrier Rollers <sup>(1)</sup>**

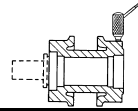
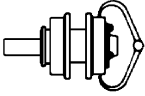

Caliper			Ultrasonic	
Inches	(mm)	% Worn	Inches	(mm)
5.88	(149.5)	0	1.38	(35.1)
5.84	(148.5)	9	1.36	(34.5)
5.80	(147.5)	18	1.34	(34.0)
5.76	(146.5)	27	1.32	(33.5)
5.72	(145.5)	36	1.30	(33.0)
5.68	(144.5)	45	1.28	(32.5)
5.64	(143.5)	54	1.26	(32.0)
5.60	(142.0)	63	1.24	(31.5)
5.56	(141.0)	70	1.22	(31.0)
5.52	(140.0)	76	1.20	(30.5)
5.48	(139.0)	82	1.18	(30.0)
5.44	(138.0)	88	1.16	(29.5)
5.40	(137.0)	94	1.14	(29.0)
5.36	(136.0)	100	1.12	(28.4)
5.32	(135.0)	106	1.10	(27.9)
5.28	(134.0)	115	1.08	(27.4)
5.24	(133.0)	118	1.06	(26.9)
5.20	(132.0)	124	1.04	(26.4)

# AP650, AP1050, BG225, BG245 — 6.125 in. (155.6 mm)

## Track Rollers <sup>(1) (2)</sup> Large Diameter Front Rollers

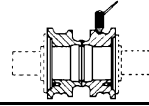
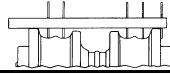

Caliper		% Worn	Depth Gauge		Ultrasonic	
Inches	(mm)		Inches	(mm)	Inches	(mm)
9.50	(241.5)	0	0.84	(21.5)	2.43	(61.7)
9.48	(241.0)	6	0.85	(21.5)	2.42	(61.5)
9.46	(240.5)	12	0.86	(22.0)	2.41	(61.2)
9.44	(240.0)	18	0.87	(22.0)	2.40	(61.0)
9.42	(239.5)	24	0.88	(22.5)	2.39	(60.7)
9.40	(238.0)	30	0.89	(22.5)	2.38	(60.5)
9.38	(238.5)	36	0.90	(23.0)	2.37	(60.2)
9.36	(237.5)	42	0.91	(23.0)	2.36	(59.9)
9.34	(237.0)	48	0.92	(23.5)	2.35	(59.7)
9.32	(236.5)	54	0.93	(23.5)	2.34	(59.4)
9.30	(236.0)	60	0.94	(24.0)	2.33	(59.2)
9.28	(235.5)	65	0.95	(24.0)	2.32	(58.9)
9.26	(235.0)	70	0.96	(24.5)	2.31	(58.7)
9.24	(234.5)	75	0.97	(24.5)	2.30	(58.4)
9.22	(234.0)	80	0.98	(25.0)	2.29	(58.2)
9.20	(233.5)	85	0.99	(25.0)	2.28	(57.9)
9.18	(233.0)	90	1.00	(25.5)	2.27	(57.7)
9.16	(232.5)	95	1.01	(25.5)	2.26	(57.4)
9.14	(232.0)	100	1.02	(26.0)	2.25	(57.2)
9.12	(231.5)	105	1.03	(26.0)	2.24	(56.9)
9.10	(231.0)	110	1.04	(26.5)	2.23	(56.6)
9.08	(230.5)	115	1.05	(26.5)	2.22	(56.4)
9.06	(230.0)	120	1.06	(27.0)	2.21	(56.1)

**NOTE:** Refer to the chart below for various Track Roller Sequence and wear chart.

Model	Rollers		Roller Position							
	Per Side		F	2	3	4	5	6	7	8
AP650	7		S <sup>L</sup>	S <sup>L</sup>	S <sup>L</sup>	S <sup>L</sup>	S <sup>L</sup>	S <sup>S</sup>	S <sup>S</sup>	
AP1050	7		S <sup>L</sup>	S <sup>L</sup>	S <sup>L</sup>	S <sup>L</sup>	S <sup>L</sup>	S <sup>L</sup>	N <sup>F</sup>	
AP1050B	8		S <sup>L</sup>	S <sup>L</sup>	S <sup>L</sup>	S <sup>L</sup>	S <sup>S</sup>	S <sup>S</sup>	S <sup>S</sup>	S <sup>S</sup>
BG225	7		S <sup>L</sup>	S <sup>L</sup>	S <sup>L</sup>	S <sup>L</sup>	S <sup>S</sup>	S <sup>S</sup>	S <sup>S</sup>	
BG245	8		S <sup>L</sup>	S <sup>L</sup>	S <sup>L</sup>	S <sup>L</sup>	S <sup>S</sup>	S <sup>S</sup>	S <sup>S</sup>	S <sup>S</sup>

Key:

S<sup>L</sup> – Large diameter front roller, [see, page 756](#)

S<sup>S</sup> – Small diameter rear roller, [see, page 757](#)

N<sup>F</sup> – No flange rear roller, [see, page 758](#)

**NOTE:** [Computerized CTS, page 81](#) will only determine percent worn for the large diameter front rollers.

1 Flange diameter is 11.2 in. (284.4 mm)

2 Wear Chart: 5223

# AP650, AP1050, BG225, BG245 — 6.125 in. (155.6 mm)

## Track Rollers <sup>(1) (2)</sup> Small Diameter Rear Rollers

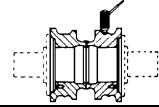
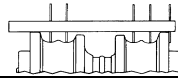
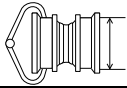

Caliper			Depth Gauge		Ultrasonic	
Inches	(mm)	% Worn	Inches	(mm)	Inches	(mm)
6.00	(152.5)	0	0.43	(11.0)	1.43	(36.3)
5.97	(151.5)	4	0.45	(11.5)	1.42	(35.9)
5.94	(151.0)	8	0.46	(11.5)	1.40	(35.6)
5.91	(150.0)	12	0.48	(12.0)	1.39	(35.2)
5.88	(149.5)	16	0.49	(12.5)	1.37	(34.8)
5.85	(148.5)	20	0.51	(13.0)	1.36	(34.4)
5.82	(148.0)	24	0.52	(13.0)	1.34	(34.0)
5.79	(147.0)	28	0.54	(13.5)	1.33	(33.7)
5.76	(146.5)	32	0.55	(14.0)	1.31	(33.3)
5.73	(145.5)	36	0.57	(14.5)	1.30	(32.9)
5.70	(145.0)	40	0.58	(14.5)	1.28	(32.5)
5.67	(144.0)	44	0.60	(15.0)	1.27	(32.1)
5.64	(143.5)	48	0.61	(15.5)	1.25	(31.8)
5.61	(142.5)	52	0.63	(16.0)	1.24	(31.4)
5.58	(141.5)	56	0.64	(16.5)	1.22	(31.0)
5.55	(141.0)	60	0.66	(16.5)	1.21	(30.6)
5.52	(140.0)	64	0.67	(17.0)	1.19	(30.2)
5.49	(139.5)	68	0.69	(17.5)	1.18	(29.8)
5.46	(138.5)	72	0.70	(18.0)	1.16	(29.5)
5.43	(138.0)	76	0.72	(18.0)	1.15	(29.1)
5.40	(137.0)	80	0.73	(18.5)	1.13	(28.7)
5.37	(136.5)	84	0.75	(19.0)	1.12	(28.3)
5.34	(135.5)	88	0.76	(19.5)	1.10	(27.9)
5.31	(135.0)	91	0.78	(19.5)	1.09	(27.6)
5.28	(134.0)	94	0.79	(20.0)	1.07	(27.2)
5.25	(133.5)	97	0.81	(20.5)	1.06	(26.8)
5.22	(132.5)	100	0.82	(21.0)	1.04	(26.4)
5.19	(132.0)	103	0.84	(21.0)	1.03	(26.0)
5.16	(131.0)	106	0.85	(21.5)	1.01	(25.7)
5.13	(130.5)	109	0.87	(22.0)	1.00	(25.3)
5.10	(129.5)	112	0.88	(22.5)	0.98	(24.9)
5.07	(129.0)	115	0.90	(22.5)	0.97	(24.5)
5.04	(128.0)	118	0.91	(23.0)	0.95	(24.1)
5.01	(127.5)	121	0.93	(23.5)	0.94	(23.7)

1 Flange diameter is 6.88 in. (174.6 mm)

2 Wear Chart: 5222

# AP1050 — 6.125 in. (155.6 mm)

## Track Rollers <sup>(1)</sup> Rear Track Roller without Flange Use on AP-1050 only

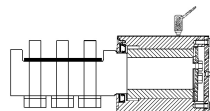
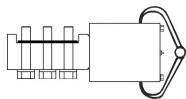

Caliper			Ultrasonic		
Inches	(mm)	% Worn	Inches	(mm)	
6.50	(165.0)	0	1.12	(28.4)	
6.48	(164.5)	4	1.11	(28.2)	
6.46	(164.0)	8	1.10	(27.9)	
6.44	(163.5)	12	1.09	(27.7)	
6.42	(163.0)	16	1.08	(27.4)	
6.40	(162.5)	20	1.07	(27.2)	
6.38	(162.0)	24	1.06	(26.9)	
6.36	(161.5)	28	1.05	(26.7)	
6.34	(161.0)	32	1.04	(26.4)	
6.32	(160.5)	36	1.03	(26.2)	
6.30	(160.0)	40	1.02	(25.9)	
6.28	(159.5)	44	1.01	(25.7)	
6.26	(159.0)	48	1.00	(25.4)	
6.24	(158.5)	52	0.99	(25.1)	
6.22	(158.0)	56	0.98	(24.9)	
6.20	(157.5)	60	0.97	(24.6)	
6.18	(157.0)	64	0.96	(24.4)	
6.16	(156.5)	68	0.95	(24.1)	
6.14	(156.0)	72	0.94	(23.9)	
6.12	(155.5)	76	0.93	(23.6)	
6.10	(155.0)	80	0.92	(23.4)	
6.08	(154.5)	84	0.91	(23.1)	
6.06	(154.0)	88	0.90	(22.9)	
6.04	(153.5)	92	0.89	(22.6)	
6.02	(153.0)	96	0.88	(22.4)	
6.00	(152.5)	100	0.87	(22.1)	
5.98	(152.0)	104	0.86	(21.8)	
5.96	(151.5)	108	0.85	(21.6)	
5.94	(151.0)	112	0.84	(21.3)	
5.92	(150.5)	116	0.83	(21.1)	
5.90	(150.0)	120	0.82	(20.8)	

1 Wear Chart: 5224



# SF250B, TR225B, PR450, SF350 — 6.125 in. (155.6 mm)

## Track Links <sup>(1)</sup> 6Y-0935 & 36

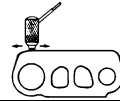
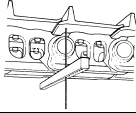

Depth Gauge			Ultrasonic	
Inches	(mm)	% Worn	Inches	(mm)
3.46	(88.0)	0	1.00	(25.4)
3.44	(87.5)	8	0.98	(24.9)
3.42	(87.0)	16	0.96	(24.4)
3.40	(86.5)	24	0.94	(23.9)
3.38	(86.0)	32	0.92	(23.4)
3.36	(85.5)	40	0.90	(22.9)
3.34	(85.0)	48	0.88	(22.4)
3.32	(84.5)	56	0.86	(21.8)
3.30	(84.0)	64	0.84	(21.3)
3.28	(83.5)	72	0.82	(20.8)
3.26	(83.0)	80	0.80	(20.3)
3.24	(82.5)	88	0.78	(19.8)
3.22	(82.0)	94	0.76	(19.3)
3.20	(81.5)	100	0.74	(18.8)
3.18	(81.0)	106	0.72	(18.3)
3.16	(80.5)	112	0.70	(17.8)
3.14	(80.0)	118	0.68	(17.3)
3.12	(79.0)	124	0.66	(16.8)

**AP650, AP1050, BG225, BG245 — 6.125 in. (155.6 mm)**

**Pins and Bushings <sup>(1)</sup>  
Internal Wear  
Sealed Track**

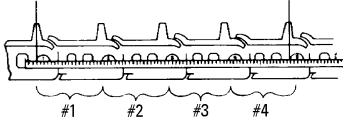

<b>Inches</b>	<b>(mm)</b>	<b>% Worn</b>
24.55	(623.5)	0
24.60	(625.0)	10
24.65	(626.0)	20
24.70	(627.5)	30
24.75	(628.5)	40
24.80	(630.0)	50
24.85	(631.0)	60
24.90	(632.5)	70
24.95	(633.5)	80
25.00	(635.0)	90
25.05	(636.5)	100
25.10	(637.5)	105
25.15	(639.0)	110
25.20	(640.0)	115
25.25	(641.5)	120

1 Wear Chart: 320

# AP650, AP1050, BG225, BG245 — 6.125 in. (155.6 mm)

## Bushings <sup>(1)</sup> External Wear Sealed Track

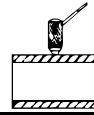

Allowable Wear					
Caliper		Lesser	Greater	Ultrasonic	
Inches	(mm)	% Worn	% Worn	Inches	(mm)
1.97	(50.0)	0	0	0.40	(10.2)
1.96	(49.8)	8	6	0.39	(9.9)
1.95	(49.5)	16	12	0.38	(9.7)
1.94	(49.3)	24	18	0.37	(9.4)
1.93	(49.0)	32	24	0.36	(9.1)
1.92	(48.8)	40	30	0.35	(8.9)
1.91	(48.5)	48	36	0.34	(8.6)
1.90	(48.3)	56	42	0.33	(8.4)
1.89	(48.0)	64	48	0.32	(8.1)
1.88	(47.8)	72	54	0.31	(7.9)
1.87	(47.5)	76	60	0.30	(7.6)
1.86	(47.2)	80	64	0.29	(7.4)
1.85	(47.0)	84	67	0.28	(7.1)
1.84	(46.7)	88	70	0.27	(6.9)
1.83	(46.5)	92	73	0.26	(6.6)
1.82	(46.2)	96	76	0.25	(6.4)
1.81	(46.0)	100	79	0.24	(6.1)
1.80	(45.7)	104	82	0.23	(5.8)
1.79	(45.5)	108	85	0.22	(5.6)
1.78	(45.2)	112	88	0.21	(5.3)
1.77	(45.0)	116	91	0.20	(5.1)
1.76	(44.7)	120	94	0.19	(4.8)
1.75	(44.5)		97	0.18	(4.6)
1.74	(44.2)		100	0.17	(4.3)
1.73	(43.9)		103	0.16	(4.1)
1.72	(43.7)		106	0.15	(3.8)
1.71	(43.4)		109	0.14	(3.6)
1.70	(43.2)		112	0.13	(3.3)
1.69	(42.9)		115	0.12	(3.0)
1.68	(42.7)		118	0.11	(2.8)
1.67	(42.4)		121	0.10	(2.5)

# AP650, AP1050, BG225, BG245 — 6.125 in. (155.6 mm)

## Track Shoes <sup>(1)</sup> Triple Grouser

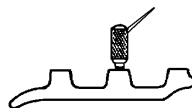
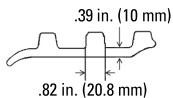
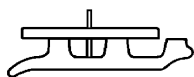

Depth Gauge			Ultrasonic	
Inches	(mm)	% Worn	Inches	(mm)
0.60	(15.0)	0	1.00	(25.4)
0.55	(14.0)	15	0.95	(24.1)
0.50	(12.5)	30	0.90	(22.9)
0.45	(11.5)	44	0.85	(21.6)
0.40	(10.0)	58	0.80	(20.3)
0.35	(9.0)	72	0.75	(19.1)
0.30	(7.5)	86	0.70	(17.8)
0.25	(6.5)	100	0.65	(16.5)
0.20	(5.0)	114	0.60	(15.2)
0.15	(4.0)	128	0.55	(14.0)

1 Wear Chart: 2720

Track Shoes <sup>(1)</sup>  
Rubber Grouser

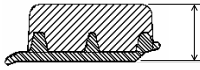

Depth Gauge

Inches	(mm)	% Worn
1.99	(50.5)	0
1.94	(49.5)	8
1.89	(48.0)	16
1.84	(46.5)	24
1.79	(45.5)	32
1.74	(44.0)	40
1.69	(43.0)	48
1.64	(41.5)	56
1.59	(40.5)	64
1.54	(39.0)	72
1.49	(38.0)	79
1.44	(36.5)	86
1.39	(35.5)	93
1.34	(34.0)	100
1.29	(33.0)	107
1.24	(31.5)	114
1.19	(30.0)	121

NOTE

Measure from the top of the grouser pad to the bottom of the mounting plate.

**SF250B, TR225B, PR450, SF350 — 6.125 in. (155.6 mm)**

**Idlers** <sup>(1)</sup> <sup>(2)</sup> <sup>(3)</sup>

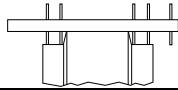

**Depth Gauge**

Inches	(mm)	% Worn
0.62	(15.5)	0
0.64	(16.5)	12
0.66	(17.0)	24
0.68	(17.5)	36
0.70	(18.0)	48
0.72	(18.5)	60
0.74	(19.0)	68
0.76	(19.5)	76
0.78	(20.0)	84
0.80	(20.5)	92
0.82	(21.0)	100
0.84	(21.5)	108
0.86	(22.0)	116
0.88	(22.5)	124

**NOTE**

On earlier, single web idlers the manufacturing process erroneously permitted a crowned center flange. When measuring earlier, single web idlers with a crown, subtract .10 in. (2.4 mm) from the actual wear measurement when determining percent worn. Reference: IRM UC92-23.

- 1 Flange width is 2.11 in. (53.5 mm)
- 2 New tread diameter is 20.28 in. (515.0 mm)
- 3 Wear Chart: 4320

# SF250B, TR225B, PR450, SF350 — 6.125 in. (155.6 mm)

## Track Rollers <sup>(1)</sup> <sup>(2)</sup>

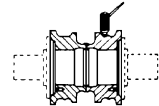
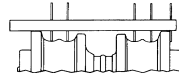
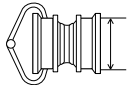

Caliper			Depth Gauge		Ultrasonic	
Inches	(mm)	% Worn	Inches	(mm)	Inches	(mm)
6.00	(152.5)	0	0.43	(11.0)	1.43	(36.3)
5.97	(151.5)	4	0.45	(11.5)	1.42	(35.9)
5.94	(151.0)	8	0.46	(11.5)	1.40	(35.6)
5.91	(150.0)	12	0.48	(12.0)	1.39	(35.2)
5.88	(149.5)	16	0.49	(12.5)	1.37	(34.8)
5.85	(148.5)	20	0.51	(13.0)	1.36	(34.4)
5.82	(148.0)	24	0.52	(13.0)	1.34	(34.0)
5.79	(147.0)	28	0.54	(13.5)	1.33	(33.7)
5.76	(146.5)	32	0.55	(14.0)	1.31	(33.3)
5.73	(145.5)	36	0.57	(14.5)	1.30	(32.9)
5.70	(145.0)	40	0.58	(14.5)	1.28	(32.5)
5.67	(144.0)	44	0.60	(15.0)	1.27	(32.1)
5.64	(143.5)	48	0.61	(15.5)	1.25	(31.8)
5.61	(142.5)	52	0.63	(16.0)	1.24	(31.4)
5.58	(141.5)	56	0.64	(16.5)	1.22	(31.0)
5.55	(141.0)	60	0.66	(16.5)	1.21	(30.6)
5.52	(140.0)	64	0.67	(17.0)	1.19	(30.2)
5.49	(139.5)	68	0.69	(17.5)	1.18	(29.8)
5.46	(138.5)	72	0.70	(18.0)	1.16	(29.5)
5.43	(138.0)	76	0.72	(18.0)	1.15	(29.1)
5.40	(137.0)	80	0.73	(18.5)	1.13	(28.7)
5.37	(136.5)	84	0.75	(19.0)	1.12	(28.3)
5.34	(135.5)	88	0.76	(19.5)	1.10	(27.9)
5.31	(135.0)	91	0.78	(19.5)	1.09	(27.6)
5.28	(134.0)	94	0.79	(20.0)	1.07	(27.2)
5.25	(133.5)	97	0.81	(20.5)	1.06	(26.8)
5.22	(132.5)	100	0.82	(21.0)	1.04	(26.4)
5.19	(132.0)	103	0.84	(21.0)	1.03	(26.0)
5.16	(131.0)	106	0.85	(21.5)	1.01	(25.7)
5.13	(130.5)	109	0.87	(22.0)	1.00	(25.3)
5.10	(129.5)	112	0.88	(22.5)	0.98	(24.9)
5.07	(129.0)	115	0.90	(22.5)	0.97	(24.5)
5.04	(128.0)	118	0.91	(23.0)	0.95	(24.1)
5.01	(127.5)	121	0.93	(23.5)	0.94	(23.7)

1 Flange diameter is 6.88 in. (175 mm)

2 Wear Chart: 5222

**PR750, PR1000, SF500, SF550, TR500 — 6.75 in. (171.5 mm)**

**Track Links <sup>(1)</sup>  
9K-6628 & 29**

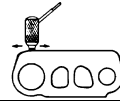
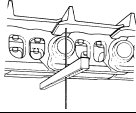

Depth Gauge			Ultrasonic	
Inches	(mm)	% Worn	Inches	(mm)
3.75	(95.5)	0	1.00	(25.4)
3.73	(94.5)	8	0.98	(24.9)
3.71	(94.0)	16	0.96	(24.4)
3.69	(93.5)	24	0.94	(23.9)
3.67	(93.0)	32	0.92	(23.4)
3.65	(92.5)	40	0.90	(22.9)
3.63	(92.0)	46	0.88	(22.4)
3.61	(91.5)	52	0.86	(21.8)
3.59	(91.0)	58	0.84	(21.3)
3.57	(90.5)	64	0.82	(20.8)
3.55	(90.0)	70	0.80	(20.3)
3.53	(89.5)	76	0.78	(19.8)
3.51	(89.0)	82	0.76	(19.3)
3.49	(88.5)	88	0.74	(18.8)
3.47	(88.0)	94	0.72	(18.3)
3.45	(87.5)	100	0.70	(17.8)
3.43	(87.0)	106	0.68	(17.3)
3.41	(86.5)	112	0.66	(16.8)
3.39	(86.0)	118	0.64	(16.3)
3.37	(85.5)	124	0.62	(15.7)



**PR750, PR1000, SF500, SF550, TR500 — 6.75 in. (171.5 mm)**

**Pins and Bushings <sup>(1)</sup>  
Internal Wear  
Sealed Track**

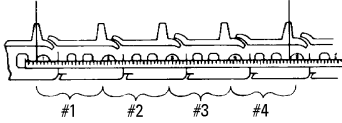

Inches	(mm)	% Worn
27.00	(686.0)	0
27.05	(687.0)	10
27.10	(688.5)	20
27.15	(689.5)	30
27.20	(691.0)	40
27.25	(692.0)	50
27.30	(693.5)	60
27.35	(694.5)	70
27.40	(696.0)	80
27.45	(697.0)	90
27.50	(698.5)	100
27.55	(700.0)	105
27.60	(701.0)	110
27.65	(702.5)	115
27.70	(703.5)	120

**PR750, PR1000, SF500, SF550, TR500 — 6.75 in. (171.5 mm)**

**Bushings <sup>(1)</sup>  
External Wear  
Sealed Track**

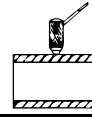

Caliper		Allowable Wear		Ultrasonic	
Inches	(mm)	Lesser % Worn	Greater % Worn	Inches	(mm)
2.14	(54.4)	0	0	0.39	(9.9)
2.13	(54.1)	9	7	0.38	(9.7)
2.12	(53.8)	18	14	0.37	(9.4)
2.11	(53.6)	27	21	0.36	(9.1)
2.10	(53.3)	36	28	0.35	(8.9)
2.09	(53.1)	45	35	0.34	(8.6)
2.08	(52.8)	54	42	0.33	(8.4)
2.07	(52.6)	63	49	0.32	(8.1)
2.06	(52.3)	72	56	0.31	(7.9)
2.05	(52.1)	81	63	0.30	(7.6)
2.04	(51.8)	88	70	0.29	(7.4)
2.03	(51.6)	92	73	0.28	(7.1)
2.02	(51.3)	96	76	0.27	(6.9)
2.01	(51.1)	100	79	0.26	(6.6)
2.00	(50.8)	104	82	0.25	(6.4)
1.99	(50.5)	108	85	0.24	(6.1)
1.98	(50.3)	112	88	0.23	(5.8)
1.97	(50.0)	116	91	0.22	(5.6)
1.96	(49.8)	120	94	0.21	(5.3)
1.95	(49.5)		97	0.20	(5.1)
1.94	(49.3)		100	0.19	(4.8)
1.93	(49.0)		103	0.18	(4.6)
1.92	(48.8)		106	0.17	(4.3)
1.91	(48.5)		109	0.16	(4.1)
1.90	(48.3)		112	0.15	(3.8)
1.89	(48.0)		115	0.14	(3.6)
1.88	(47.8)		118	0.13	(3.3)
1.87	(47.5)		121	0.2	(3.0)

1 Wear Chart: 942

**PR750, PR1000, SF500, SF550, TR500 — 6.75 in. (171.5 mm)**

**Track Shoes <sup>(1)</sup>  
Triple Grouser**

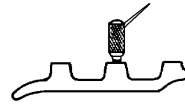
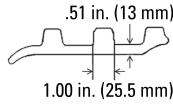
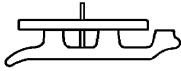

**Depth Gauge**

**Ultrasonic**

Inches	(mm)	% Worn	Inches	(mm)
0.95	(24.0)	0	1.50	(38.1)
0.90	(23.0)	8	1.45	(36.8)
0.85	(21.5)	16	1.40	(35.6)
0.80	(20.5)	23	1.35	(34.3)
0.75	(19.0)	30	1.30	(33.0)
0.70	(18.0)	37	1.25	(31.8)
0.65	(16.5)	44	1.20	(30.5)
0.60	(15.0)	51	1.15	(29.2)
0.55	(14.0)	58	1.10	(27.9)
0.50	(12.5)	65	1.05	(26.7)
0.45	(11.5)	72	1.00	(25.4)
0.40	(10.0)	79	0.95	(24.1)
0.35	(9.0)	86	0.90	(22.9)
0.30	(7.5)	93	0.85	(21.6)
0.25	(6.5)	100	0.80	(20.3)
0.20	(5.0)	107	0.75	(19.1)
0.15	(4.0)	114	0.70	(17.8)
0.10	(2.5)	121	0.65	(16.5)

**PR750, PR1000, SF500, SF550, TR500 — 6.75 in. (171.5 mm)**

**Carrier Rollers <sup>(1)</sup>**

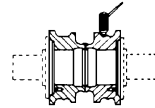
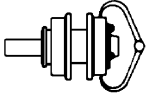

Caliper			Ultrasonic	
Inches	(mm)	% Worn	Inches	(mm)
6.26	(159.0)	0	1.63	(41.4)
6.22	(158.0)	8	1.61	(40.9)
6.18	(157.0)	16	1.59	(40.4)
6.14	(156.0)	24	1.57	(39.9)
6.10	(155.0)	32	1.55	(39.4)
6.06	(154.0)	40	1.53	(38.9)
6.02	(153.0)	45	1.51	(38.4)
5.98	(152.0)	50	1.49	(37.8)
5.94	(151.0)	55	1.47	(37.3)
5.90	(150.0)	60	1.45	(36.8)
5.86	(149.0)	65	1.43	(36.3)
5.82	(148.0)	70	1.41	(35.8)
5.78	(147.0)	75	1.39	(35.3)
5.74	(146.0)	80	1.37	(34.8)
5.70	(145.0)	85	1.35	(34.3)
5.66	(144.0)	90	1.33	(33.8)
5.62	(142.5)	95	1.31	(33.3)
5.58	(141.5)	100	1.29	(32.8)
5.54	(140.5)	105	1.27	(32.3)
5.50	(139.5)	110	1.25	(31.8)
5.46	(138.5)	115	1.23	(31.2)
5.42	(137.5)	120	1.21	(30.7)

1 Wear Chart: 4643

**PR750, PR1000, SF500, SF550, TR500 — 6.75 in. (171.5 mm)**

**Track Rollers <sup>(1)</sup> (2)**

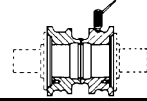
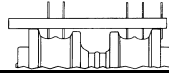

Caliper		% Worn	Depth Gauge		Ultrasonic	
Inches	(mm)		Inches	(mm)	Inches	(mm)
8.00	(203.0)	0	0.54	(13.5)	2.00	(50.8)
7.98	(202.5)	4	0.55	(14.0)	1.99	(50.5)
7.96	(202.0)	8	0.56	(14.0)	1.98	(50.3)
7.94	(201.5)	12	0.57	(14.5)	1.97	(50.0)
7.92	(201.0)	16	0.58	(14.5)	1.96	(49.8)
7.90	(200.5)	20	0.59	(15.0)	1.95	(49.5)
7.88	(200.0)	24	0.60	(15.0)	1.94	(49.3)
7.86	(199.5)	28	0.61	(15.5)	1.93	(49.0)
7.84	(199.0)	31	0.62	(15.5)	1.92	(48.8)
7.82	(198.5)	34	0.63	(16.0)	1.91	(48.5)
7.80	(198.0)	37	0.64	(16.5)	1.90	(48.3)
7.78	(197.5)	40	0.65	(16.5)	1.89	(48.0)
7.76	(197.0)	43	0.66	(17.0)	1.88	(47.8)
7.74	(196.5)	46	0.67	(17.0)	1.87	(47.5)
7.72	(196.0)	49	0.68	(17.5)	1.86	(47.2)
7.70	(195.5)	52	0.69	(17.5)	1.85	(47.0)
7.68	(195.0)	55	0.70	(18.0)	1.84	(46.7)
7.66	(194.5)	58	0.71	(18.0)	1.83	(46.5)
7.64	(194.0)	61	0.72	(18.5)	1.82	(46.2)
7.62	(193.5)	64	0.73	(18.5)	1.81	(46.0)
7.60	(193.0)	67	0.74	(19.0)	1.80	(45.7)
7.58	(192.5)	70	0.75	(19.0)	1.79	(45.5)
7.56	(192.0)	73	0.76	(19.5)	1.78	(45.2)
7.54	(191.5)	76	0.77	(19.5)	1.77	(45.0)
7.52	(191.0)	79	0.78	(20.0)	1.76	(44.7)
7.50	(190.5)	82	0.79	(20.0)	1.75	(44.5)
7.48	(190.0)	85	0.80	(20.5)	1.74	(44.2)
7.46	(189.5)	88	0.81	(20.5)	1.73	(43.9)
7.44	(189.0)	91	0.82	(21.0)	1.72	(43.7)
7.42	(188.5)	94	0.83	(21.0)	1.71	(43.4)
7.40	(188.0)	97	0.84	(21.5)	1.70	(43.2)
7.38	(187.5)	100	0.85	(21.5)	1.69	(42.9)
7.36	(187.0)	103	0.86	(22.0)	1.68	(42.7)
7.34	(186.5)	106	0.87	(22.0)	1.67	(42.4)
7.32	(186.0)	109	0.88	(22.5)	1.66	(42.2)
7.30	(185.5)	112	0.89	(22.5)	1.65	(41.9)
7.28	(185.0)	115	0.90	(23.0)	1.64	(41.7)
7.26	(184.5)	118	0.91	(23.0)	1.63	(41.4)
7.24	(184.0)	121	0.92	(23.5)	1.62	(41.1)

1 Flange diameter is 9.09 in. (231 mm)  
 2 Wear Chart: 5243

**PM565 — 6.75 in. (171.5 mm)**

**Track Links <sup>(1)</sup>  
9K-6628 & 29**

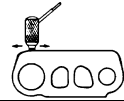
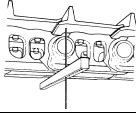

Depth Gauge			Ultrasonic	
Inches	(mm)	% Worn	Inches	(mm)
3.75	(95.5)	0	1.00	(25.4)
3.73	(94.5)	8	0.98	(24.9)
3.71	(94.0)	16	0.96	(24.4)
3.69	(93.5)	24	0.94	(23.9)
3.67	(93.0)	32	0.92	(23.4)
3.65	(92.5)	40	0.90	(22.9)
3.63	(92.0)	46	0.88	(22.4)
3.61	(91.5)	52	0.86	(21.8)
3.59	(91.0)	58	0.84	(21.3)
3.57	(90.5)	64	0.82	(20.8)
3.55	(90.0)	70	0.80	(20.3)
3.53	(89.5)	76	0.78	(19.8)
3.51	(89.0)	82	0.76	(19.3)
3.49	(88.5)	88	0.74	(18.8)
3.47	(88.0)	94	0.72	(18.3)
3.45	(87.5)	100	0.70	(17.8)
3.43	(87.0)	106	0.68	(17.3)
3.41	(86.5)	112	0.66	(16.8)
3.39	(86.0)	118	0.64	(16.3)
3.37	(85.5)	124	0.62	(15.7)

**Pins and Bushings <sup>(1)</sup>  
Internal Wear  
Sealed Track**

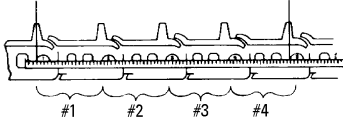

Inches	(mm)	% Worn
27.00	(686.0)	0
27.05	(687.0)	10
27.10	(688.5)	20
27.15	(689.5)	30
27.20	(691.0)	40
27.25	(692.0)	50
27.30	(693.5)	60
27.35	(694.5)	70
27.40	(696.0)	80
27.45	(697.0)	90
27.50	(698.5)	100
27.55	(700.0)	105
27.60	(701.0)	110
27.65	(702.5)	115
27.70	(703.5)	120

**PM565 — 6.75 in. (171.5 mm)**

**Bushings <sup>(1)</sup>  
External Wear  
Sealed Track**

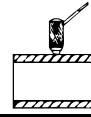

Caliper		Allowable Wear		Ultrasonic	
Inches	(mm)	Lesser % Worn	Greater % Worn	Inches	(mm)
2.14	(54.4)	0	0	0.39	(9.9)
2.13	(54.1)	9	7	0.38	(9.7)
2.12	(53.8)	18	14	0.37	(9.4)
2.11	(53.6)	27	21	0.36	(9.1)
2.10	(53.3)	36	28	0.35	(8.9)
2.09	(53.1)	45	35	0.34	(8.6)
2.08	(52.8)	54	42	0.33	(8.4)
2.07	(52.6)	63	449	0.32	(8.1)
2.06	(52.3)	72	56	0.31	(7.9)
2.05	(52.1)	81	63	0.30	(7.6)
2.04	(51.8)	88	70	0.29	(7.4)
2.03	(51.6)	92	73	0.28	(7.1)
2.02	(51.3)	96	76	0.27	(6.9)
2.01	(51.1)	100	79	0.26	(6.6)
2.00	(50.8)	104	82	0.25	(6.4)
1.99	(50.5)	108	85	0.24	(6.1)
1.98	(50.3)	112	88	0.23	(5.8)
1.97	(50.0)	116	91	0.22	(5.6)
1.96	(49.8)	120	94	0.21	(5.3)
1.95	(49.5)		97	0.20	(5.1)
1.94	(49.3)		100	0.19	(4.8)
1.93	(49.0)		103	0.18	(4.6)
1.92	(48.8)		106	0.17	(4.3)
1.91	(48.5)		109	0.16	(4.1)
1.90	(48.3)		112	0.15	(3.8)
1.89	(48.0)		115	0.14	(3.6)
1.88	(47.8)		118	0.13	(3.3)
1.87	(47.5)		121	0.12	(3.0)

1 Wear Chart: 942



Track Shoes <sup>(1)</sup>  
Triple Grouser

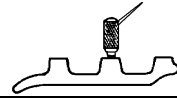
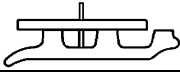

Depth Gauge			Ultrasonic	
Inches	(mm)	% Worn	Inches	(mm)
0.65	(16.5)	0	1.15	(29.2)
0.60	(15.0)	13	1.10	(27.9)
0.55	(14.0)	26	1.05	(26.7)
0.50	(12.5)	39	1.00	(25.4)
0.45	(11.5)	52	0.95	(24.1)
0.40	(10.0)	64	0.90	(22.9)
0.35	(9.0)	76	0.85	(21.6)
0.30	(7.5)	88	0.80	(20.3)
0.25	(6.5)	100	0.75	(19.1)
0.20	(5.0)	112	0.70	(17.8)
0.15	(4.0)	124	0.65	(16.5)

**PM565 — 6.75 in. (171.5 mm)**

**Track Shoes <sup>(1)</sup>  
Rubber Grouser**

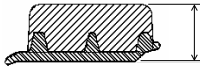

**Depth Gauge**

Inches	(mm)	% Worn
2.00	(50.5)	0
1.95	(49.5)	5
1.90	(48.0)	10
1.85	(47.0)	15
1.80	(45.5)	20
1.75	(44.5)	25
1.70	(43.0)	30
1.65	(42.0)	35
1.60	(40.5)	40
1.55	(39.5)	45
1.50	(38.0)	50
1.45	(36.5)	55
1.40	(35.5)	60
1.35	(34.0)	65
1.30	(33.0)	70
1.25	(31.5)	75
1.20	(30.5)	80
1.15	(29.0)	85
1.10	(28.0)	90
1.05	(26.5)	95
1.00	(25.5)	100
0.95	(24.0)	105
0.90	(23.0)	110
0.85	(21.5)	115
0.80	(20.0)	120

**NOTE**

Measure from the top of the grouser pad to the bottom of the mounting plate.

Idlers <sup>(1)</sup> <sup>(2)</sup> <sup>(3)</sup>

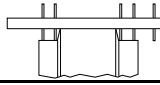

Depth Gauge

Inches	(mm)	% Worn
0.78	(20.0)	0
0.80	(20.5)	5
0.82	(21.0)	10
0.84	(21.5)	15
0.86	(22.0)	20
0.88	(22.5)	25
0.90	(23.0)	30
0.92	(23.5)	35
0.94	(24.0)	40
0.96	(24.5)	45
0.98	(25.0)	50
1.00	(25.5)	55
1.02	(26.0)	60
1.04	(26.5)	65
1.06	(27.0)	70
1.08	(27.5)	72
1.10	(28.0)	74
1.12	(28.5)	76
1.14	(29.0)	78
1.16	(29.5)	80
1.18	(30.0)	82
1.20	(30.5)	84
1.22	(31.0)	86
1.24	(31.5)	88
1.26	(32.0)	90
1.28	(32.5)	92
1.30	(33.0)	94
1.32	(33.5)	96
1.34	(34.0)	98
1.36	(34.5)	100
1.38	(35.0)	102
1.40	(35.5)	104
1.42	(36.0)	106
1.44	(36.5)	108
1.46	(37.0)	110
1.48	(37.5)	112
1.50	(38.0)	114
1.52	(38.5)	116
1.54	(39.0)	118
1.56	(39.5)	120

- 1 Flange width is 2.68 in. (68 mm)
- 2 New tread diameter is 18.70 in. (475 mm)
- 3 Wear Chart: 4349

# PM565 — 6.75 in. (171.5 mm)

## Track Rollers <sup>(1)</sup> <sup>(2)</sup>

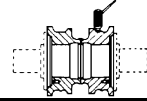

Caliper		% Worn	Depth Gauge		Ultrasonic	
Inches	(mm)		Inches	(mm)	Inches	(mm)
6.89	(175.0)	0	0.47	(12.0)	1.44	(36.6)
6.85	(174.0)	5	0.49	(12.5)	1.42	(36.1)
6.81	(173.0)	10	0.51	(13.0)	1.40	(35.6)
6.77	(172.0)	15	0.53	(13.5)	1.38	(35.1)
6.73	(171.0)	20	0.55	(14.0)	1.36	(34.5)
6.69	(170.0)	25	0.57	(14.5)	1.34	(34.0)
6.65	(169.0)	30	0.59	(15.0)	1.32	(33.5)
6.61	(168.0)	35	0.61	(15.5)	1.30	(33.0)
6.57	(167.0)	40	0.63	(16.0)	1.28	(32.5)
6.53	(166.0)	45	0.65	(16.5)	1.26	(32.0)
6.49	(165.0)	50	0.67	(17.0)	1.24	(31.5)
6.45	(164.0)	55	0.69	(17.5)	1.22	(31.0)
6.41	(163.0)	60	0.71	(18.0)	1.20	(30.5)
6.37	(162.0)	64	0.73	(18.5)	1.18	(30.0)
6.33	(161.0)	67	0.75	(19.0)	1.16	(29.5)
6.29	(160.0)	70	0.77	(19.5)	1.14	(29.0)
6.25	(159.0)	73	0.79	(20.0)	1.12	(28.4)
6.21	(157.5)	76	0.81	(20.5)	1.10	(27.9)
6.17	(156.5)	79	0.83	(21.0)	1.08	(27.4)
6.13	(155.5)	82	0.85	(21.5)	1.06	(26.9)
6.09	(154.5)	85	0.87	(22.0)	1.04	(26.4)
6.05	(153.5)	88	0.89	(22.5)	1.02	(25.9)
6.01	(152.5)	91	0.91	(23.0)	1.00	(25.4)
5.97	(151.5)	94	0.93	(23.5)	0.98	(24.9)
5.93	(150.5)	97	0.95	(24.0)	0.96	(24.4)
5.89	(149.5)	100	0.97	(24.5)	0.94	(23.9)
5.85	(148.5)	103	0.99	(25.0)	0.92	(23.4)
5.81	(147.5)	106	1.01	(25.5)	0.90	(22.9)
5.77	(146.5)	109	1.03	(26.0)	0.88	(22.4)
5.73	(145.5)	112	1.05	(26.5)	0.86	(21.8)
5.69	(144.5)	115	1.07	(27.0)	0.84	(21.3)
5.65	(143.5)	118	1.09	(27.5)	0.82	(20.8)
5.61	(142.5)	121	1.11	(28.0)	0.80	(20.3)

1 Flange diameter is 7.83 in. (199 mm)

2 Wear Chart: 5244



# Drive Belts

## Challenger Drive Belt Standard



Depth Gauge		
Inches	(mm)	% Worn
2.50	(63.5)	0
2.40	(61.5)	5
2.30	(58.5)	10
2.20	(56.0)	15
2.10	(53.5)	20
2.00	(51.0)	25
1.90	(48.5)	30
1.80	(45.5)	35
1.70	(43.0)	40
1.60	(40.5)	45
1.50	(38.0)	50
1.40	(35.5)	55
1.30	(33.0)	60
1.20	(30.5)	65
1.10	(28.0)	70
1.00	(25.5)	75
0.90	(23.0)	80
0.80	(20.5)	85
0.70	(18.0)	90
0.60	(15.0)	95
0.50	(12.5)	100
0.40	(10.0)	105
0.30	(7.5)	110
0.20	(5.0)	115
0.10	(2.5)	120

**Challenger Drive Belt  
Special Application**



**Depth Gauge**

<b>Inches</b>	<b>(mm)</b>	<b>% Worn</b>
1.50	(38.0)	0
1.40	(35.5)	9
1.30	(33.0)	18
1.20	(30.5)	27
1.10	(28.0)	36
1.00	(25.5)	44
0.90	(23.0)	52
0.80	(20.5)	60
0.70	(18.0)	68
0.60	(15.0)	76
0.50	(12.5)	84
0.40	(10.0)	92
0.30	(7.5)	100
0.20	(5.0)	108
0.10	(2.5)	116
0.00	(0.0)	124

# Drive Belts

## Paver Drive Belt



Depth Gauge

Inches	(mm)	% Worn
1.40	(35.5)	0
1.35	(33.0)	5
1.30	(31.0)	10
1.25	(30.5)	15
1.20	(29.5)	20
1.15	(28.0)	25
1.10	(26.0)	30
1.05	(25.5)	35
1.00	(25.5)	40
0.95	(24.0)	45
0.90	(22.5)	50
0.85	(21.5)	55
0.80	(20.0)	60
0.75	(19.0)	64
0.70	(17.5)	68
0.65	(16.5)	72
0.60	(15.0)	76
0.55	(14.0)	80
0.50	(12.5)	84
0.45	(11.5)	88
0.40	(10.0)	92
0.35	(9.0)	96
0.30	(7.5)	100
0.25	(6.0)	104
0.20	(5.0)	108
0.15	(3.5)	112
0.10	(2.5)	116
0.05	(1.0)	120





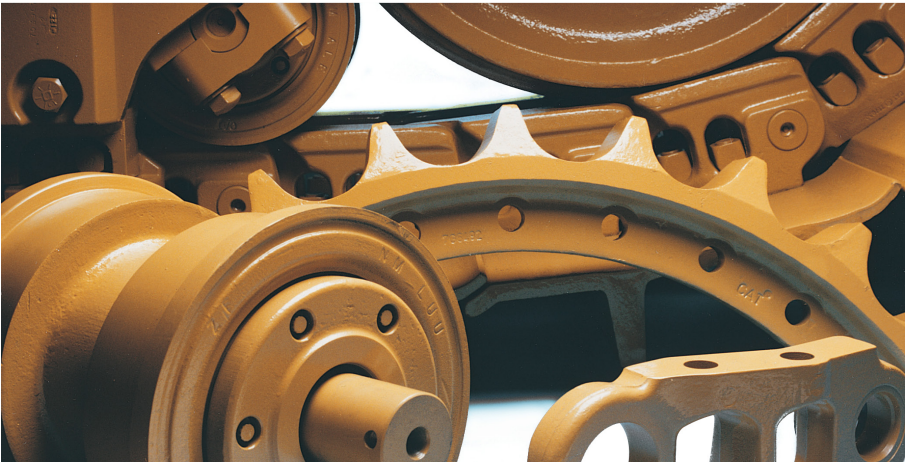

**BUILT FOR IT.™**

PEKP9400-08  
© 2015 Caterpillar. All Rights Reserved.  
CAT, CATERPILLAR, BUILT FOR IT, their respective logos, "Caterpillar Yellow,"  
the "Power Edge" trade dress as well as corporate and product identity used herein,  
are trademarks of Caterpillar and may not be used without permission.

