



INTRODUCTION

FORD 5R55S

FORD 5R55W

*Updated
March, 2004*

The Ford 5R55S and 5R55W transmissions are both very similar in design to the Ford 5R55N transmission and use electronic shift controls. The 5R55S/W are both "Synchronous" units, as they do not use the intermediate clutch and intermediate sprag that the 5R55N incorporates. The Ford 5R55S and 5R55W transmissions were introduced in 2002, found in the Ford Explorer and Mercury Mountaineer vehicles, and are available in both 2WD and 4WD configurations. For model year 2003 they are also in the Lincoln LS, Lincoln Aviator and Ford Thunderbird. They are designed for operation in longitudinal powertrains for rear wheel drive vehicles.

5R55S
Gear Ratios
1st Gear = 3.22
2nd Gear = 2.29
3rd Gear = 1.54
4th Gear = 1.00
5th Gear = 0.71
Reverse = 3.07

5R55W
Gear Ratios
1st Gear = 3.22
2nd Gear = 2.41
3rd Gear = 1.54
4th Gear = 1.00
5th Gear = 0.75
Reverse = 3.07

*We wish to thank Ford Motor Company
for the information and illustrations
that have made this booklet possible.*

No part of any ATSG publication may be reproduced, stored in any retrieval system or transmitted in any form or by any means, including but not limited to electronic, mechanical, photocopying, recording or otherwise, without **written** permission of Automatic Transmission Service Group. This includes all text illustrations, tables and charts.

*The information and part numbers contained in this booklet have
been carefully compiled from industry sources known for their
reliability, but ATSG does not guarantee its accuracy.*

DALE ENGLAND
FIELD SERVICE CONSULTANT

WAYNE COLONNA
TECHNICAL SUPERVISOR

PETER LUBAN
TECHNICAL CONSULTANT

JON GLATSTEIN
TECHNICAL CONSULTANT

JERRY GOTT
TECHNICAL CONSULTANT

GERALD CAMPBELL
TECHNICAL CONSULTANT

Copyright © ATSG 2004

JIM DIAL
TECHNICAL CONSULTANT

ED KRUSE
TECHNICAL CONSULTANT

GREGORY LIPNICK
TECHNICAL CONSULTANT

DAVID CHALKER
TECHNICAL CONSULTANT

STANTON ANDERSON
TECHNICAL CONSULTANT

ROLAND ALVAREZ
TECHNICAL CONSULTANT

MIKE SOUZA
TECHNICAL CONSULTANT

AUTOMATIC TRANSMISSION SERVICE GROUP
9200 S. DADELAND BLVD. SUITE 720
MIAMI, FLORIDA 33156
(305) 670-4161



FORD MOTOR CO. 5R55W/S INDEX

<i>5R55W/S TRANSMISSION IDENTIFICATION</i>	3
<i>COMPONENT APPLICATION CHART</i>	4
<i>SOLENOID APPLICATION AND RESISTANCE CHARTS</i>	5
<i>SOLENOID BODY PIN IDENTIFICATION</i>	6
<i>GENERAL DESCRIPTION AND OPERATION</i>	7
<i>MANUAL SHIFT SELECTOR OPERATION</i>	9
<i>BATTERY JUNCTION BOX FUSE AND RELAY LOCATIONS</i>	10
<i>CENTRAL JUNCTION BOX FUSE LOCATIONS</i>	10
<i>DIGITAL TRANSMISSION RANGE SENSOR</i>	11
<i>VARIOUS CONNECTOR AND PIN IDENTIFICATION</i>	12
<i>WIRING SCHEMATIC</i>	13
<i>PCM LOCATION</i>	15
<i>TRANSMISSION COMPONENT RESISTANCE CHART THROUGH PCM CONNECTOR</i>	16
<i>DIAGNOSTIC TROUBLE CODE CHART AND DESCRIPTION</i>	18
<i>LINE PRESSURE TESTS</i>	21
<i>CHECKING TRANSMISSION FLUID LEVEL</i>	22
<i>TRANSMISSION DISASSEMBLY</i>	24
<i>COMPONENT REBUILD SECTION</i>	
<i>OIL PUMP ASSEMBLY</i>	39
<i>COAST CLUTCH HOUSING</i>	43
<i>OVERDRIVE CARRIER AND OVERDRIVE SPRAG ASSEMBLY</i>	47
<i>DIRECT CLUTCH HOUSING</i>	49
<i>FORWARD CLUTCH HOUSING</i>	52
<i>CENTER SUPPORT ASSEMBLY</i>	57
<i>LOW SPRAG AND REVERSE DRUM ASSEMBLY</i>	58
<i>REAR RING GEAR AND HUB ASSEMBLY</i>	58
<i>FRONT AND REAR PLANETARY CARRIER ASSEMBLY</i>	60
<i>SUN GEAR AND SHELL ASSEMBLY</i>	61
<i>FRONT RING GEAR AND HUB ASSEMBLY</i>	61
<i>VALVE BODY ASSEMBLY</i>	65
<i>CHECKBALL LOCATIONS</i>	66
<i>REVERSE SERVO ASSEMBLY</i>	68
<i>SOLENOID BODY DIFFERENCES</i>	72
<i>SOLENOID BODY ASSEMBLY</i>	73
<i>4WD ADAPTER HOUSING AND PARKING PAWL ASSEMBLY</i>	74
<i>TRANSMISSION CASE ASSEMBLY</i>	76
<i>FINAL TRANSMISSION ASSEMBLY</i>	79
<i>REAR END CLEARANCE PROCEDURES</i>	84
<i>FRONT END CLEARANCE PROCEDURES</i>	93
<i>2WD EXTENSION HOUSING ASSEMBLY SECTION</i>	100
<i>BOLT SIZE AND LENGTH CHART</i>	105
<i>SPECIAL SERVICE TOOLS</i>	106
<i>TORQUE SPECIFICATIONS</i>	108
<i>5R55N VERSUS 5R55W/S DIFFERENCES</i>	108

AUTOMATIC TRANSMISSION SERVICE GROUP
9200 S. DADELAND BLVD. SUITE 720
MIAMI, FLORIDA 33156
(305) 670-4161

Copyright © ATSG 2004

FORD 5R55W/S

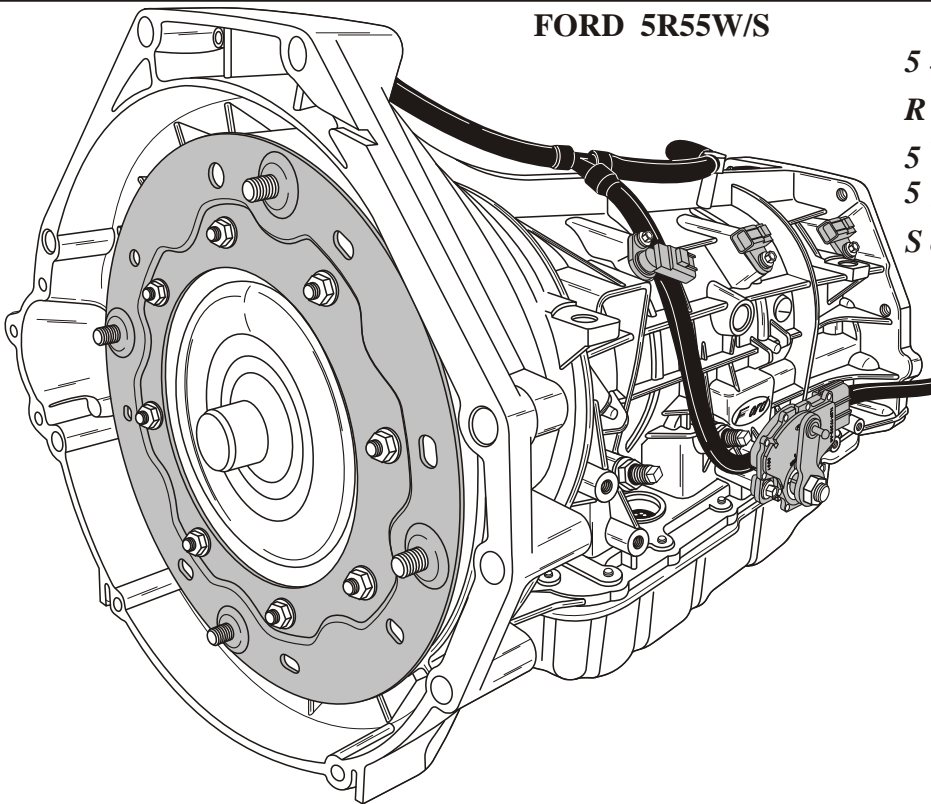

5 = 5 Forward Speeds
R = Rear Wheel Drive
5 } = Relative Torque Capacity
S or W = Synchronous

I.D. TAG INFORMATION FOUND ON RIGHT REAR SIDE OF TRANSMISSION

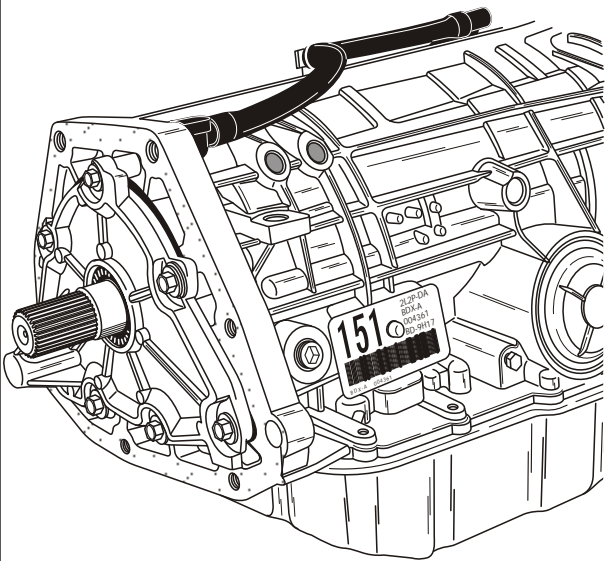

151

2L2P-DA ← 1

BDX-A ← 2

004361 ← 3

BD-2C17 ← 4

RJL-B 004361

1. Part Number, Basic = 7000 (Example 2L2Z-7000-DA)
2. Transmission Model Code
3. Serial Number
4. Build Date (YMDD) ←

	Year	Month	Day
BD-	9	C	17
Build Date	9=1999	A=Jan	
	0=2000	B=Feb	
	1=2001	C=Mar	
	2=2002	D=Apr	
	3=2003	E=May	
		F=Jun	
		G=Jul	
		H=Aug	
		J=Sep	
		K=Oct	
		L=Nov	
		M=Dec	

Figure 1

FORD 5R55W/S COMPONENT APPLICATION CHART

RANGE	FWD CLUT	DIR CLUT	COAST CLUT	O/D BAND	INT BAND	L/R BAND	O/D SPRAG	LOW SPRAG	TCS Switch	5R55W RATIO	5R55S RATIO
Park											
Reverse		ON				ON	HOLD			3.07	3.07
Neutral											
"D"-1st Gear	ON						HOLD	HOLD	OFF	3.22	3.22
"D"-2nd Gear	ON			ON				HOLD	OFF	2.41	2.29
"D"-3rd Gear	ON				ON		HOLD		OFF	1.54	1.54
"D"-4th Gear	ON	ON					HOLD		OFF	1.00	1.00
"D"-5th Gear	ON	ON		ON					OFF	0.75	0.71
"D"-1st Gear	ON		ON				HOLD	HOLD	ON	3.22	3.22
"D"-2nd Gear	ON			ON				HOLD	ON	2.41	2.29
"D"-3rd Gear	ON		ON		ON		HOLD		ON	1.54	1.54
"D"-4th Gear	ON	ON	ON				HOLD		ON	1.00	1.00
"3"-3rd Hold *	ON		ON		ON		HOLD			1.54	1.54
"2"-2nd Hold **	ON			ON		ON		HOLD		2.41	2.29
"1"-1st Hold ***	ON		ON			ON	HOLD	HOLD		3.22	3.22

* Manual "3" is 3rd gear starts and hold.

** Manual "2" is 2nd gear starts and hold.

*** Manual "1" provides 1st gear operation only.

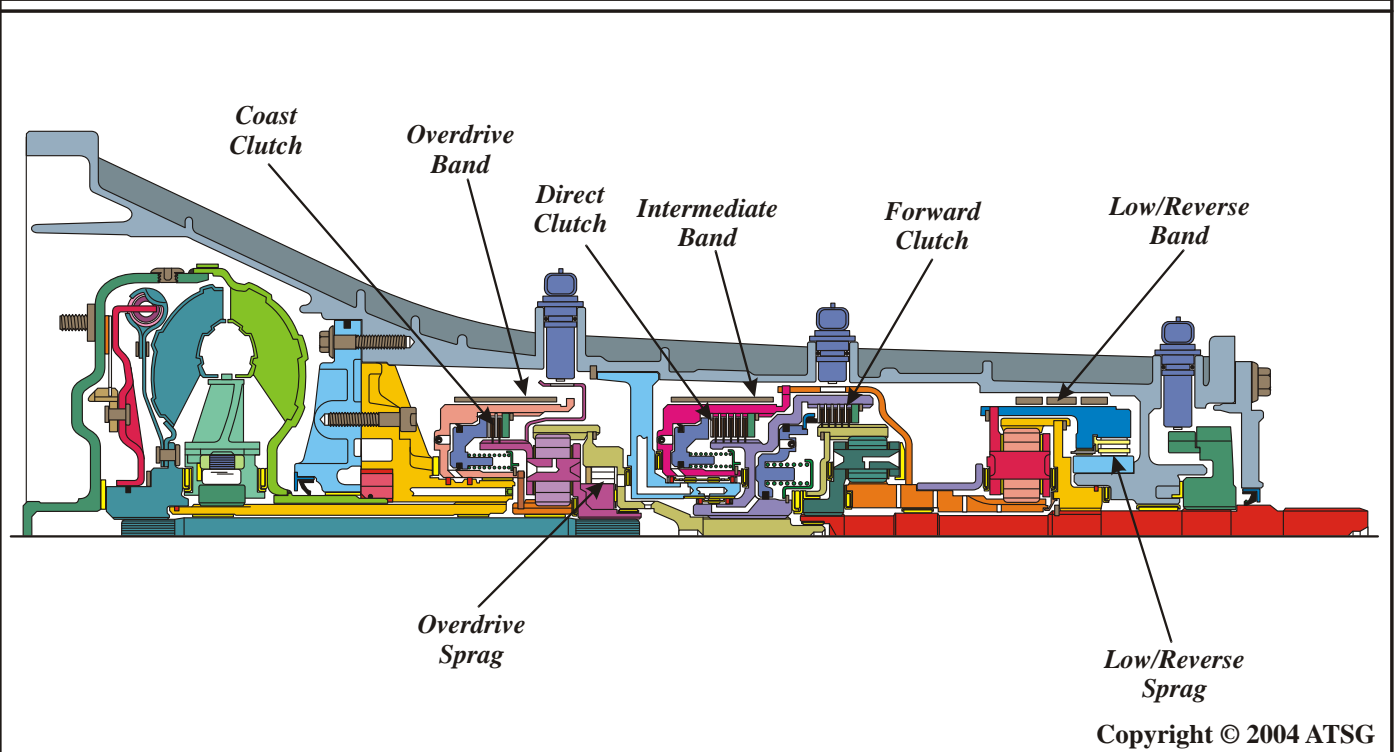

Copyright © 2004 ATSG

Figure 2



Technical Service Information

FORD 5R55W/S SOLENOID APPLY CHART								
Range And Gear Commanded	Shift Sol. "A"	Shift Sol. "B"	Shift Sol. "C"	Shift Sol. "D"	Pres Cont Sol. "A"	Pres Cont Sol. "B"	Pres Cont Sol. "C"	TCC Solenoid
Park/Neutral	ON			ON	"L"	"V"	"L"	
Reverse	ON			ON	"L"	"H"	"H"	
"D" - 1st Gear	ON			ON	"V"	"L"	"L"	
"D" - 2nd Gear	ON		ON	ON	"L"	"V"	"L"	**
"D" - 3rd Gear	ON	ON		ON	"V"	"L"	"L"	**
"D" - 4th Gear				ON	"V"	"L"	"H"	**
"D" - 5th Gear			ON	ON	"V"	"V"	"H"	**
"D" - 1st Gear	ON			ON	"V"	"L"	"L"	
"D" - 2nd Gear	ON		ON	ON	"L"	"V"	"L"	**
"D" - 3rd Gear	ON	ON		ON	"V"	"L"	"L"	**
"D" - 4th Gear					"V"	"V"	"H"	**
"3" - 3rd Gear (Hold)	ON	ON			"V"	"V"	"L"	
"2" - 2nd Gear (Hold)	ON		ON		"V"	"V"	"L"	
"1" - 1st Gear (Hold)	ON				"V"	"V"	"L"	
<p>"L" = Lower Line Pressure "V" = Variable Line Pressure "H" = Higher Line Pressure ** = TCC may be On, and is dependent on vehicle speed and throttle position</p>								
CASE CONNECTOR PIN IDENTIFICATION AND RESISTANCE CHARTS								
Solenoid Resistance Chart			TOT Sensor Resistance Chart					
Component	Connector Terminals	Resistance In Ohms	0°F-31°F = 284k - 100k Ohms					
Shift Solenoid "A"	3 And 16	16-45	32°F-68°F = 100k - 37k Ohms					
Shift Solenoid "B"	3 And 15	16-45	69°F-104°F = 37k - 16k Ohms					
Shift Solenoid "C"	3 And 6	16-45	105°F-158°F = 16k - 5k Ohms					
Shift Solenoid "D"	3 And 5	16-45	159°F-194°F = 5k - 2.7k Ohms					
Pressure Control Solenoid "A"	3 And 11	3.3-7.5	195°F-230°F = 2.7k - 1.5k Ohms					
Pressure Control Solenoid "B"	3 And 1	3.3-7.5	231°F-266°F = 1.5k - 0.8k Ohms					
Pressure Control Solenoid "C"	3 And 4	3.3-7.5	267°F-302°F = 0.8k - 0.54k Ohms					
TCC Solenoid	3 And 14	9-16						
TOT Sensor	2 And 12	See Chart						
<p>Refer To Figure 4 For Case Connector Pin Identification</p>								
<p>Copyright © 2004 ATSG</p>								

Figure 3

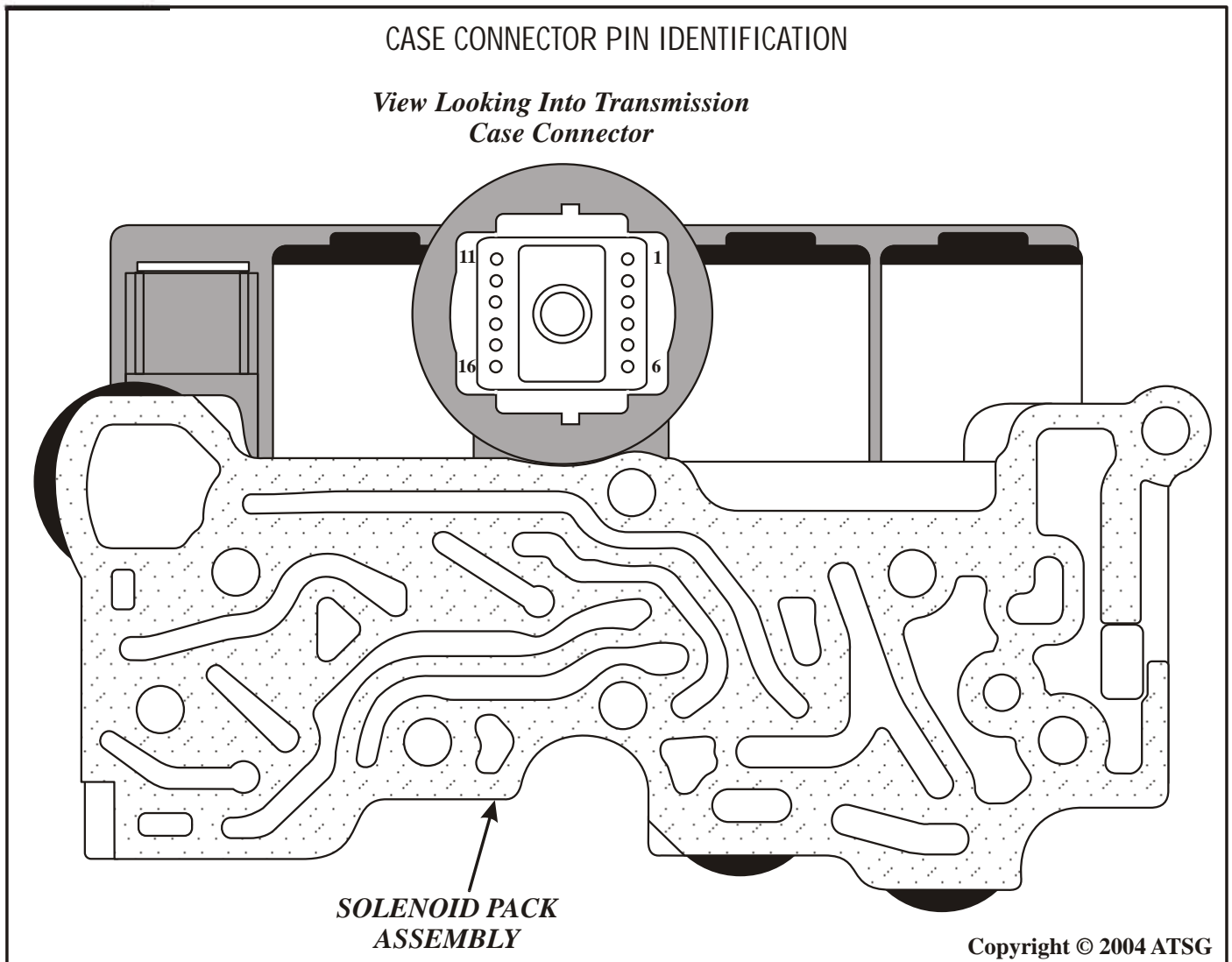

Figure 4

"FAIL-SAFE" DESCRIPTION AND OPERATION

If the Powertrain Control Module (PCM) detects an input sensor or signal fault, it may use Failure Management Effects Mode (FMEM) strategy and provide a substitute signal or value.

If the transmission totally loses electronic control, it will operate in a Fail-Safe mode with all of the following features:

- Maximum line pressure in all transmission shifter positions.
- Fully functional "P", "R" and "N" transmission shifter positions.
- Operation in 4th gear only with coast braking when the selector is in the "D", "3", "2", or "1" positions.
- Torque Converter Clutch (TCC) will be released in all positions.



Technical Service Information

GENERAL DESCRIPTION AND OPERATION

The 5R55W/S is a fully automatic rear wheel drive transmission. It provides Park, Reverse, Neutral, and five forward speeds with 5th gear being overdrive

Internally it looks *similar* to the previous 5R55E transmission, but there are very few minor components that are actually the same, so be very cautious during the rebuild process. The major components used in this unit are as follows:

- **3 Multi-Plate Clutch Packs**
 - Coast Clutch*
 - Direct Clutch (Single Sided)*
 - Forward Clutch*

- **2 One-Way Clutches**
 - Overdrive Sprag Clutch*
 - Low Sprag Clutch*

- **3 Brake Bands**
 - Overdrive Band*
 - Intermediate Band*
 - Low/Reverse Band*

- **3 Compound Planetary Gear Sets**
 - Overdrive Planetary Set*
 - Forward Planetary Set*
 - Rear Planetary Set*

The shift pattern is controlled electronically with four (On-Off) solenoids that receive a ground signal from the PCM (Powertrain Control Module). The PCM will vary shift points, as it is constantly interpreting numerous electronic signals from various operational sensors located on the vehicle and inside the transmission.

Line pressure and shift feel are also controlled electronically with three Pressure Control solenoids, referred to as PCA, PCB, and PCC. The PCM varies the current to the pressure control solenoids and Ford refers to them as Variable Force Solenoids.

The PCM also controls application of the converter clutch and apply feel electronically, with a TCC solenoid, which is also Variable Force style.

All solenoids are incorporated in the "Solenoid Body", located on the valve body, and are not serviced separately. You must purchase the entire solenoid body assembly, if necessary.

ELECTRONIC COMPONENTS

The PCM also receives input signals from various sensors and switches, located *internally and externally*, that affect proper transmission operation. The following will provide a brief description of each of the sensors and actuators used for transmission operations.

AIR CONDITIONING CLUTCH

This switch is located on the suction accum/drier and when the A/C is engaged, operating pressures are adjusted to compensate for the additional engine load.

BRAKE PEDAL POSITION (BPP) SWITCH

This switch is located on the brake pedal and tells the PCM when the brakes are applied. The TCC is disengaged when the brakes are applied. The BPP switch closes when the brakes are applied and open when they are released.

ENGINE COOLANT TEMPERATURE (ECT) SENSOR

This sensor detects temperature of engine coolant and supplies the information to the PCM. The PCM uses this information to control Torque Converter Clutch (TCC) operation.

ELECTRONIC IGNITION (EI) SYSTEM

The ignition control module generates a Profile Ignition Pickup (PIP) signal (engine rpm) and sends it to the PCM. The PCM uses PIP signal in the transmission strategy for WOT shift control, TCC control and operating pressures.

INTAKE AIR TEMPERATURE (IAT) SENSOR

The Intake Air Temperature (IAT) sensor, located in the air cleaner outlet tube, is also used in the transmission strategy to determine control pressures.

MASS AIR FLOW (MAF) SENSOR

The Mass Air Flow (MAF) sensor, located in the air cleaner inlet tube, measures the amount of air flowing into the engine and sends this information (engine load) to the PCM. For transmission strategies the MAF is used to regulate electronic pressure control, shift timing and torque converter clutch scheduling.

Continued On Next Page

Copyright © 2004 ATSG



Technical Service Information

ELECTRONIC COMPONENTS (Cont'd)

TRANSMISSION CONTROL SWITCH (TCS)

The Transmission Control Switch (TCS), located within the manual shift selector assembly, as shown in Figure 5, is a momentary contact switch. When this switch is pressed, overdrive (5th gear) will be canceled. After the TCS has been pressed to request overdrive cancel, the PCM turns ON the Transmission Control Indicator Lamp (TCIL) to indicate that overdrive cancel mode is activated.

TRANSMISSION CONTROL INDICATOR LAMP (TCIL)

The Transmission Control Indicator Lamp (TCIL), is located on the manual shift lever, as shown in Figure 5, or in the instrument panel and illuminates when the TCS switch is pressed. When the TCIL is "ON", overdrive is OFF or canceled.

The PCM will also "Flash" the TCIL when it detects a fault in one of the solenoids or monitored sensors or switches.

THROTTLE POSITION SENSOR (TPS)

The Throttle Position Sensor is a potentiometer located on the throttle body and is used to detect throttle plate position and send this information to the PCM. The PCM uses this information for shift scheduling, pressure control and TCC control.

DIGITAL TRANSMISSION RANGE (TR) SENSOR

The Digital Transmission Range (TR) sensor is located on the outside of the transmission at the manual shift lever. The digital TR sensor completes the start circuit in Park and Neutral, and the back-up lamp circuit in Reverse. The digital TR sensor also opens or closes a set of four switches that are monitored by the PCM to determine the position of the manual lever (P, R, N, D, 3, 2, 1).

TURBINE SHAFT SPEED (TSS) SENSOR

The Turbine Shaft Speed (TSS) sensor is mounted externally on the transmission case, and triggered by the overdrive carrier. The PCM uses TSS to help determine appropriate operating pressures and TCC operation.

INTERMEDIATE SHAFT SPEED (ISS) SENSOR

The Intermediate Shaft Speed (ISS) sensor is mounted externally on the case, and triggered by the sun gear shell. The PCM uses ISS to aid in determining appropriate pressure requirements.

OUTPUT SHAFT SPEED (OSS) SENSOR

The Output Shaft Speed (OSS) sensor is mounted externally on the transmission case, and triggered by a speed rotor on the parking gear on the output shaft. The PCM uses OSS to determine appropriate shift speed scheduling, operating pressures and TCC operation.

PRESSURE CONTROL SOLENOIDS (PCA, PCB, PCC)

The Pressure Control solenoids PCA, PCB and PCC are located in the solenoid body assembly and are a variable-force style (VFS) solenoid. The VFS type solenoid is an electro-hydraulic actuator that combines a solenoid and a regulating valve. The PCM varies the current to all three pressure control solenoids.

The line pressure tap is used to verify output pressure from "PCA" or "PCB" by turning off either one, while verifying the output from the other solenoid. The second pressure tap is used to verify the output pressure from "PCC" solenoid.

SHIFT SOLENOIDS (SSA, SSB, SSC, SSD)

The four On-Off Shift Solenoids are three-way, normally open style solenoids, and also located in the solenoid body assembly. The four shift solenoids, (SSA, SSB, SSC, SSD), provide gear selection of 1st through 5th and reverse gears by directing control pressures to the appropriate element. Coast braking and manual gear selections are also controlled by the shift solenoids.

TORQUE CONVERTER CLUTCH (TCC) SOLENOID

The Torque Converter Clutch (TCC) solenoid is a pulse width modulating type of solenoid and is used to control the apply and release of the TCC. Like the others, it is located in the solenoid body assembly.

TRANSMISSION FLUID TEMPERATURE (TFT) SENSOR

The Transmission Fluid Temperature (TFT) sensor, located in the solenoid body, is a thermister type sensor that varies a reference signal to the PCM. The PCM uses this information to determine fluid temperature. The shift schedule is changed when fluid is cold. The PCM also inhibits TCC operation, and compensates pressure control solenoids when fluid is cold. The PCM uses TFT signal to help determine shift scheduling, TCC operation and pressure control requirements.

Copyright © 2004 ATSG

INSTRUMENT PANEL RANGE SELECTOR INDICATOR

Vehicles equipped with the 5R55W/S series transmissions have a Transmission Control Switch (TCS) and a Transmission Control Indicator Lamp (TCIL), as shown in Figure 5. The shift quadrant has the following positions P, R, D, 3, 2 and 1, as shown in Figure 5.

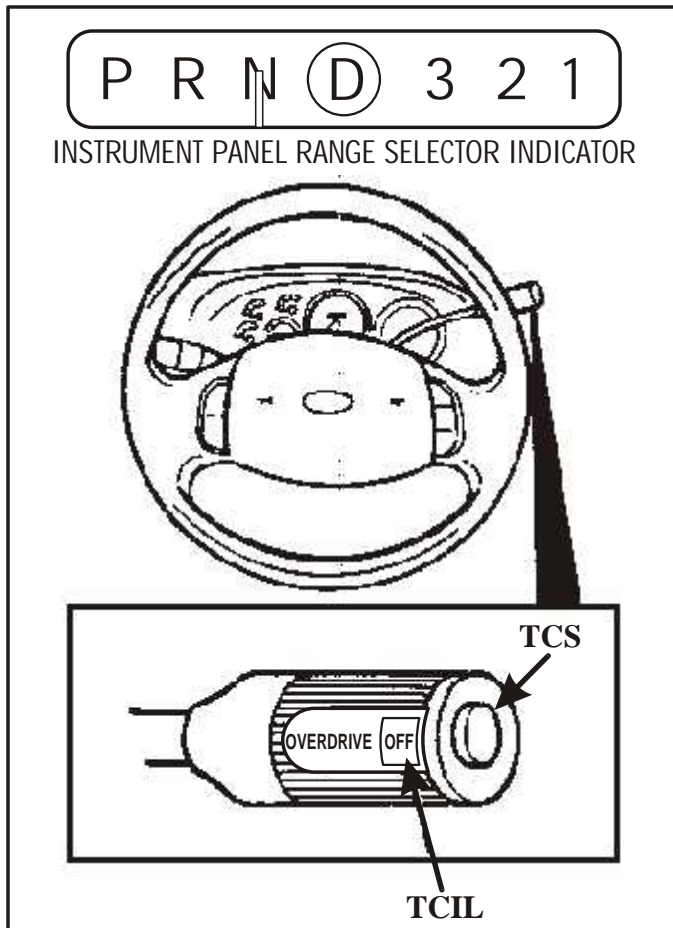

Figure 5

MANUAL SHIFT SELECTOR

"P" = Park

When in the Park position, there is no power flow through the transmission and the parking pawl locks the output shaft to the case. The engine may be started and the key may be removed.

"R" = Reverse

When in the Reverse position, the vehicle may be operated in a rearward direction at a reduced gear ratio, and the back-up lamps are illuminated.

"N" = Neutral

When in the Neutral position, there is no power flow through the transmission, the output shaft is not held and is free to turn. The engine may be started and the key can not be removed.

"D" = Overdrive (TCS "OFF")

When in the D position, with the TCS switch "OFF", there will be automatic upshifts 1st through 5th gear, automatic downshifts 5th through 1st gear, and apply and release of the TCC depending on vehicle speed, throttle position and engine coolant temperature. This is the normal position for most forward driving and provides the maximum fuel economy during normal operation. This unit also has engine braking in 5th gear.

"D" = With TCS "ON"

When in the D4 position, with the TCS switch "ON", there will be automatic upshifts 1st through 4th gear, automatic downshifts 4th through 1st gear, and apply and release of the TCC depending on vehicle speed, throttle position and engine coolant temperature. This position may be selected for towing, or driving in hilly terrain. This unit also has engine braking in 4th gear.

"3" = 3rd Gear

This position provides a pull-in shift to 3rd gear with coast braking. After an automatic downshift, a 3rd gear hold occurs with coast braking. In this position 3rd gear starts occur.

"2" = 2nd Gear

This position provides a pull-in shift to 2nd gear with coast braking. After an automatic downshift, a 2nd gear hold occurs with coast braking. In this position 2nd gear starts occur.

"1" = 1st Gear

This position provides 1st gear operation only, and used for descending steep grades. If this position is selected at normal road speeds, the transmission will downshift to the next lower gear, and continue downshifting at safe pre-calibrated road speeds until it reaches 1st gear.

CENTRAL JUNCTION BOX

<i>CENTRAL JUNCTION BOX (UNDERDASH)</i>	
<i>Transmission Related Fuses Only</i>	
<i>FUSE</i>	<i>APPLICATION</i>
<i>F27</i>	<i>Digital Range Sensor (Reverse Lamps) (7.5A)</i>
<i>F29</i>	<i>Digital Transmission Range Sensor (10A)</i>

Located Under Dash Panel, Driver Side

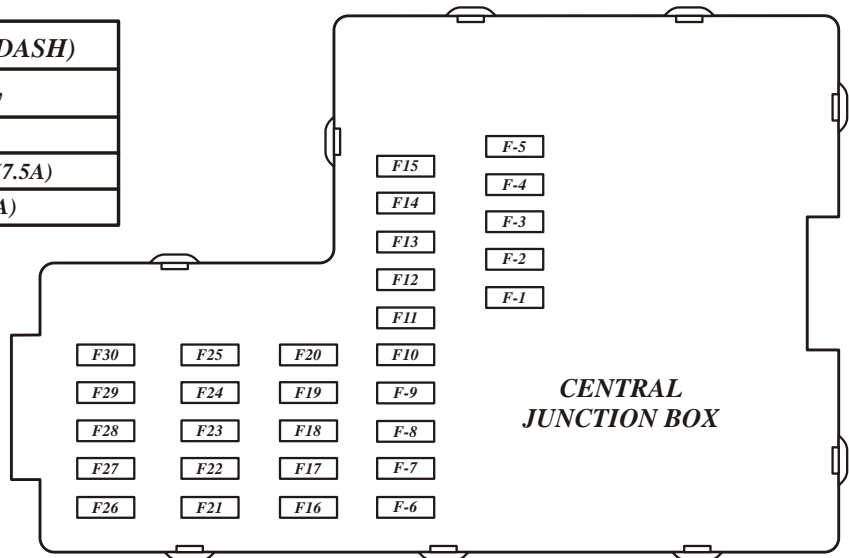

CENTRAL JUNCTION BOX

BATTERY JUNCTION BOX

Battery Junction Box

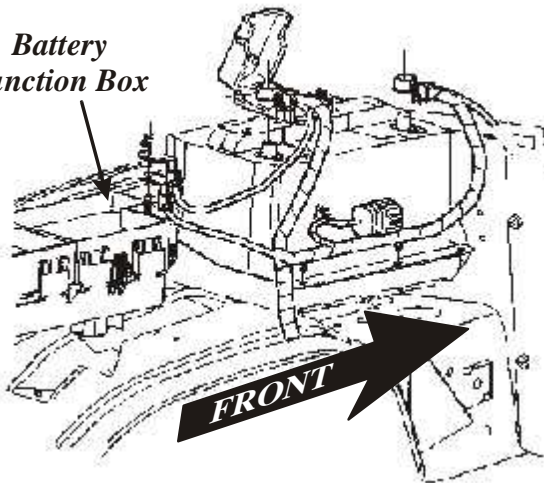

BATTERY JUNCTION BOX (UNDERHOOD)

Transmission Related Fuses Only

<i>FUSE</i>	<i>APPLICATION</i>
<i>F11</i>	<i>PCM Power Relay (40A)</i>
<i>F12</i>	<i>Starter/Ignition Relay (50A)</i>
<i>F15</i>	<i>Powertrain Control Module PCM (15A)</i>
<i>F17</i>	<i>4WD Control Module (20A)</i>
<i>F18</i>	<i>4WD Control Module (20A)</i>
<i>F37</i>	<i>A/C Relay, Trans Solenoid Body (Term 3) (15A)</i>
<i>F40</i>	<i>Powertrain Control Module, MAF, Cruise (15A)</i>
<i>F41</i>	<i>PCM Power Relay, PCM Power Diode (15A)</i>

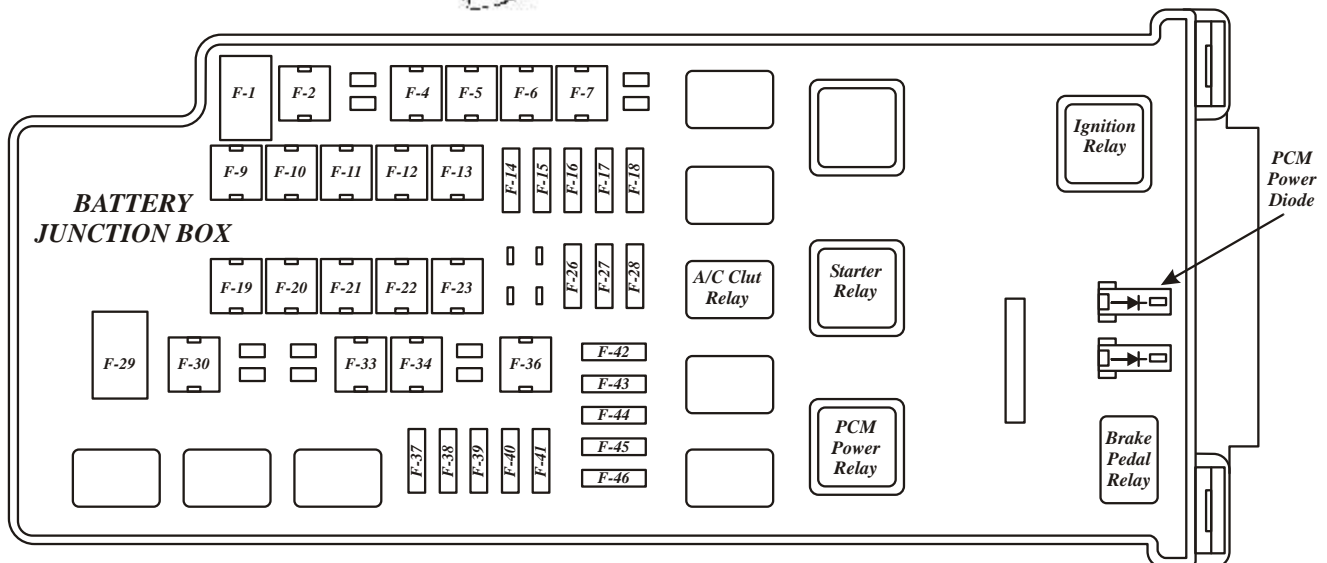

Copyright © 2004 ATSG

Figure 6

DIGITAL TRANSMISSION RANGE (DTR) SENSOR DIAGNOSIS

SELECTOR POSITION	PID:TR	PID:TR_D				PID:TR_V
		TR4	TR3A	TR2	TR1	TR3A (175B pin 9 to sig rtn)
PARK	P/N	0	0	0	0	0.0 Volts
REVERSE	REV	1	1	0	0	1.3 to 1.8 Volts
NEUTRAL	NTRL	0	1	1	0	1.3 to 1.8 Volts
OVERDRIVE	OD*	1	1	1	1	1.3 to 1.8 Volts
MANUAL 3	MAN 3	1	0	1	0	0.0 Volts
MANUAL 2	MAN 2	1	0	0	1	0.0 Volts
MANUAL 1	MAN 1	0	0	1	1	0.0 Volts

** Will read "Drive" if OD is canceled.*

1. TR_V is the voltage at PCM connector 175B, pin 9 (TR3A Circuit) to Signal Return.
2. "In-Between" reading may be caused by shift cable or DTR sensor misalignment or a DTR circuit failure of TR1, TR2, TR3A, TR4.
3. TR_D: 1 = Open DTR Switch
0 = Closed DTR Switch

4. Breakout Box readings are taken from PCM signal pins for TR1, TR2, TR3A, TR4 to Signal Return.
 Voltages for TR1, TR2, TR4: 0 = 0.0 Volts (Shorted to Ground)
 1 = 9.0 to 14.0 Volts (Open Circuit)
 Voltages for TR3A: 0 = 0.0 Volts (Circuit Shorted to Ground)
 1 = 1.3 to 5.0 Volts (Open Circuit)
 1.8 to 5.0 Volts is an invalid reading and is usually an open in wires or bad resistor in DTR sensor.

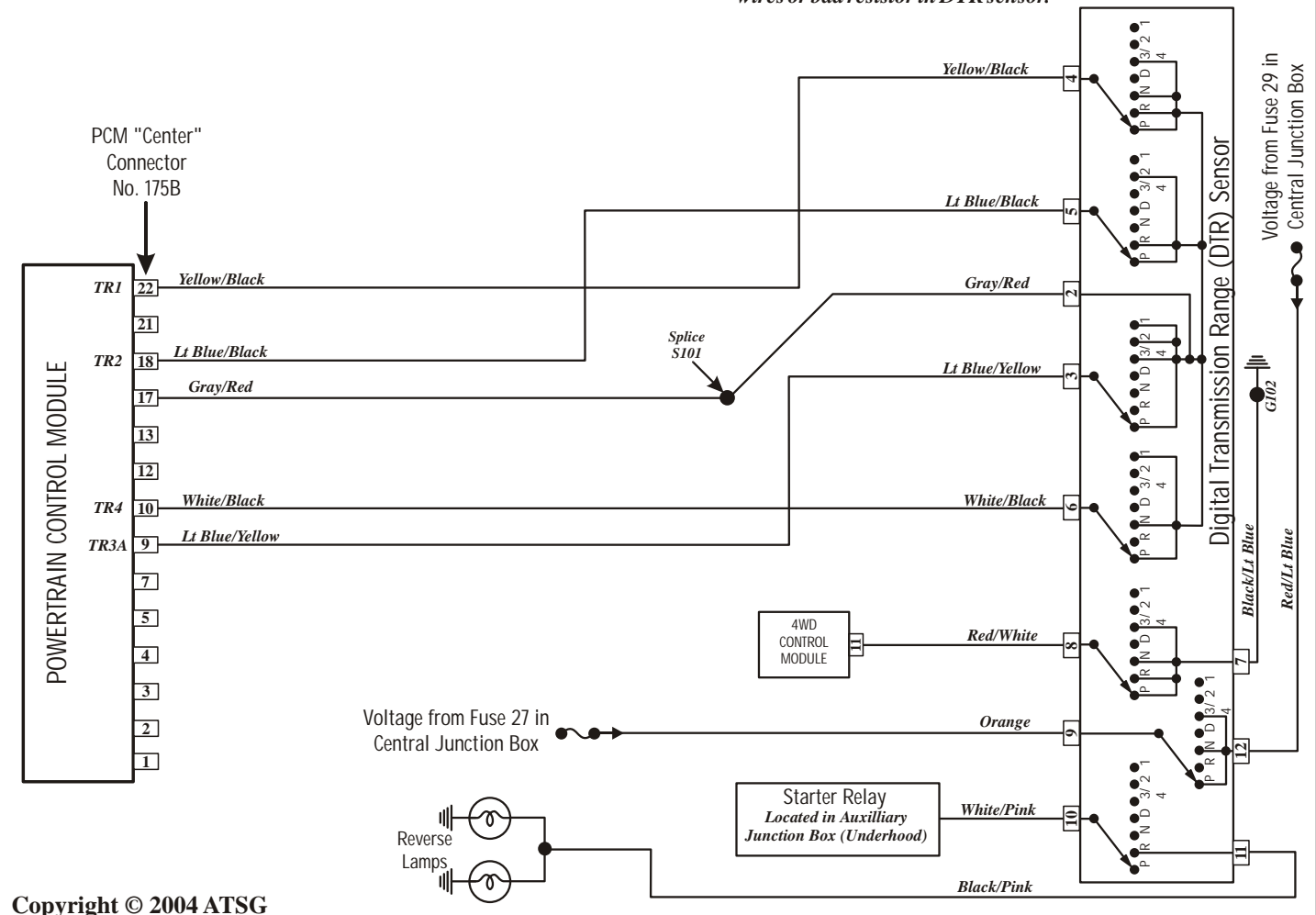

Copyright © 2004 ATSG

Figure 7

VARIOUS CONNECTOR AND PIN IDENTIFICATION

(All Connector Views Are Looking Into Connectors With Connector Removed)

PCM Connector
Number 175A

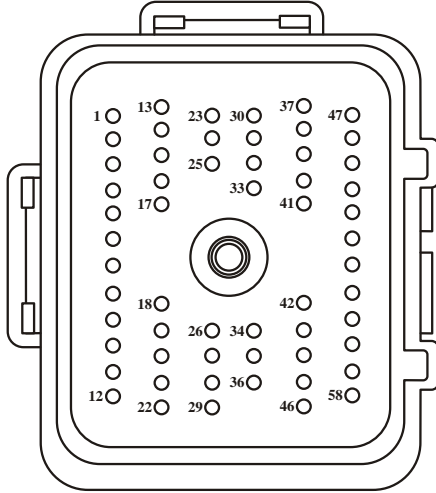

PCM Connector
Number 175B

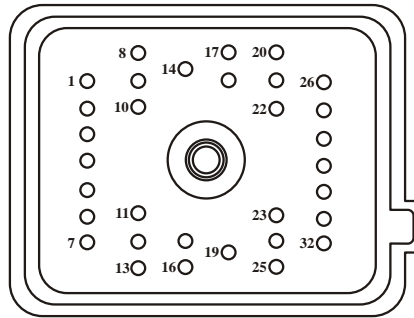

PCM Connector
Number 175C

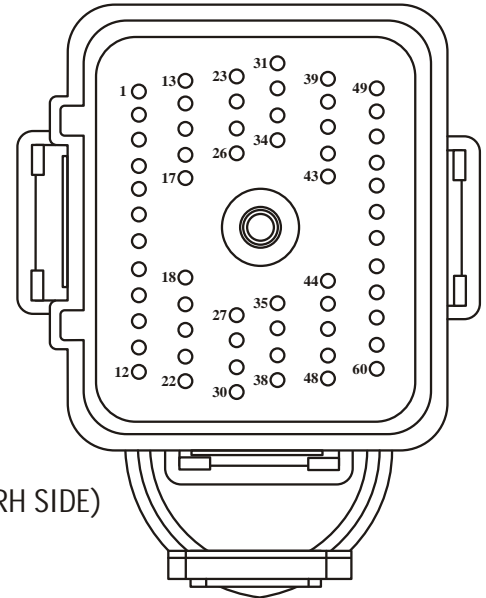

(PCM LOCATION, ENGINE COMPARTMENT - RH SIDE)

Data Link
Connector

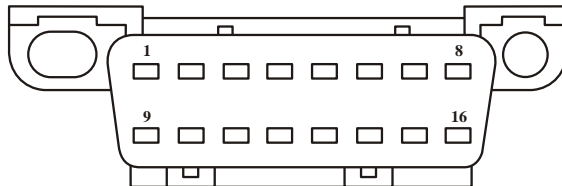

Solenoid Body
Connector

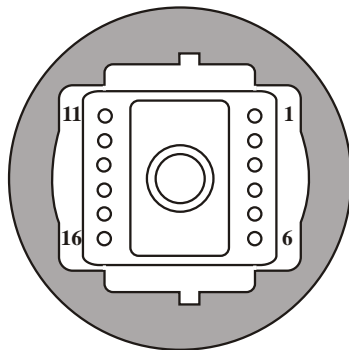

Digital Transmission
Range Sensor Connector

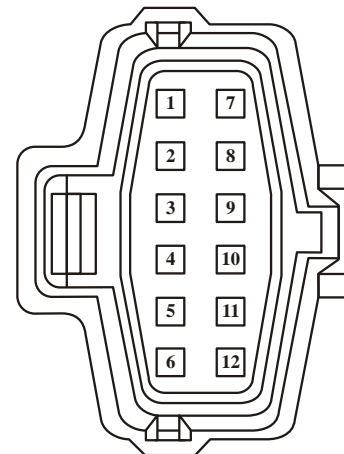

Figure 8

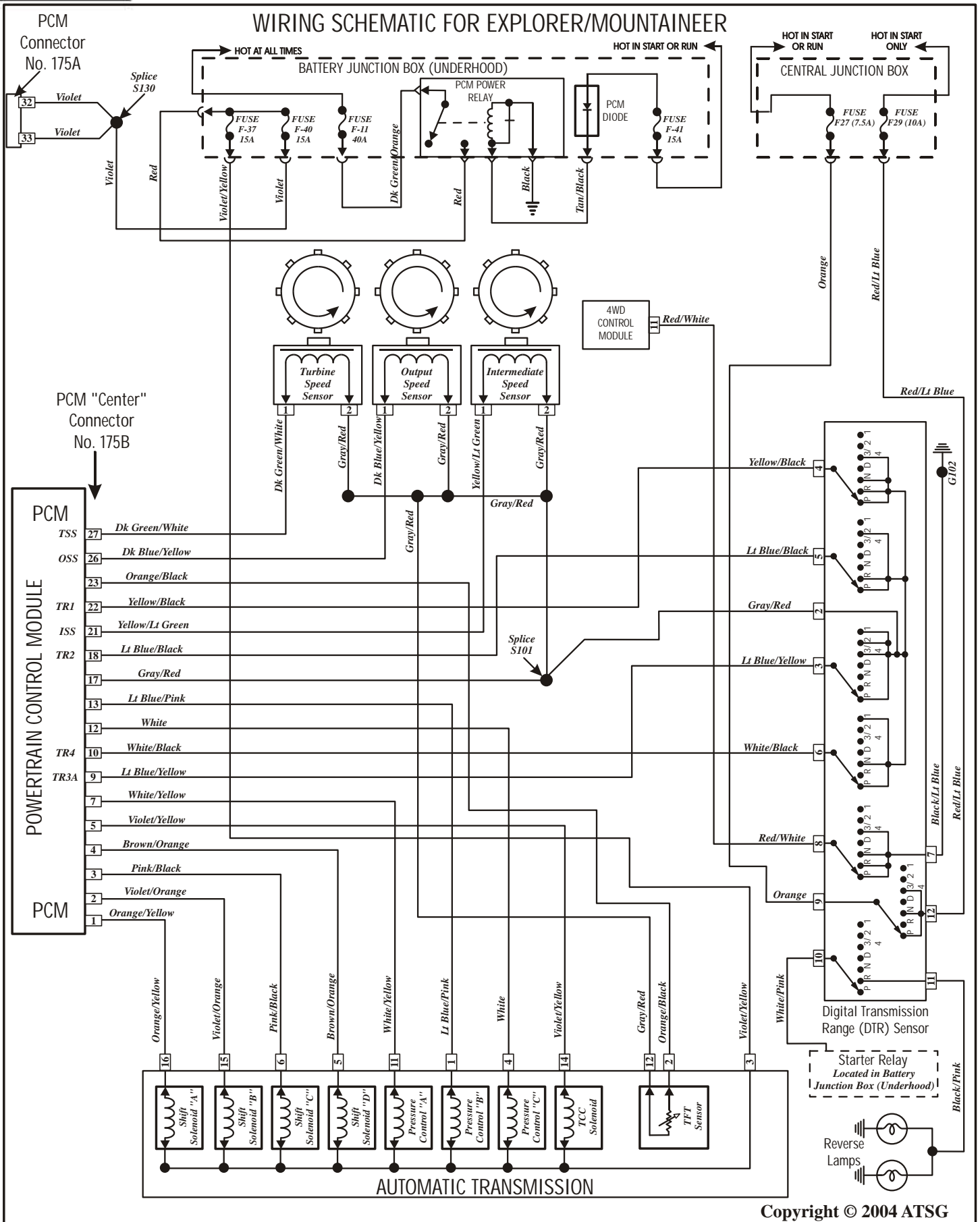
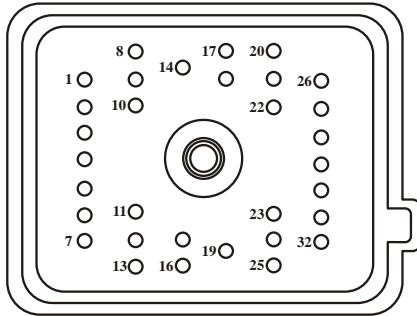
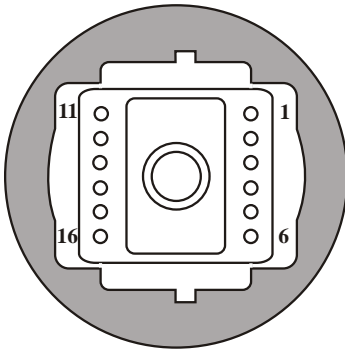

Figure 9

PCM Connector
Number 175B



Solenoid Body
Connector



Digital Transmission
Range Sensor Connector

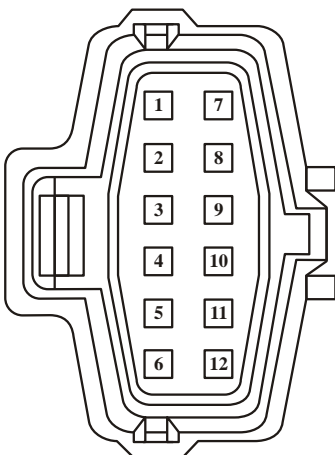

PCM CONNECTOR NUMBER 175B

PIN NO.	TRANSMISSION CIRCUIT FUNCTION ONLY
1	Shift Solenoid "A" (SSA) ground signal from PCM
2	Shift Solenoid "B" (SSB) ground signal from PCM
3	Shift Solenoid "C" (SSC) ground signal from PCM
4	Shift Solenoid "D" (SSD) ground signal from PCM
5	Torque Converter Clutch (TCC) ground signal from PCM
7	Pressure Control Solenoid "A" (PC A) ground signal from PCM
9	Digital Transmission Range (DTR) Sensor TR3A signal to PCM
10	Digital Transmission Range (DTR) Sensor TR4 signal to PCM
12	Pressure Control Solenoid "C" (PC C) ground signal from PCM
13	Pressure Control Solenoid "B" (PC B) ground signal from PCM
17	Sensor signal return (Ground)
18	Digital Transmission Range (DTR) Sensor TR2 signal to PCM
21	Intermediate Shaft Speed (ISS) Sensor signal to PCM
22	Digital Transmission Range (DTR) Sensor TR1 signal to PCM
23	Transmission Fluid Temperature (TFT) Sensor signal to PCM
26	Output Shaft Speed (OSS) Sensor signal to PCM
27	Turbine Shaft Speed (TSS) Sensor signal to PCM

SOLENOID BODY CONNECTOR

PIN NO.	CIRCUIT FUNCTION
1	Pressure Control Solenoid "B" (PC B) ground signal from PCM
2	Transmission Fluid Temperature (TFT) Sensor signal to PCM
3	Battery Voltage in from Fuse 37 in Battery Junction Box
4	Pressure Control Solenoid "C" (PC C) ground signal from PCM
5	Shift Solenoid "D" (SSD) ground signal from PCM
6	Shift Solenoid "C" (SSC) ground signal from PCM
11	Pressure Control Solenoid "A" (PC A) ground signal from PCM
12	Sensor signal return (Ground)
14	Torque Converter Clutch (TCC) ground signal from PCM
15	Shift Solenoid "B" (SSB) ground signal from PCM
16	Shift Solenoid "A" (SSA) ground signal from PCM

DIGITAL TRANS RANGE CONNECTOR

PIN NO.	CIRCUIT FUNCTION
2	Sensor signal return (Ground)
3	Digital Transmission Range (DTR) Sensor TR3A signal to PCM
4	Digital Transmission Range (DTR) Sensor TR1 signal to PCM
5	Digital Transmission Range (DTR) Sensor TR2 signal to PCM
6	Digital Transmission Range (DTR) Sensor TR4 signal to PCM
7	Ground wire to G102 ground
8	Selector Lever Signal to 4WD Control Module
9	Battery Voltage from Fuse F27 in Central Junction Box for reverse lamps
10	Battery Voltage to starter relay in Battery Junction Box, in start position only
11	Battery Voltage to reverse lamps
12	Battery Voltage from Fuse F29 in Central Junction Box for starter circuit

Figure 10

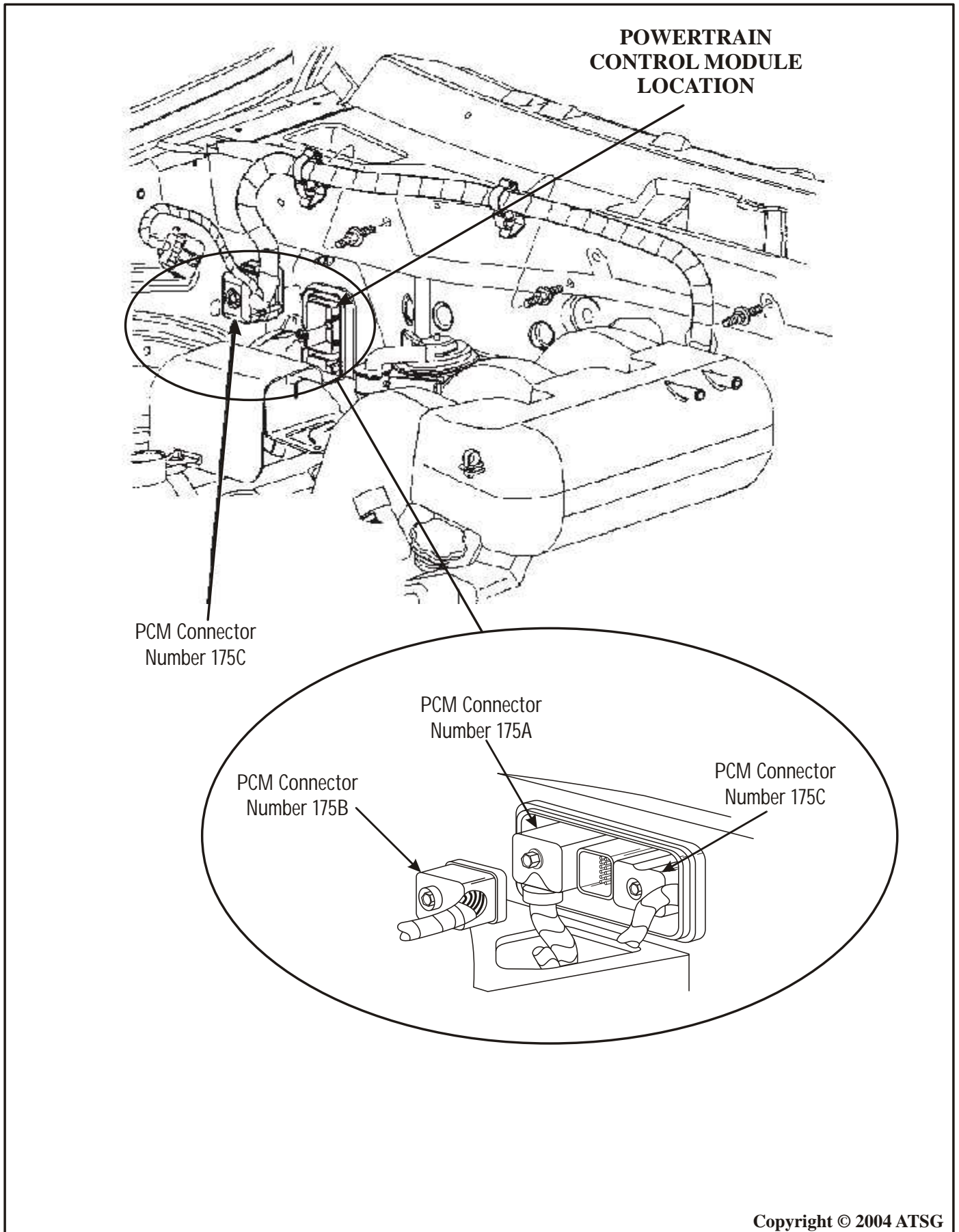
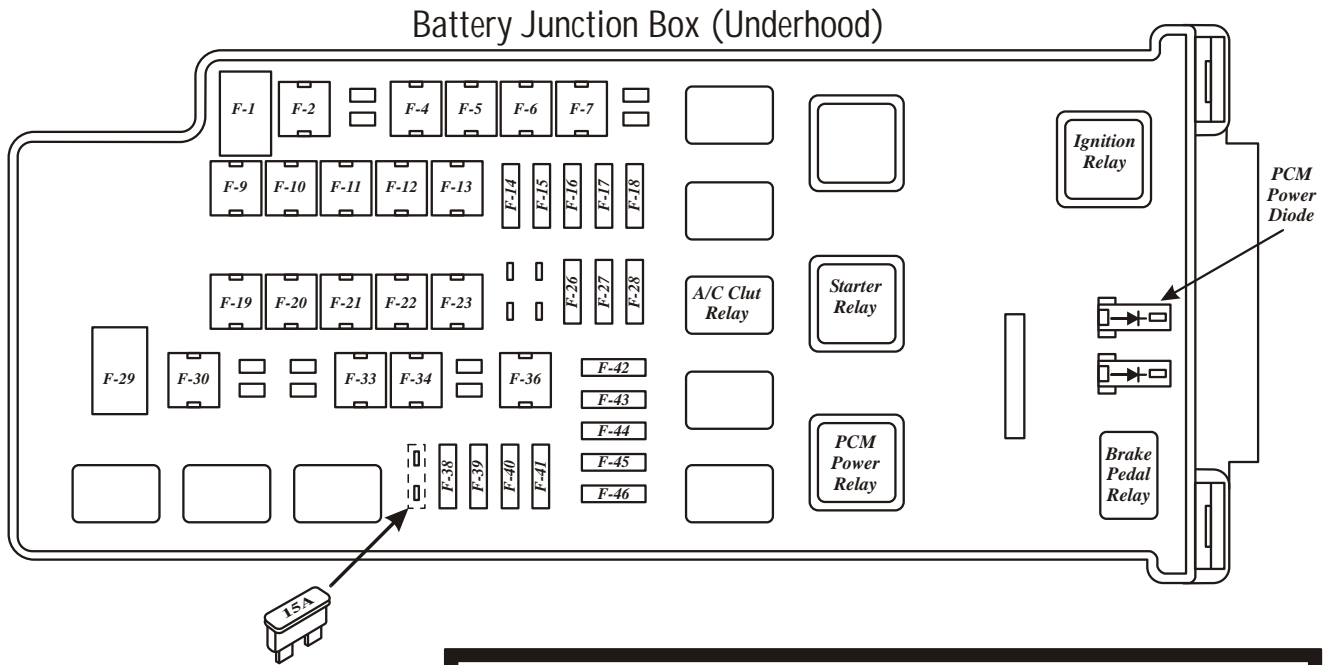

Figure 11

RESISTANCE CHART FOR TRANSMISSION COMPONENTS



Remove 15 Amp Fuse F-37

Transmission Component Resistance Checks Through PCM Connector 175B

1. Remove Fuse 37 from Battery Junction Box, as shown.
2. Remove PCM Connector 175B, as shown below.
3. Use resistance chart found in Figure 13 for pin numbers.

Remove PCM Connector (Center) Number 175B

PCM Connector Number 175B (Face View)

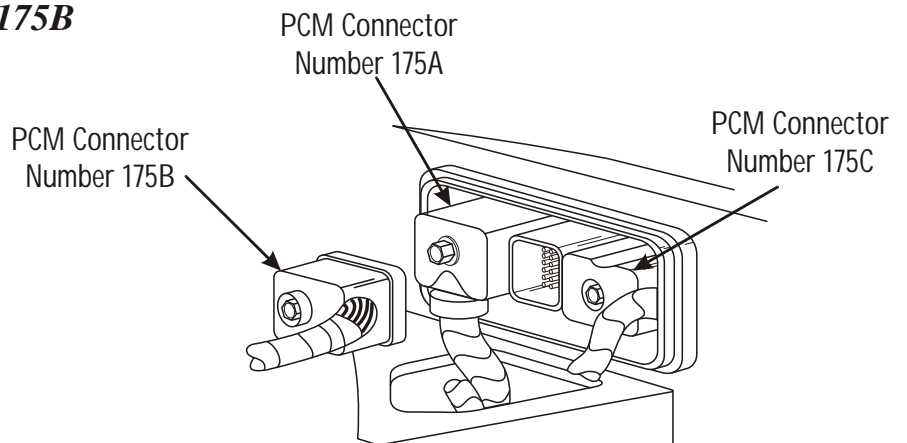
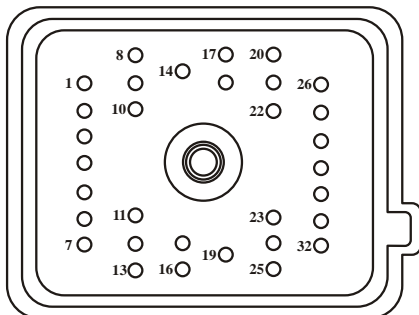

Figure 12

RESISTANCE CHART FOR TRANSMISSION COMPONENTS

COMPONENT RESISTANCE CHART THROUGH PCM CONNECTOR		
<i>Component</i>	<i>Pin Numbers</i>	<i>Resistance</i>
<i>Shift Solenoid "A"</i>	<i>175B, Term 1 and F-37 Cavity</i>	<i>16-45 Ohms</i>
<i>Shift Solenoid "B"</i>	<i>175B, Term 2 and F-37 Cavity</i>	<i>16-45 Ohms</i>
<i>Shift Solenoid "C"</i>	<i>175B, Term 3 and F-37 Cavity</i>	<i>16-45 Ohms</i>
<i>Shift Solenoid "D"</i>	<i>175B, Term 4 and F-37 Cavity</i>	<i>16-45 Ohms</i>
<i>PC Solenoid "A"</i>	<i>175B, Term 7 and F-37 Cavity</i>	<i>3.3-7.5 Ohms</i>
<i>PC Solenoid "B"</i>	<i>175B, Term 13 and F-37 Cavity</i>	<i>3.3-7.5 Ohms</i>
<i>PC Solenoid "C"</i>	<i>175B, Term 12 and F-37 Cavity</i>	<i>3.3-7.5 Ohms</i>
<i>TCC Solenoid</i>	<i>175B, Term 5 and F-37 Cavity</i>	<i>9-16 Ohms</i>
<i>TFT Sensor</i>	<i>175B, Term 17 and Term 23</i>	<i>See Chart Below</i>
<i>Turbine Speed Sensor</i>	<i>175B, Term 17 and Term 27</i>	<i>325-485 Ohms @ 70°F</i>
<i>Intermediate Speed Sensor</i>	<i>175B, Term 17 and Term 21</i>	<i>325-485 Ohms @ 70°F</i>
<i>Output Speed Sensor</i>	<i>175B, Term 17 and Term 26</i>	<i>325-485 Ohms @ 70°F</i>

CASE CONNECTOR PIN IDENTIFICATION AND RESISTANCE CHARTS

<i>Solenoid Resistance Chart</i>		
<i>Component</i>	<i>Connector Terminals</i>	<i>Resistance In Ohms</i>
<i>Shift Solenoid "A"</i>	<i>3 And 16</i>	<i>16-45</i>
<i>Shift Solenoid "B"</i>	<i>3 And 15</i>	<i>16-45</i>
<i>Shift Solenoid "C"</i>	<i>3 And 6</i>	<i>16-45</i>
<i>Shift Solenoid "D"</i>	<i>3 And 5</i>	<i>16-45</i>
<i>Pressure Control Solenoid "A"</i>	<i>3 And 11</i>	<i>3.3-7.5</i>
<i>Pressure Control Solenoid "B"</i>	<i>3 And 1</i>	<i>3.3-7.5</i>
<i>Pressure Control Solenoid "C"</i>	<i>3 And 4</i>	<i>3.3-7.5</i>
<i>TCC Solenoid</i>	<i>3 And 14</i>	<i>9-16</i>
<i>TOT Sensor</i>	<i>2 And 12</i>	<i>See Chart</i>

<i>TFT Sensor Resistance Chart</i>
<i>0°F-31°F = 284k - 100k Ohms</i>
<i>32°F-68°F = 100k - 37k Ohms</i>
<i>69°F-104°F = 37k - 16k Ohms</i>
<i>105°F-158°F = 16k - 5k Ohms</i>
<i>159°F-194°F = 5k - 2.7k Ohms</i>
<i>195°F-230°F = 2.7k - 1.5k Ohms</i>
<i>231°F-266°F = 1.5k - 0.8k Ohms</i>
<i>267°F-302°F = 0.8k - 0.54k Ohms</i>

Transmission
Case Connector

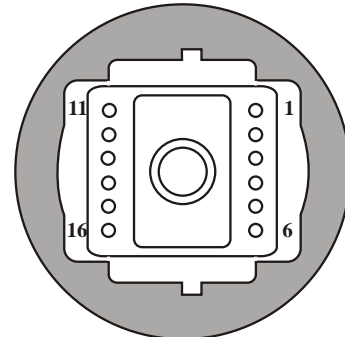

Copyright © 2004 ATSG

Figure 13



Technical Service Information

DIAGNOSTIC TROUBLE CODE (DTC) CHART AND DESCRIPTIONS	
DTC	DESCRIPTION
P0102	<i>Mass Air Flow (MAF) sensor system concerns</i>
P0103	<i>Mass Air Flow (MAF) sensor system concerns</i>
P0112	<i>Intake Air Temperature (IAT) sensor indicates 254°F (Grounded Circuit)</i>
P0113	<i>Intake Air Temperature (IAT) sensor indicates -40°F (Open Circuit)</i>
P0114	<i>Intake Air Temperature (IAT) sensor out of "On-Board Diagnostic" range</i>
P0116	<i>Engine Coolant Temperature (ECT) sensor out of "On-Board Diagnostic" range</i>
P0117	<i>Engine Coolant Temperature (ECT) sensor indicates 254°F (Grounded Circuit)</i>
P0118	<i>Engine Coolant Temperature (ECT) sensor indicates -40°F (Open Circuit)</i>
P0121	<i>Throttle Position (TP) sensor system intermittent</i>
P0122	<i>Throttle Position (TP) sensor signal less than self test minimum</i>
P0123	<i>Throttle Position (TP) sensor signal more than self test maximum</i>
P0300	<i>Electronic Ignition (EI) multiple cylinder miss-fire or defective crank sensor</i>
P0308	<i>Electronic Ignition (EI) misfire cylinder 8</i>
P0320	<i>Electronic Ignition (EI) two successive erratic PIP pulses have occurred</i>
P0340	<i>Electronic Ignition (EI) camshaft position sensor fault</i>
P0500	<i>Vehicle Speed Sensor (VSS), insufficient input from ABS through SCP link</i>
P0503	<i>Vehicle Speed Sensor (VSS), poor performance or noisy signal</i>
P0705	<i>Digital Transmission Range (DTR) sensor circuit failure</i>
P0708	<i>Digital Transmission Range (DTR) sensor circuit TR3A Open</i>
P0712	<i>Transmission Fluid Temperature (TFT) circuit grounded, 315°F indicated</i>
P0713	<i>Transmission Fluid Temperature (TFT) circuit open, -40°F indicated</i>
P0715	<i>Turbine Shaft Speed (TSS) sensor, insufficient input</i>
P0717	<i>Turbine Shaft Speed (TSS) intermittent sensor signal</i>
P0718	<i>Turbine Shaft Speed (TSS) sensor signal noisy</i>
P0720	<i>Output Shaft Speed (OSS) sensor, insufficient input</i>
P0721	<i>Output Shaft Speed (OSS) sensor signal noisy</i>
P0722	<i>Output Shaft Speed (OSS) intermittent sensor signal</i>
P0731	<i>Gear Ratio Error, 1st Gear</i>
P0732	<i>Gear Ratio Error, 2nd Gear</i>
P0733	<i>Gear Ratio Error, 3rd Gear</i>
P0734	<i>Gear Ratio Error, 4th Gear</i>
P0735	<i>Gear Ratio Error, 5th Gear</i>
P0740	<i>Torque Converter Clutch (TCC) circuit open or shorted</i>
P0741	<i>Torque Converter Clutch (TCC) slippage detected</i>

Copyright © 2004 ATSG

Figure 14



Technical Service Information

DIAGNOSTIC TROUBLE CODE (DTC) CHART AND DESCRIPTIONS	
DTC	DESCRIPTION
P0743	<i>Torque Converter Clutch (TCC) solenoid circuit failure during KOEO test</i>
P0745	<i>Pressure Control "A" (PCA) solenoid, shorted circuit</i>
P0748	<i>Pressure Control "A" (PCA) solenoid, mechanical failure</i>
P0750	<i>Shift Solenoid "A" (SSA) circuit failure during KOEO test</i>
P0753	<i>Shift Solenoid "A" (SSA) circuit failure open or shorted</i>
P0755	<i>Shift Solenoid "B" (SSB) circuit failure during KOEO test</i>
P0758	<i>Shift Solenoid "B" (SSB) circuit failure open or shorted</i>
P0760	<i>Shift Solenoid "C" (SSC) circuit failure during KOEO test</i>
P0763	<i>Shift Solenoid "C" (SSC) circuit failure, open or shorted</i>
P0765	<i>Shift Solenoid "D" (SSD) circuit failure during KOEO test</i>
P0768	<i>Shift Solenoid "D" (SSD) circuit failure open or shorted</i>
P0775	<i>Pressure Control "B" (PCB) solenoid, shorted circuit</i>
P0778	<i>Pressure Control "B" (PCB) solenoid, mechanical failure</i>
P0779	<i>Pressure Control "B" (PCB) solenoid, intermittent short to ground</i>
P0791	<i>Intermediate Shaft Speed (ISS) sensor signal failure</i>
P0794	<i>Intermediate Shaft Speed (ISS) sensor signal intermittent</i>
P0795	<i>Pressure Control "C" (PCC) solenoid, shorted circuit</i>
P0796	<i>Pressure Control "C" (PCC) solenoid, open circuit</i>
P0797	<i>Pressure Control "C" (PCC) solenoid failure</i>
P0798	<i>Pressure Control "C" (PCC) solenoid, mechanical failure</i>
P0799	<i>Pressure Control "C" (PCC) solenoid, intermittent short to ground</i>
P0960	<i>Pressure Control "A" (PCA) solenoid, circuit open</i>
P0962	<i>Pressure Control "A" (PCA) solenoid, shorted to ground</i>
P0963	<i>Pressure Control "A" (PCA) solenoid, intermittent short to power or ground</i>
P0964	<i>Pressure Control "B" (PCB) solenoid, open circuit</i>
P0966	<i>Pressure Control "B" (PCB) solenoid, shorted to ground</i>
P0967	<i>Pressure Control "B" (PCB) solenoid, intermittent short to power or ground</i>
P0968	<i>Pressure Control "C" (PCC) solenoid, open circuit</i>
P0970	<i>Pressure Control "C" (PCC) solenoid, shorted to ground</i>
P0971	<i>Pressure Control "C" (PCC) solenoid, intermittent short to power or ground</i>
P1100	<i>Mass Air Flow (MAF) sensor, circuit intermittent voltage input</i>
P1101	<i>Mass Air Flow (MAF) sensor, signal was not 0.34-1.96 during self test</i>
P1120	<i>Throttle Position (TP) sensor signal went to less than .49 volts</i>
P1121	<i>Throttle Position (TP) sensor signal inconsistant with MAF signal</i>

Copyright © 2004 ATSG

Figure 15

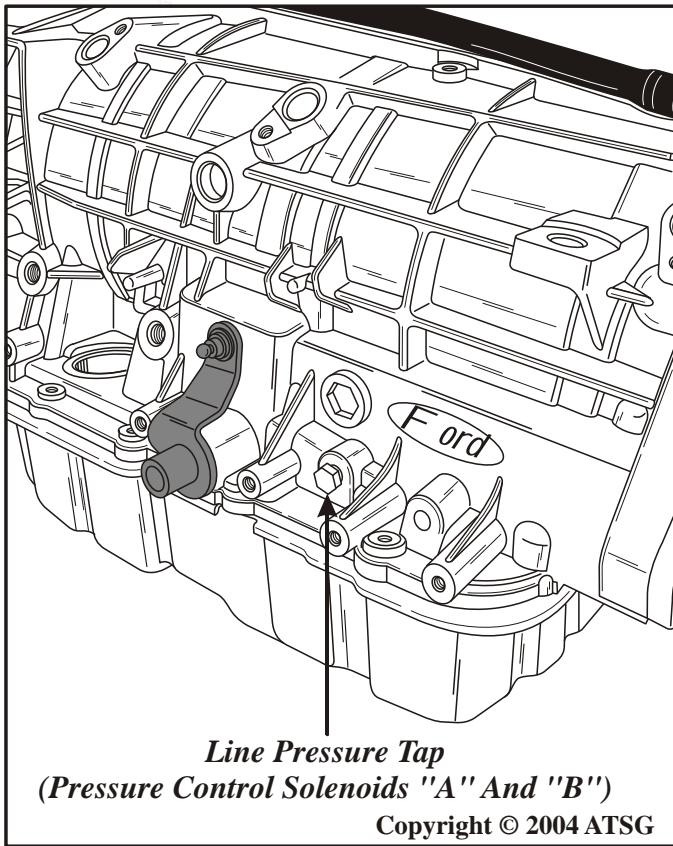

Figure 17

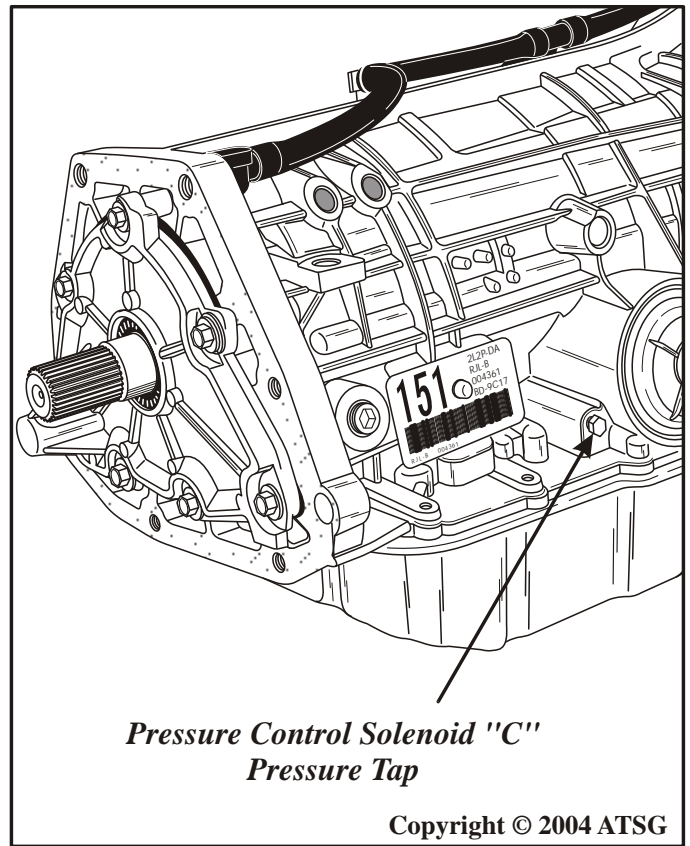

Figure 18

LINE PRESSURE TEST

1. There are 3 Pressure Control solenoids located in the solenoid body, PC "A", PC "B", PC "C", used to control all application pressures.
2. Start engine and check line pressures using the chart provided below to determine if the line pressure is within specifications.

Special Note: The line pressure tap in Figure 17, is used to verify output pressure from PC "A" or from PC "B", by turning either one OFF while verifying pressure from the other solenoid.

The 2nd pressure tap in Figure 18, is used to verify pressure readings from PC "C" solenoid. Use the chart below for proper specifications.

Vehicle/Engine	Range	Idle Line Pres.	WOT Line Pres.	Idle PC "C" Pres.	WOT PC "C" Pres.
Explorer/Mountaineer, 4.0L Engine	P/N	90-120 psi	---	0-15 psi	---
	Reverse	100-140 psi	282-380 psi	90-120 psi	112-134 psi
	(D), 3, 2, 1	90-110 psi	228-263 psi	0-15 psi	0-15 psi
Explorer/Mountaineer, 4.6L Engine	P/N	90-120 psi	---	0-15 psi	---
	Reverse	90-120 psi	282-380 psi	90-120 psi	112-134 psi
	(D), 3, 2, 1	80-110 psi	228-263 psi	0-15 psi	0-15 psi

Figure 19

FORD 5R55S/W CHECKING FLUID LEVEL

Checking the fluid level on any vehicle equipped with Ford Motor Company's new 5R55W/S transmission may become confusing to some technicians. There is a plug on the right rear of the transmission case, as shown in Figure 22, that would lead one to believe that this is where you check the fluid level, since some of the other manufacturers are currently checking fluid level in this manner.

However, this is a **"Fill" plug only** on the new 5R55W/S transmission from Ford Motor Company, which is currently found in the Explorer and Mountaineer vehicles. To **"Check"** for the correct fluid level, you must remove the **check plug**, which is located in the center of the bottom pan drain plug, and is removed with an allen wrench, as shown in Figure 22, while holding the drain plug with the proper size wrench so as not to loosen the drain plug.

We have provided you with a cut-away drawing of the bottom oil pan and the drain plug so that you will understand how this system works. Notice that the drain plug actually has a "stem" made on it that extends some distance up into the bottom pan, which is now our way to establish the proper fluid level in the transmission. By removing the "Check" plug from the "Drain" plug, the fluid should just trickle over the stem and out through the center of the drain plug, as shown in Figure 22. The **"Fill"** plug in the right rear of the case is your **only** way to replace and/or fill with fluid, in the 5R55W/S transmission.

We have also identified the cooler line fittings and lines, as shown in Figure 21.

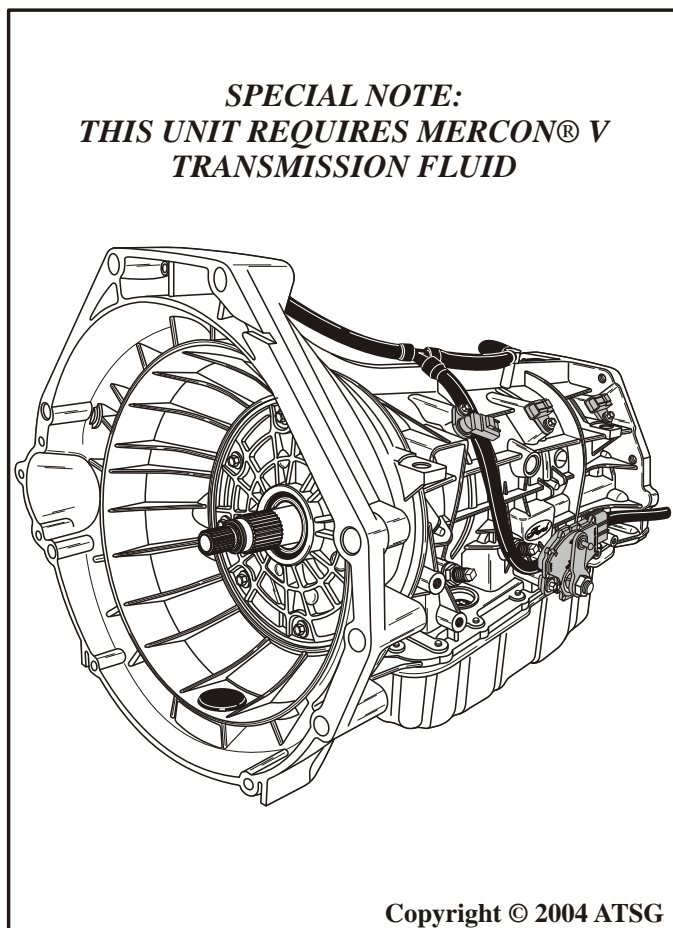

Figure 20

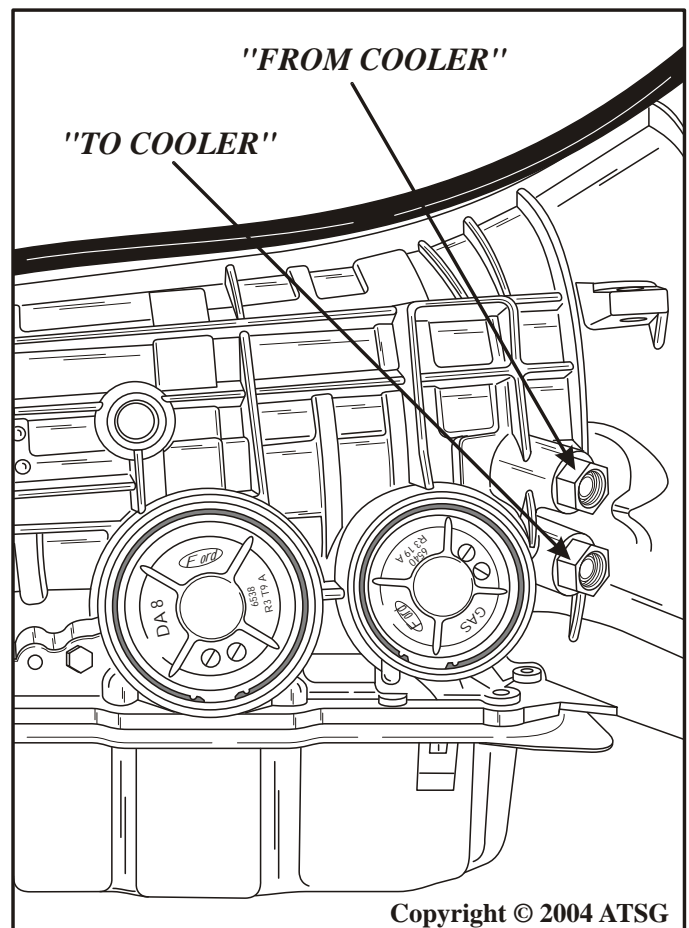
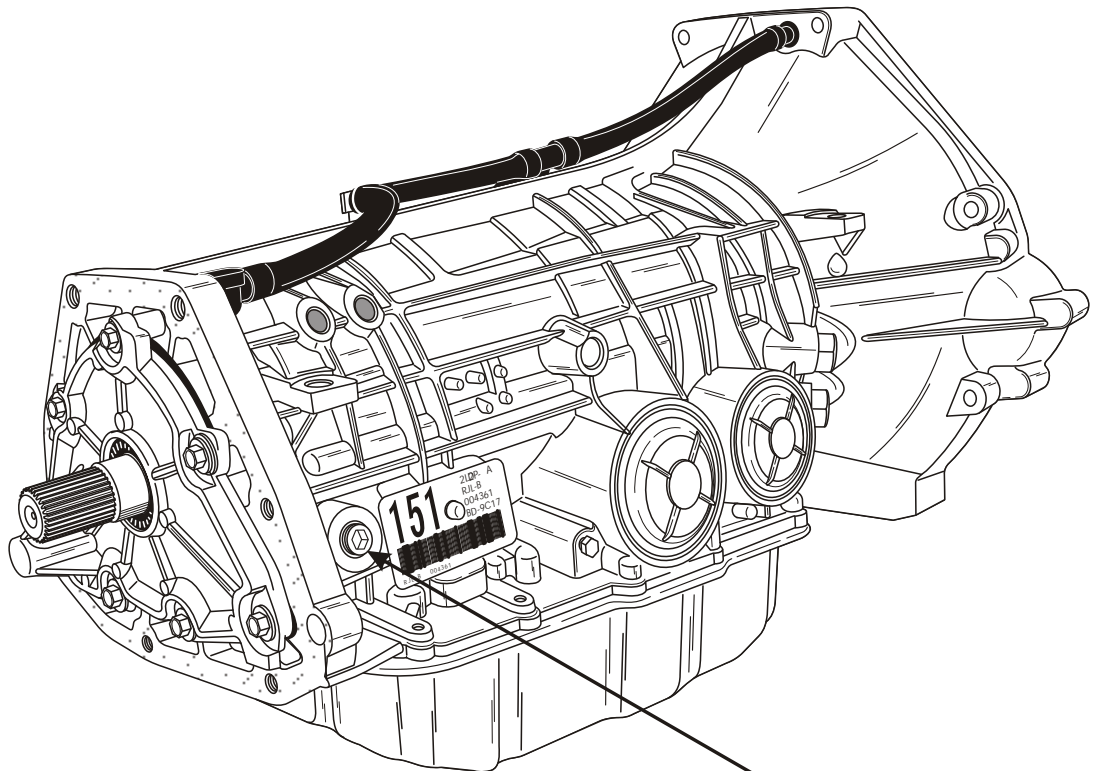
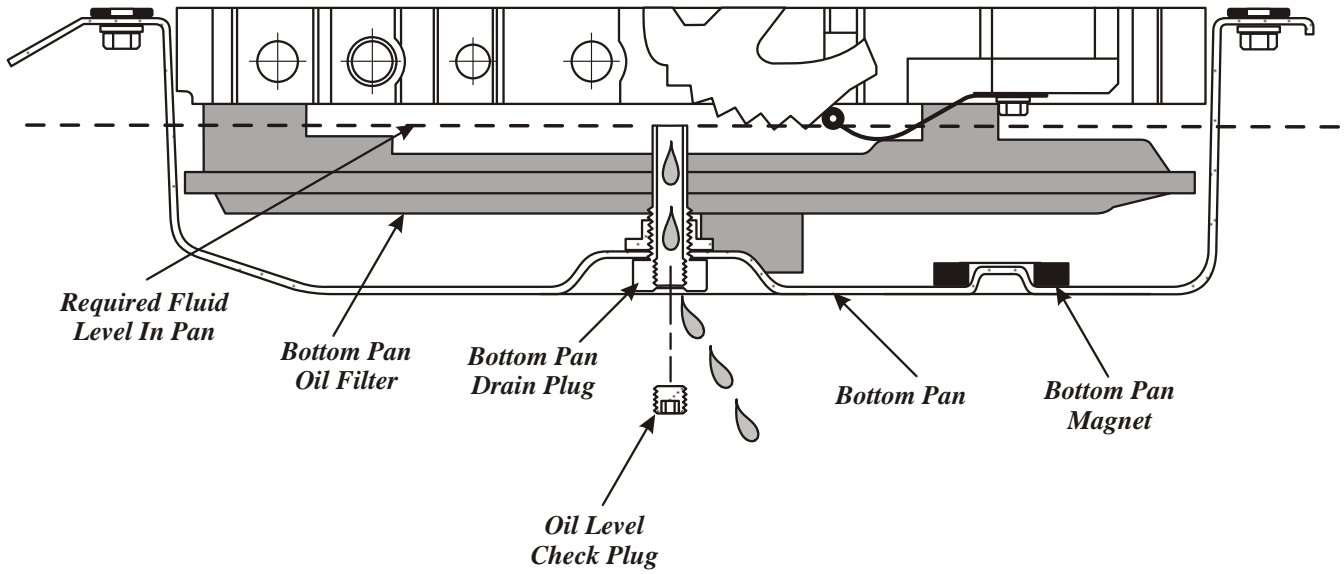

Figure 21

CHECKING FLUID LEVEL



THIS IS A "FILL" PLUG ONLY

Figure 22

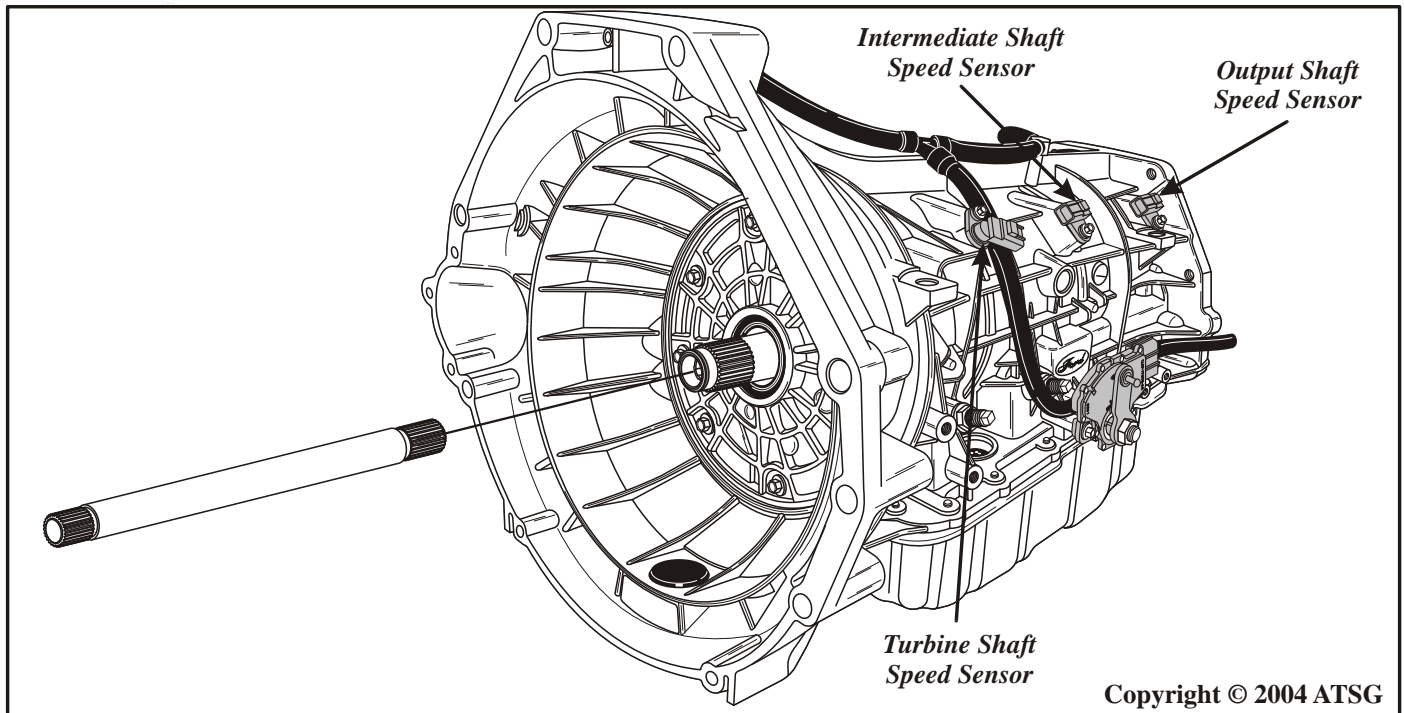

Figure 23

TRANSMISSION DISASSEMBLY

EXTERNAL COMPONENTS

1. Remove the turbine shaft from the transmission as shown in Figure 23. Inspect the spline area on both ends and set aside for final assembly.
2. Remove the Turbine Shaft Sensor (TSS), the Intermediate Shaft Sensor (ISS) and the Output Shaft Sensor (OSS) from the transmission case, using a 30 Torx bit for the retaining bolts. (See Figure 23).
3. The Turbine and Output sensors are exactly the same part number. Refer to Figure 24 for the differences between them, and the Intermediate shaft speed sensor.
4. Remove and discard the "O" ring seals from all three speed sensors, and use the chart found in Figure 13 to ohms check the sensors for proper resistance readings.

Continued on Page 25

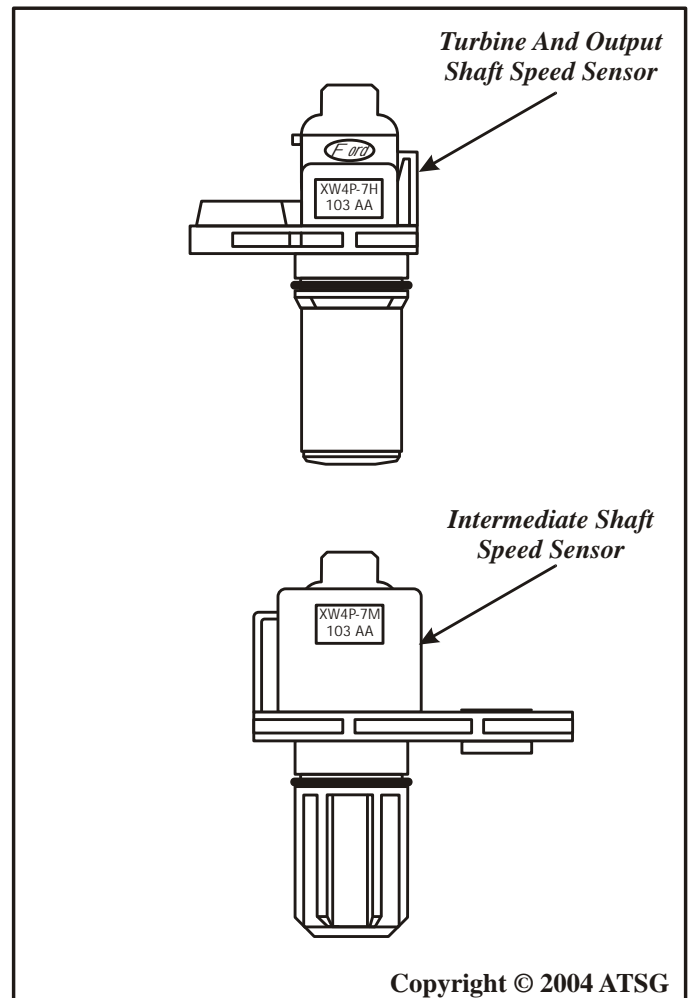

Figure 24

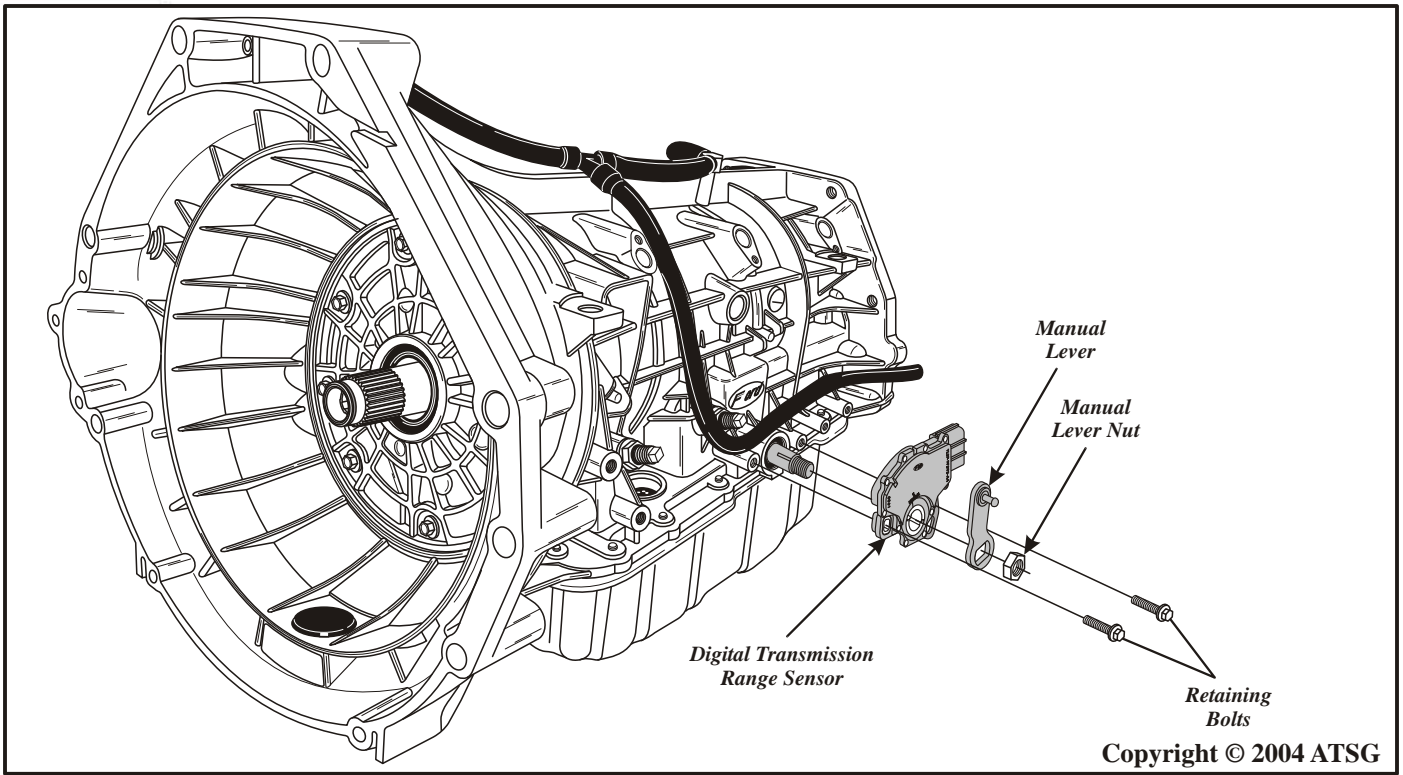

Figure 25

EXTERNAL COMPONENTS (Cont'd)

5. Remove the manual lever retaining nut and the manual lever, as shown in Figure 25.
6. Remove the two Digital Transmission Range sensor retaining bolts, as shown in Figure 25, and remove the sensor.
7. Install a compatible holding fixture onto the transmission case, as shown in Figure 26, that will allow you to rotate the transmission when installed in the bench fixture.
8. Install the transmission into the bench fixture and rotate, so that the bottom pan is facing up, as shown in Figure 27.

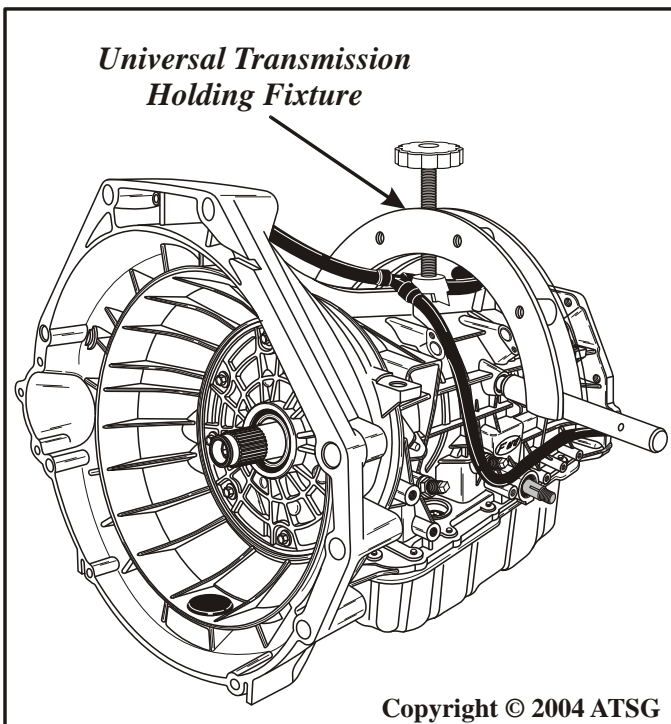

Figure 26

Continued on Page 26

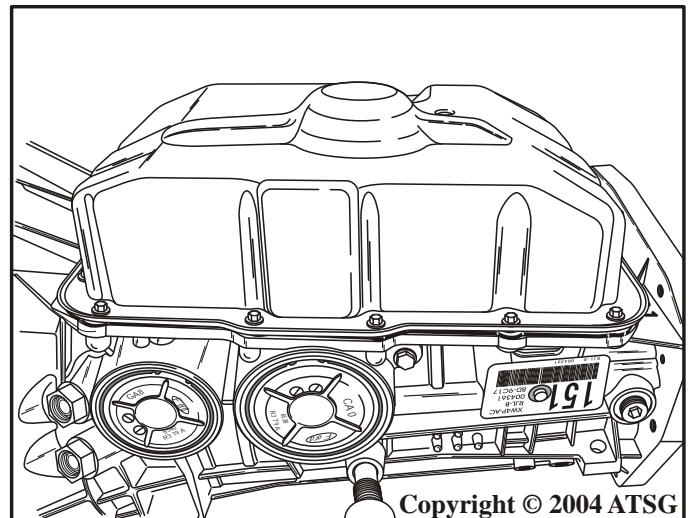

Figure 27

EXTERNAL COMPONENTS (Cont'd)

9. Rotate the transmission so that the bottom pan is facing up, as shown in Figure 27.
10. Remove the sixteen bottom pan bolts using an 8mm socket and remove oil pan, as shown in Figure 28.
11. Remove the bottom pan gasket from the case, as shown in Figure 28.
Note: The bottom pan gasket is reuseable. Clean and inspect the gasket for damage, and if it is not damaged, it may be re-used.
12. Remove the two filter retaining bolts, as shown in Figure 29, and remove and discard the oil filter and seals.
13. Remove the four rear servo retaining bolts and remove the Low/Reverse Servo assembly, as shown in Figure 30.
14. Set the Low/Reverse Servo assembly aside for the component rebuild process.

15. Remove the eight solenoid body retaining bolts using a 30 Torx bit, as shown in Figure 30.
16. Remove the solenoid body assembly from the transmission, as shown in Figure 30, and set aside for testing in component rebuild.

Continued on Page 28

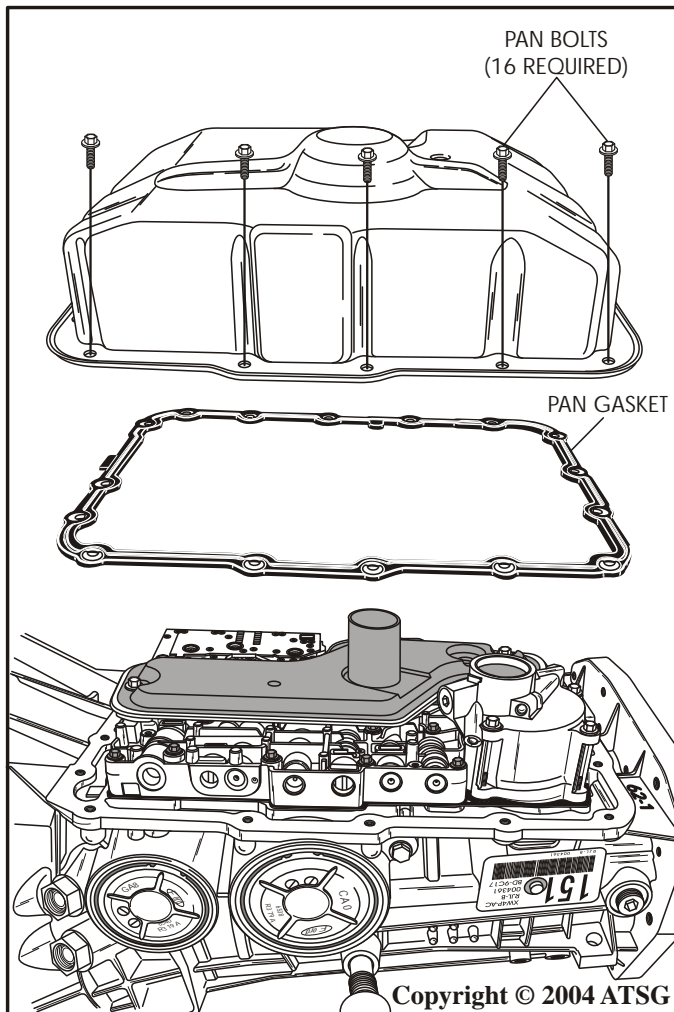

Figure 28

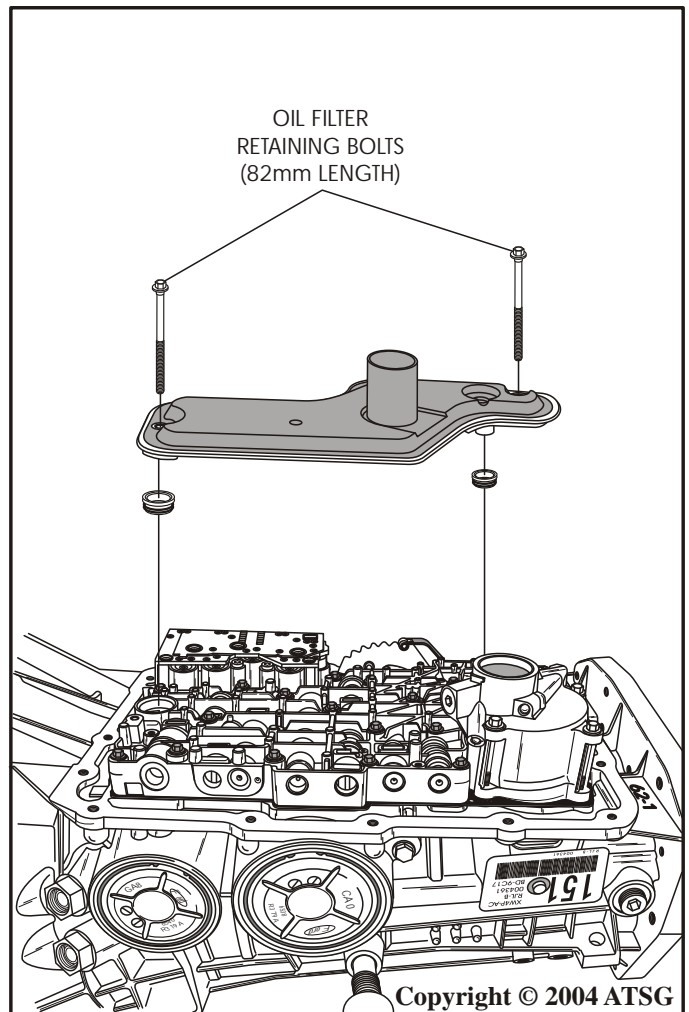

Figure 29

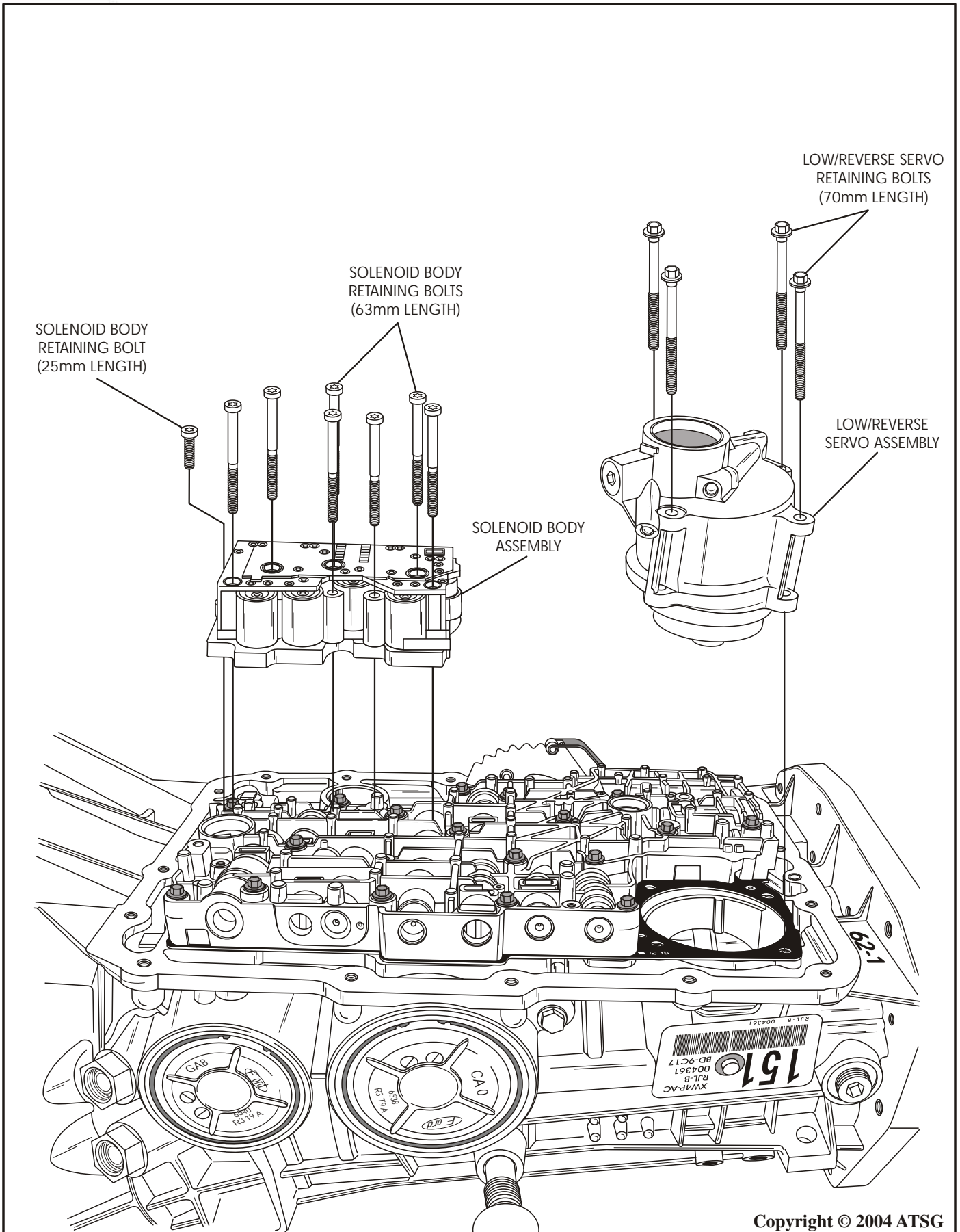
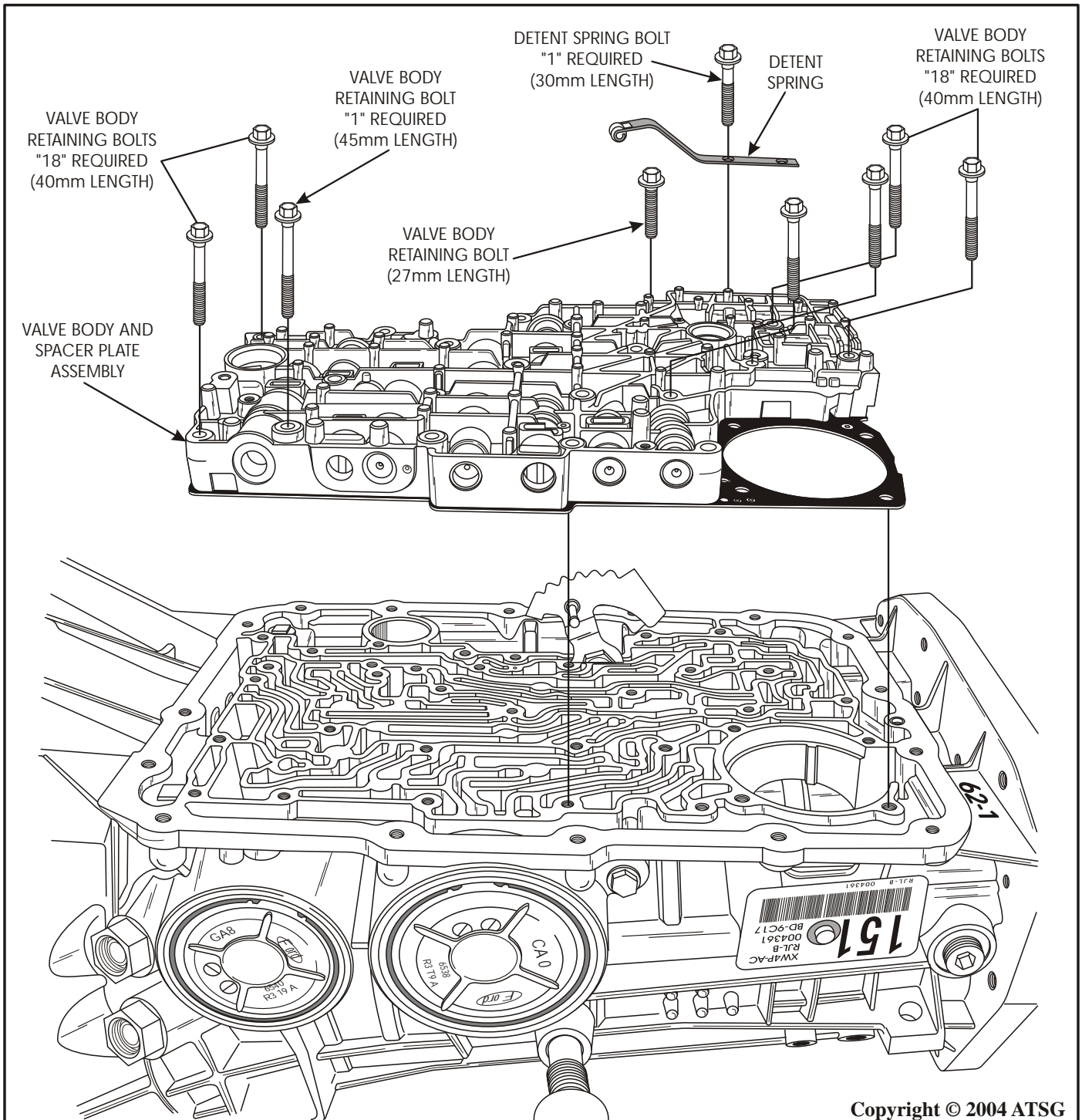

Figure 30

EXTERNAL COMPONENTS (Cont'd)

17. Remove the detent spring retaining bolt and the detent spring, as shown in Figure 31.
- Note: This is the only valve body retaining bolt that is 30mm in length.**
18. Remove the only 45mm in length valve body bolt, as shown in Figure 31, **and note location.**

19. Remove the only 27mm in length valve body bolt, as shown in Figure 31, **and note location.**
20. Remove the remaining 18 valve body retaining bolts as shown in Figure 31, and they are all 40mm in length.
21. Remove valve body and spacer plate assembly, as shown in Figure 31, and set aside for the component rebuild section.



Copyright © 2004 ATSG

Figure 31

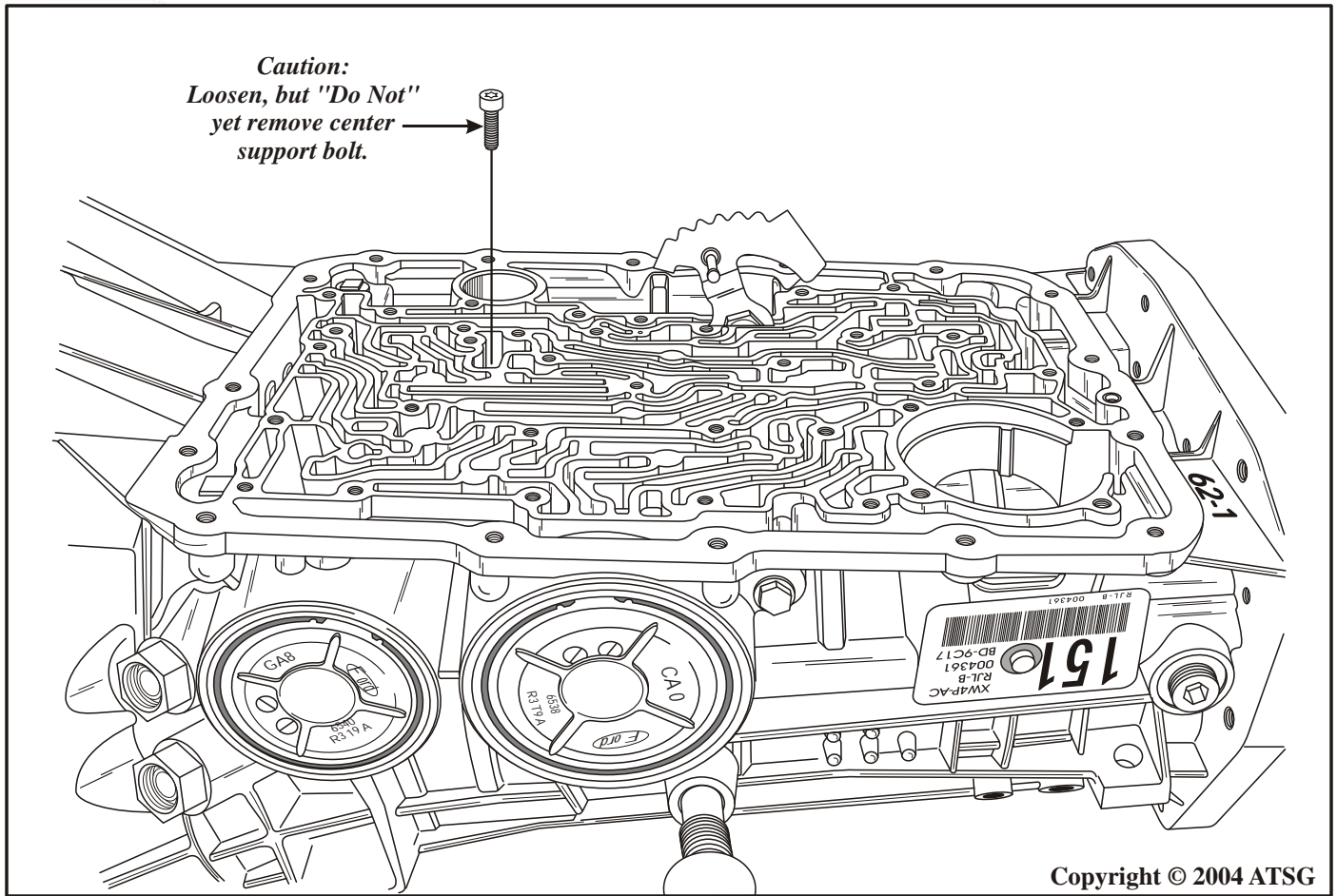

Figure 32

EXTERNAL COMPONENTS (Cont'd)

22. Loosen, **but do not remove**, the center support retaining bolt (See Figure 32).
23. Loosen both band adjusting screws, as shown in Figure 33.
24. **Caution: Failure to loosen OD band adjusting screw prior to pump removal may cause damage to the pump or OD band.**
25. Remove and discard the locknuts from the band adjusting screws, as they are not reusable.

Continued on Page 30

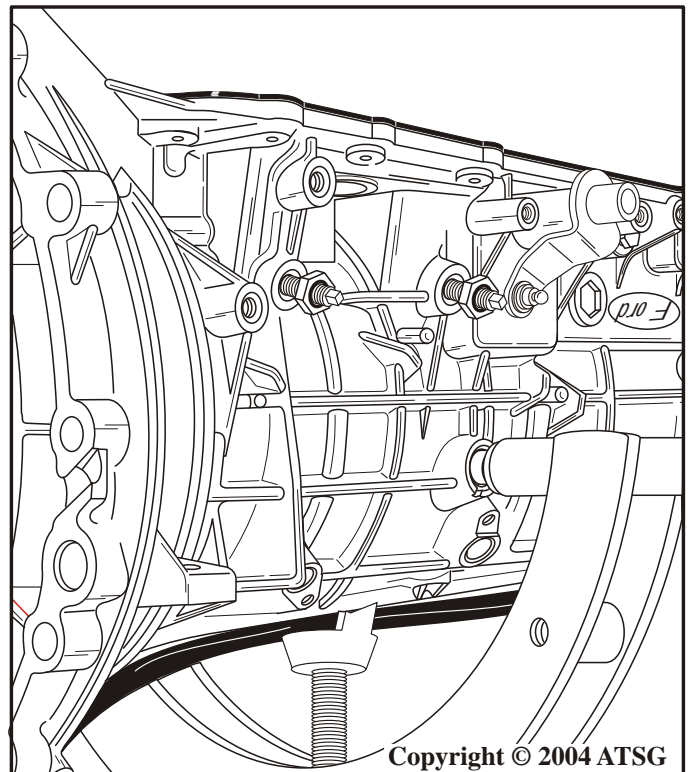

Figure 33

INTERNAL COMPONENTS (Cont'd)

26. Rotate the transmission in bench fixture so that the pump is facing up, as shown in Figure 34.
27. Install the special pump puller, to be used with a slide hammer, as shown in Figure 35.
28. Remove the eight oil pump retaining bolts, as shown in Figure 36.

Note: Ford Motor Co. recommends that the pump bolts not be reused, but replaced.

Continued on Page 32

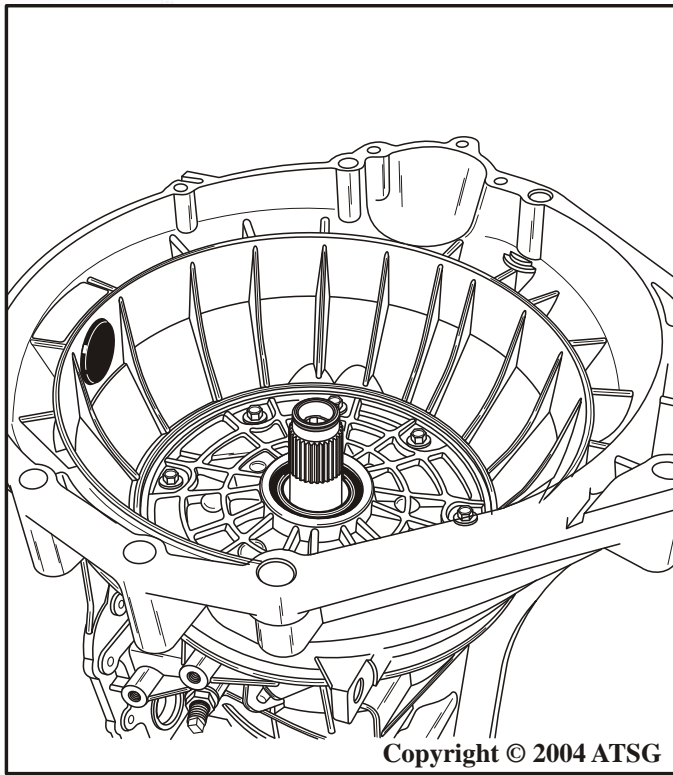

Figure 34

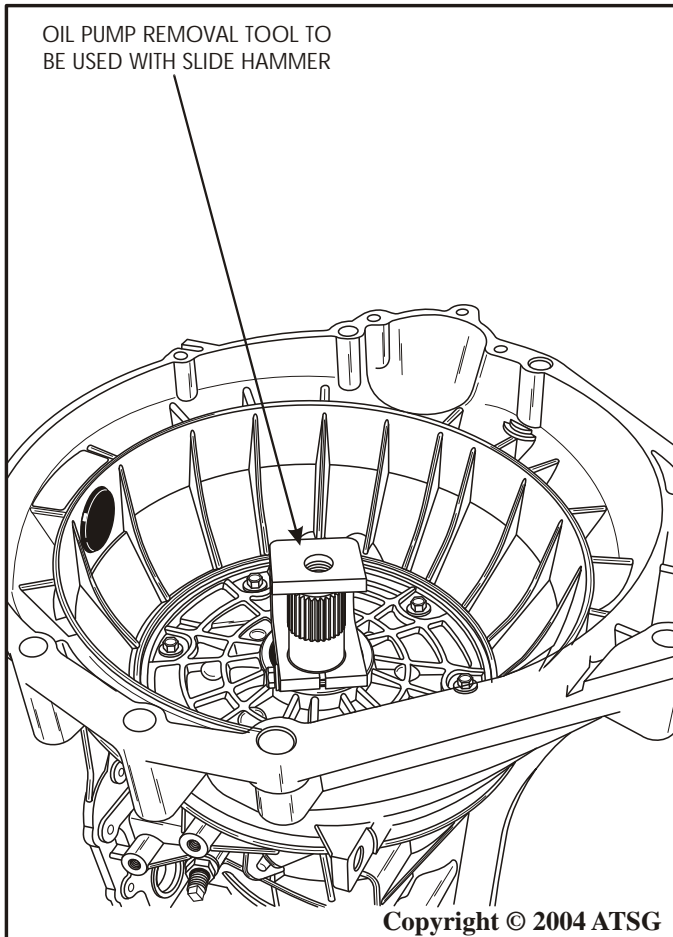

Figure 35

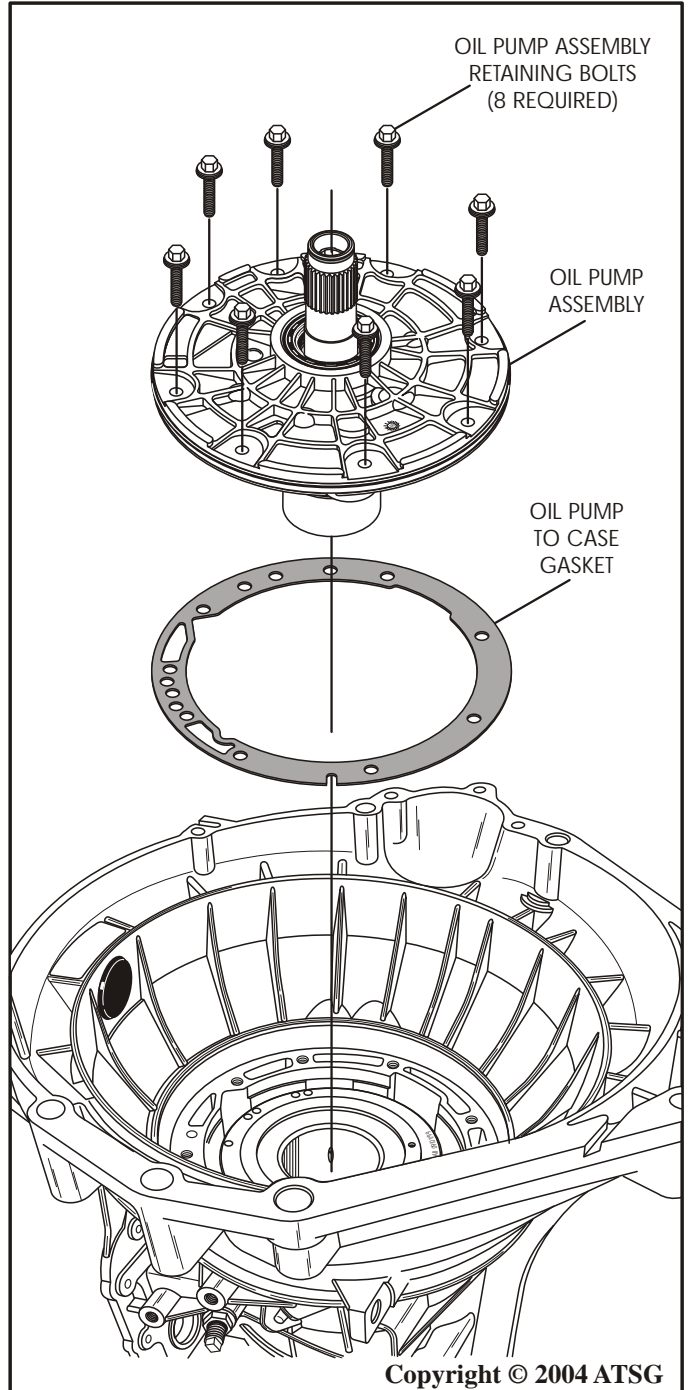

Figure 36

INTERNAL COMPONENTS (Cont'd)

29. Using the special pump removal tool and your slide hammer, remove the oil pump assembly, as shown in Figure 36.
30. Set the oil pump assembly aside for component rebuild section in this manual.
31. Remove the OD/Coast clutch drum assembly, as shown in Figure 37, and set drum aside for the component rebuild section.
32. Remove the overdrive band assembly and both band struts, as shown in Figure 38.
Note: Notice the difference in the band struts and which side they are located, as shown in Figure 38.
33. Remove the coast clutch drum adapter and the overdrive sun gear from the overdrive carrier, as shown in Figure 39.

Continued on Page 32

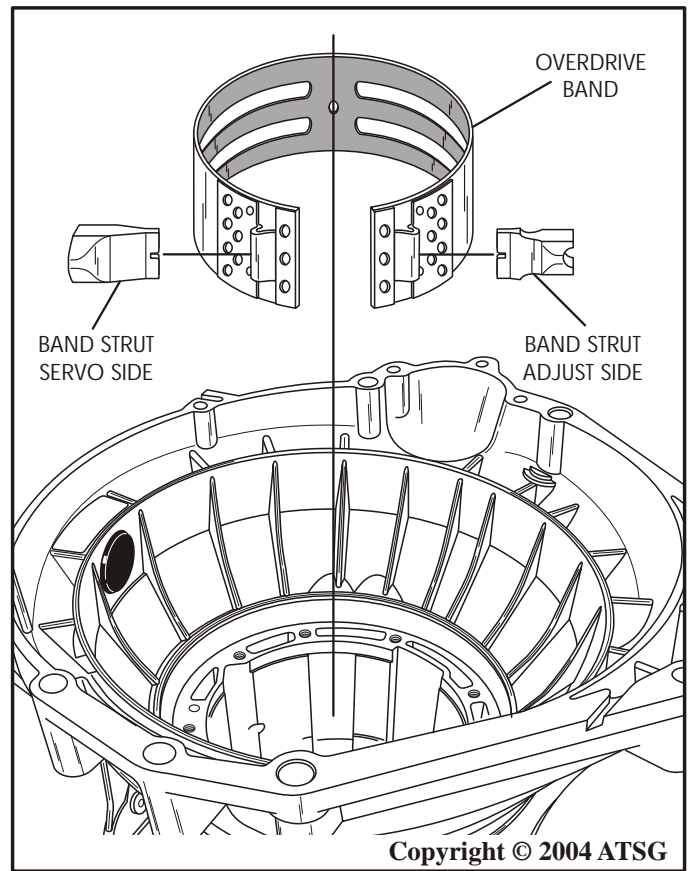

Figure 38

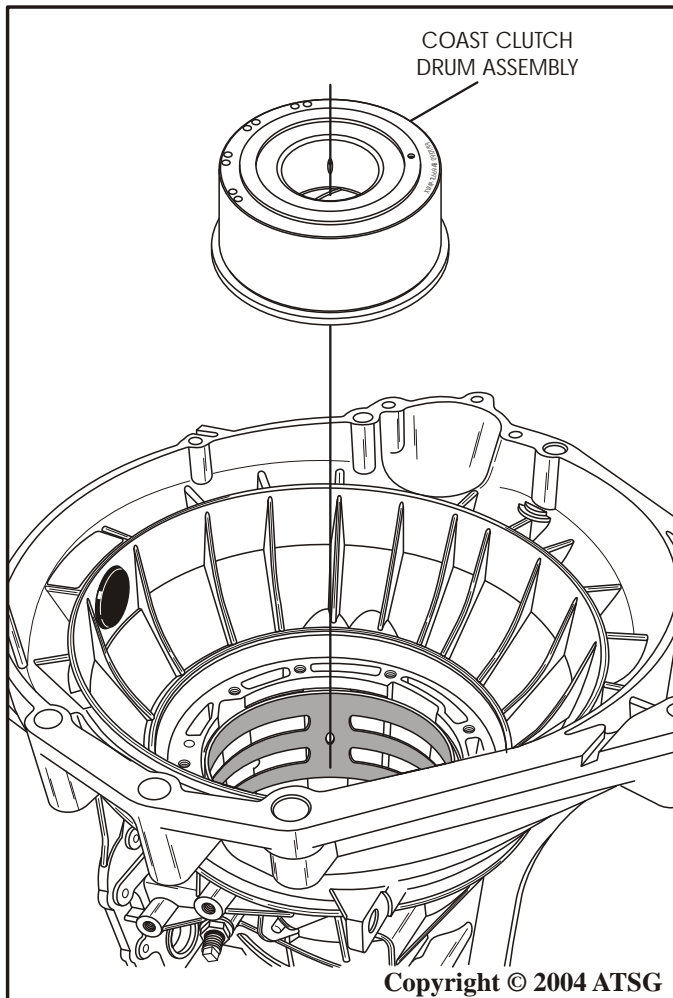

Figure 37

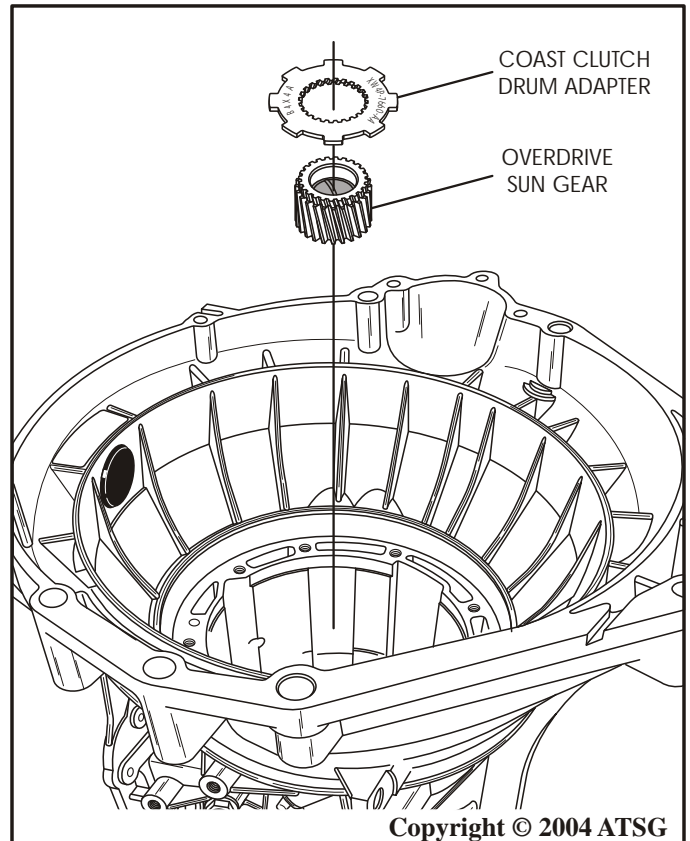

Figure 39

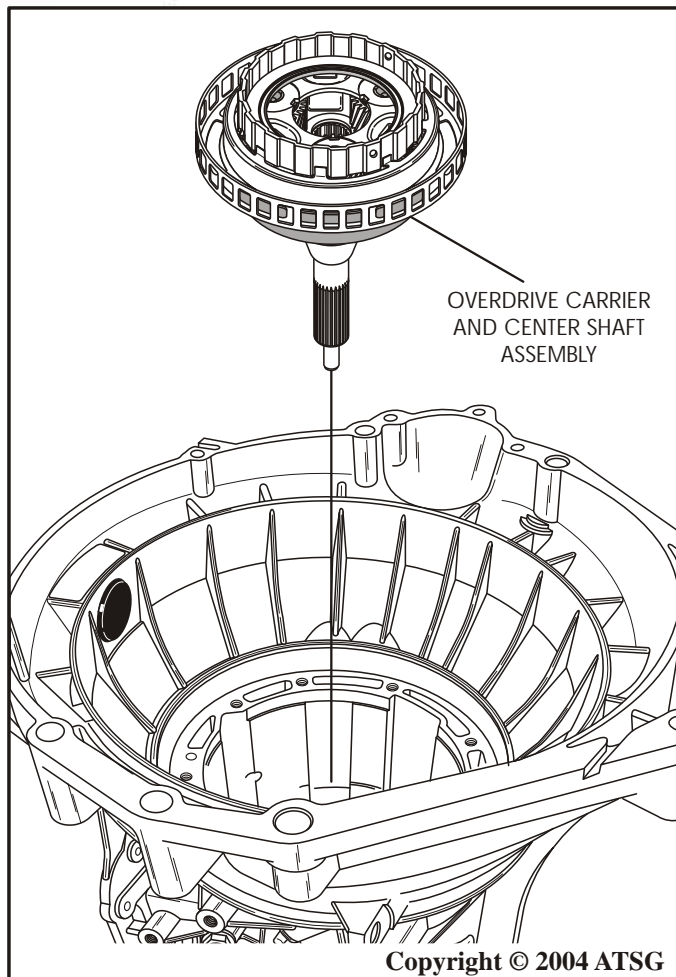

Figure 40

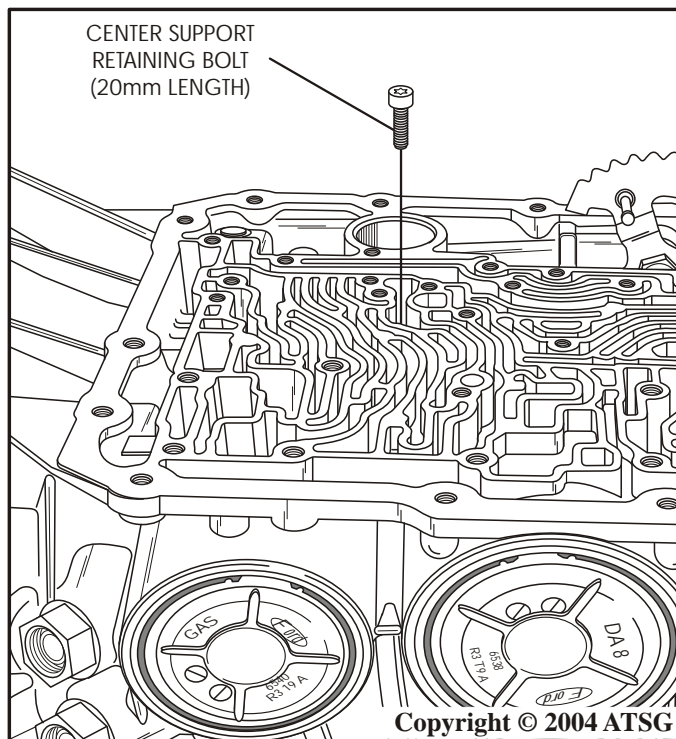

Figure 41

INTERNAL COMPONENTS (Cont'd)

34. Remove the overdrive carrier and center shaft assembly, as shown in Figure 40.
35. Now, remove the center support retaining bolt from the case, as shown in Figure 41, and also remove the locknut, as shown in Figure 42, to prevent it from falling into the assembly.
36. Remove the center support retaining snap ring from the case, as shown in Figure 42.
37. Remove center shaft thrust bearing (No. 3) from the center support, as shown in Figure 42 and tag it for I.D. and location.

Continued on Page 33

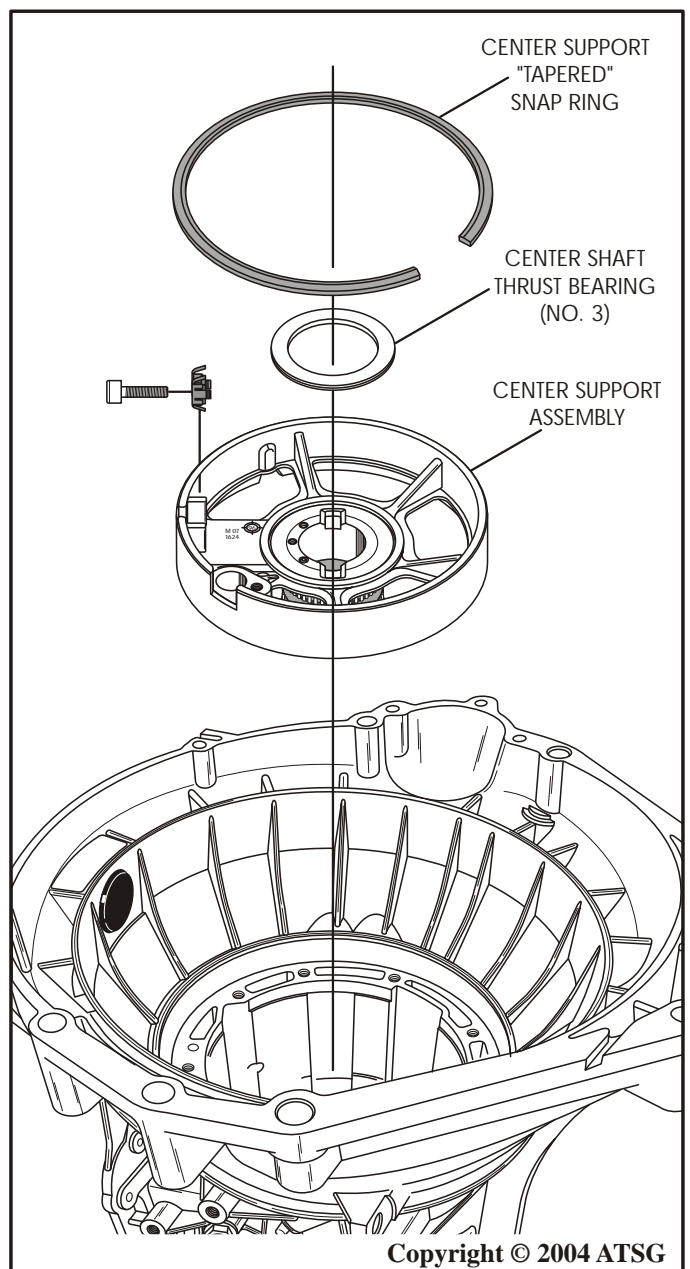

Figure 42

INTERNAL COMPONENTS (Cont'd)

38. Remove the center support and set aside for component rebuild, as shown in Figure 43.
39. Remove the intermediate band assembly and both band struts, as shown in Figure 43.
Note: Notice the difference in the band struts and which side they are located, as shown in Figure 43.
40. Remove and tag for I.D. direct clutch (No. 4) *selective* thrust bearing, as shown in Figure 44.
41. Remove the direct clutch housing assembly and set aside for component rebuild, as shown in Figure 44.
42. Remove and tag for I.D. forward clutch (No. 5) thrust bearing, as shown in Figure 44.
43. Remove the forward clutch housing assembly and set aside for component rebuild, as shown in Figure 44.
44. Remove and tag for I.D. the forward clutch (No. 6A) thrust bearing (See Figure 44).
Note: This bearing may stick to the forward clutch housing during removal.

Continued on Page 34

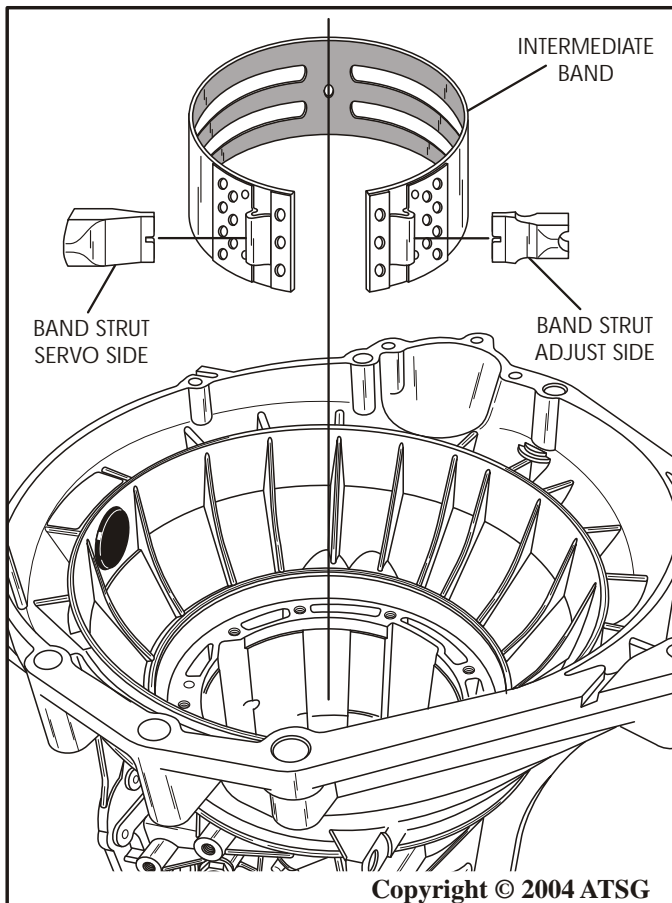

Figure 43

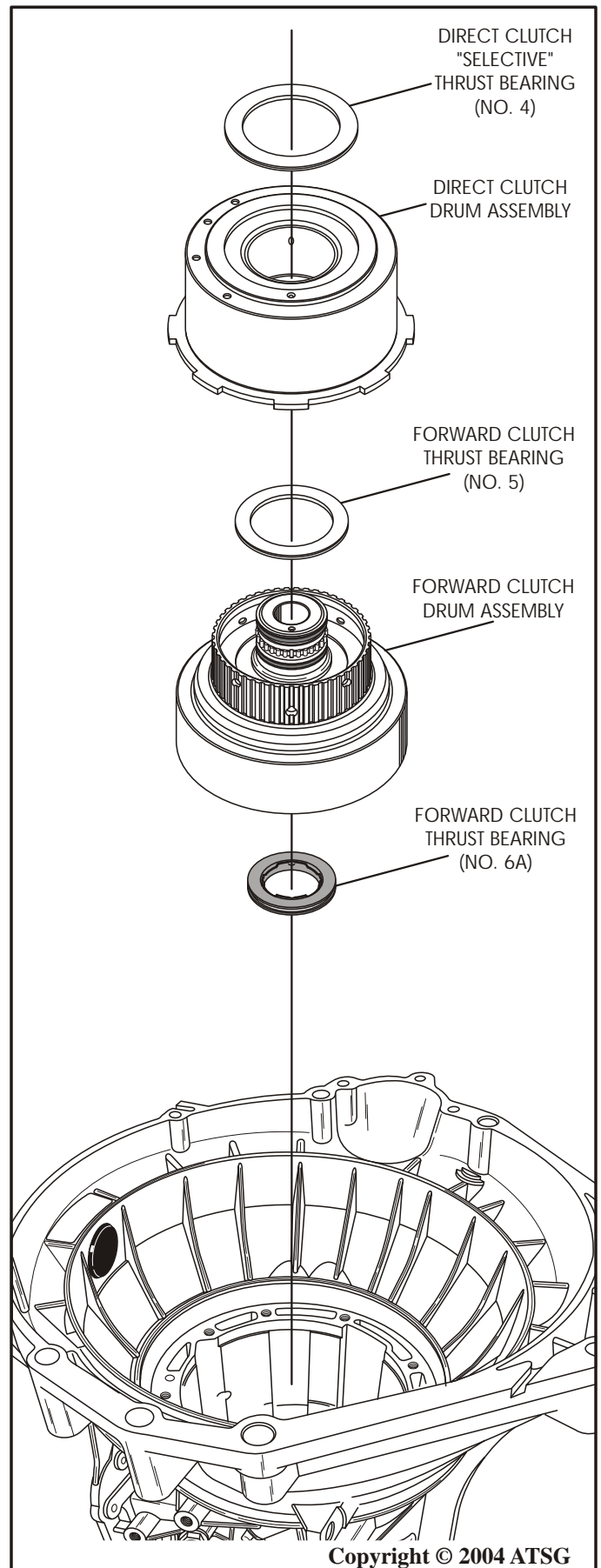

Figure 44

INTERNAL COMPONENTS (Cont'd)

45. Remove forward ring gear and hub assembly along with the forward clutch (No. 6B) thrust washer, as shown in Figure 45.

46. Remove and tag for I.D. the forward planet (No. 7) thrust bearing (See Figure 45).

Note: Bearing may come out with the forward ring gear and hub assembly.

47. Remove the forward planetary carrier assembly as shown in Figure 45, and set aside for the component rebuild section.

48. Remove the input sun gear and shell assembly, as shown in Figure 46.

49. Remove the low/reverse bearing spacer from transmission case, as shown in Figure 46.

50. Remove and tag for I.D. the rear planetary thrust bearing (No. 8), as shown in Figure 47.

51. Remove the rear planetary retaining snap ring from reverse drum, as shown in Figure 47.

Continued on Page 35

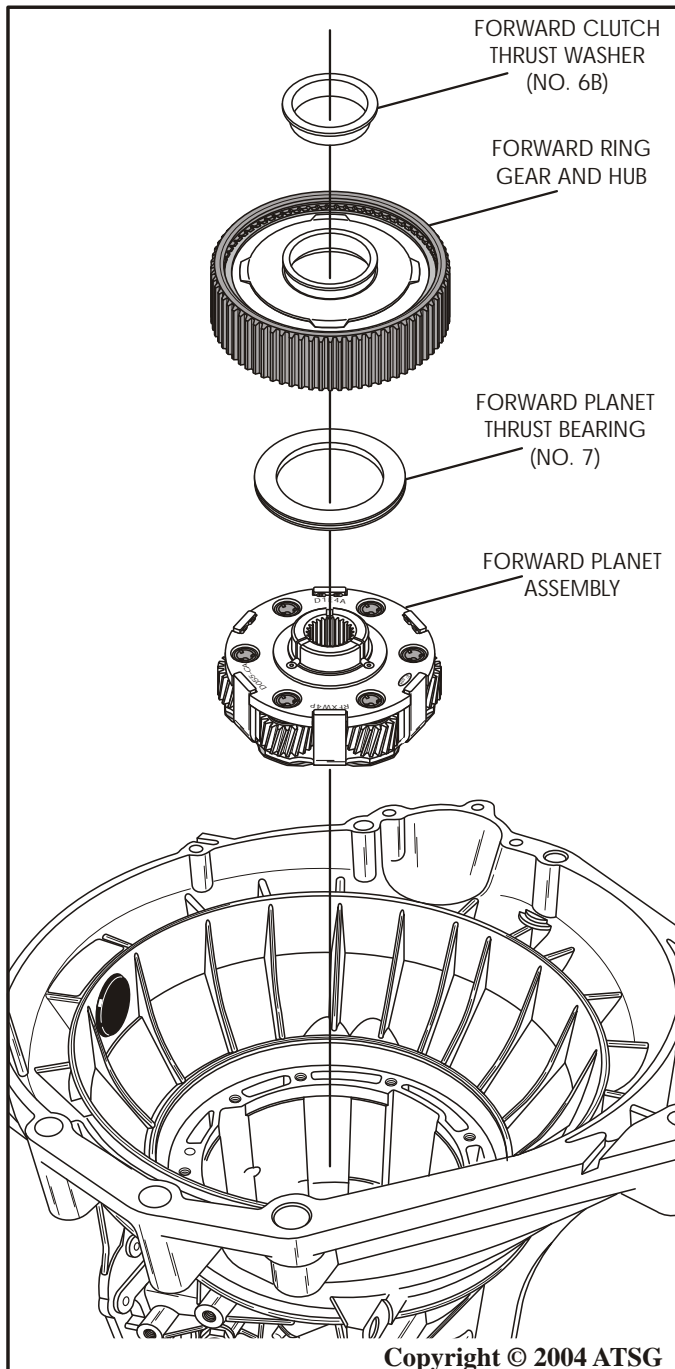

Figure 45

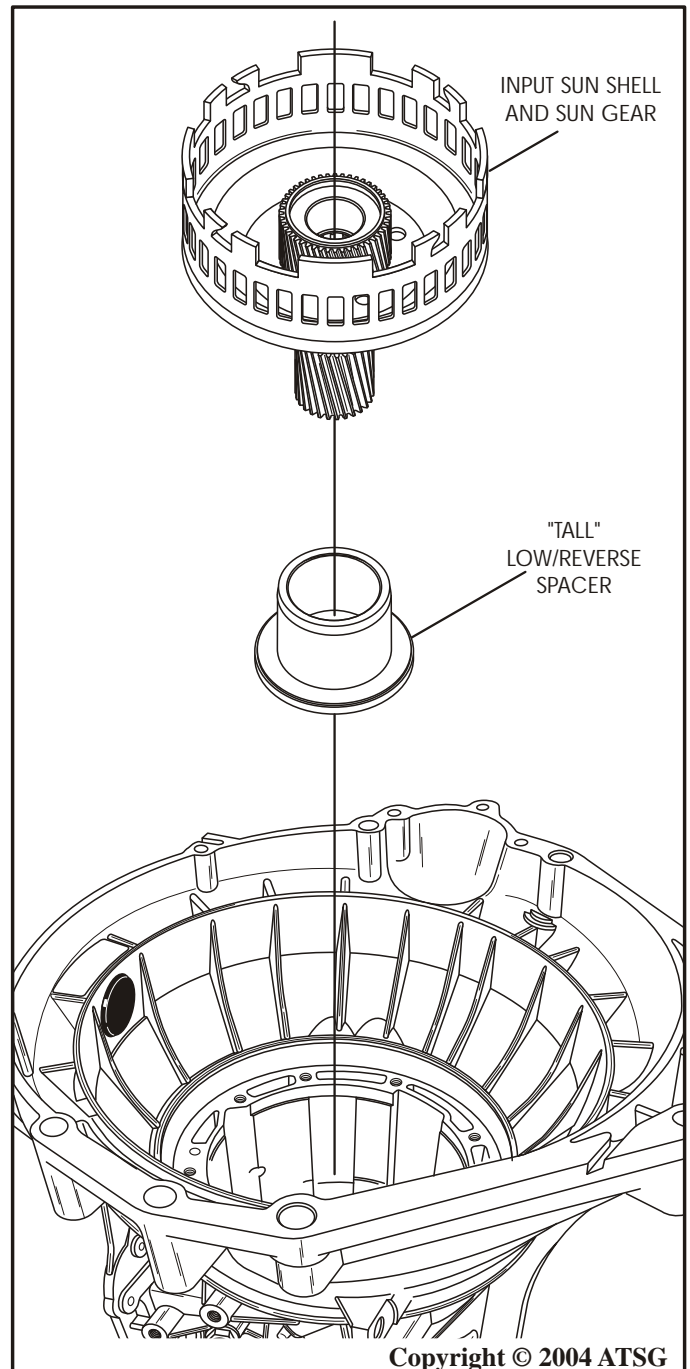

Figure 46

INTERNAL COMPONENTS (Cont'd)

52. Remove the rear planetary carrier from the reverse drum, as shown in Figure 47.
53. Remove the plastic lube dam from the rear planetary ring gear, as shown in Figure 48.
54. Remove the output shaft retaining snap ring from the output shaft, as shown in Figure 48.

Caution: *Install temporary strap on back of case, as shown in Figure 49, to retain the output shaft from falling out, "before" you remove the snap ring.*

Continued on Page 36

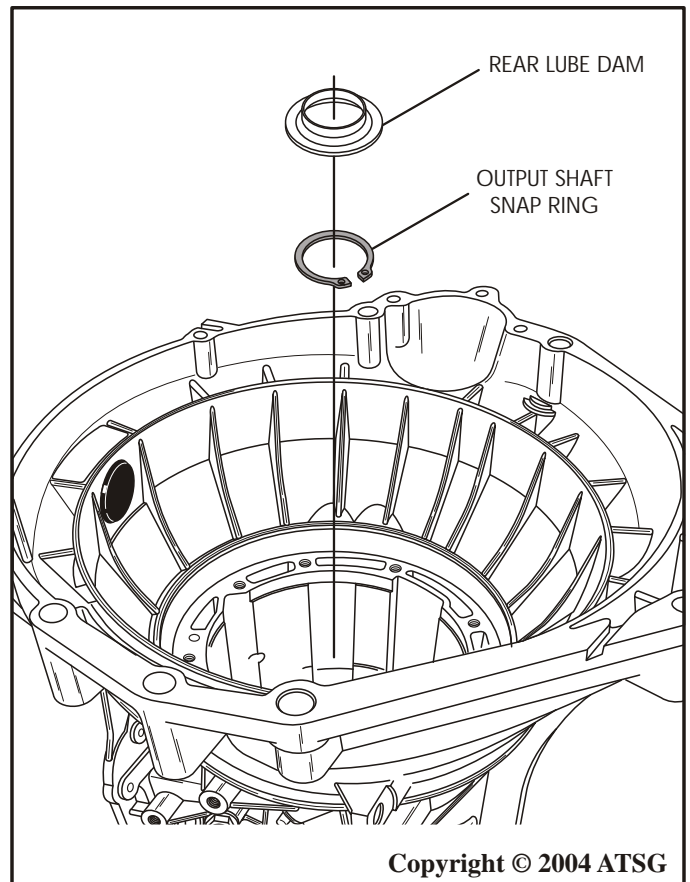

Figure 48

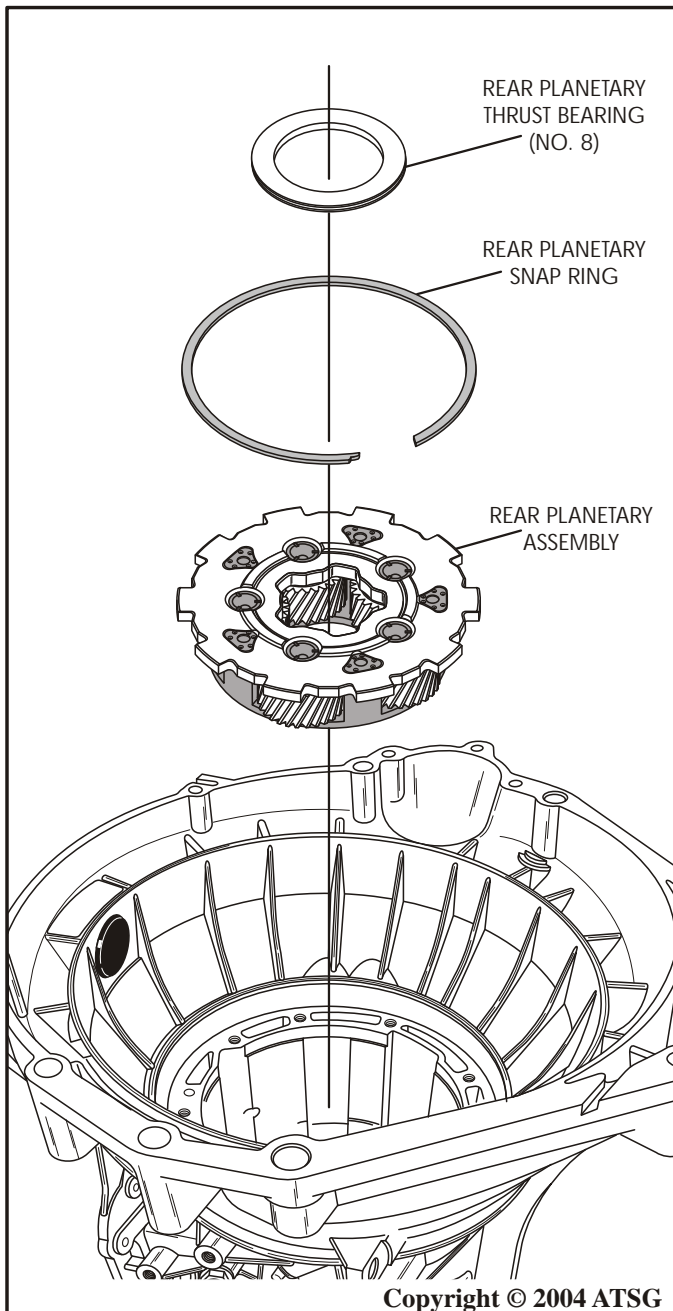

Figure 47

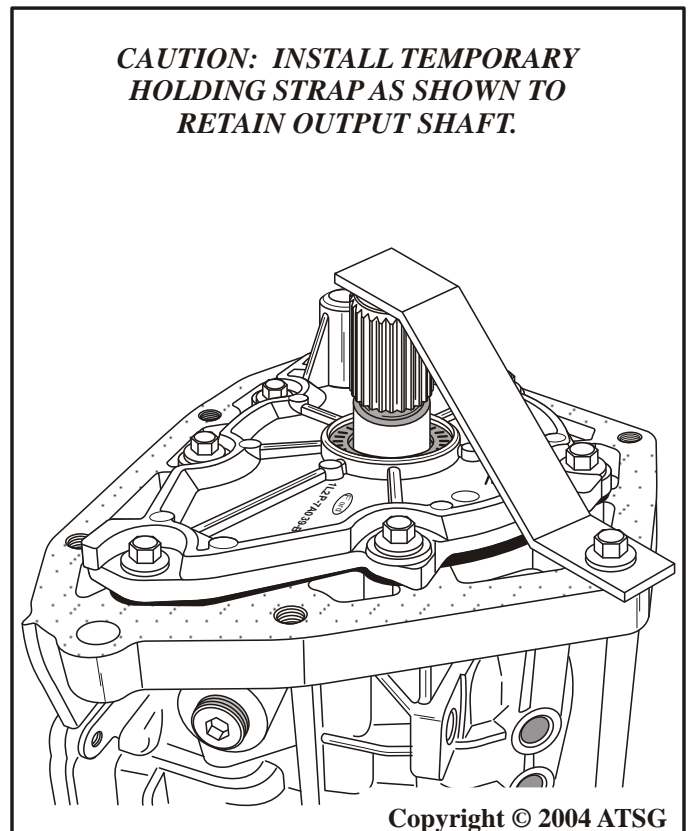

Figure 49

INTERNAL COMPONENTS (Cont'd)

55. Remove and tag for identification, the rear ring gear (No. 9) thrust bearing (See Figure 50).
56. Remove the rear planetary ring gear from the transmission, as shown in Figure 50.
57. Remove reverse drum and low sprag assembly by rotating and lifting drum out, as shown in Figure 51.
58. Remove and tag for I.D. the rear planetary gear thrust bearing (No. 10), as shown in Figure 51.
59. Remove the low/reverse band assembly from the case, as shown in Figure 51.
60. Rotate the transmission so that output shaft is facing up, as shown in Figure 52.

Continued on Page 37

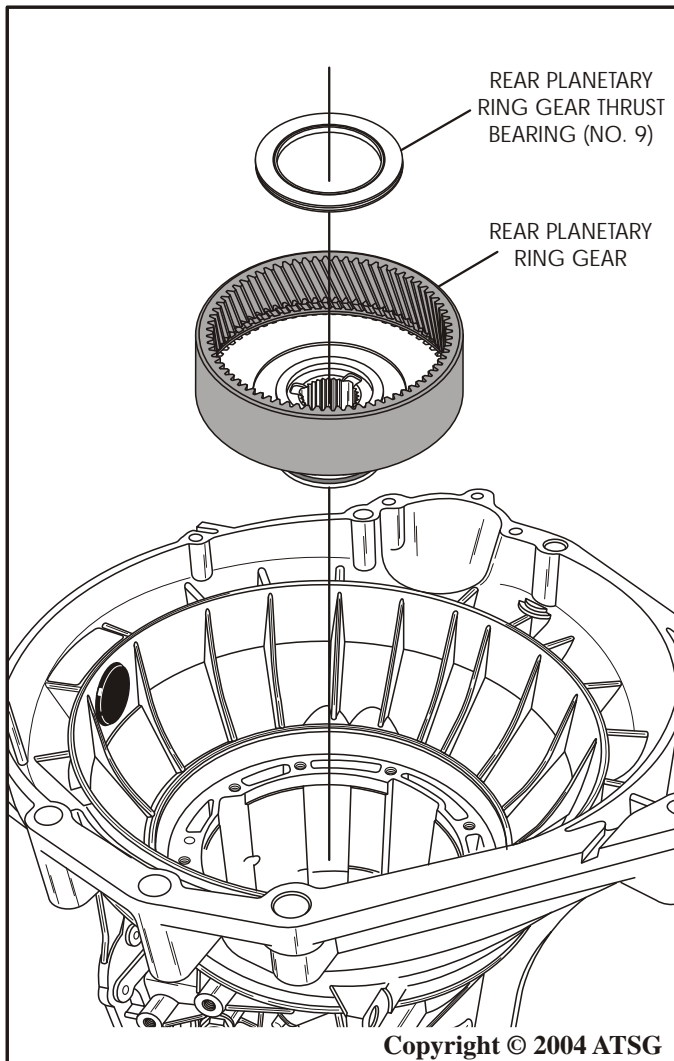

Figure 50

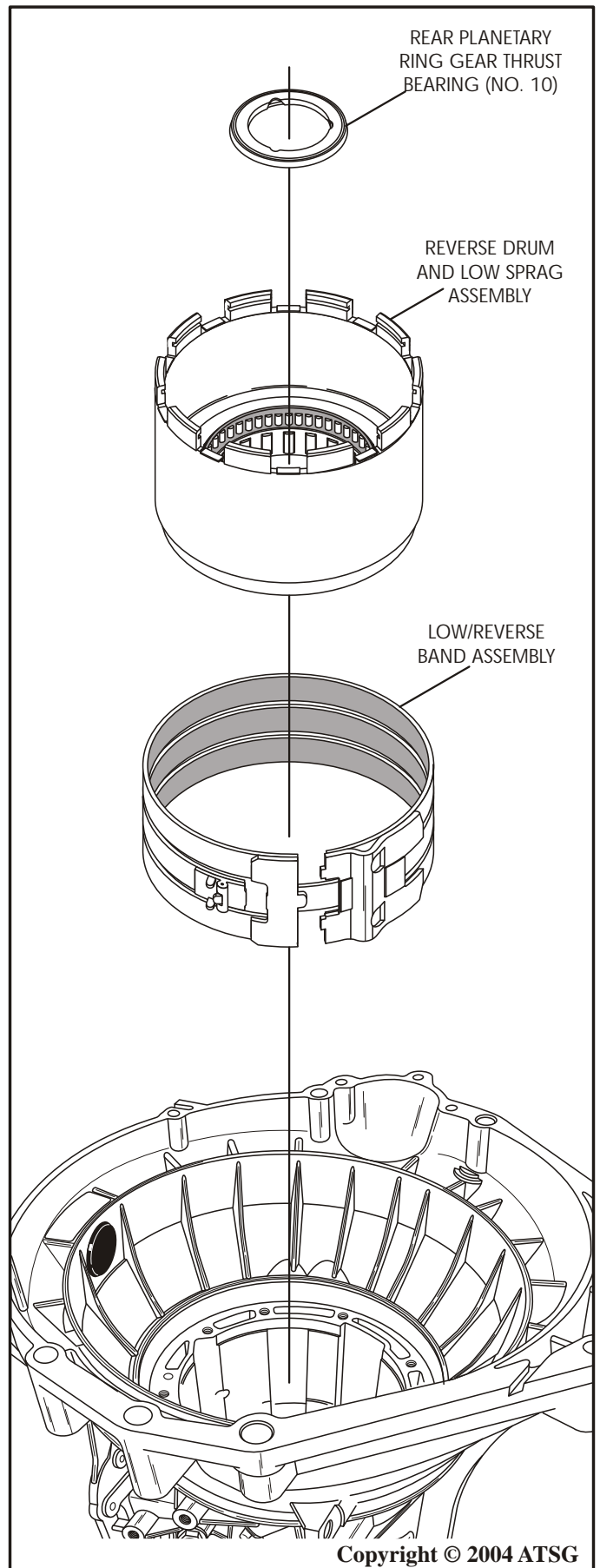

Figure 51

INTERNAL COMPONENTS (Cont'd)

61. Remove the temporary retaining bracket and the output shaft, as shown in Figure 52.
62. Remove the seven retaining bolts from 4WD adapter, as shown in Figure 53.
63. Remove the 4WD adapter housing, as shown in Figure 53, and set aside for the component rebuild section.

64. Remove and discard the 4WD adapter housing gasket, as shown in Figure 53.

Continued on Page 38

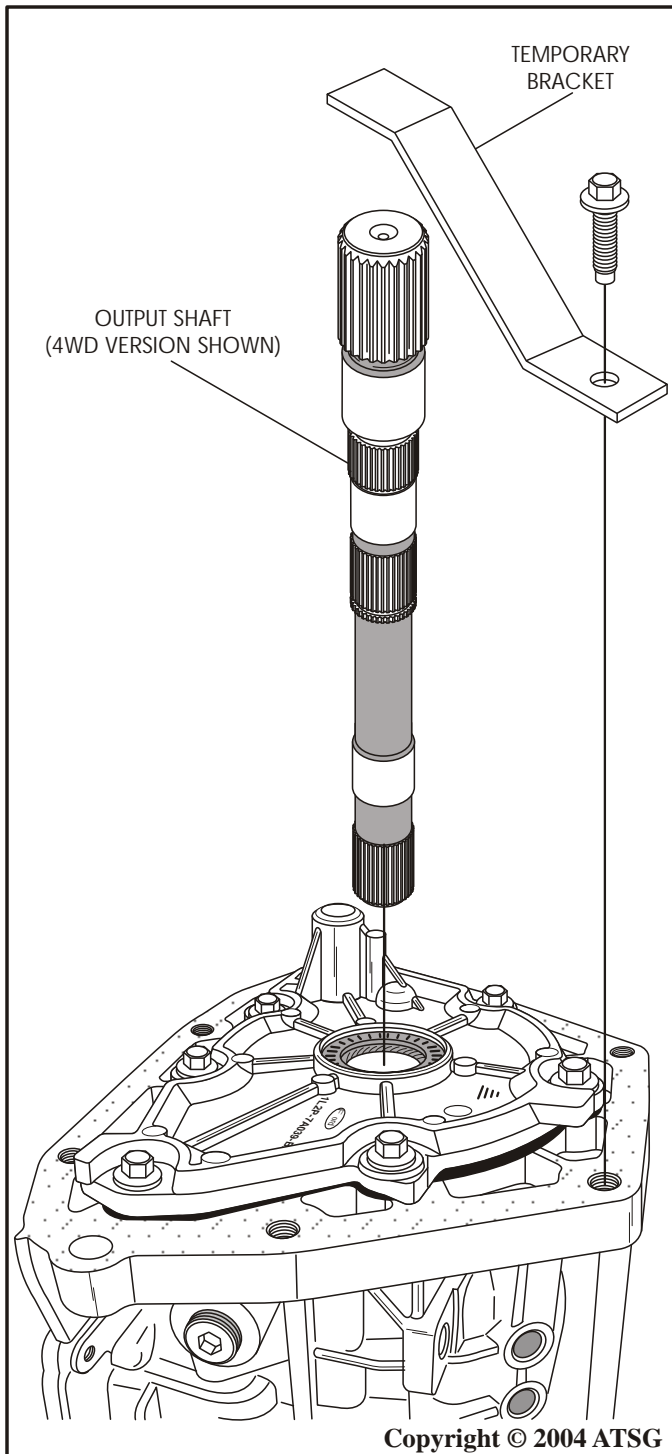

Figure 52

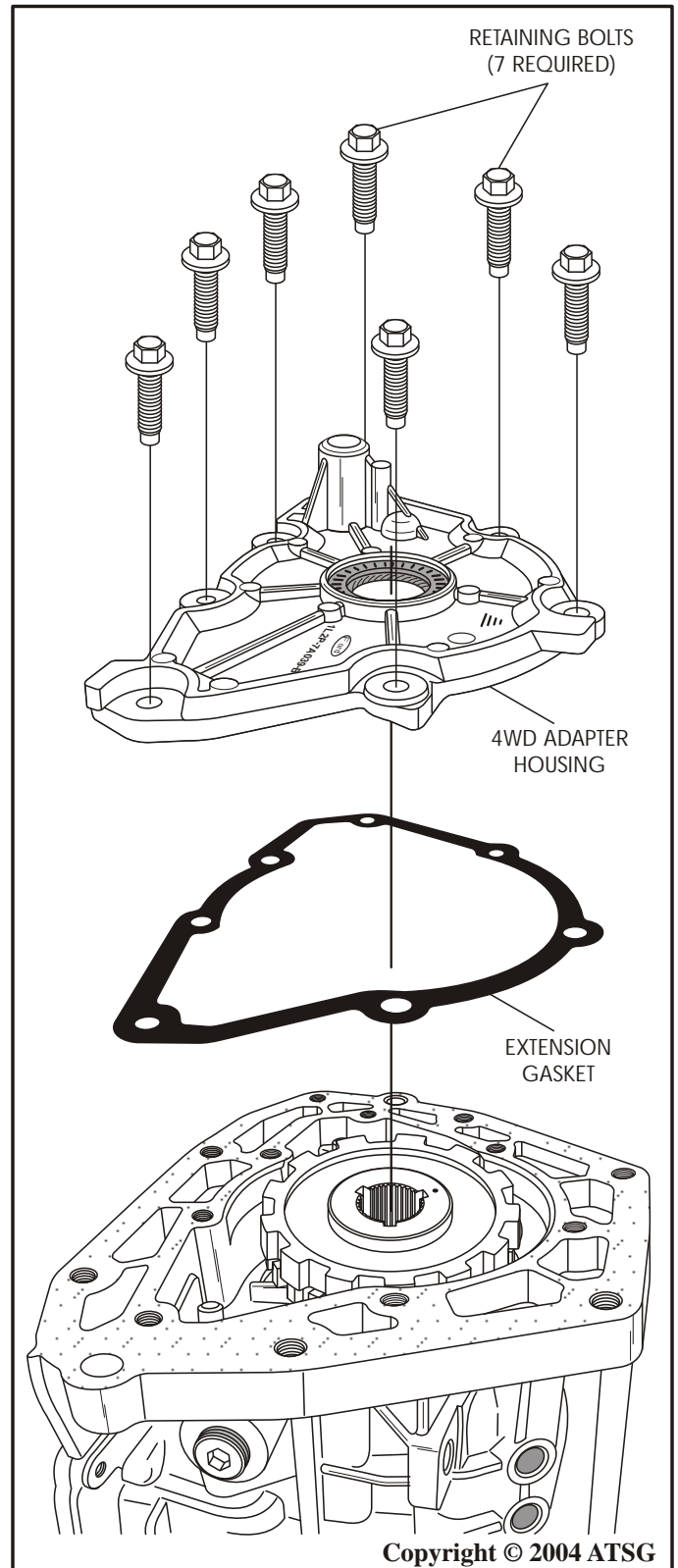

Figure 53

INTERNAL COMPONENTS (Cont'd)

65. Remove the park gear, as shown in Figure 54.
66. Remove and tag for I.D. the park gear thrust washer (No. 11), as shown in Figure 55.
67. This completes transmission disassembly.

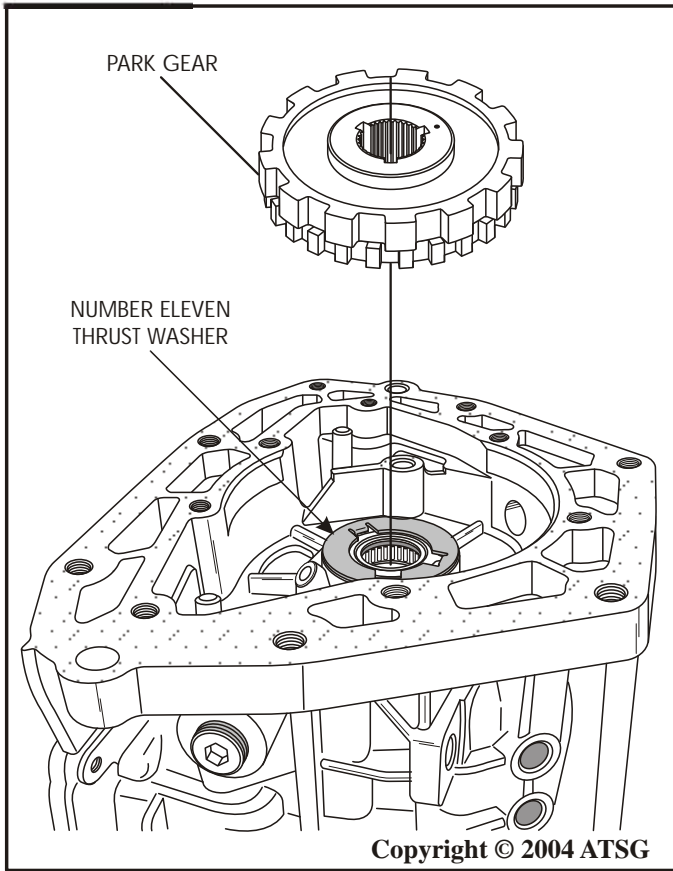

Figure 54

If replacement of the pump support assembly becomes necessary, ensure that replacement part has correct diameter recess for clearance of the different diameter O.D. sun gears, as shown below.

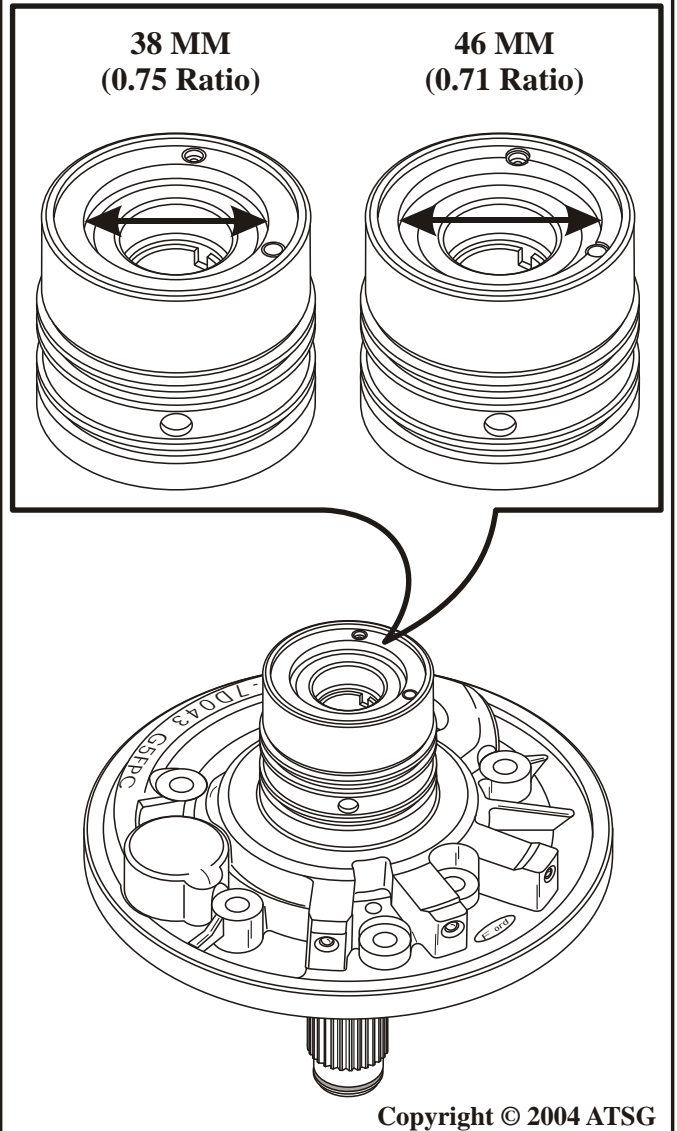

Figure 56

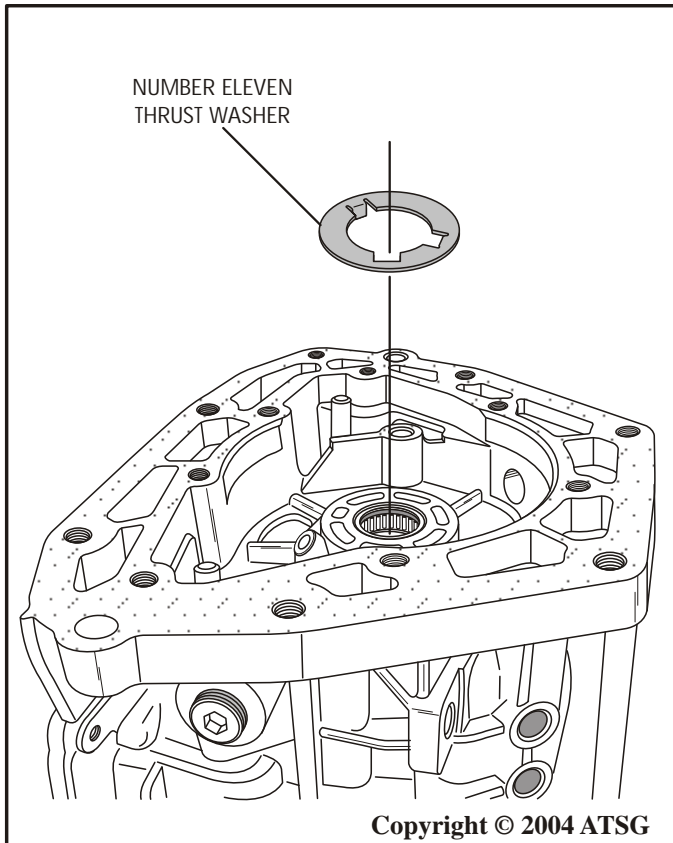

Figure 55

COMPONENT REBUILD SECTION

OIL PUMP ASSEMBLY

1. Disassemble the oil pump assembly using the illustrations in Figure 57 as a guide.
2. Remove and discard the converter seal and all sealing rings (See Figure 57).

3. Inspect all oil pump parts thoroughly for any wear and/or damage. **Note: If replacement of pump support is necessary, see Figure 56.**
4. Clean all oil pump and cover parts thoroughly and dry with compressed air

Continued on Page 40

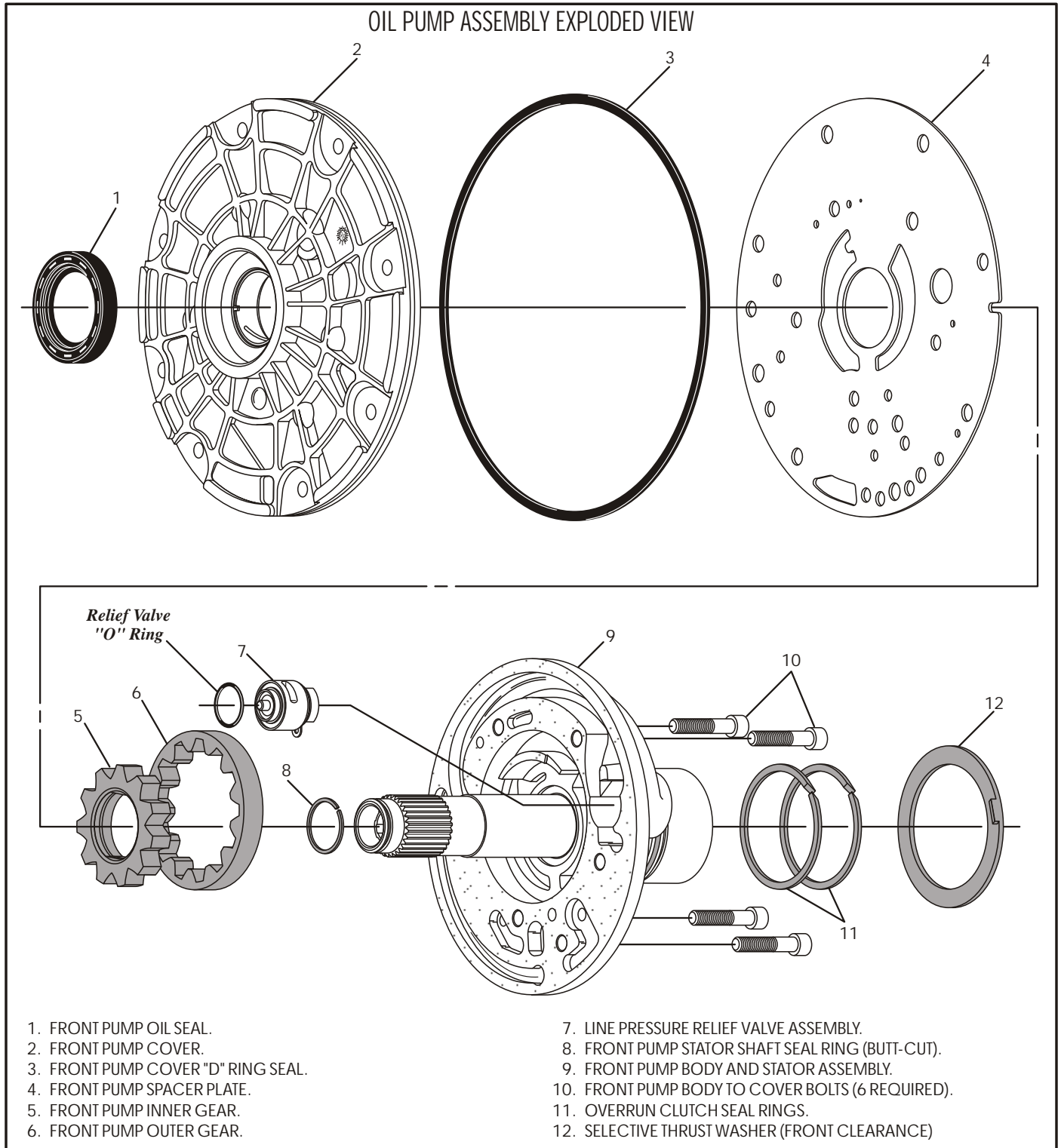

Figure 57

OIL PUMP ASSEMBLY (Cont'd)

5. Install selective thrust washer that came with the unit and retain with Trans-Jel®, as shown in Figure 58.
6. Install the two overrun clutch seal rings into their grooves and insure that the scarf cuts are assembled properly (See Figure 58).
7. Install a new "O" ring on the inside diameter of the inner pump gear and ensure that it is fully seated in the groove (See Figure 60). Lube with a small amount of Trans-Jel®.
8. Dip the pump gears into transmission fluid and install them with the "Dots" facing down, as shown in Figure 60.

Caution: The pump gears must be installed with the "Dots" facing down (See Figure 60).

9. Install a new "Solid" seal ring in the groove in the stator shaft, as shown in Figure 60.
10. Install the line pressure relief valve into the cavity in the pump, as shown in Figure 60.

Caution: See Note In Figure 59.

CAUTION: The Pump Relief Valve Assembly "Must" Have The "O" Ring In Place As Shown Below

"O" RING IN PLACE ON RELIEF VALVE

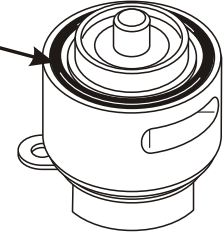

Copyright © 2004 ATSG

Figure 59

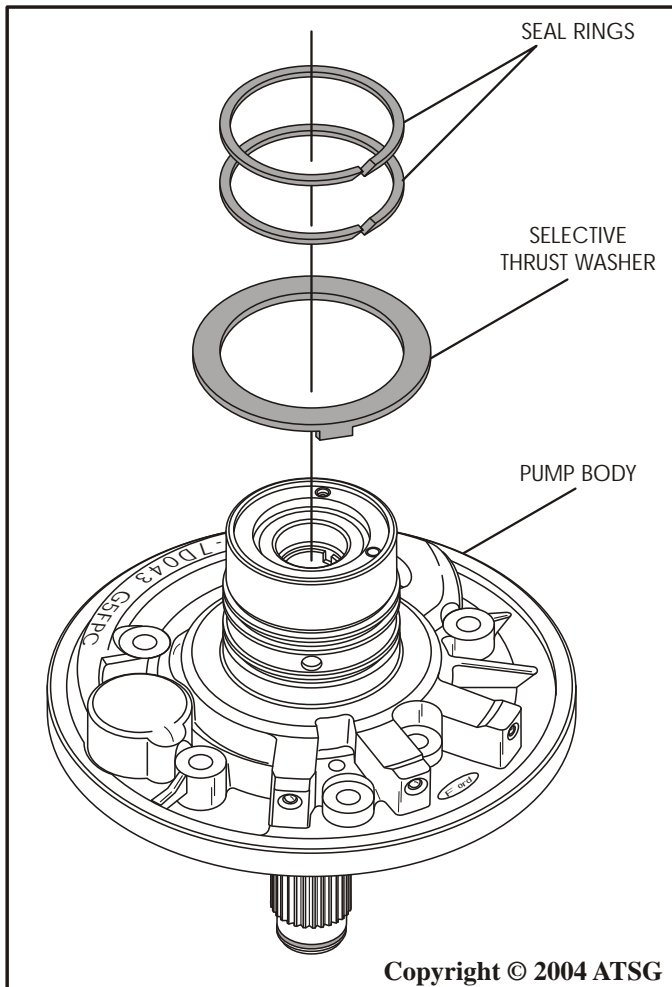

Copyright © 2004 ATSG

Figure 58

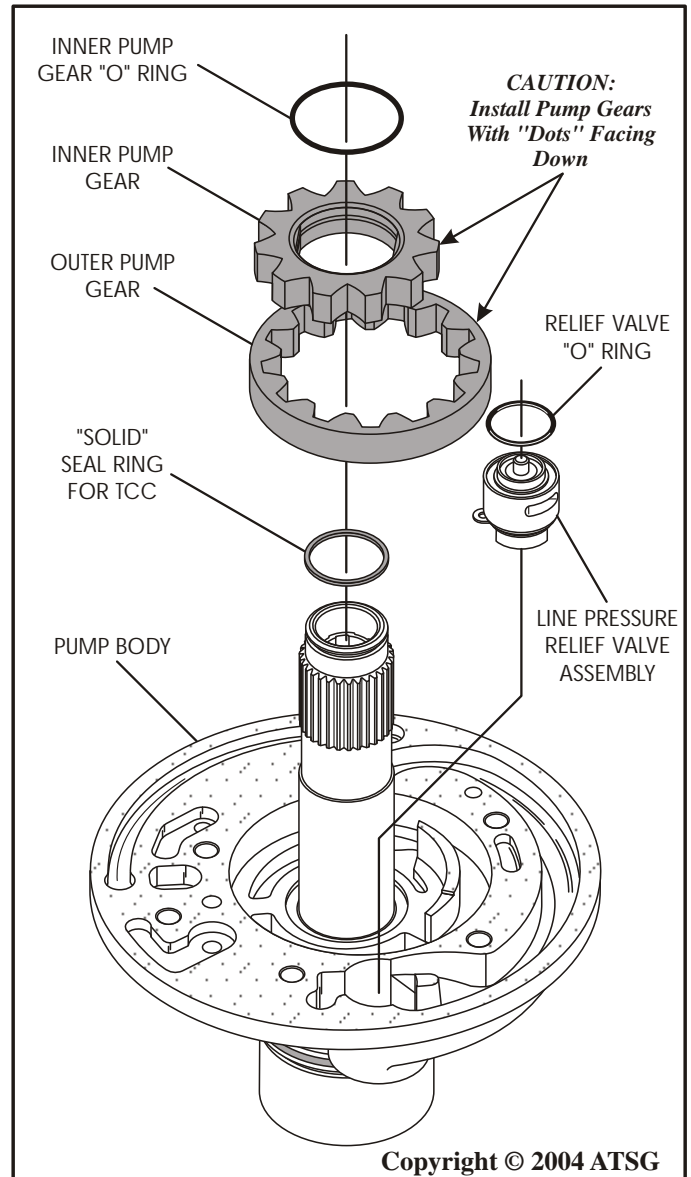

Copyright © 2004 ATSG

Figure 60

OIL PUMP ASSEMBLY (Cont'd)

11. Install a new converter seal into the oil pump cover using the proper seal driver, as shown in Figure 61.
12. Install a new "D" ring seal into outer groove of the oil pump cover, as shown in Figure 61.
13. Lubricate both seals and bushing with a small amount of Trans-Jel®.
14. Place pump body and stator shaft assembly on bench with shaft facing up (See Figure 62).
Note: Ensure that the "O" ring seal is still in place on the relief valve (See Figure 62).
15. Install oil pump spacer plate and pump cover onto pump body, as shown in Figure 62.

Continued on Page 42

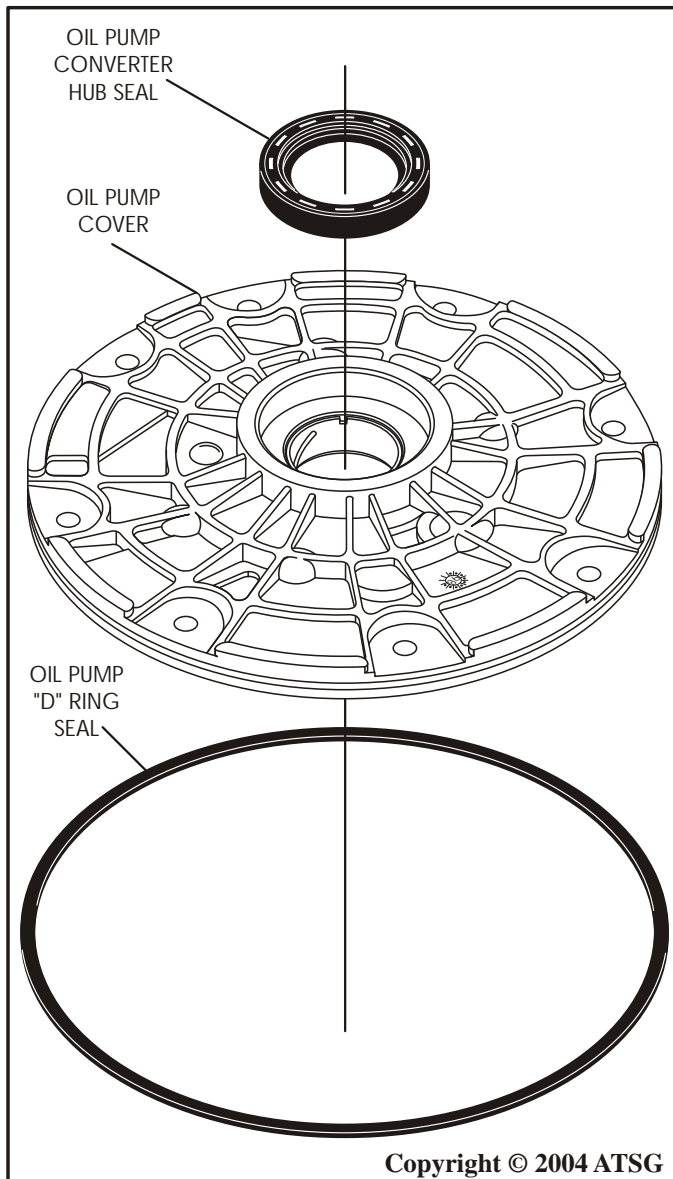

Figure 61

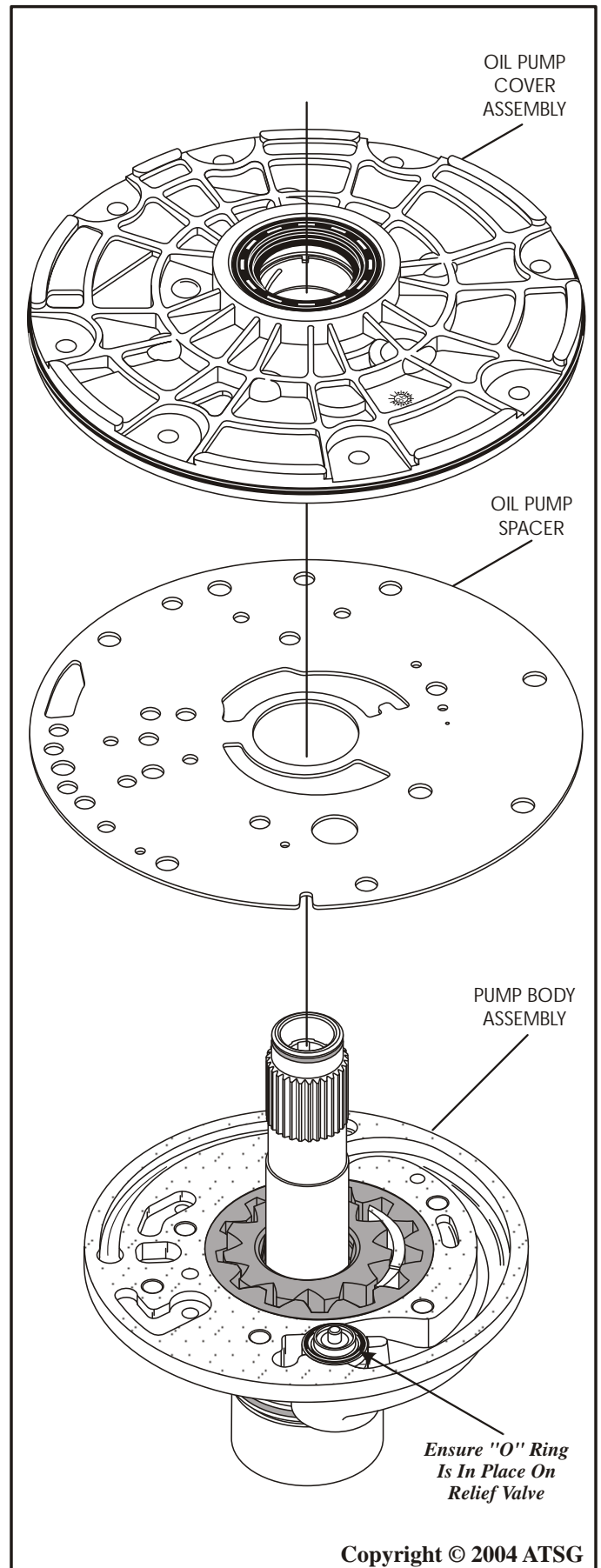

Figure 62

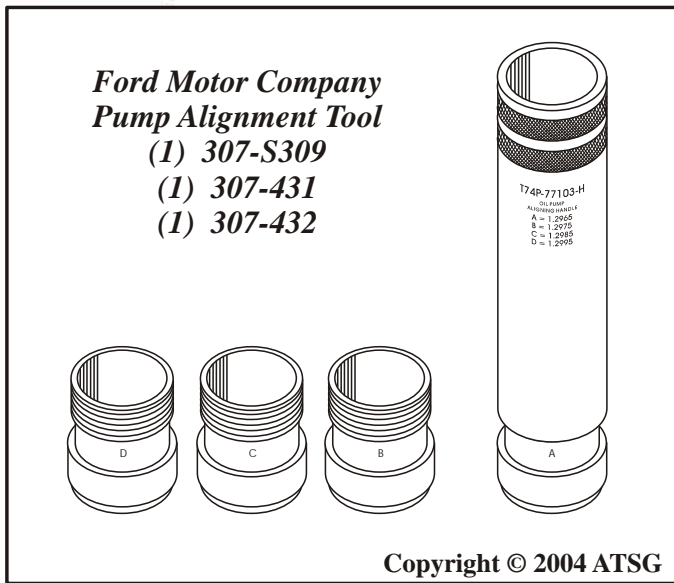

Figure 63

OIL PUMP ASSEMBLY (Cont'd)

16. Install the appropriate size sleeve into handle of Ford Motor Co. Pump Alignment Tools, shown in Figure 63, and install into pump.
17. Turn the assembly over and install the six bolts that retain the body to the cover, as shown in Figure 64.
18. With the **alignment tool in place**, torque all six bolts in a star pattern to 18 ft.lb. as shown in Figure 65.
19. Remove the alignment tool and ensure that the pump gears will turn after they are torqued, as shown in Figure 65.
20. Set the completed pump assembly aside for the final assembly process.

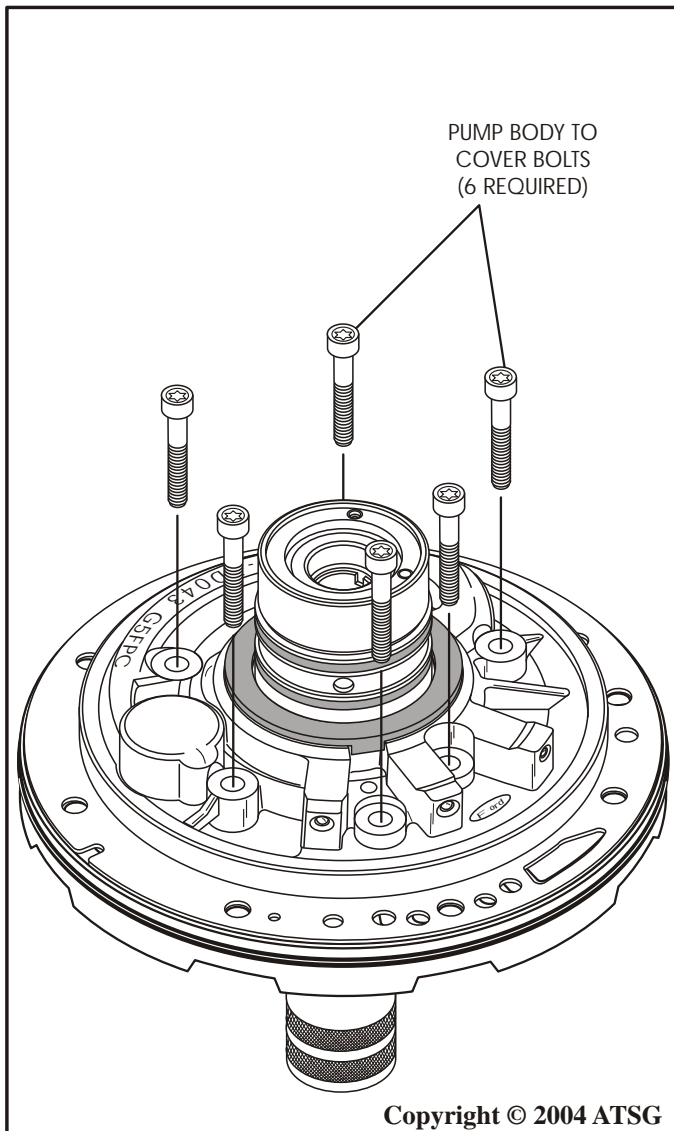

Figure 64

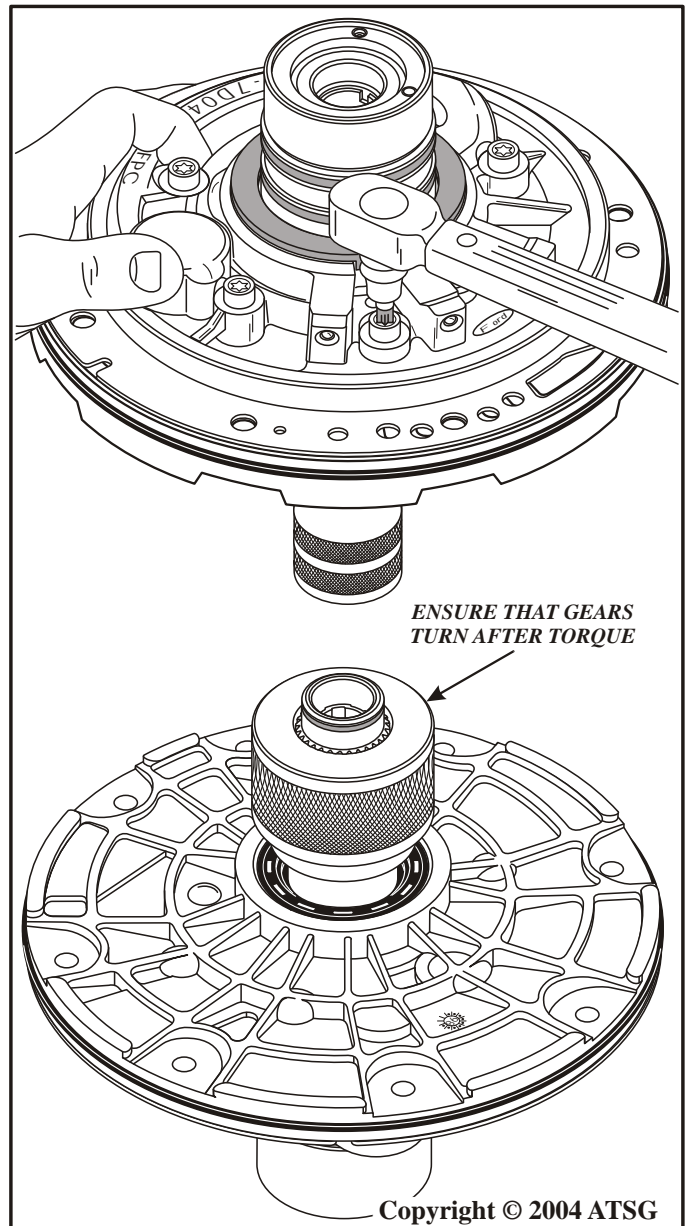

Figure 65

COAST CLUTCH ASSEMBLY

1. Disassemble the coast clutch assembly using the illustrations in Figure 66 as a guide.
2. Remove and discard the coast clutch lip seals, as shown in Figure 66.
3. Inspect all coast clutch parts thoroughly for any wear and/or damage.
4. Clean all coast clutch parts thoroughly and dry with compressed air.

Continued on Page 44

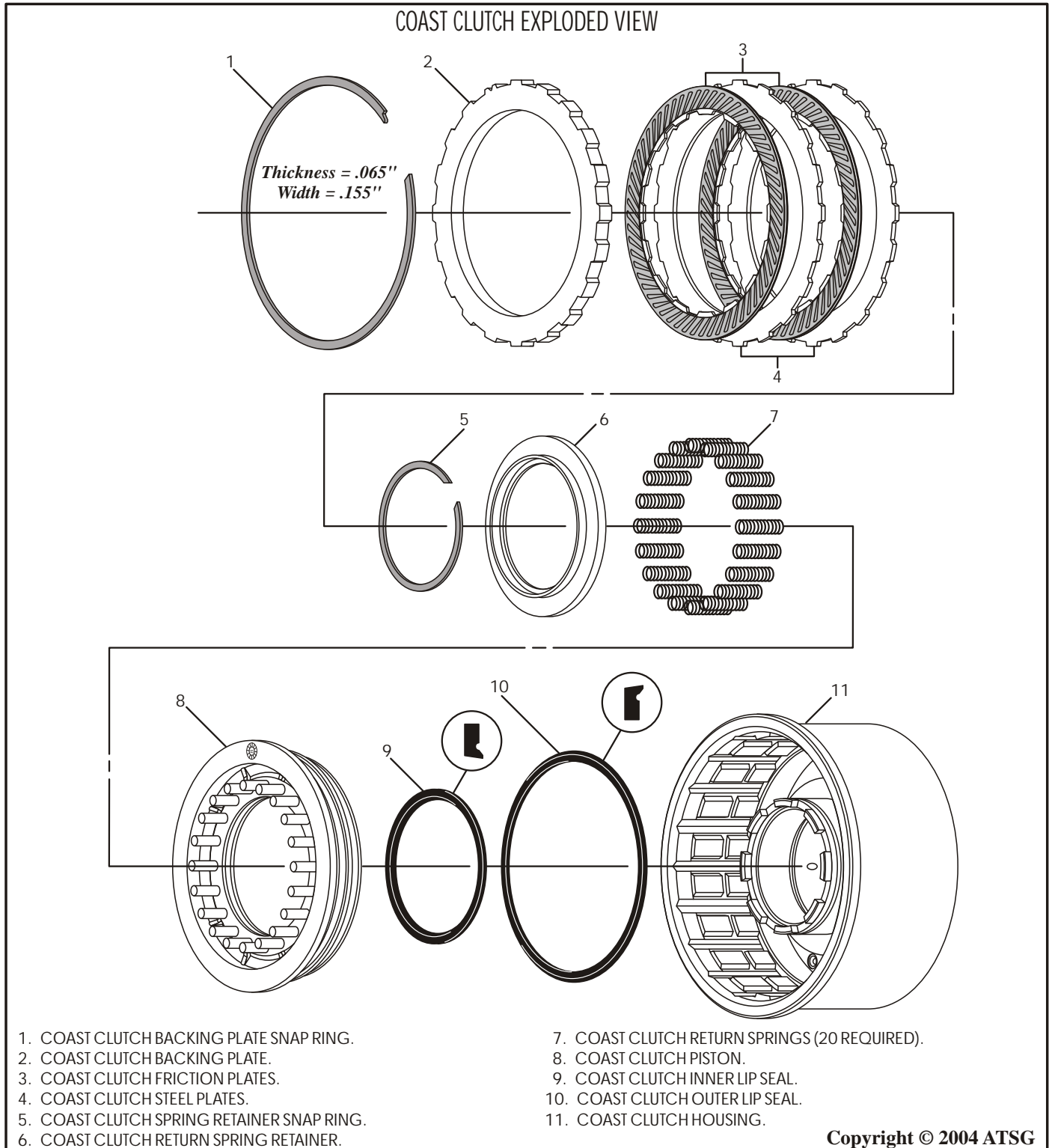

Figure 66

COAST CLUTCH ASSEMBLY (Cont'd)

5. Install a new inner lip seal into the groove in the coast clutch piston, with the lip facing down, as shown in Figure 67.
6. Install a new outer lip seal into the groove in the coast clutch piston, with the lip facing down, as shown in Figure 67.
7. Lubricate both inner and outer lip seals with a small amount of Trans-Jel®.
8. Lubricate both the inner and outer seal surfaces in coast clutch housing with a small amount of Trans-Jel®.
9. Install the completed coast clutch piston into the overrun clutch housing with twisting motion, as shown in Figure 68.

Continued on Page 45

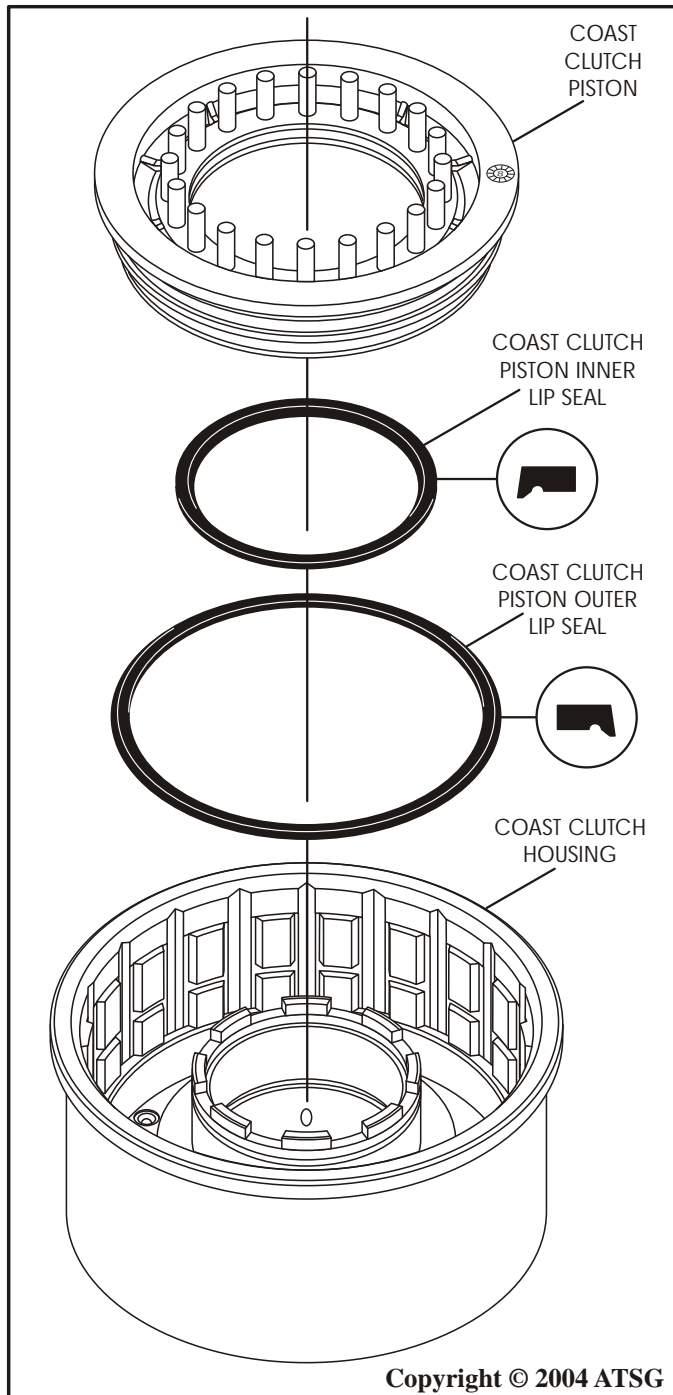

Figure 67

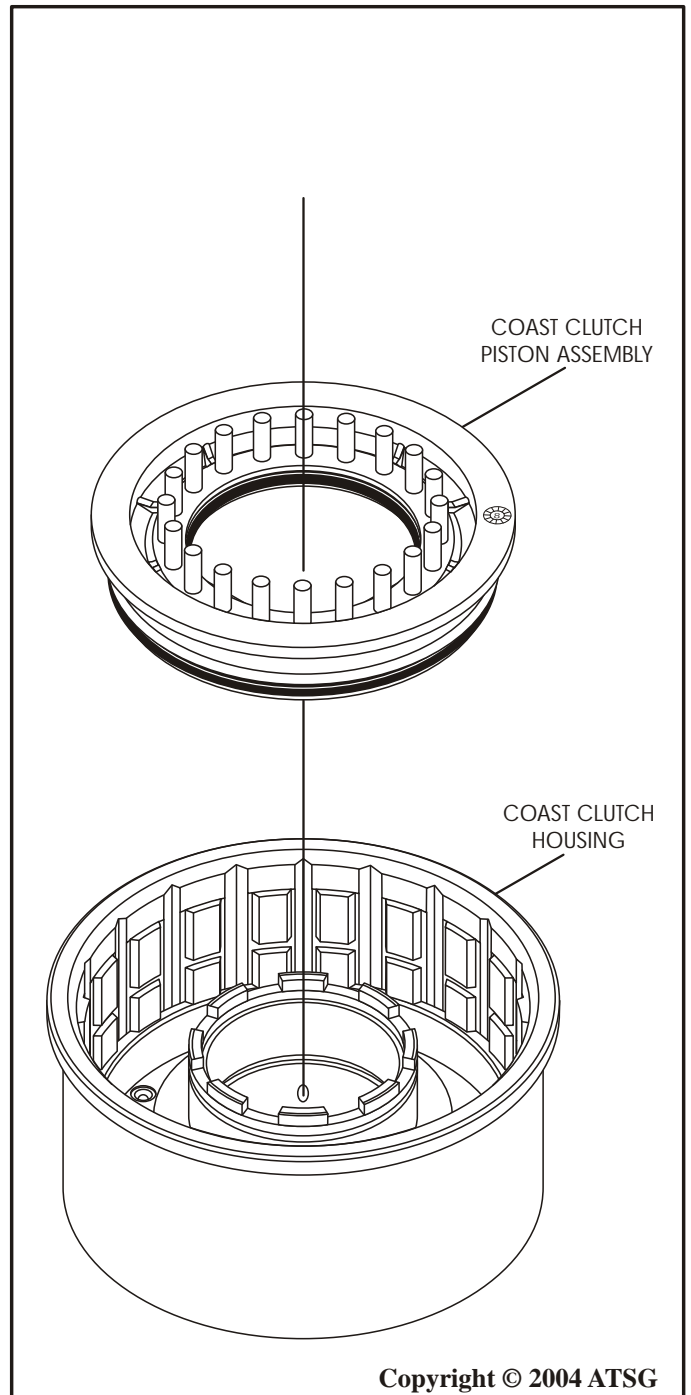

Figure 68

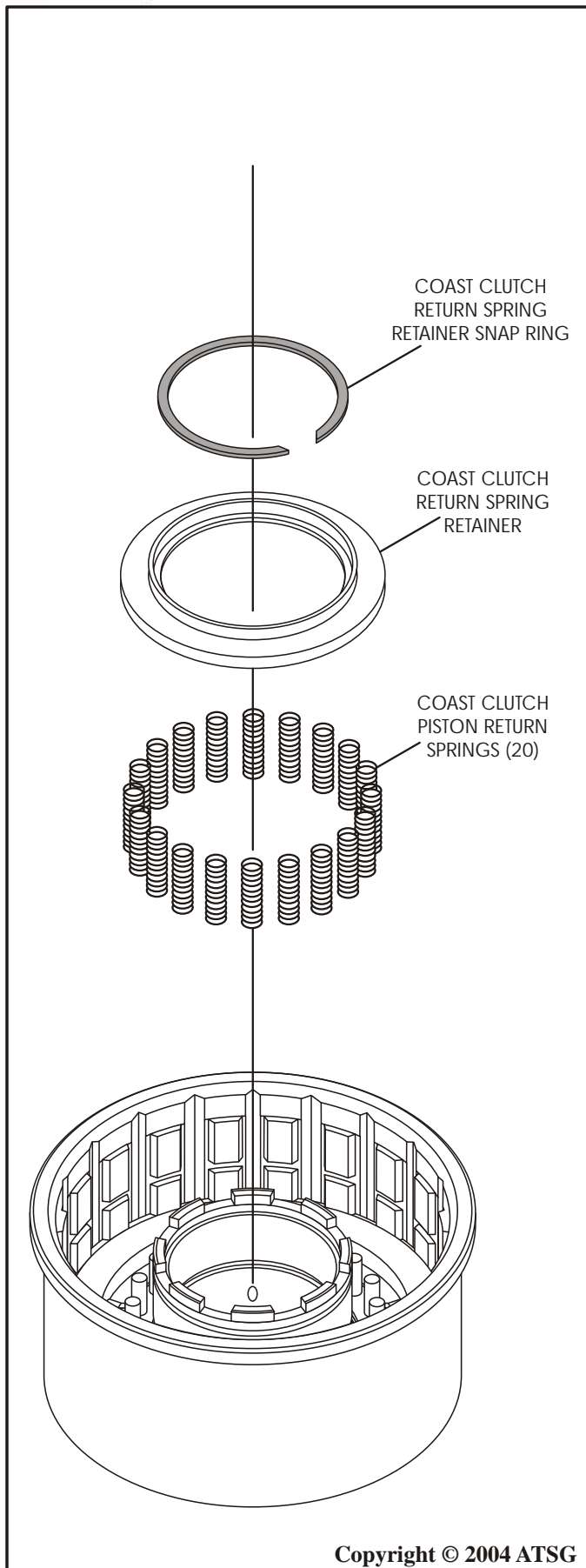

Figure 69

COAST CLUTCH ASSEMBLY (Cont'd)

10. Install the coast clutch piston return springs on the coast clutch piston, as shown in Figure 69.
11. Install the coast clutch return spring retainer on top of return springs, as shown in Figure 69.
12. Carefully compress the retainer and the return springs and install the retaining snap ring, as shown in Figure 69.
13. Remove the spring compressor and ensure that everything is fully seated.
14. Install the friction and steel coast clutch plates into the coast clutch drum, beginning with a steel plate and alternating with a friction plate, until you have installed two of each, as shown in Figure 70.

CAUTION: *Coast Clutch friction plates are directional and must be installed with the grooves facing clockwise, as shown in Figures 70 and 71. Friction plates should be soaked in Mercon® V for at least 30 minutes before installation.*

15. Install the coast clutch backing plate, as shown in Figure 70.
16. Install the coast clutch backing plate snap ring, as shown in Figure 70 and ensure that it is fully seated in the groove (See Figure 70).
17. Install dial indicator on top of backing plate, as shown in Figure 72, and check the coast clutch clearance. Should be 1.3-2.0mm (.051"-.079"), as shown in Figure 72.
18. Change the selective backing plate snap ring as necessary, using the chart in Figure 72, to get the proper clutch clearance.
19. Set the completed coast clutch housing aside for the final assembly process.

Copyright © 2004 ATSG

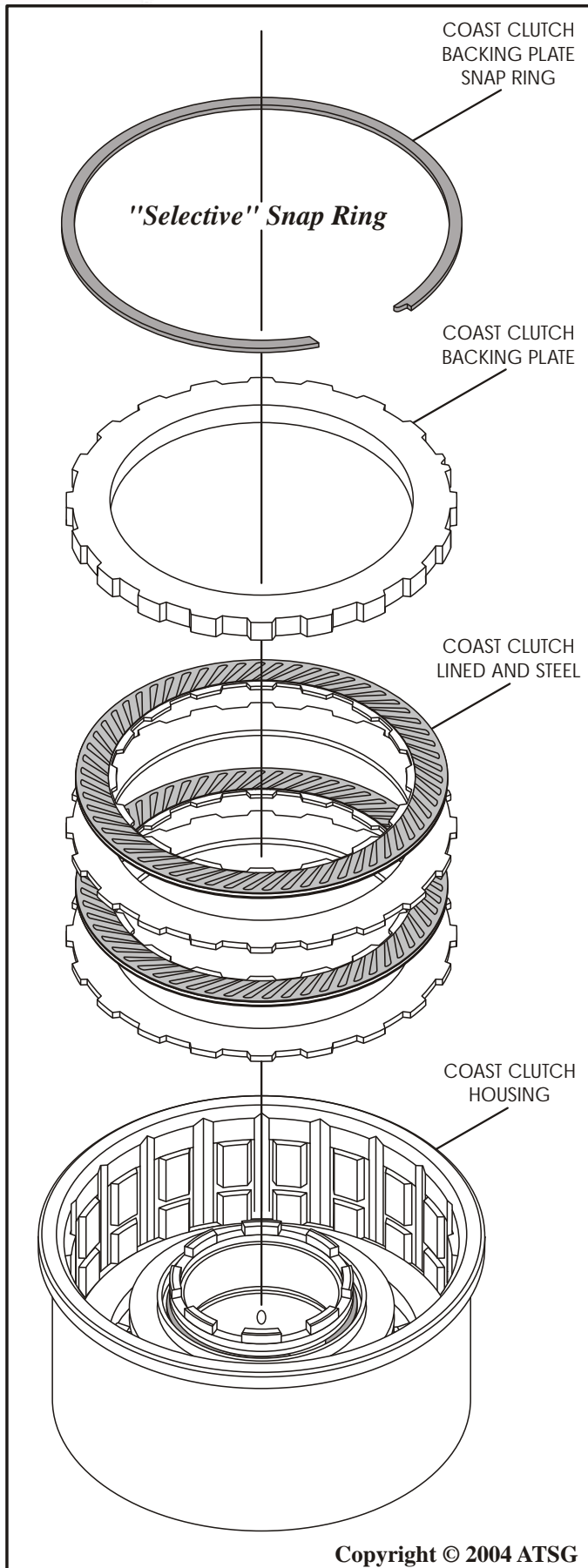

Figure 70

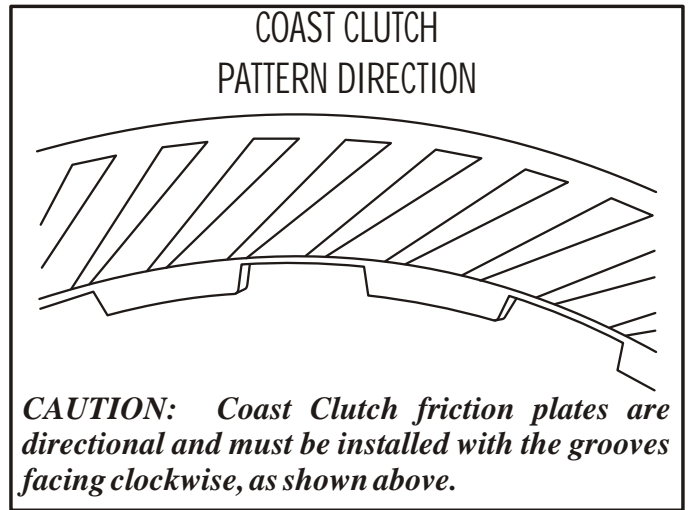
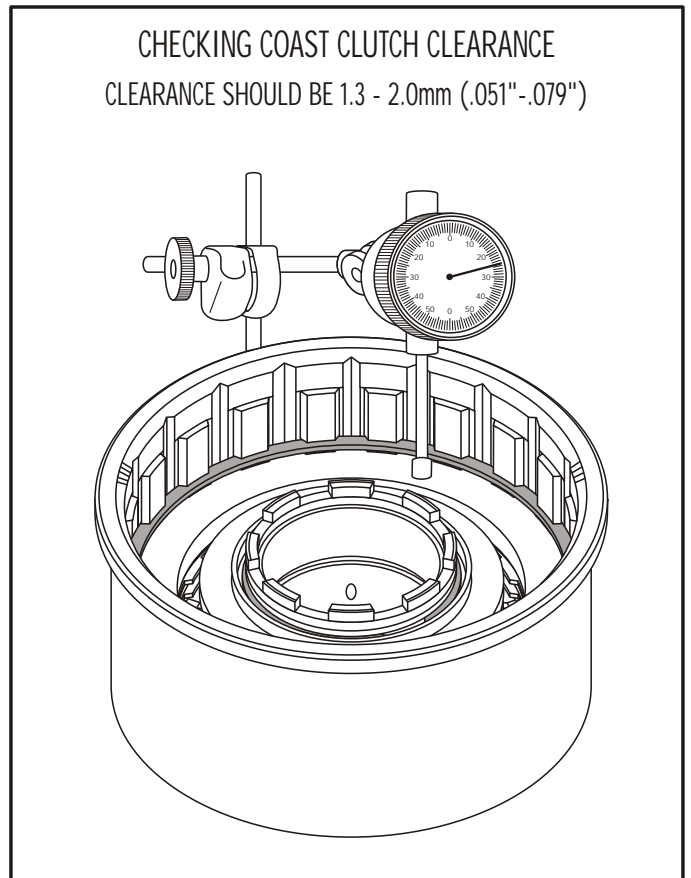

Figure 71



Part Number	Thickness	
	mm	in
E860126-S	1.37	.054"
E860127-S	1.73	.068"
E860128-S	2.08	.082"
E860129-S	2.44	.096"

Copyright © 2004 ATSG

Figure 72

OVERDRIVE CARRIER AND SPRAG ASSEMBLY

1. Disassemble the overdrive carrier from center shaft using Figure 73 as a guide.
2. Inspect all of the overdrive carrier parts shown in Figure 73 for any wear and/or damage.
3. Clean all overdrive carrier parts thoroughly and dry with compressed air.
4. Install the overdrive sprag assembly into the overdrive center shaft, in the direction shown in Figure 74, until fully seated.
5. Install thrust bearing onto overdrive carrier, as shown in Figure 75, and retain with a small amount of Trans-Jel®.
6. Install completed overdrive center shaft onto the overdrive carrier by rotating shaft counter clockwise as you install (See Figure 76).
7. Verify proper overdrive sprag rotation, using Figure 76, and then set the overdrive planetary carrier assembly aside for final assembly.

Continued on Page 48

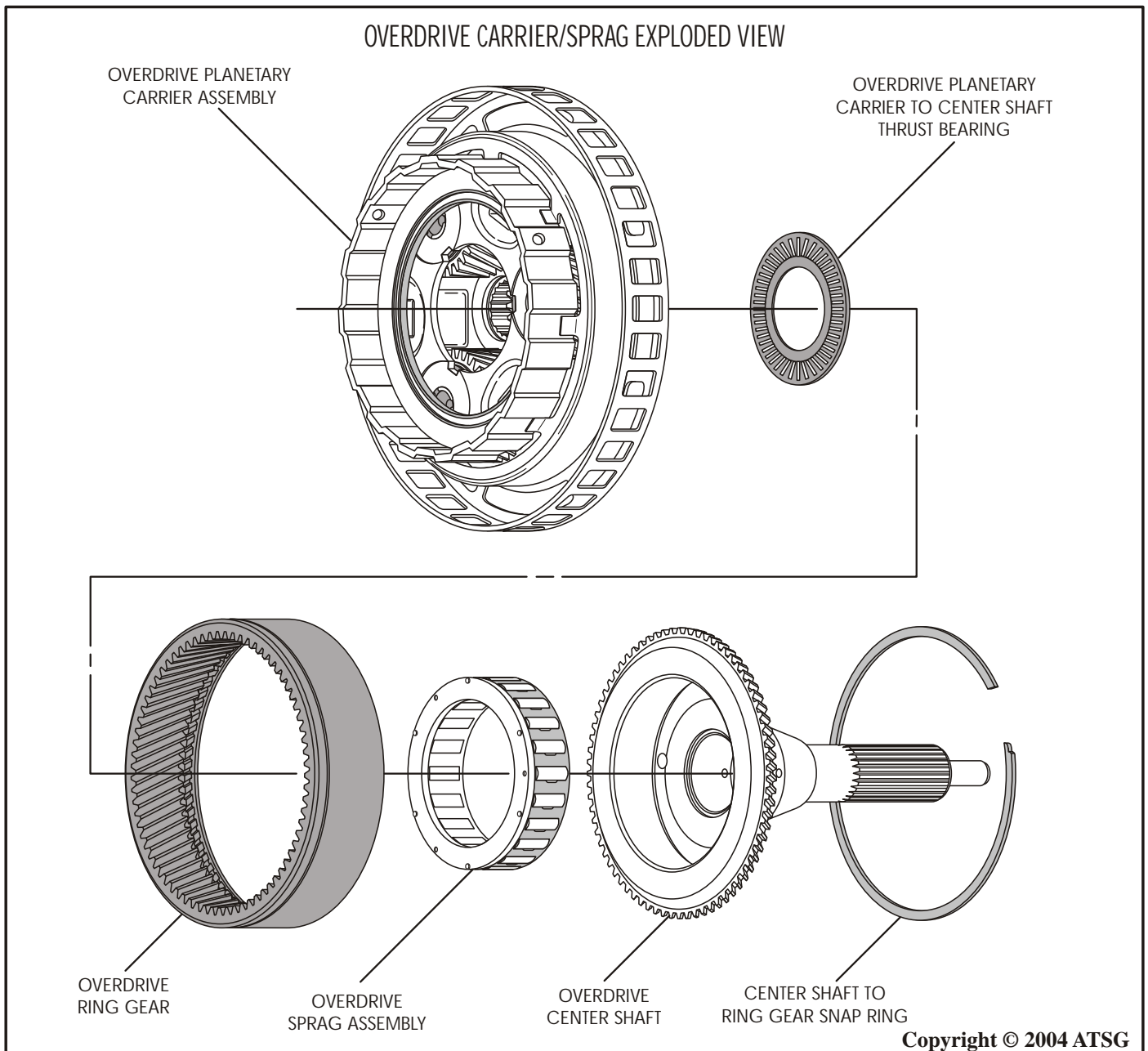

Figure 73

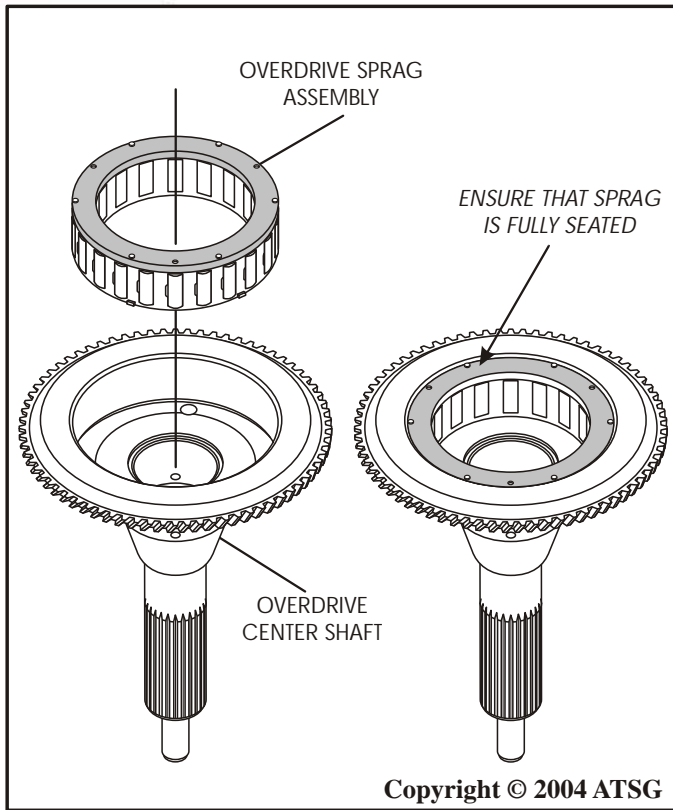
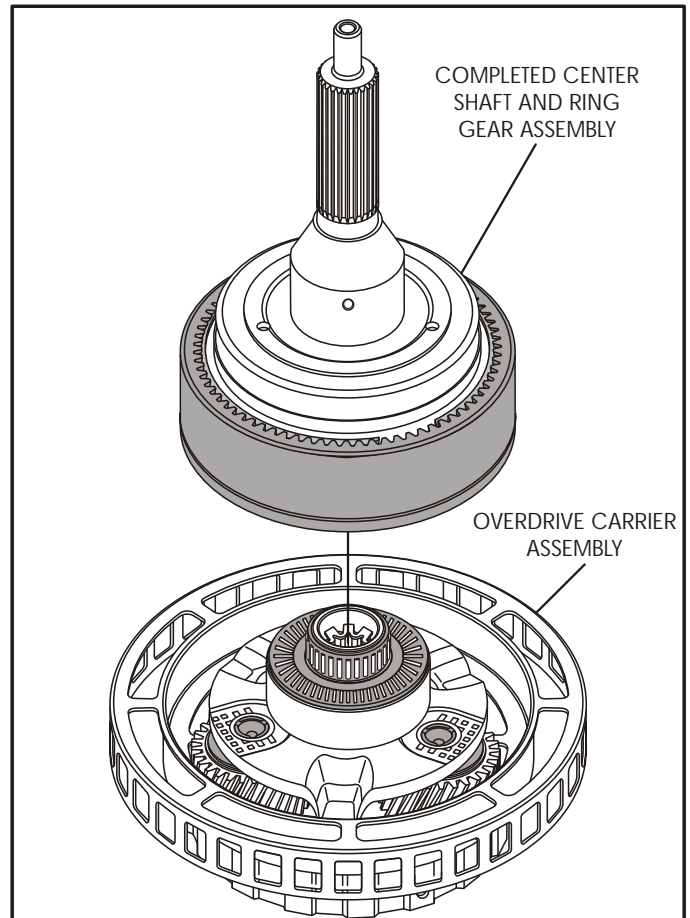
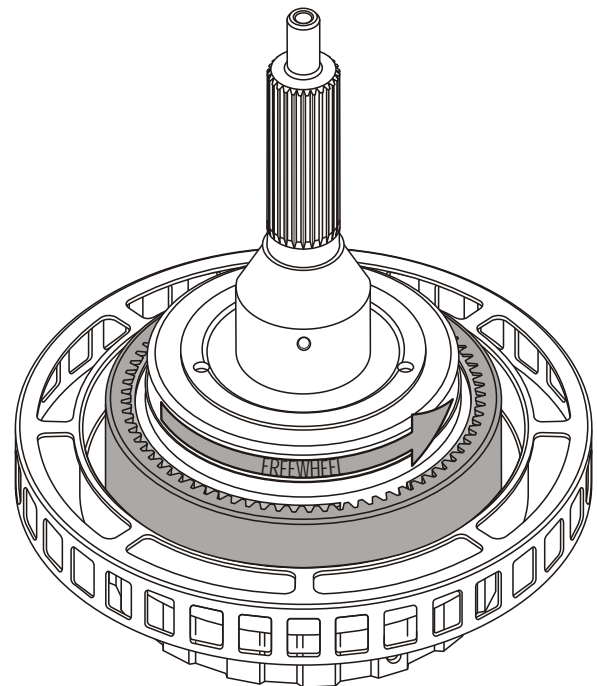

Figure 74



VIEWS FROM CENTER SHAFT SIDE
*Center Shaft Must Freewheel
 "Counter-Clockwise" While Holding
 The Overdrive Carrier*



Copyright © 2004 ATSG

Figure 76

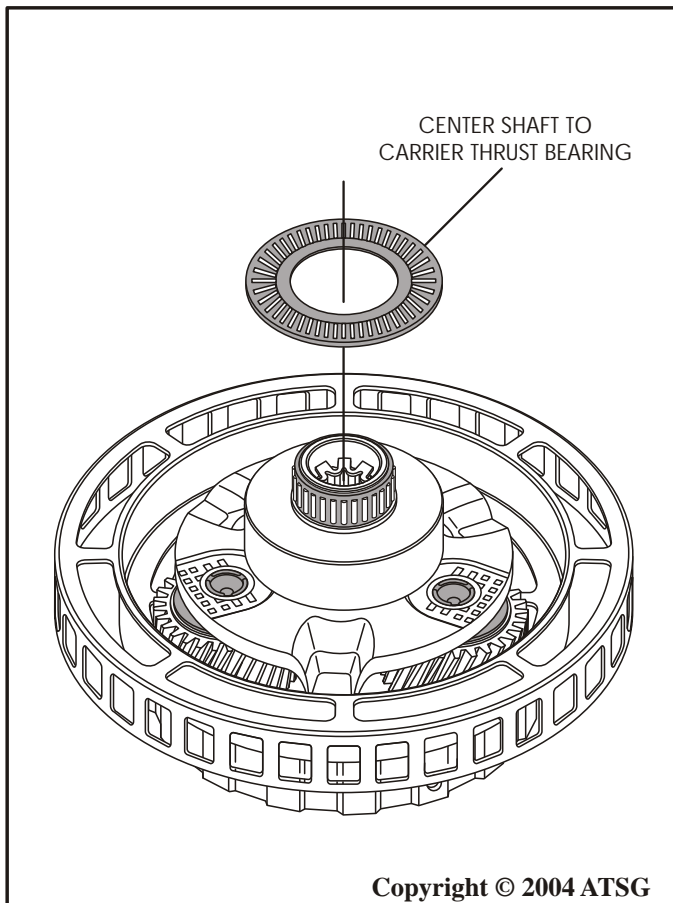

Copyright © 2004 ATSG

Figure 75

DIRECT CLUTCH ASSEMBLY

1. Disassemble the direct clutch assembly using the illustrations in Figure 77 as a guide.
2. Remove and discard the direct clutch lip seals, as shown in Figure 77.
3. Inspect all direct clutch parts thoroughly for any wear and/or damage.
4. Clean all direct clutch parts thoroughly and dry with compressed air.

Continued on Page 50

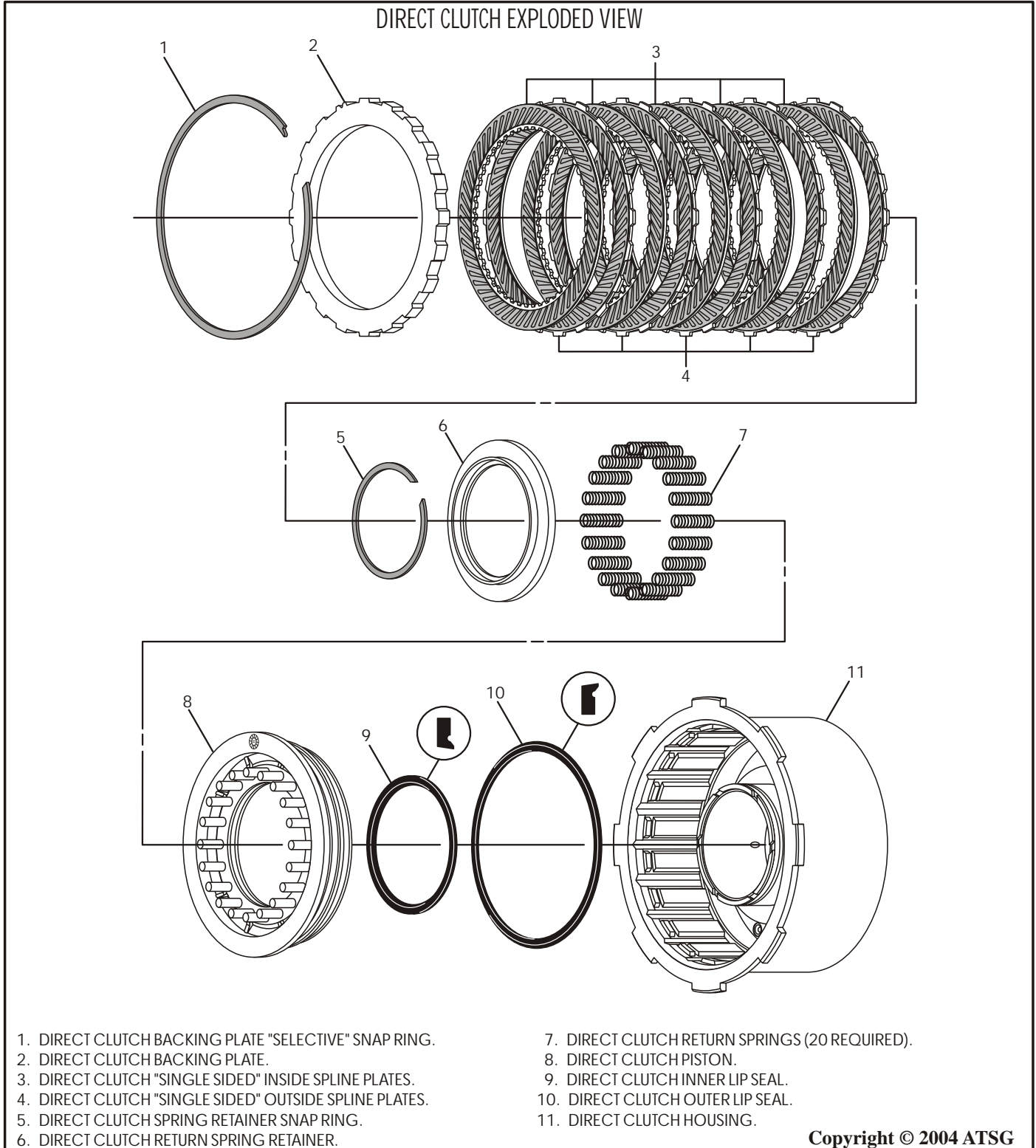

Copyright © 2004 ATSG

Figure 77

DIRECT CLUTCH ASSEMBLY (Cont'd)

5. Install a new inner lip seal into the groove in the direct clutch piston, with the lip facing down, as shown in Figure 78.
6. Install a new outer lip seal into the groove in the direct clutch piston, with the lip facing down, as shown in Figure 78.
7. Lubricate both inner and outer lip seals with a small amount of Trans-Jel®.
8. Lubricate both the inner and outer seal surfaces in direct clutch housing with a small amount of Trans-Jel®.
9. Install the completed direct clutch piston into the direct clutch housing with twisting motion, as shown in Figure 80.
10. Install the direct clutch piston return springs on the direct clutch piston, as shown in Figure 81.
11. Install the direct clutch return spring retainer on top of return springs, as shown in Figure 81.
12. Carefully compress the retainer and the return springs and install the retaining snap ring, as shown in Figure 81.
13. Remove the spring compressor and ensure that everything is fully seated.

CAUTION: *Direct Clutch friction plates are directional and must be installed with the internal tooth plate grooves facing clockwise, and the external tooth plates grooves facing counterclockwise, as shown in Figure 79.*

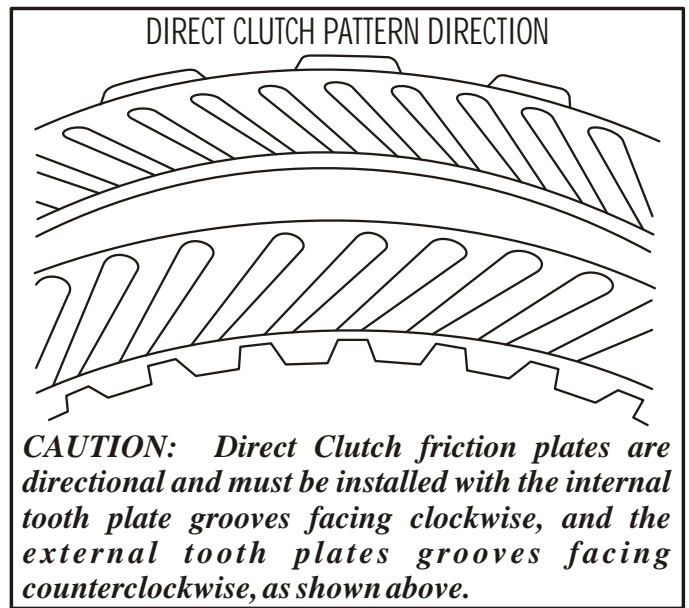

Figure 79

14. Install the direct clutches beginning with an outside spline plate and alternating with inside spline plates, until you have installed 5 of each, as shown in Figure 82.

Caution: *Friction plates should be soaked in Mercon® V, 30 minutes before installing.*

Continued on Page 51

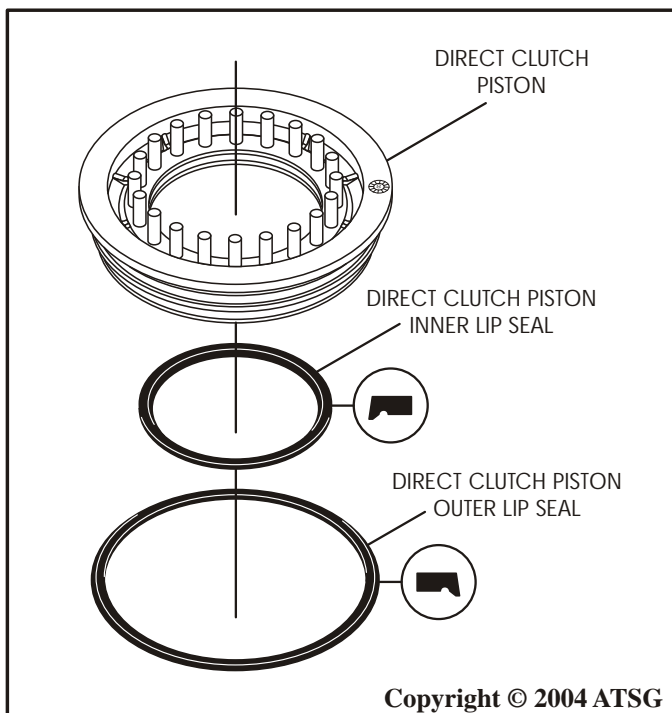

Figure 78

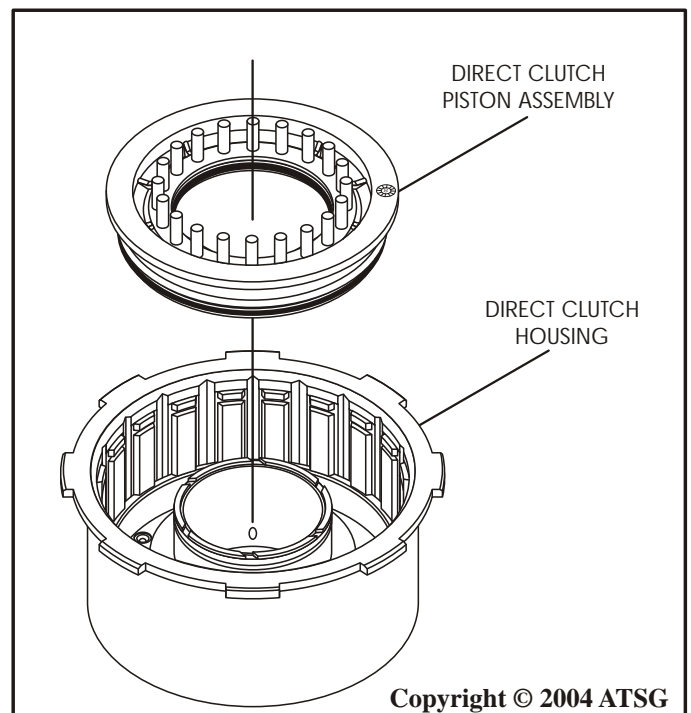

Figure 80

DIRECT CLUTCH ASSEMBLY (Cont'd)

15. Install the direct clutch backing plate, as shown in Figure 82.
16. Install the direct clutch backing plate snap ring, as shown in Figure 82 and ensure that it is fully seated in the groove (See Figure 82).
17. Install dial indicator on top of backing plate, as shown in Figure 83, and check the direct clutch clearance. Should be 1.3-2.0mm (.051"-.079"), as shown in Figure 83.
18. Change the selective backing plate snap ring as necessary, using the chart in Figure 83, to get the proper direct clutch clearance.
19. Set the completed direct clutch housing aside for the final assembly process.

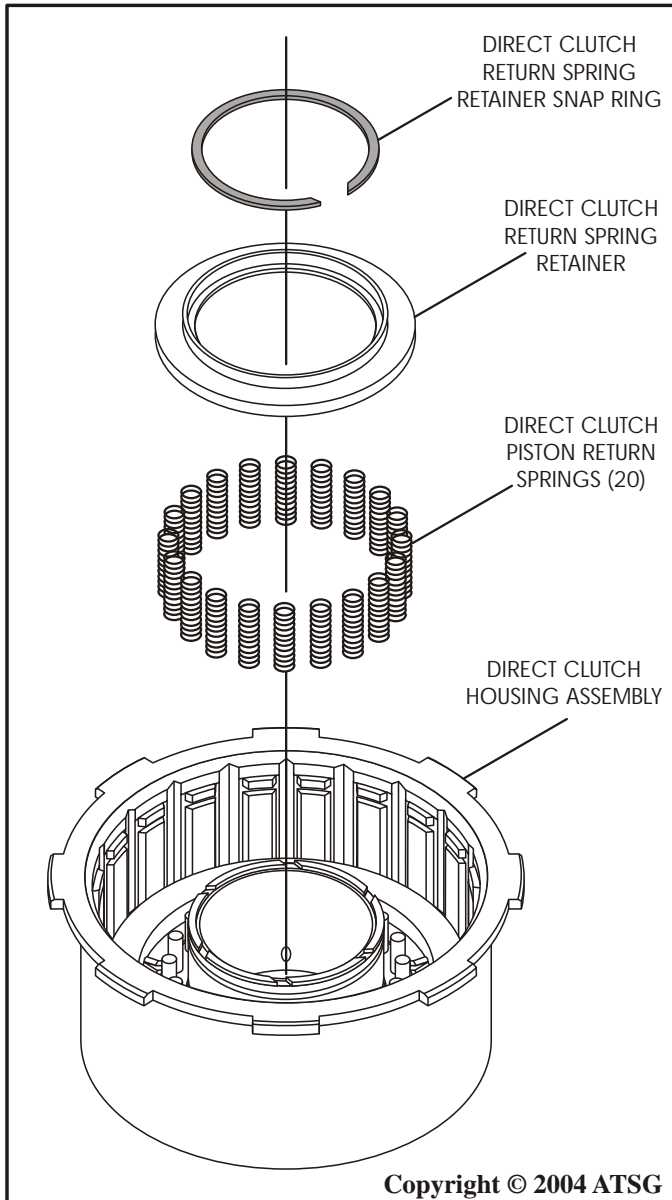

Figure 81

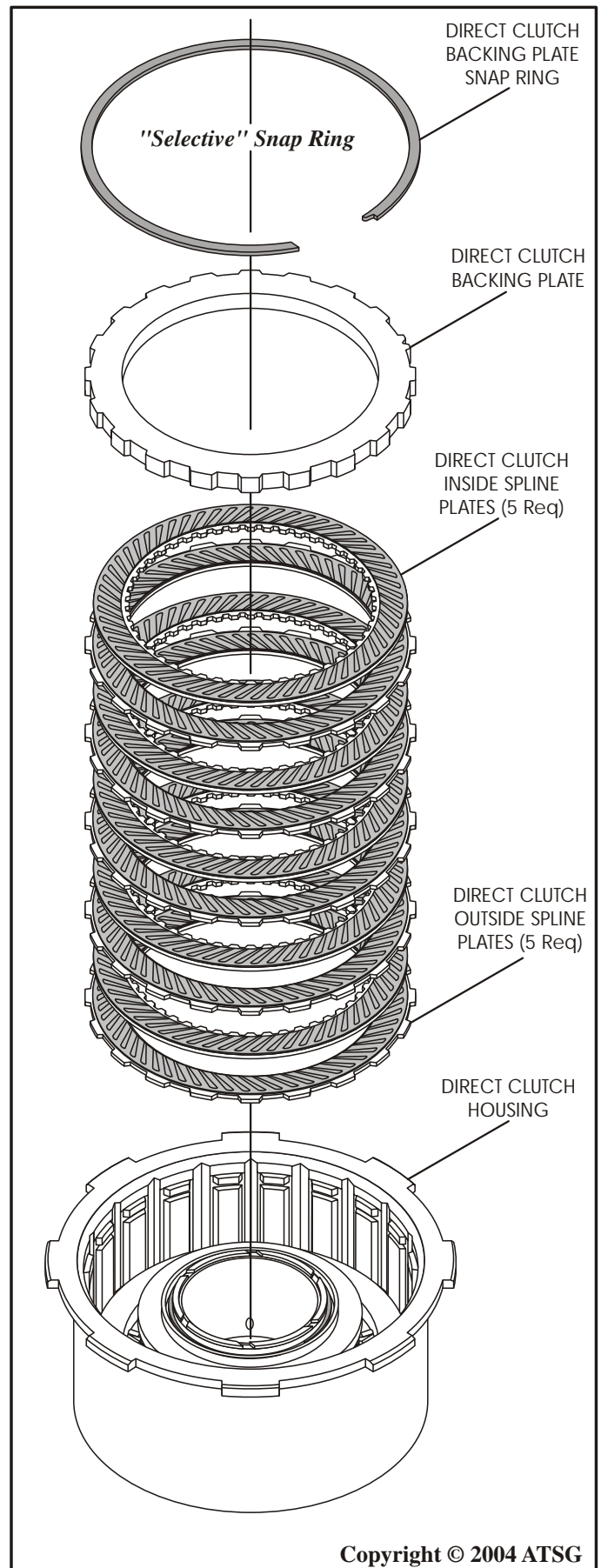
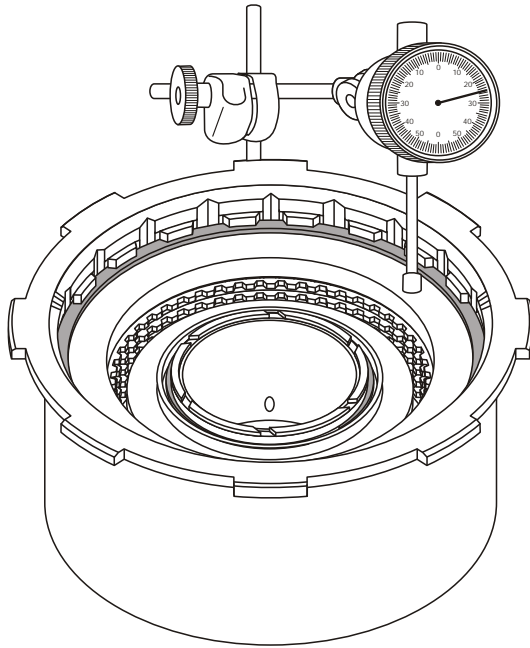

Figure 82

CHECKING DIRECT CLUTCH CLEARANCE
 CLEARANCE SHOULD BE 1.3 - 2.0mm (.051"-.079")



Part Number	Thickness	
	mm	in
E860126-S	1.37	.054"
E860127-S	1.73	.068"
E860128-S	2.08	.082"
E860129-S	2.44	.096"

Copyright © 2004 ATSG

Figure 83

ENSURE RINGS ROTATE FREELY

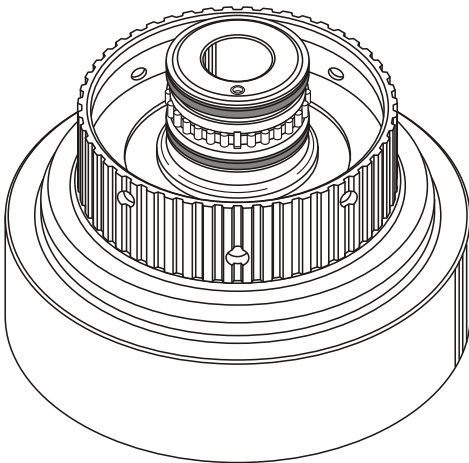

Copyright © 2004 ATSG

Figure 84

FORWARD CLUTCH HOUSING ASSEMBLY

1. Disassemble the forward clutch assembly using the illustrations in Figure 86 as a guide.
2. Inspect all forward clutch parts thoroughly for any wear and/or damage.
3. Clean all forward clutch parts thoroughly and dry with compressed air.
4. Install new sealing rings into their grooves on the forward clutch housing (See Figure 85).
5. Ensure that the sealing rings are seated and rotate freely in grooves (See Figure 84).

Continued on Page 54

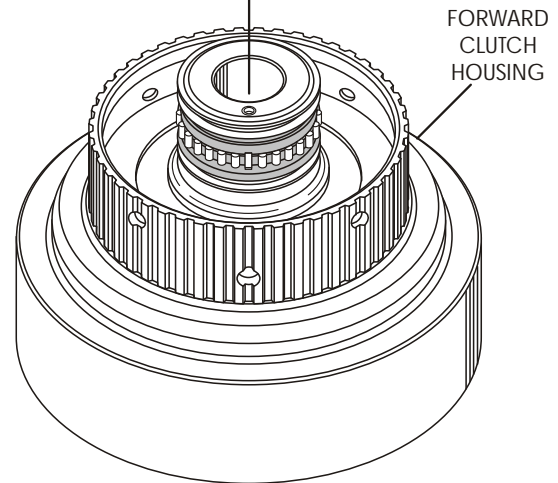
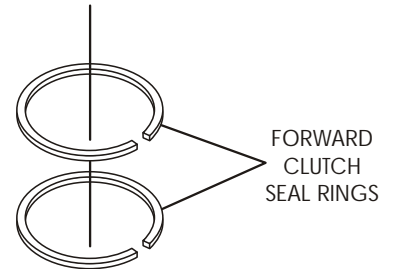

Copyright © 2004 ATSG

Figure 85

FORWARD CLUTCH ASSEMBLY EXPLODED VIEW

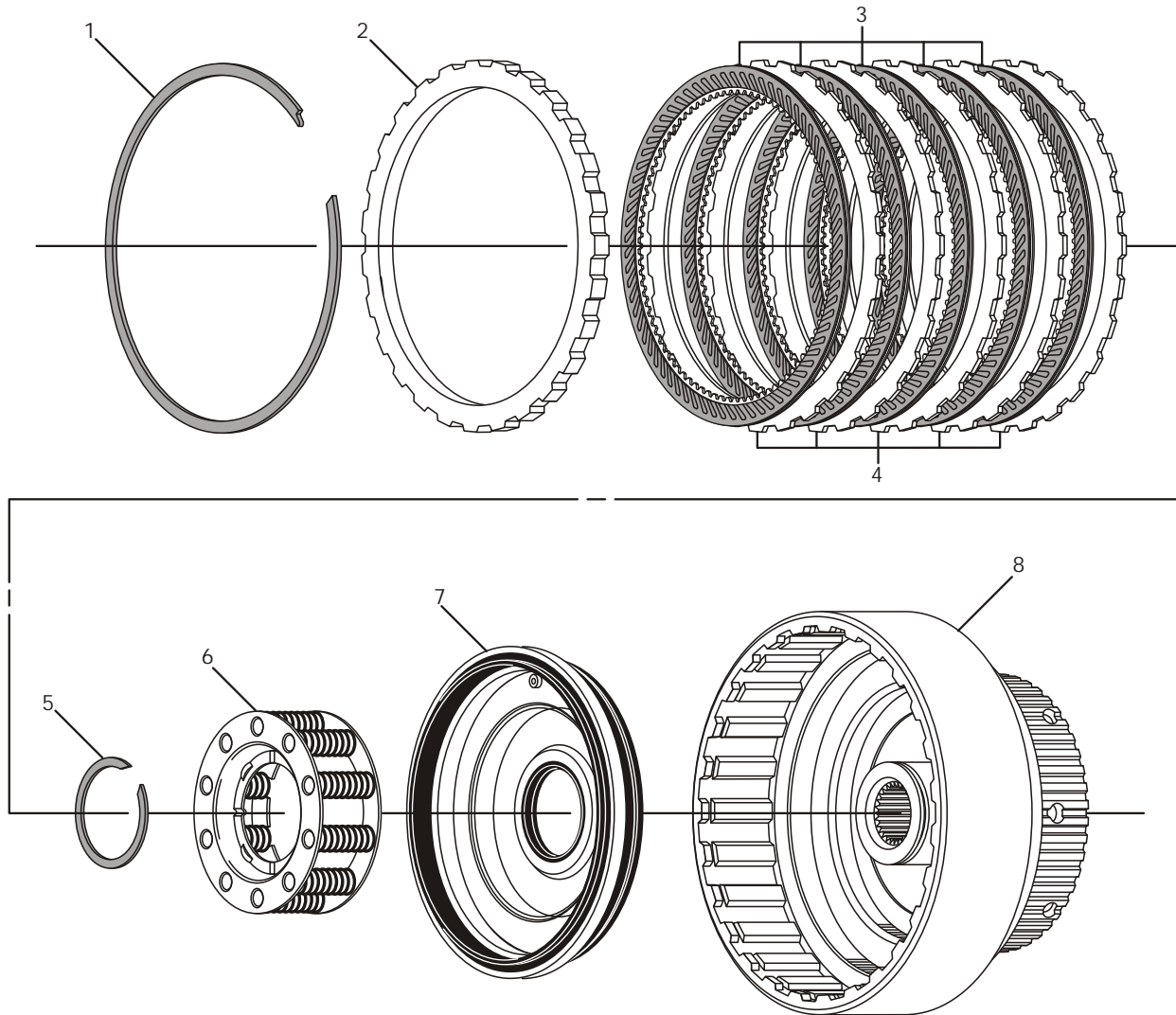

- 1. FORWARD CLUTCH BACKING PLATE "SELECTIVE" SNAP RING.
- 2. FORWARD CLUTCH BACKING PLATE.
- 3. FORWARD CLUTCH FRICTION PLATES.
- 4. FORWARD CLUTCH STEEL PLATES.

- 5. FORWARD CLUTCH RETURN SPRING RETAINER SNAP RING.
- 6. FORWARD CLUTCH PISTON RETURN SPRING ASSEMBLY.
- 7. FORWARD CLUTCH PISTON (STAMPED STEEL MOLDED RUBBER).
- 8. FORWARD CLUTCH HOUSING.

Copyright © 2004 ATSG

Figure 86

FORWARD CLUTCH HOUSING (Cont'd)

6. Lubricate both inner and outer lip seals on the stamped steel forward clutch piston assembly, as shown in Figure 87, with a small amount of Trans-Jel®.
7. Lubricate both seal surfaces in the housing with a small amount of Trans-Jel® and install the piston assembly with a twisting motion so as not to damage the seals (See Figure 87).
8. Install the return spring retainer assembly on top of the piston, as shown in Figure 88.
9. Compress the return springs and retainer and install the spring retainer snap ring, as shown in Figure 88, and ensure snap ring is seated.
10. Remove the spring compressor.
11. Install the forward clutch plates beginning with a steel plate and alternating with friction plates, until you have installed 5 of each, as shown in Figure 89.

CAUTION: *Forward Clutch friction plates are directional and must be installed with the grooves facing counterclockwise, as shown in Figure 90. Friction plates should be soaked in Mercon® V for 30 minutes before installing.*

12. Install forward clutch backing plate, as shown in Figure 89.

13. Install forward clutch backing plate snap ring, as shown in Figure 89 and ensure that it is fully seated in the groove.
14. Install dial indicator on top of backing plate, as shown in Figure 91, and check the amount of forward clutch clearance. Clearance should be 1.3 - 2.0mm (.051" - .079") (See Figure 91).
15. Change the selective backing plate snap ring as necessary, using the chart in Figure 91, to get the proper forward clutch clearance.
16. Set the completed forward clutch housing aside for the final assembly process.

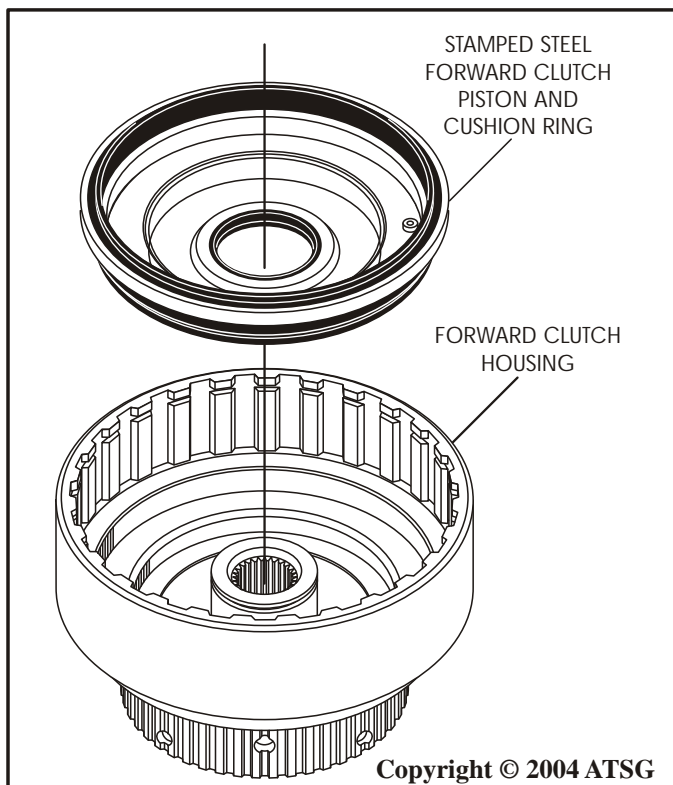

Figure 87

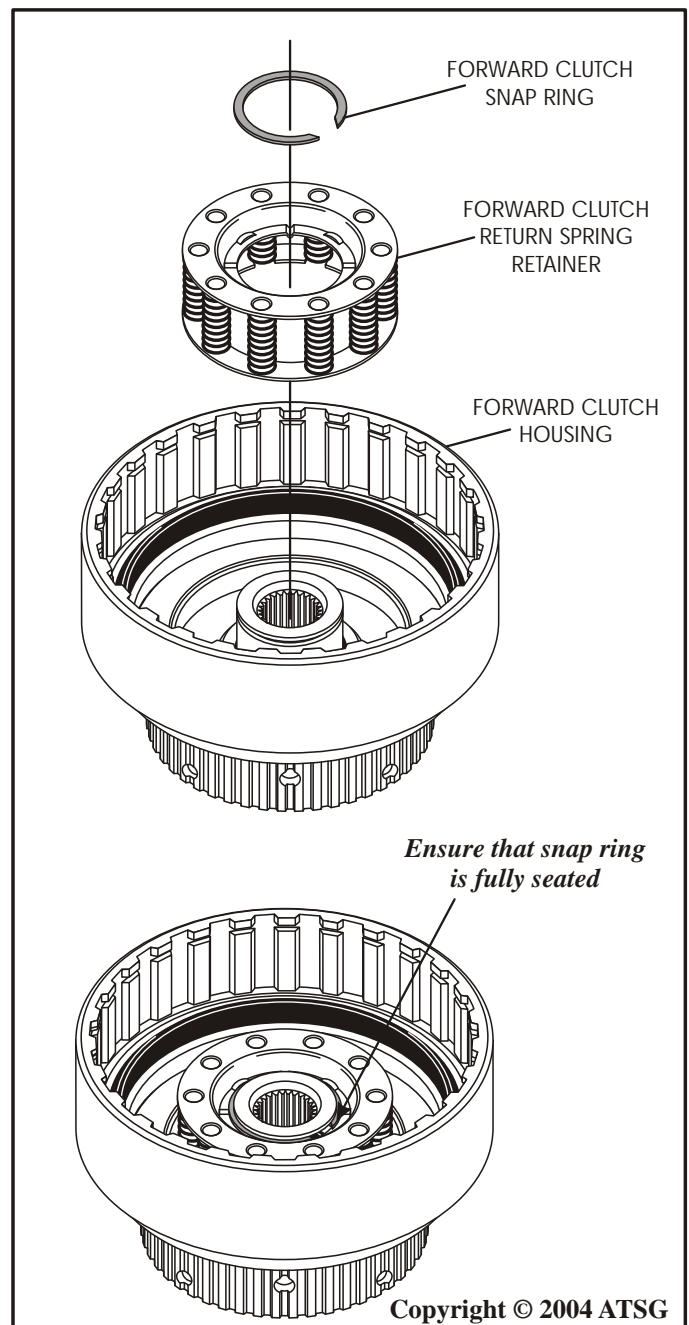

Figure 88

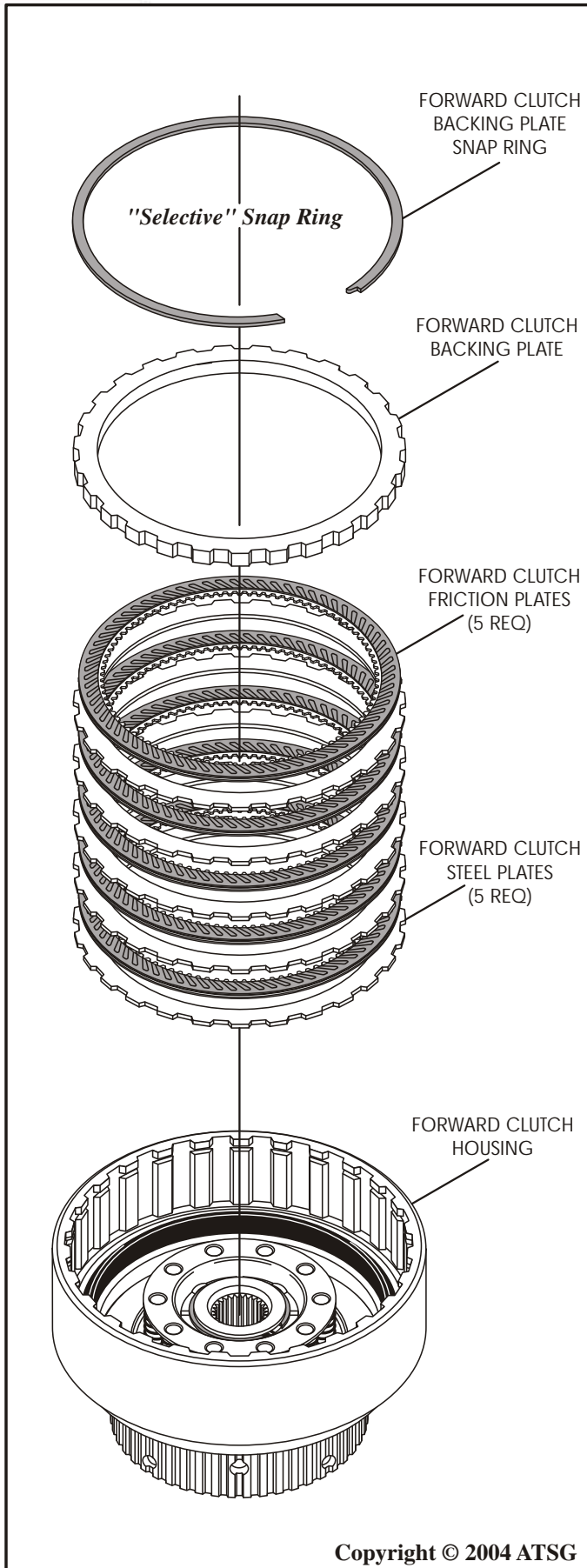

Figure 89

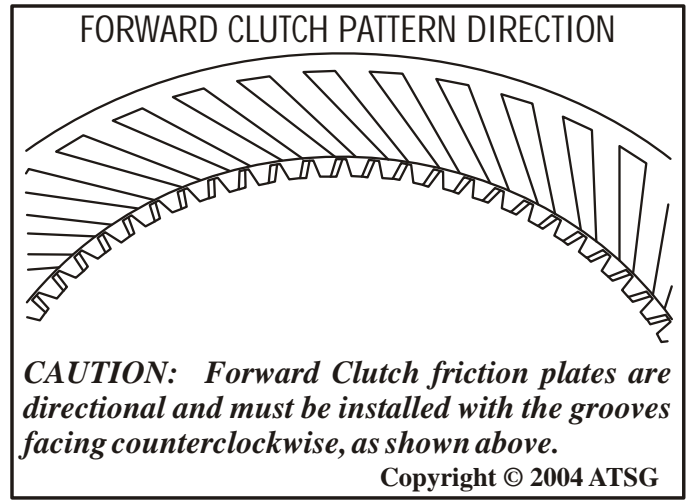

Figure 90

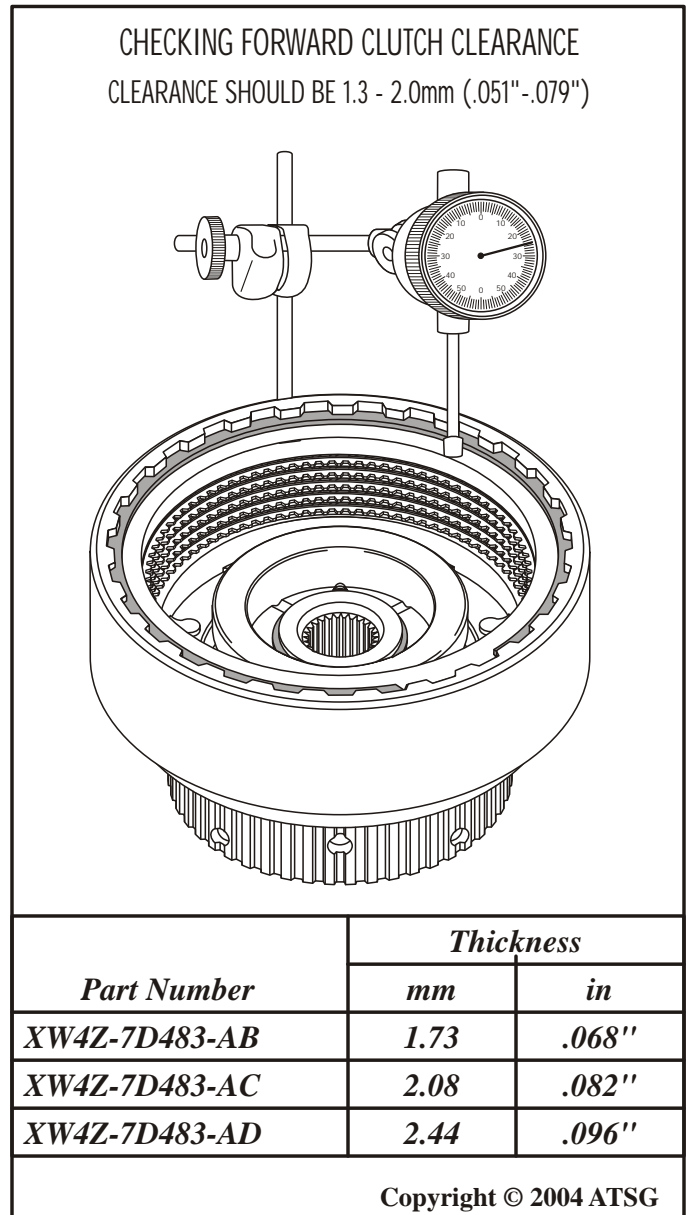

Figure 91

CHECK CENTER SUPPORT BEARING RACE FOR CRACKS

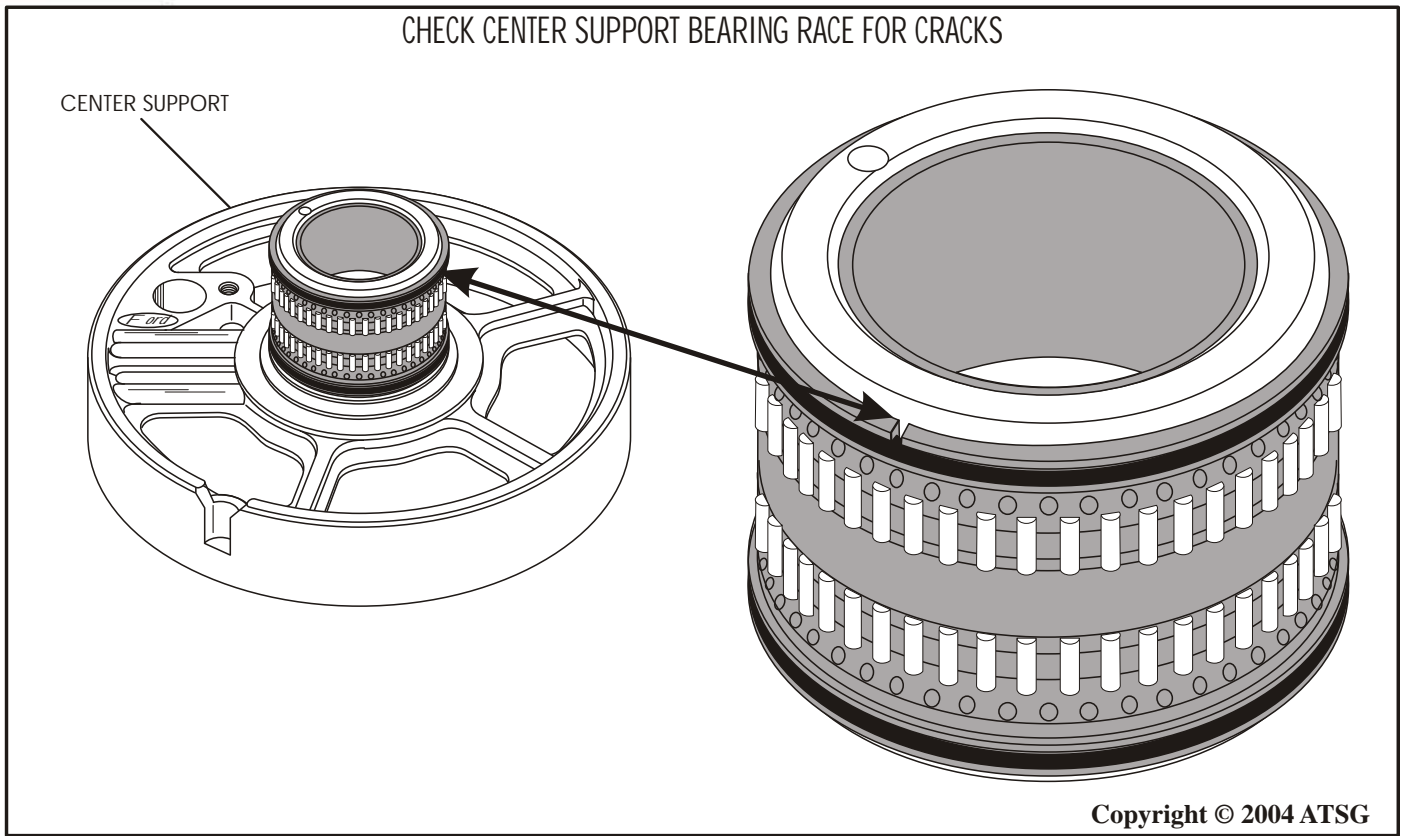

Figure 92

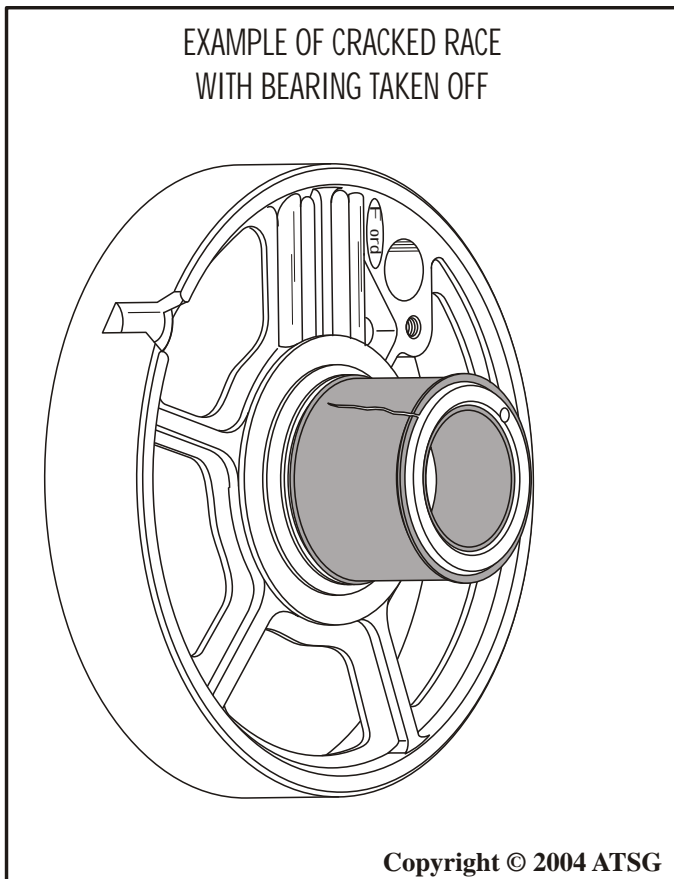

Figure 94

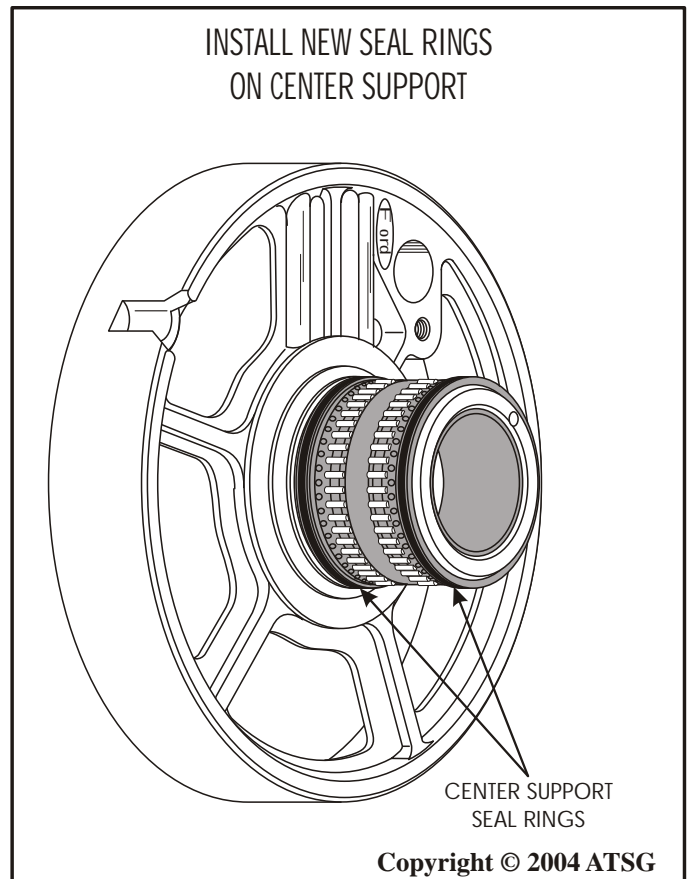

Figure 95

CENTER SUPPORT ASSEMBLY

1. The center support assembly will require some ***extra inspection*** to ensure it's integrity.
 2. Inspect bearing race at the top of the bearing, as shown in Figure 93, for any visable cracks.
 3. If there are any visable cracks, replacement of complete center support will be necessary, as the bearing is not available as a service item.
 4. We have seen several supports with the bearing race cracked, as shown in Figure 94. This will create leakage of direct and forward clutch oil, into each others circuit.
 5. If you cannot visually see any crack, install new sealing rings onto the center support, as shown in Figure 95.
 6. The ***only positive way*** to verify the integrity of the center support, is to assemble the forward and direct clutch housings, with the appropriate thrust bearings, onto the support, as shown in Figure 96.
 7. Now air check the direct and forward clutch passages to ensure these passages are not connected.
- Caution: This air check should be performed with every center support assembly, and then replaced as necessary.***
8. After you have verified the integrity of center support assembly, set the completed support aside for the final assembly process.

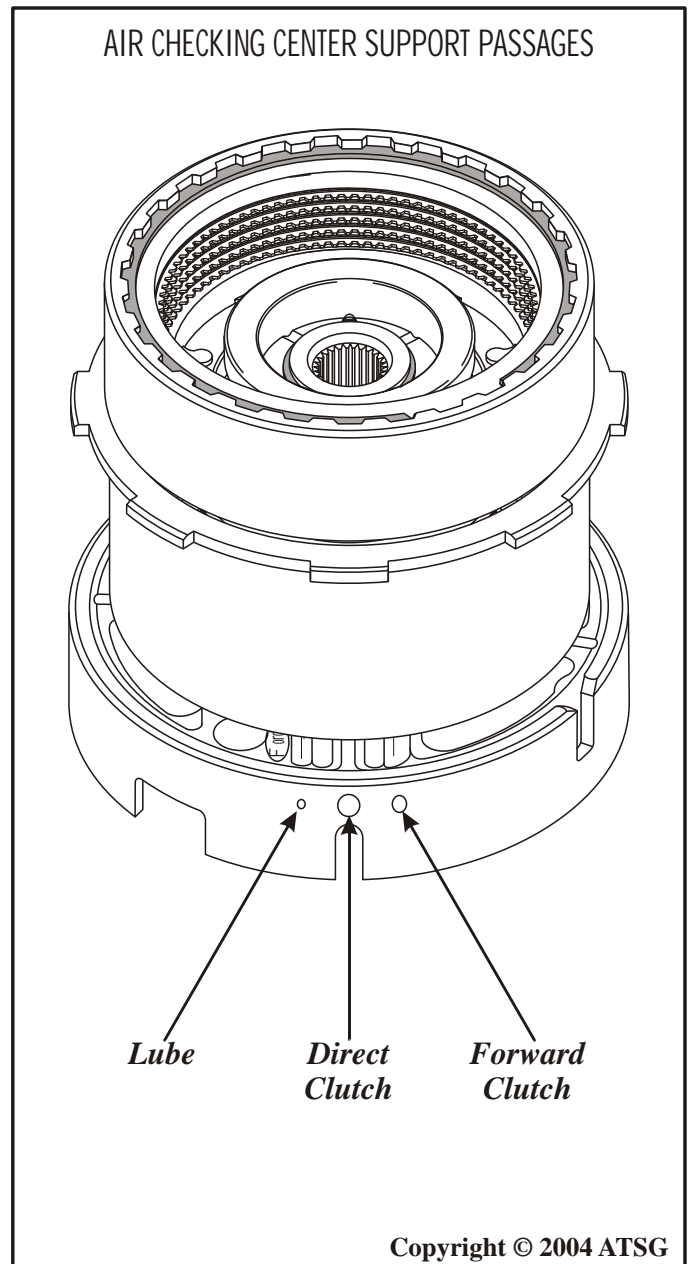

Figure 96

LOW SPRAG AND REVERSE DRUM ASSEMBLY

1. The low sprag assembly is not yet available as a service item. If the low sprag or the bearing assembly needs replacement, the complete reverse drum assembly must be purchased.
2. If you do take it apart, the bearing assembly must be installed first, in the direction shown in Figure 97.
3. Then install the low sprag assembly, with the tabs facing down, as shown in Figure 97, until it "Snaps" into the groove.
4. After inspection and re-assembly if necessary, set the completed reverse drum assembly aside for the final assembly process (See Figure 98).

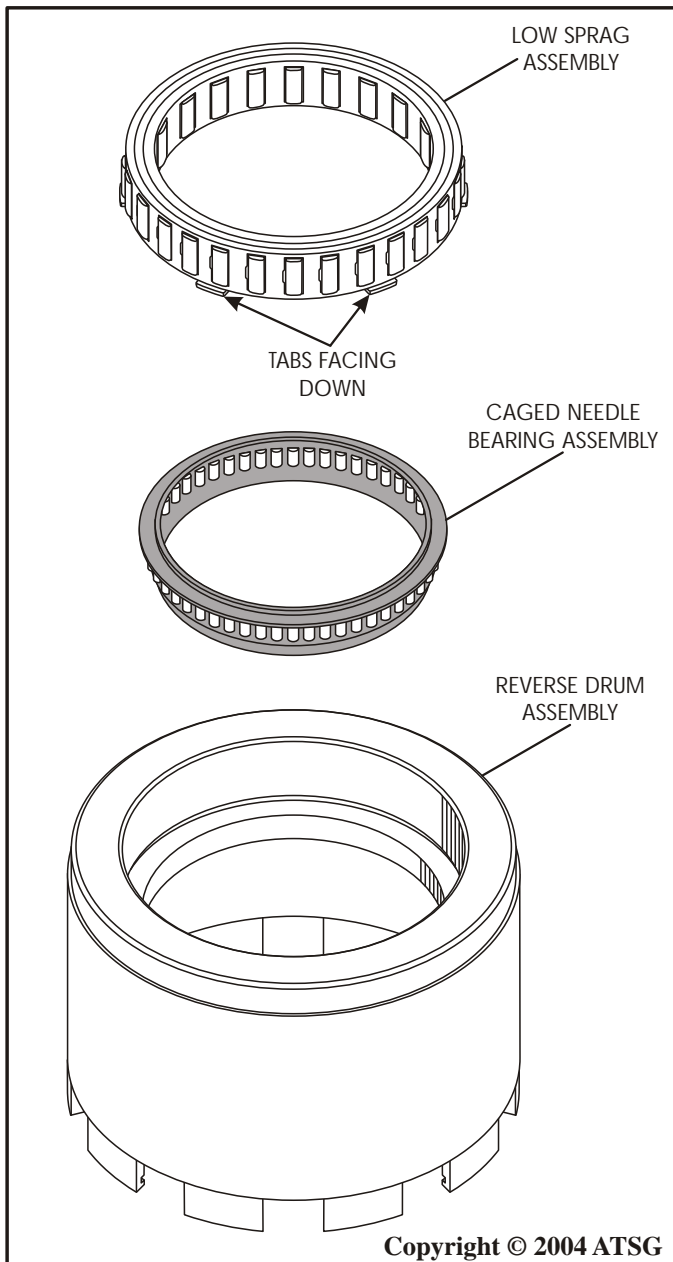

Figure 97

REAR RING GEAR AND HUB ASSEMBLY

1. Inspect all rear ring gear parts thoroughly as shown in Figure 99.
2. Remove and discard the sealing ring on the rear gear hub, as shown in Figure 99.
3. Assemble the rear ring gear hub into the rear ring gear and install the snap ring, as shown in Figure 99.
4. Install a new sealing ring into the groove in the ring gear hub, as shown in Figure 99.
Caution: This sealing ring is manufactured with two small notches in the outside diameter as shown in Figure 100, and must be installed in this location.
5. Set completed rear ring gear and hub assembly, as shown in Figure 101, aside for the final assembly process.

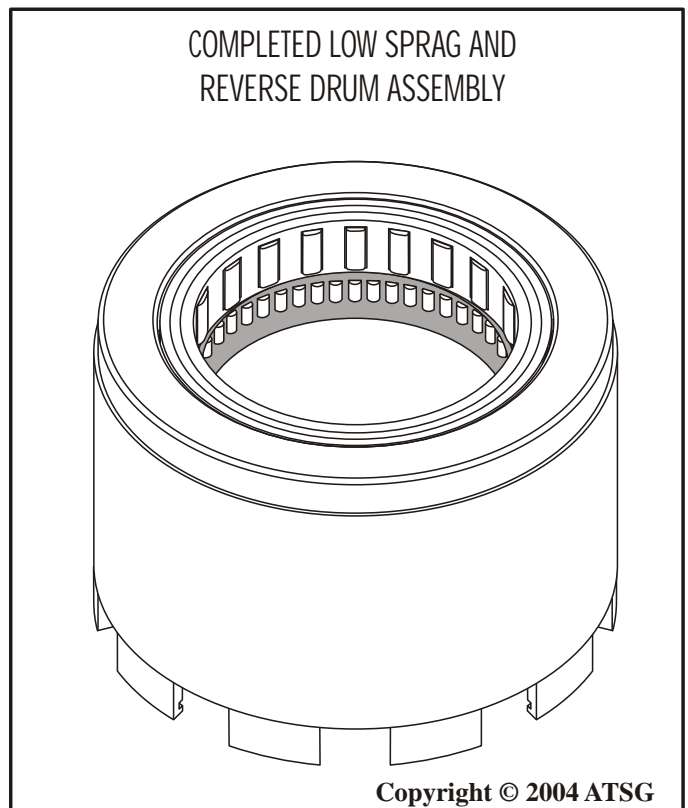

Figure 98

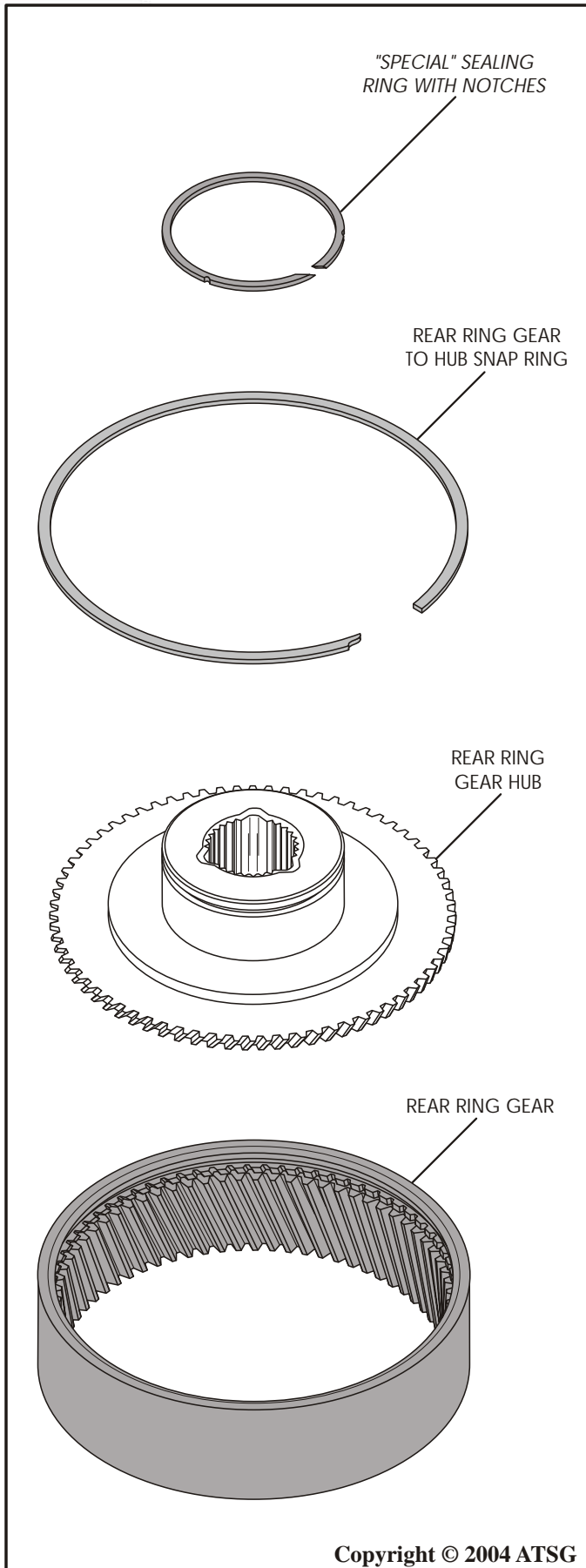

Figure 99

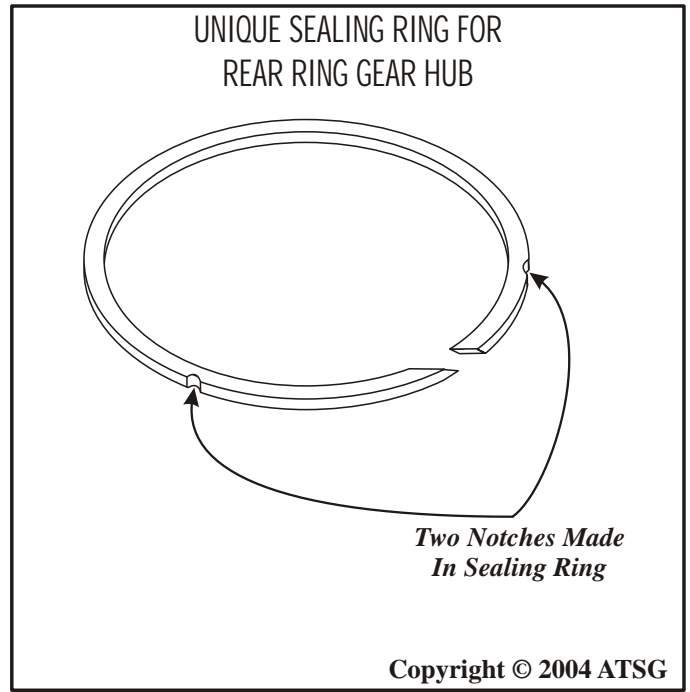

Figure 100

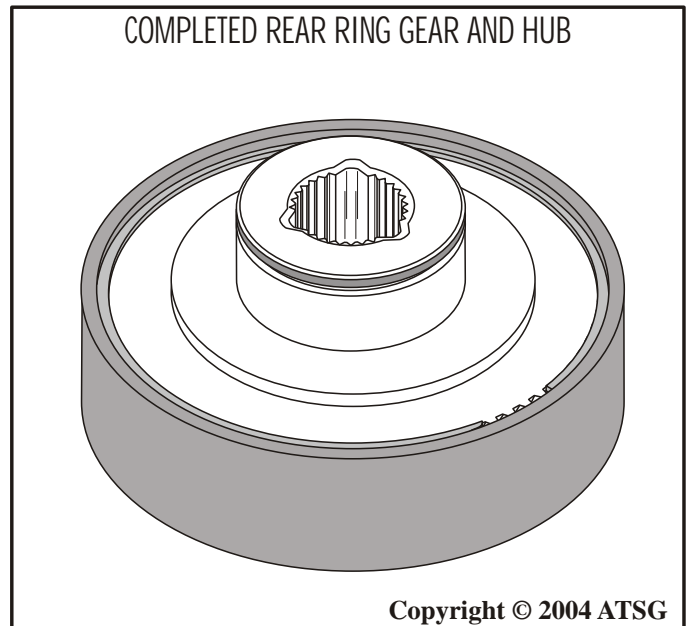

Figure 101

FRONT PLANETARY CARRIER ASSEMBLY

1. Inspect the front planetary carrier carefully for any wear and/or damage (See Figure 102).
2. Inspect the rear planetary carrier thrust bearing that is "Trapped" inside the planetary gears, for any wear and/or damage.
3. Inspect the front planetary carrier thrust washer for any wear and/or damage (See Figure 102).
4. Replace the thrust washer as necessary.
5. Install the front planetary carrier thrust washer by "Snapping" the tabs into place, as shown in Figure 102.
6. Set completed front planetary carrier assembly aside for the final assembly process. Refer to Figure 103.

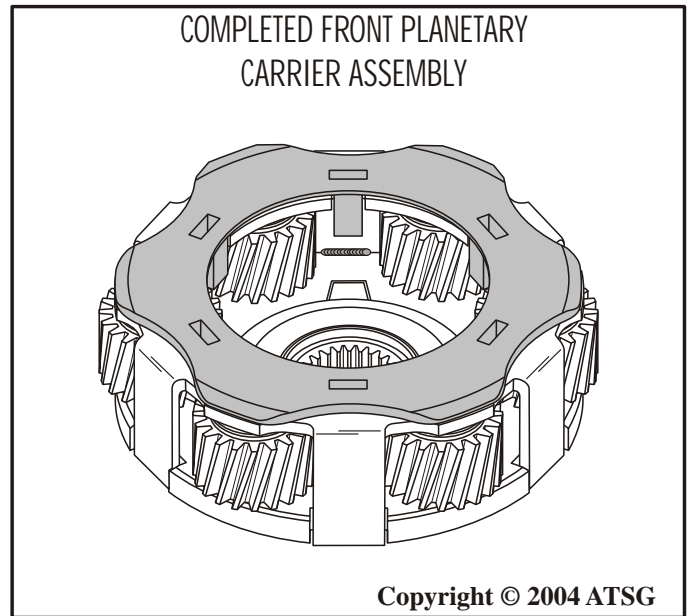

Figure 103

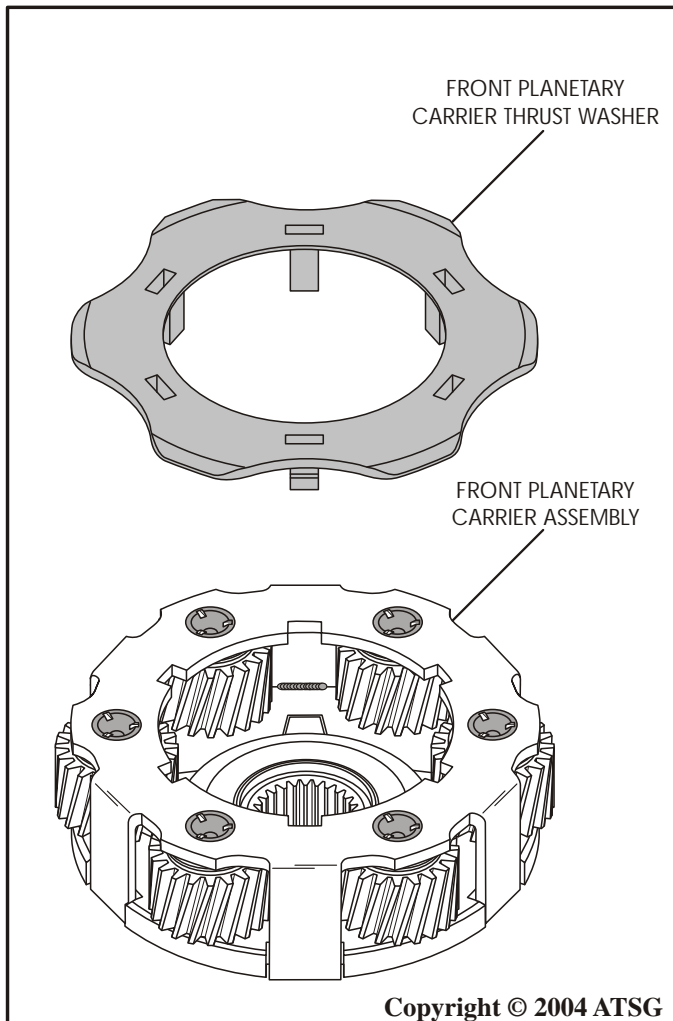

Figure 102

REAR PLANETARY CARRIER ASSEMBLY

1. Inspect the rear planetary carrier carefully for any wear and/or damage (See Figure 104).
2. Set completed rear planetary carrier assembly aside for the final assembly process. Refer to Figure 104.

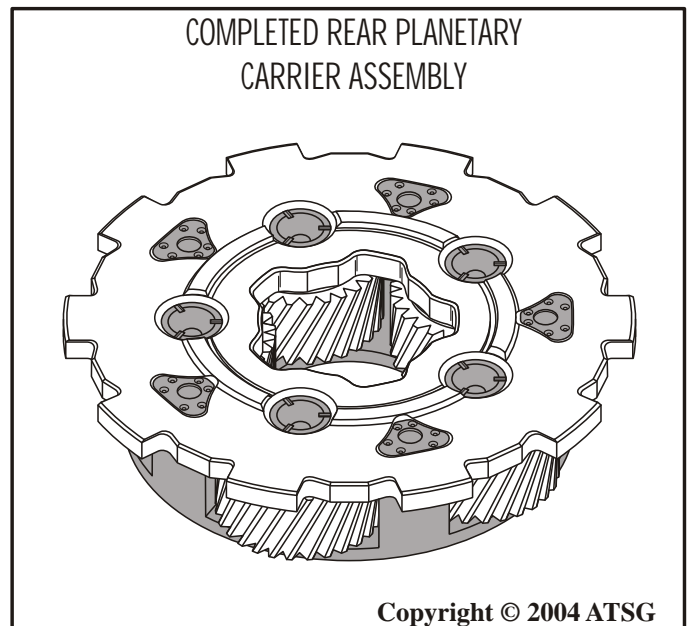

Figure 104

SUN GEAR AND SHELL ASSEMBLY

1. The sun gear and shell cannot be disassembled. Refer to Figure 105.
2. Inspect the sun gear and shell parts thoroughly for any wear and/or damage.
3. Clean all sun gear shell parts thoroughly and dry with compressed air.

FRONT RING GEAR AND HUB ASSEMBLY

1. Inspect all rear ring gear parts thoroughly as shown in Figure 106.
2. Assemble the rear ring gear hub into the rear ring gear and install the snap ring, as shown in Figure 106.
3. Install the number 6B thrust washer into the ring gear hub, as shown in Figure 106, retain with small amount of Trans-Jel®.
4. Set completed rear ring gear and hub assembly, as shown in Figure 106, aside for the final assembly process.
5. Refer to Figure 107 and 108 for exploded view of complete gear train parts.

**Component Rebuild
Continued on Page 64**

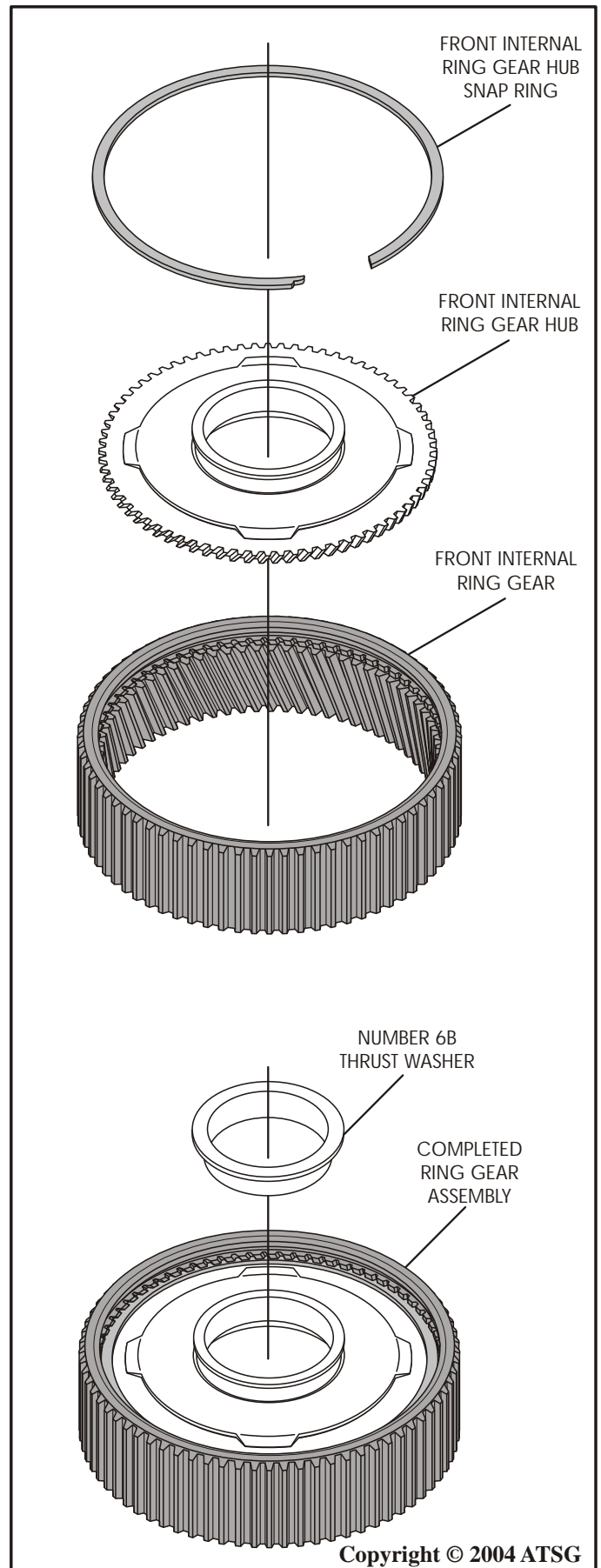

Figure 106

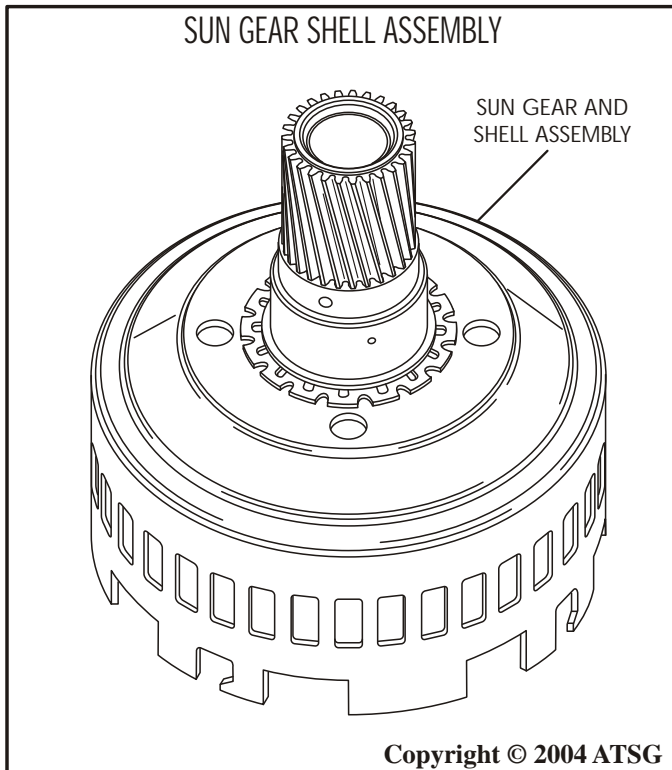
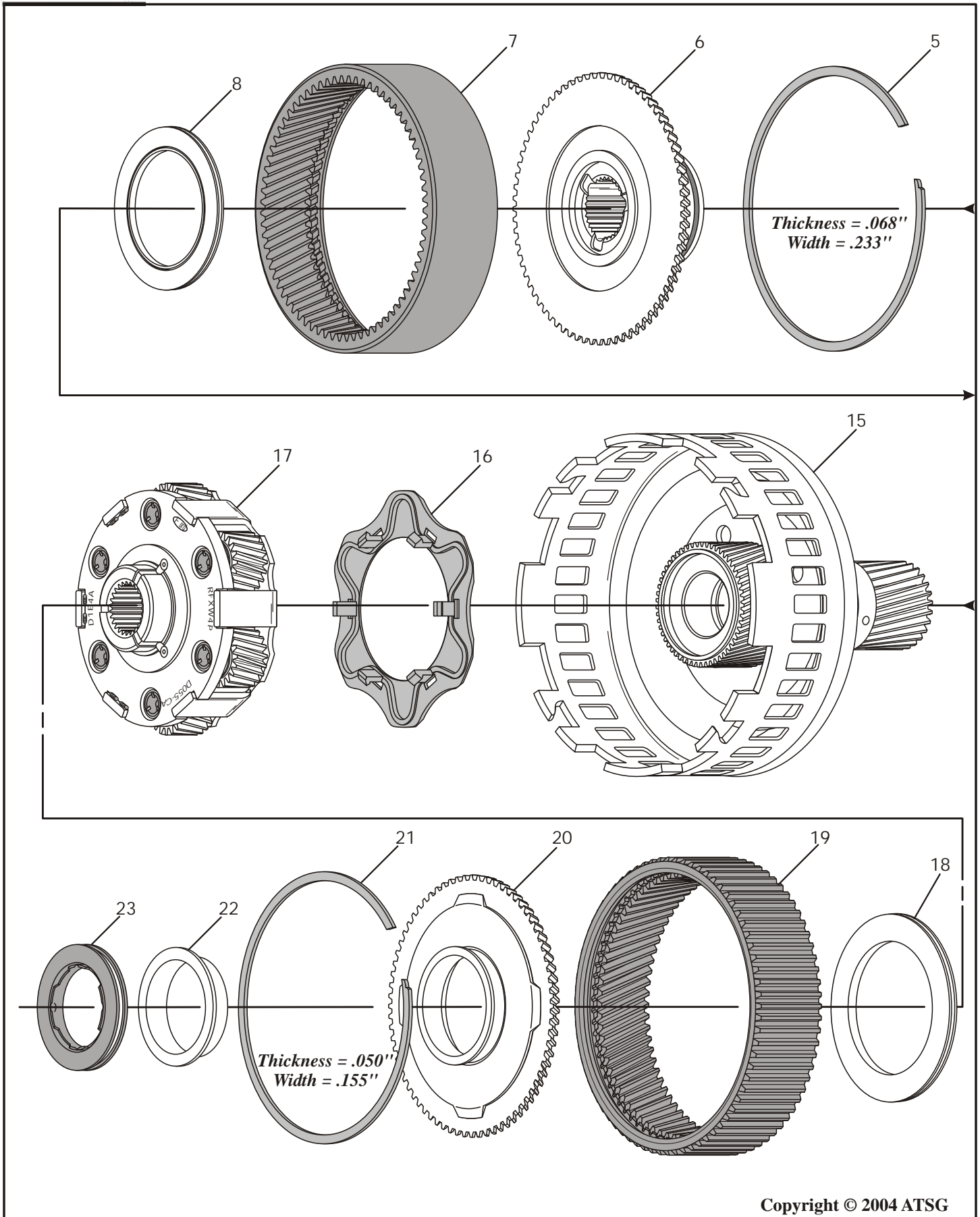
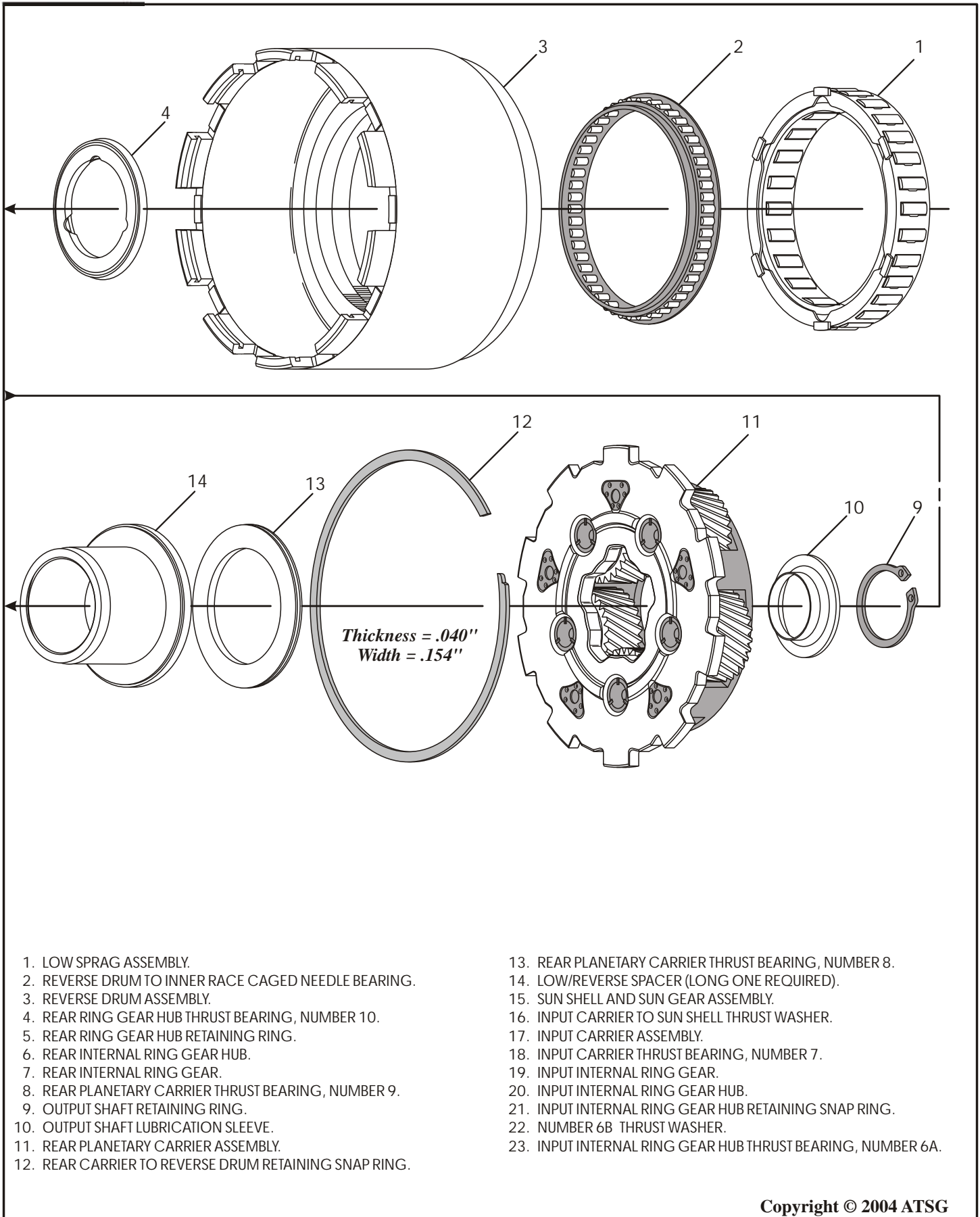

Figure 105



Copyright © 2004 ATSG

Figure 107



- 1. LOW SPRAG ASSEMBLY.
- 2. REVERSE DRUM TO INNER RACE CAGED NEEDLE BEARING.
- 3. REVERSE DRUM ASSEMBLY.
- 4. REAR RING GEAR HUB THRUST BEARING, NUMBER 10.
- 5. REAR RING GEAR HUB RETAINING RING.
- 6. REAR INTERNAL RING GEAR HUB.
- 7. REAR INTERNAL RING GEAR.
- 8. REAR PLANETARY CARRIER THRUST BEARING, NUMBER 9.
- 9. OUTPUT SHAFT RETAINING RING.
- 10. OUTPUT SHAFT LUBRICATION SLEEVE.
- 11. REAR PLANETARY CARRIER ASSEMBLY.
- 12. REAR CARRIER TO REVERSE DRUM RETAINING SNAP RING.

- 13. REAR PLANETARY CARRIER THRUST BEARING, NUMBER 8.
- 14. LOW/REVERSE SPACER (LONG ONE REQUIRED).
- 15. SUN SHELL AND SUN GEAR ASSEMBLY.
- 16. INPUT CARRIER TO SUN SHELL THRUST WASHER.
- 17. INPUT CARRIER ASSEMBLY.
- 18. INPUT CARRIER THRUST BEARING, NUMBER 7.
- 19. INPUT INTERNAL RING GEAR.
- 20. INPUT INTERNAL RING GEAR HUB.
- 21. INPUT INTERNAL RING GEAR HUB RETAINING SNAP RING.
- 22. NUMBER 6B THRUST WASHER.
- 23. INPUT INTERNAL RING GEAR HUB THRUST BEARING, NUMBER 6A.

Copyright © 2004 ATSG

Figure 108

VALVE BODY ASSEMBLY EXPLODED VIEW

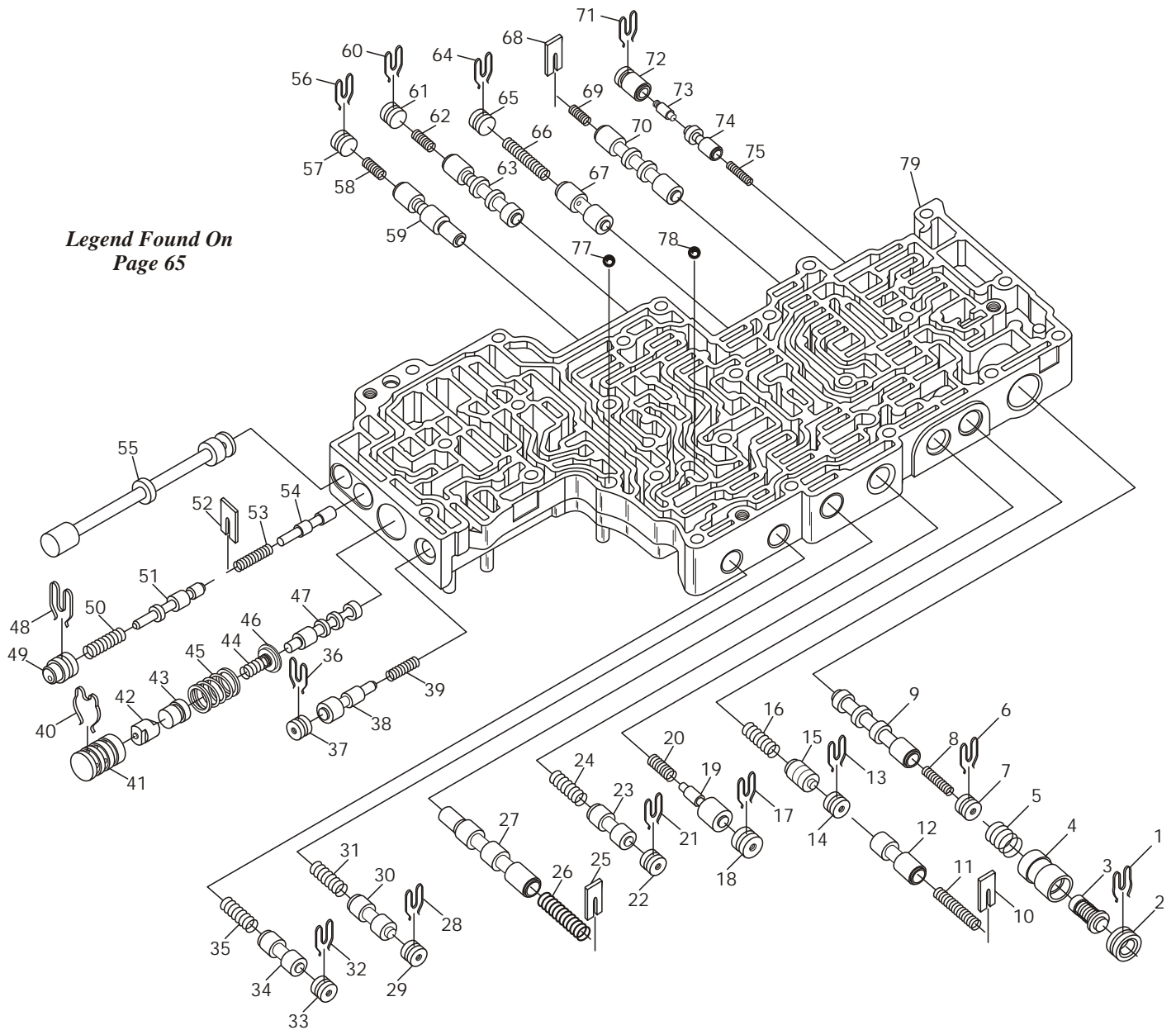

Legend Found On
Page 65

Figure 109



Technical Service Information

VALVE BODY ASSEMBLY

1. Disassemble the main valve body assembly using Figure 109 as a guide.
2. Lay each valve line-up out in order as you remove them from the valve body casting.
3. Inspect each valve, valve spring, bore plug and retainers for any wear and/or damage. Replace complete valve body as necessary.
4. Clean all valve body parts thoroughly and dry with compressed air.
5. Install each valve train back into their bores **exactly** as shown in Figure 109, lubricating them with Mercon V® as they are installed.

6. Refer to Figure 110 for the **exact** placement of retaining pins and clips, as some of them are installed inboard in the worm tracks of the valve body casting.
7. Extra care here will eliminate some of the troublesome problems encountered later.

Continued on Page 66

VALVE BODY LEGEND FOR 5R55W/S

- | | |
|--|---|
| 1 COOLER BYPASS VALVE RETAINER CLIP | 40 MAIN REGULATOR BOOST VALVE SLEEVE RETAINER CLIP |
| 2 COOLER BYPASS VALVE BORE PLUG | 41 MAIN REGULATOR BOOST VALVE SLEEVE |
| 3 THERMO VALVE ASSEMBLY | 42 MAIN REGULATOR BOOST VALVE |
| 4 COOLER BYPASS VALVE | 43 MAIN REGULATOR BOOST VALVE |
| 5 COOLER BYPASS VALVE SPRING | 44 MAIN REGULATOR BOOST VALVE INNER SPRING |
| 6 CONVERTER CLUTCH CONTROL VALVE RETAINER | 45 MAIN REGULATOR BOOST VALVE OUTER SPRING |
| 7 CONVERTER CLUTCH CONTROL VALVE BORE PLUG | 46 MAIN REGULATOR BOOST VALVE SPRING RETAINER |
| 8 CONVERTER CLUTCH CONTROL VALVE SPRING | 47 MAIN REGULATOR VALVE |
| 9 CONVERTER CLUTCH CONTROL VALVE | 48 CONVERTER LIMIT VALVE RETAINER CLIP |
| 10 COAST CLUTCH CONTROL VALVE RETAINER PLACE | 49 CONVERTER LIMIT VALVE BORE PLUG |
| 11 COAST CLUTCH CONTROL VALVE SPRING | 50 CONVERTER LIMIT VALVE SPRING |
| 12 COAST CLUTCH CONTROL VALVE | 51 CONVERTER LIMIT VALVE |
| 13 CONVERTER CLUTCH BACK PRESSURE VALVE RETAINER CLIP | 52 SOLENOID REGULATOR VALVE RETAINER PLATE |
| 14 CONVERTER CLUTCH BACK PRESSURE VALVE BORE PLUG | 53 SOLENOID REGULATOR VALVE SPRING |
| 15 CONVERTER CLUTCH BACK PRESSURE VALVE | 54 SOLENOID REGULATOR VALVE |
| 16 CONVERTER CLUTCH BACK PRESSURE VALVE SPRING | 55 MANUAL SHIFT CONTROL VALVE |
| 17 VARIABLE FORCE SOLENOID 2 MODULATOR VALVE RETAINER CLIP | 56 REAR SERVO CONTROL VALVE RETAINER CLIP |
| 18 VARIABLE FORCE SOLENOID 2 MODULATOR VALVE BORE PLUG | 57 REAR SERVO CONTROL VALVE BORE PLUG |
| 19 VARIABLE FORCE SOLENOID 2 MODULATOR VALVE | 58 REAR SERVO CONTROL VALVE SPRING |
| 20 VARIABLE FORCE SOLENOID 2 MODULATOR VALVE SPRING | 59 REAR SERVO CONTROL VALVE |
| 21 INTERMEDIATE SERVO RELEASE VALVE RETAINER CLIP | 60 REAR SERVO/INT. SERVO APPLY SELECT VALVE RETAINER CLIP |
| 22 INTERMEDIATE SERVO RELEASE VALVE BORE PLUG | 61 REAR SERVO/INT. SERVO APPLY SELECT VALVE BORE PLUG |
| 23 INTERMEDIATE SERVO RELEASE VALVE | 62 REAR SERVO/INT. SERVO APPLY SELECT VALVE SPRING |
| 24 INTERMEDIATE SERVO RELEASE VALVE SPRING | 63 REAR SERVO/INT. SERVO APPLY SELECT VALVE |
| 25 HIGH CLUTCH CONTROL VALVE RETAINER PLATE | 64 FORWARD ENGAGEMENT CONTROL VALVE RETAINER CLIP |
| 26 HIGH CLUTCH CONTROL VALVE SPRING | 65 FORWARD ENGAGEMENT CONTROL VALVE BORE PLUG |
| 27 HIGH CLUTCH CONTROL VALVE | 66 FORWARD ENGAGEMENT CONTROL VALVE SPRING |
| 28 REVERSE MODULATOR VALVE RETAINER CLIP | 67 FORWARD ENGAGEMENT CONTROL VALVE |
| 29 REVERSE MODULATOR VALVE BORE PLUG | 68 OVERDRIVE SERVO CONTROL VALVE RETAINER PLATE |
| 30 REVERSE MODULATOR VALVE | 69 OVERDRIVE SERVO CONTROL VALVE SPRING |
| 31 REVERSE MODULATOR VALVE SPRING | 70 OVERDRIVE SERVO CONTROL VALVE |
| 32 REVERSE ENGAGEMENT VALVE RETAINER CLIP | 71 TCC MODULATOR CONTROL VALVE RETAINER CLIP |
| 33 REVERSE ENGAGEMENT VALVE BORE PLUG | 72 TCC MODULATOR CONTROL VALVESLEEVE |
| 34 REVERSE ENGAGEMENT VALVE | 73 TCC MODULATOR CONTROL VALVE |
| 35 REVERSE ENGAGEMENT VALVE SPRING | 74 TCC MODULATOR CONTROL VALVE |
| 36 VARIABLE FORCE SOLENOID 1 MODULATOR VALVE RETAINER CLIP | 75 TCC MODULATOR CONTROL VALVE SPRING |
| 37 VARIABLE FORCE SOLENOID 1 MODULATOR VALVE BORE PLUG | 77 .250" DIAMETER CHECKBALL |
| 38 VARIABLE FORCE SOLENOID 1 MODULATOR VALVE | 78 .250" DIAMETER CHECKBALL |
| 39 VARIABLE FORCE SOLENOID 1 MODULATOR VALVE SPRING | 79 VALVE BODY CASTING |

Copyright © 2004 ATSG

Figure 109 "LEGEND"

VALVE BODY ASSEMBLY (Cont'd)

8. Ensure that the valve train retainers have been installed in their proper locations, as shown in Figure 110.
- Note: The numbers in Figure 110 refer to the illustration numbers in the legend on Page 65.**
9. Lubricate all installed valve trains with a small amount of Mercon V®, before installing the valve body spacer plate.
10. Install the two .250" Viton checkballs into the locations shown in Figure 110 and 111.
11. Install two valve body spacer plate alignment dowels in the locations shown in Figure 111.
12. **Special Note: The valve body spacer plate has bonded gaskets on both sides, and Ford Motor Co. recommends replacement of the spacer plate on all rebuilds.**
13. Most aftermarket gasket kits come equipped with new valve body gaskets, but the top and bottom gaskets are different.
14. These new gaskets may be used if you can successfully remove the old gaskets without damage to the spacer plate.
15. Install the new gaskets on the proper sides of spacer plate and place over alignment dowels, or install a new Ford spacer plate assembly, as shown in Figure 111.
16. Install the three spacer plate retaining bolts, as shown in Figure 111, and torque the bolts to 10 Nm (89 in.lb.).
17. Remove the alignment dowels and set the completed valve body assembly aside for the final assembly process.

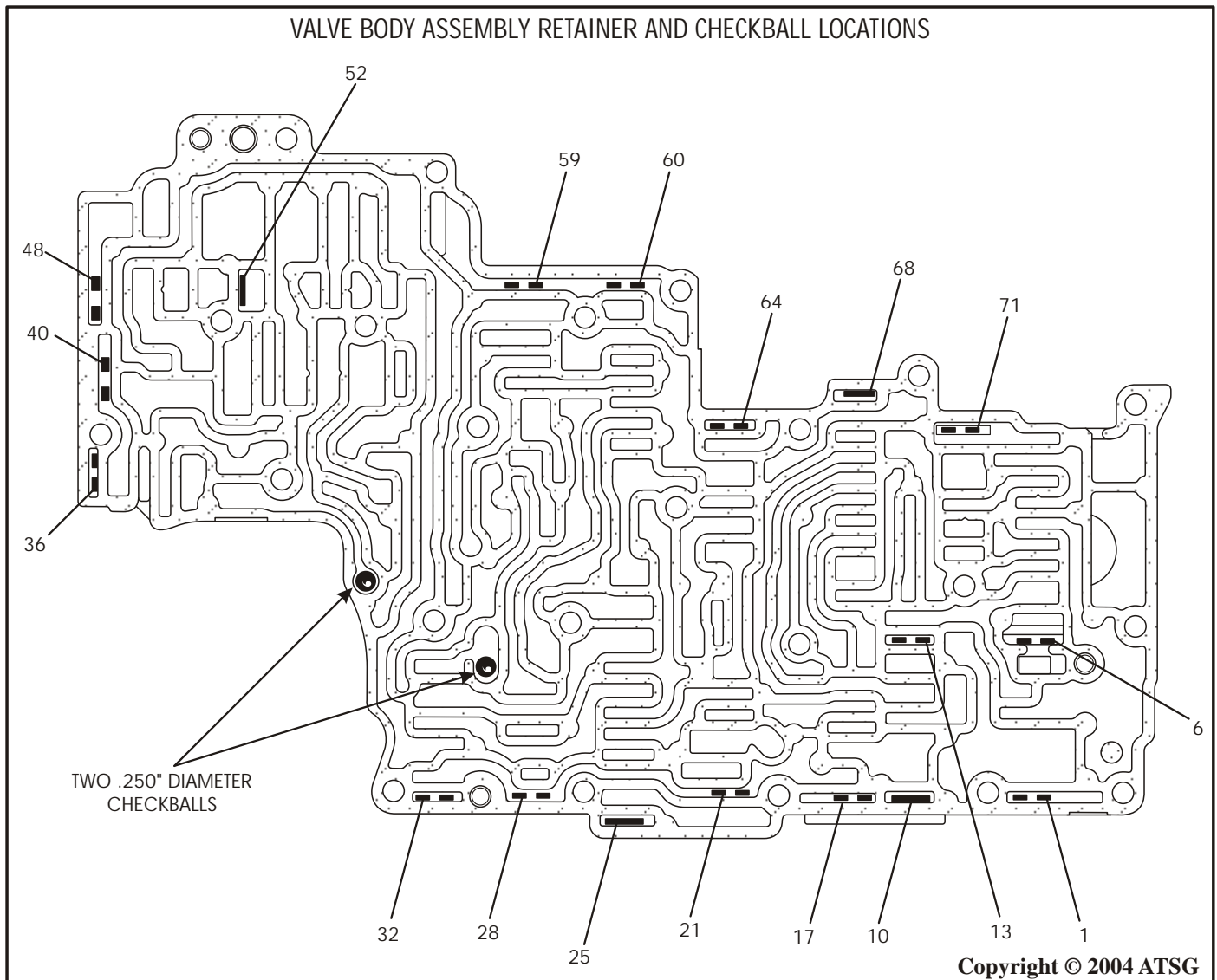

Figure 110

VALVE BODY SPACER PLATE AND GASKETS

SPACER PLATE
RETAINING BOLT
(3 REQUIRED)

SPACER PLATE
RETAINING BOLT
(3 REQUIRED)

"NEW" SPACER PLATE WITH BONDED GASKETS
OR CLEAN PLATE WITH AFTERMARKET GASKETS

.250" VITON BALLS
(2 REQUIRED)

ALIGNMENT DOWEL
(2 REQUIRED)

ALIGNMENT DOWEL
(2 REQUIRED)

Copyright © 2004 ATSG

Figure 111

REVERSE SERVO ASSEMBLY

1. Disassemble the reverse servo assembly using Figure 113 as a guide.
2. Tabs on the reverse servo cover plate mate with slots in the reverse housing every 120 degrees.
3. Remove reverse servo cover plate by turning in either direction to release. Align the arrow on the cover plate with any slot on the housing, as shown in Figure 112.
4. Inspect all reverse servo parts thoroughly for any wear and/or damage.
Note: The reverse servo piston has a molded seal, as shown in Figure 113. Replace the piston assembly as necessary.
5. Remove and discard the reverse servo piston inner "D" ring seal from the servo housing, as shown in Figure 113.
6. Remove and inspect the reverse servo check valve and spring, as shown in Figure 113.

Continued on Page 69

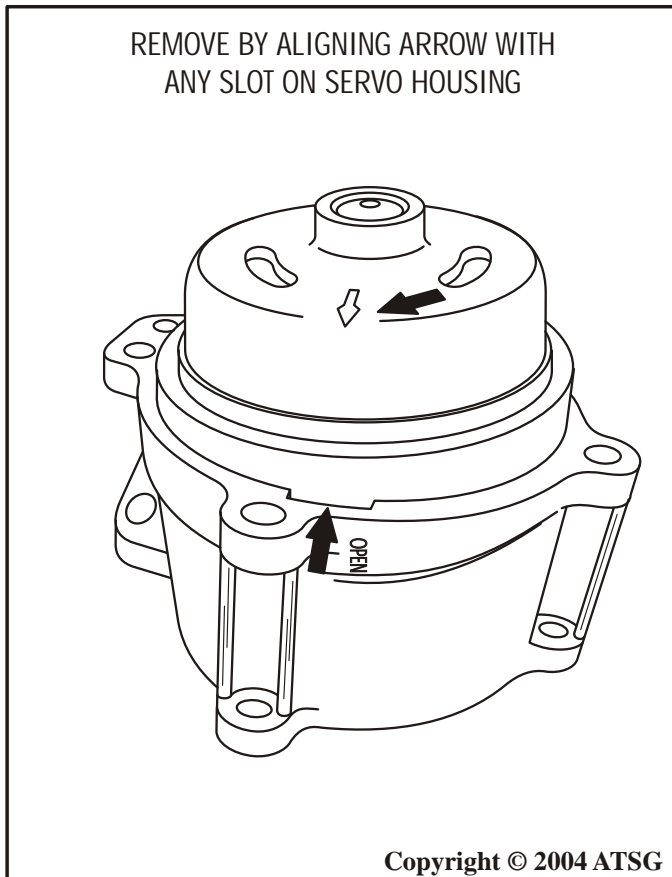

Figure 112

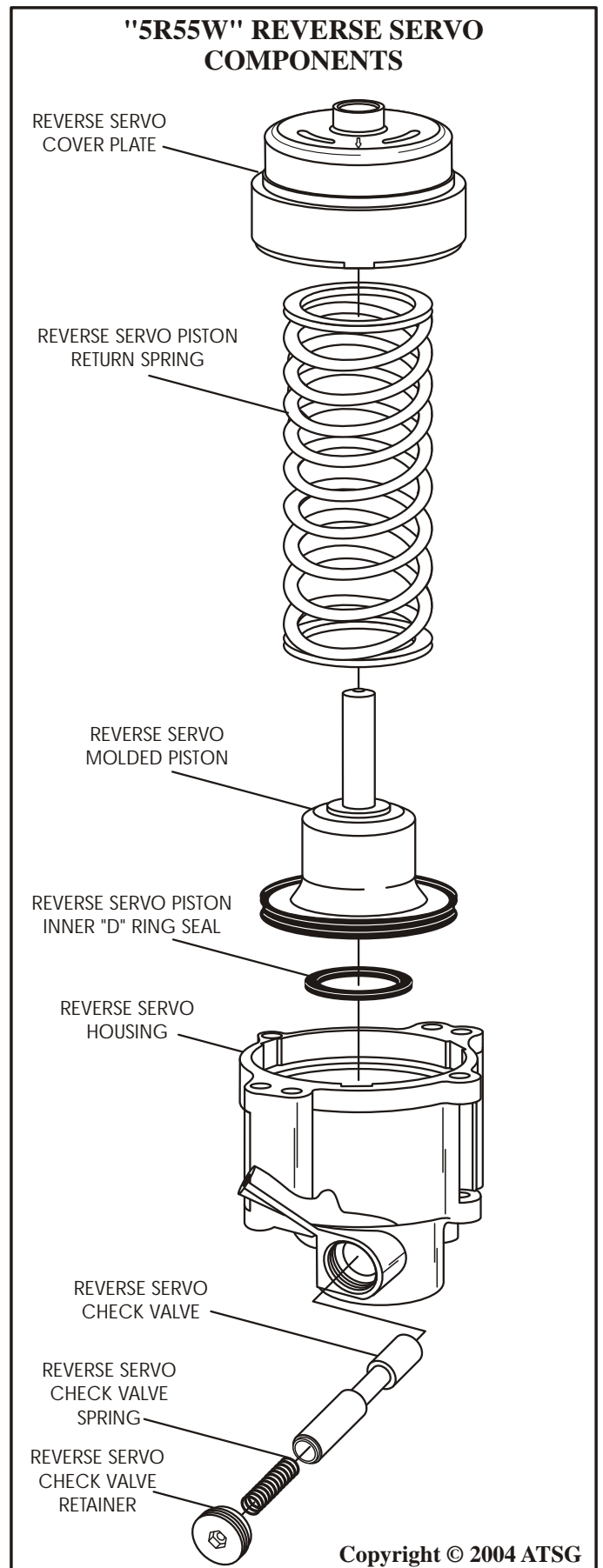

Figure 113

REVERSE SERVO ASSEMBLY (Cont'd)

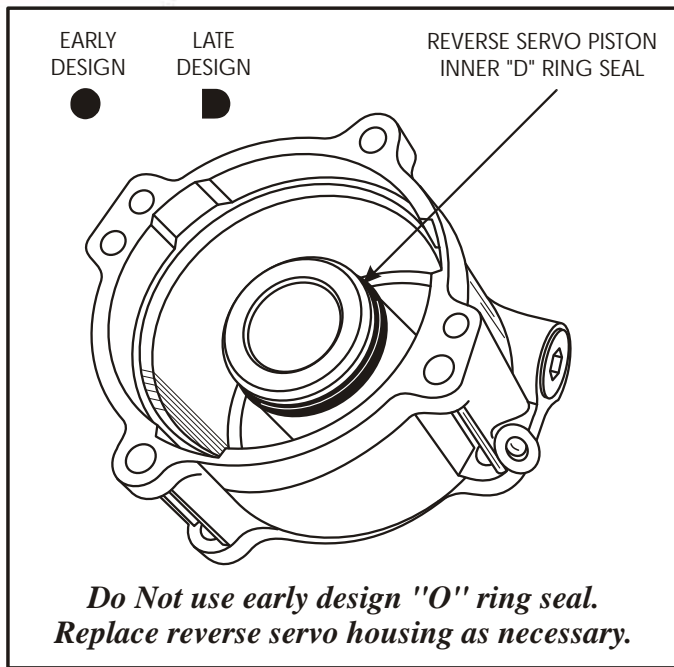

Figure 114

7. Install new reverse servo piston inner "D" ring seal into the groove in reverse servo housing, as shown in Figure 114, and lubricate with a small amount of Trans-Jel®.

Note: If the original seal was an "O" ring seal (Early Design), replace the reverse servo housing and use the "D" ring seal. Refer to Figure 114 for the cross section.

"Do Not" install a "D" ring seal into reverse servo housing designed for the "O" ring seal.

8. Lubricate the reverse servo check valve with Mercon® V, and install in housing, as shown in Figure 115, followed by the spring and the retainer.

9. Lubricate the reverse servo piston with a small amount of Trans-Jel®, and install into reverse servo housing, as shown in Figure 115.

Continued on Page 70

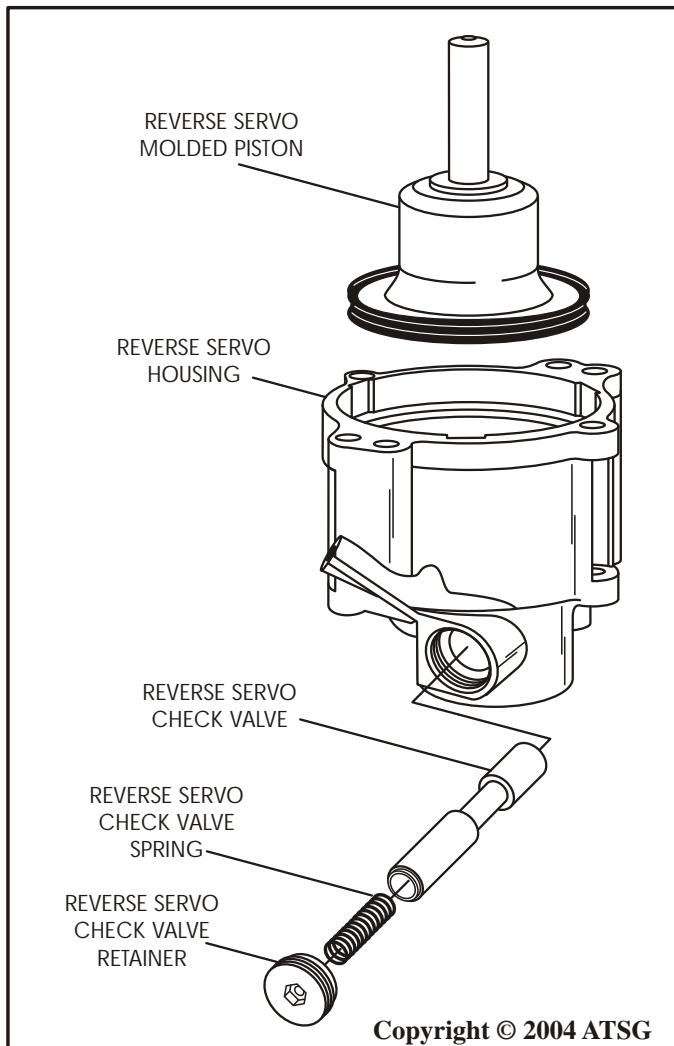

Figure 115

REVERSE SERVO ASSEMBLY (Cont'd)

10. Install the reverse servo piston return spring in reverse servo housing (See Figure 116).
11. Install the reverse servo cover plate over the return spring, compress the return spring with the cover plate and rotate the tabs into position in the slot, as shown in Figure 117.
12. **Caution:** *The arrow on the cover plate must be aligned evenly between any two slots on the reverse servo housing (See Figure 118).*
13. Set the completed reverse servo assembly aside for the final assembly process.

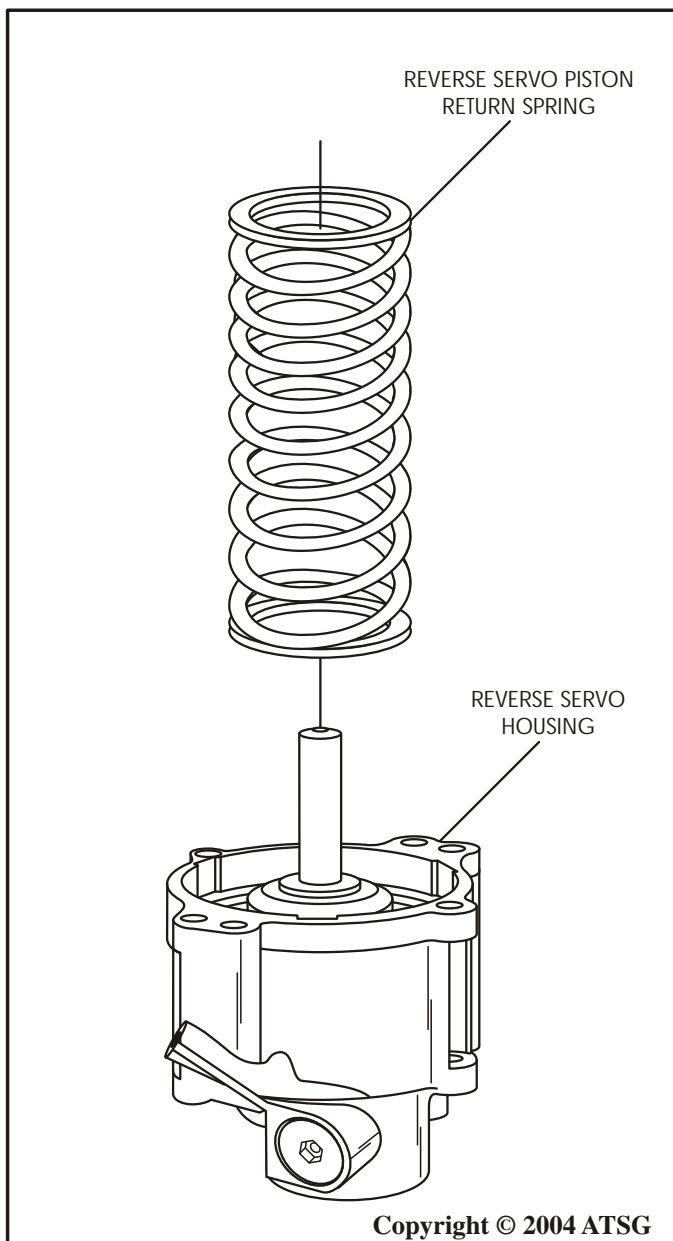

Figure 116

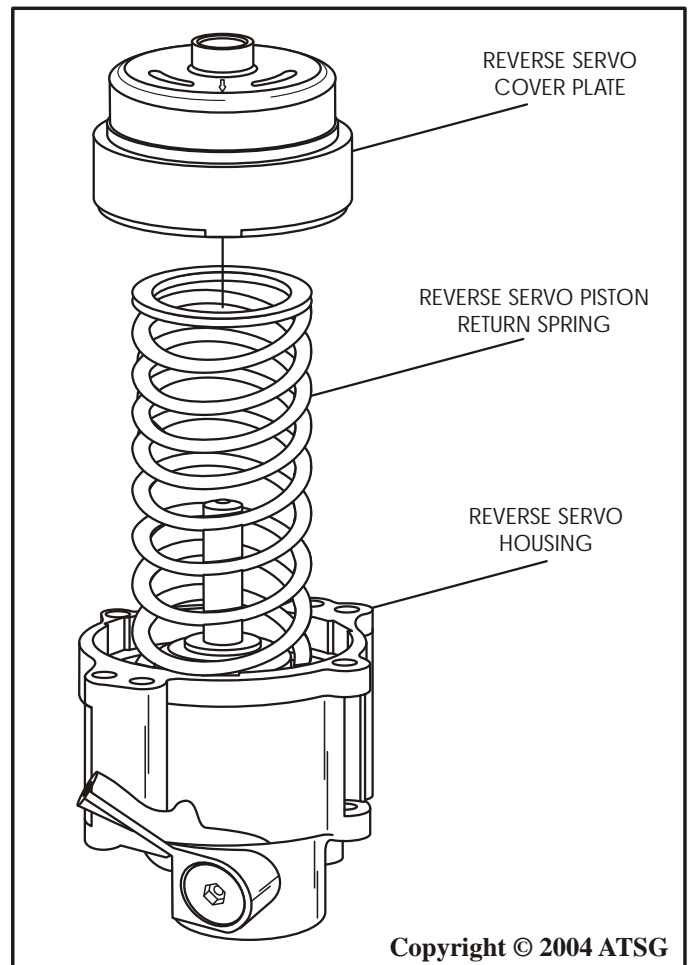

Figure 117

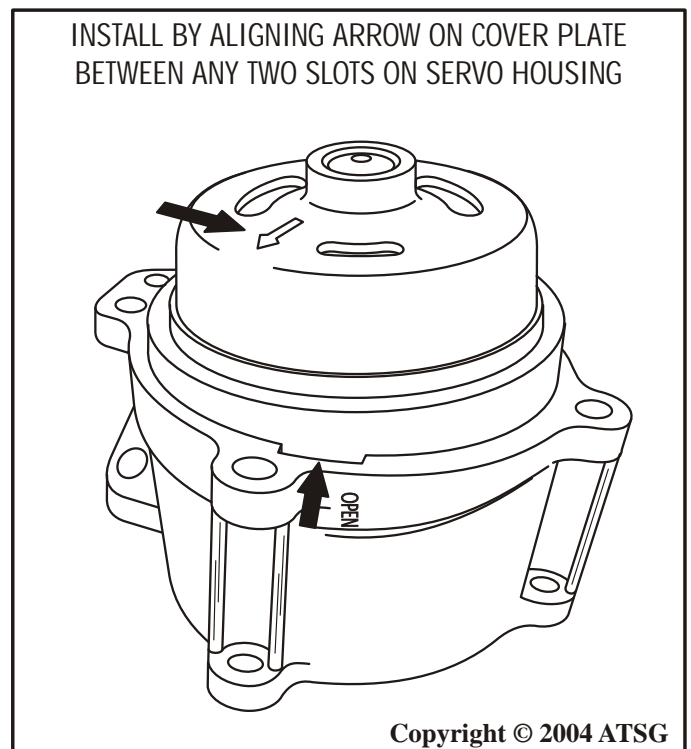

Figure 118

A VERY HEARTY "THANK YOU" TO LEON AUTRY OF
A & REDS TRANSMISSION PARTS
FOR SUPPLYING US WITH THE TRANSMISSION THAT MADE

A & REDS TRANSMISSION PARTS

PLEASE FEEL FREE TO CALL TODAY
1 800 835-1007

WE HAVE WHAT YOU NEED FOR
"ALL" YOUR TRANSMISSION NEEDS!

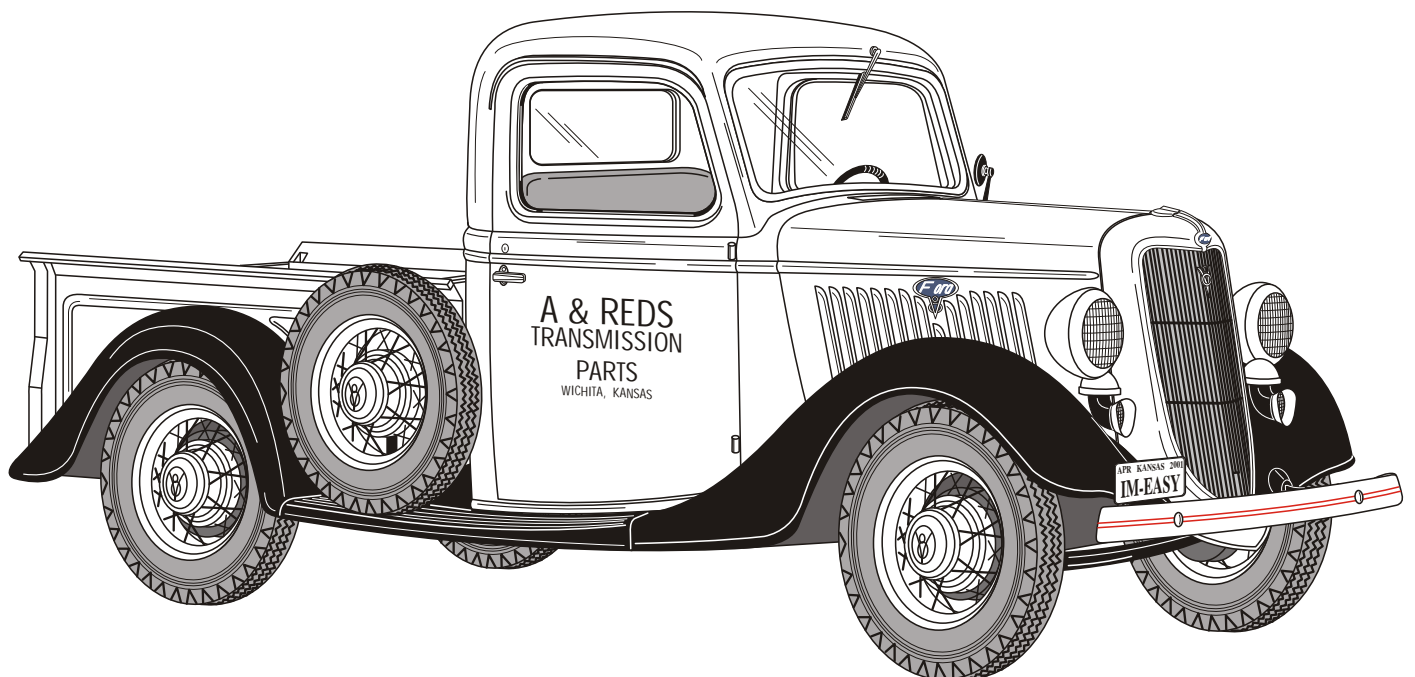

Copyright © 2004 ATSG

SOLENOID BODY ASSEMBLY "DIFFERNCES"

The solenoid bodies are different between the 5R55W/S and the 5R55N transmissions, and they **"Will Not"** interchange. The solenoid body differences and how to identify between the two, are shown in Figure 119 below.

Extra care here when selecting replacement parts, including the solenoid body gasket, will eliminate some of the troublesome problems that may be encountered after installation.

Continued in Page 73

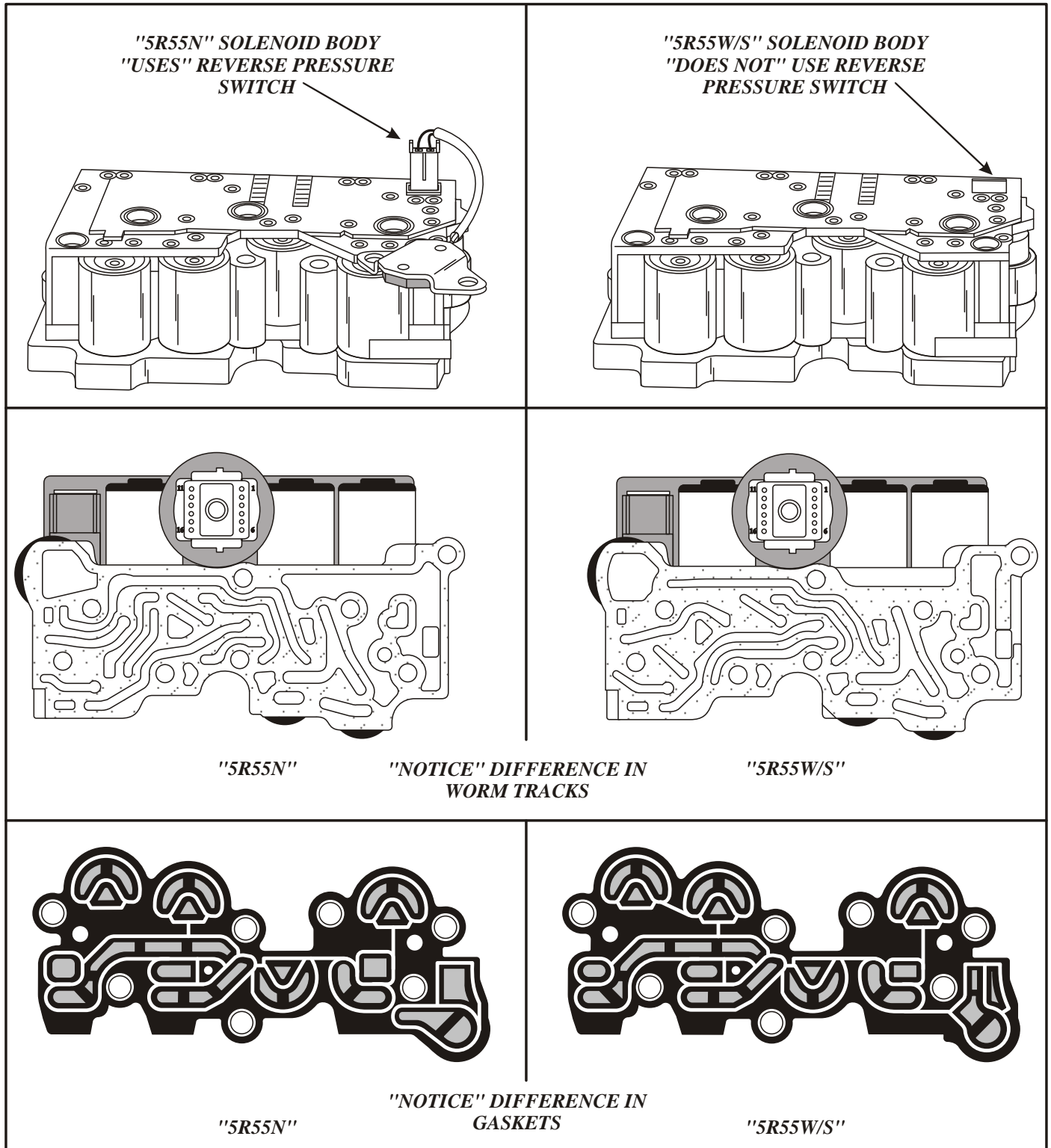

Figure 119

SOLENOID BODY ASSEMBLY

1. The solenoid body is serviced as a complete assembly only, from Ford Motor Company, however the aftermarket gasket sets do come with a new gasket and "O" rings.
2. Remove the worm track plate by prying back the locking tabs (See Figure 121).
3. Remove and discard the solenoid body to worm track plate gasket (See Figure 121).
4. Remove and discard the two solenoid body to case "O" rings, as shown in Figure 121.
5. Ensure that you have the proper gasket for the 5R55W/S, as shown in Figure 120. Refer to Figure 119 for the differences.
6. Install the new solenoid body to worm track plate gasket over the dowels on the solenoid body, as shown in Figure 121.
7. Install the worm track plate over the dowels on the solenoid body, as shown in Figure 121, and snap into position.
8. Install two new solenoid body to case "O" ring seals, as shown in Figure 121.
9. Set the completed solenoid body aside for the final assembly process (See Figure 122).

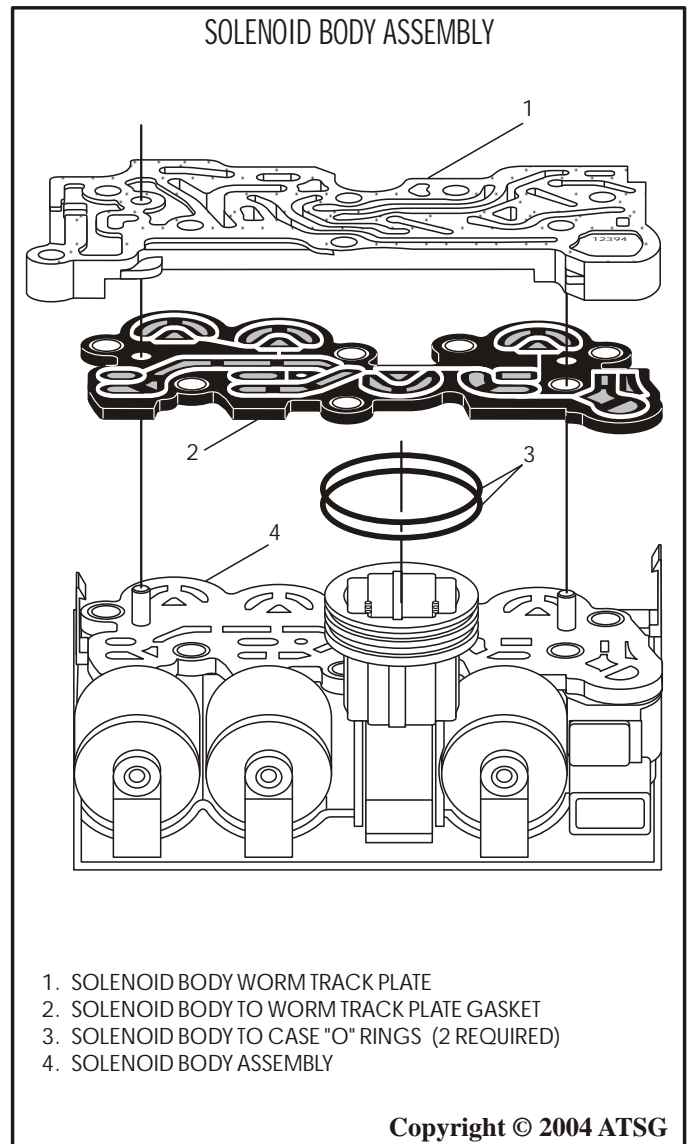

Figure 121

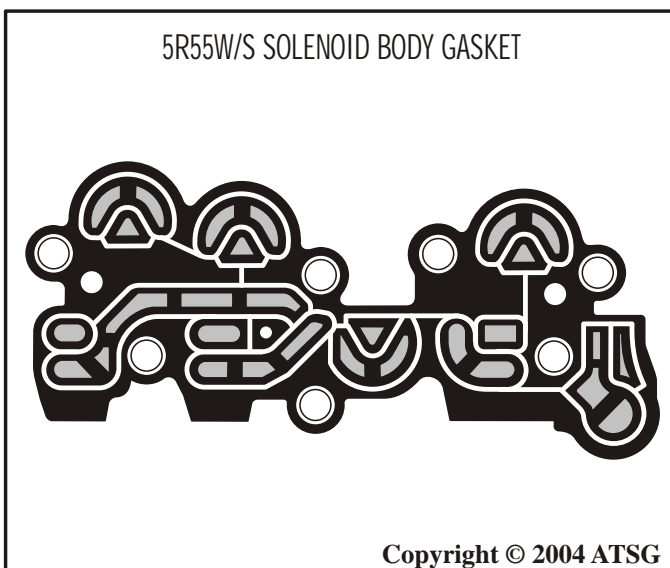

Figure 120

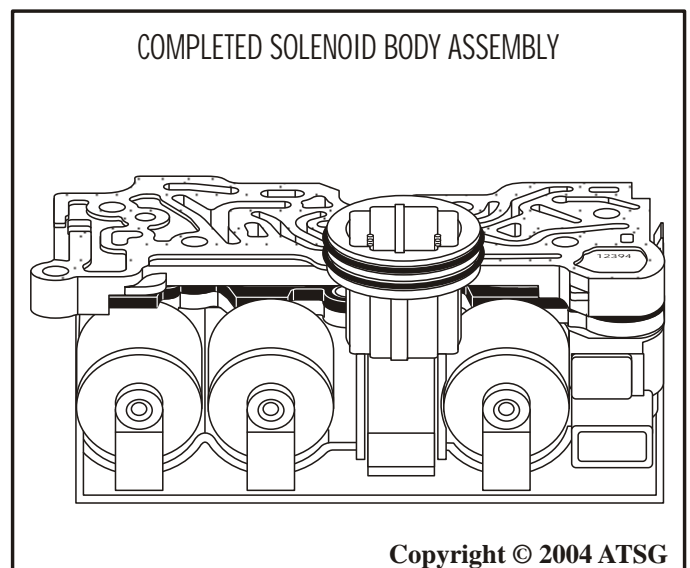

Figure 122

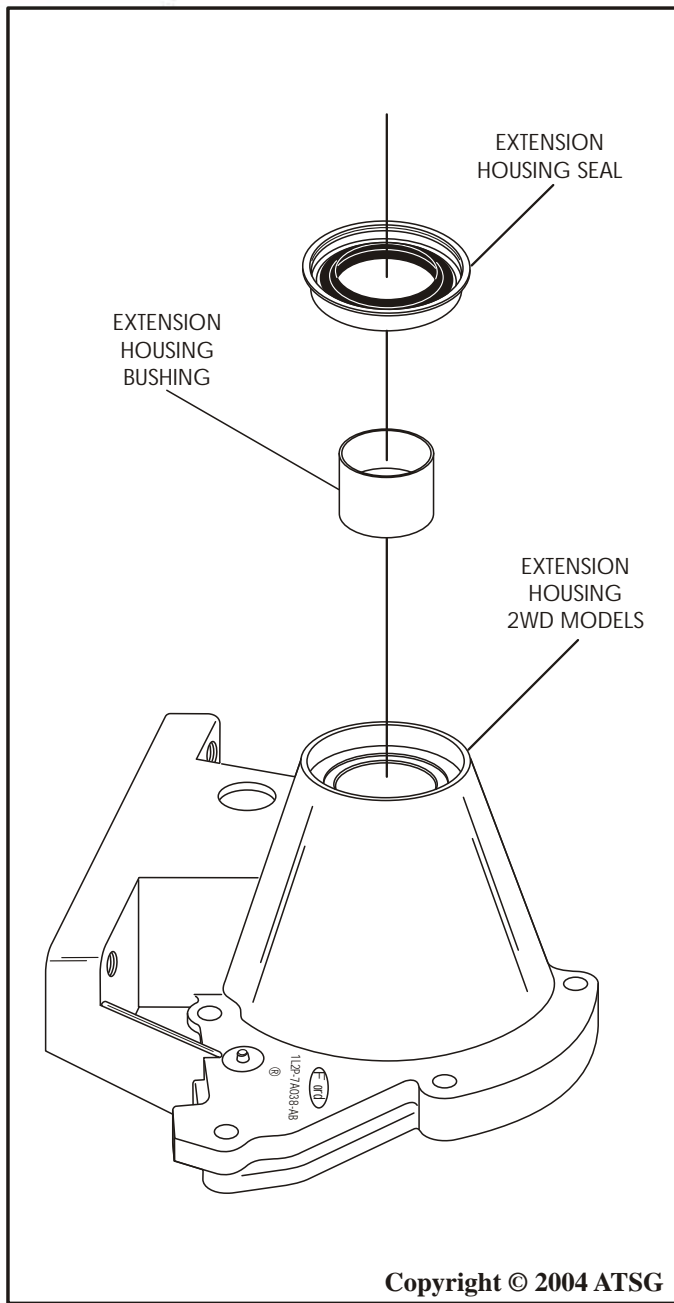

Figure 123

Copyright © 2004 ATSG

EXTENSION/4WD ADAPTER HOUSING

1. Inspect the 2WD extension housing bushing for any wear and/or damage.
2. Replace the 2WD extension housing bushing as necessary, using the appropriate puller and bushing driver. Use Figure 123 as a guide.
3. Install a new extension housing yoke seal, as shown in Figure 123, using the appropriate seal driver.
4. If you have a 4WD, install new adapter housing seal, as shown in Figure 124, using the proper seal driver.
5. Turn the 2WD extension housing or the 4WD adapter housing over to install the park pawl components, as shown in Figure 125, as the procedure is the same for either model.
6. Install the parking pawl return spring onto the adapter housing, with the leg of the return spring in front of housing shoulder, as shown in Figure 126.
7. Install the parking pawl pivot pin through the center of return spring, as shown in Figure 127.
8. Install the parking pawl over the pivot pin and hook the return spring on the parking pawl, as shown in Figure 128.
9. Set the completed extension housing aside for the final assembly process.

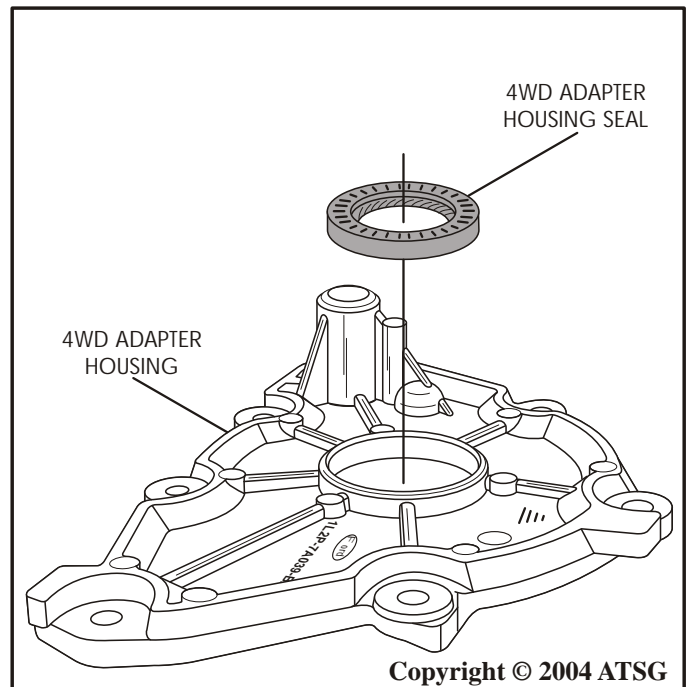

Figure 124

Copyright © 2004 ATSG

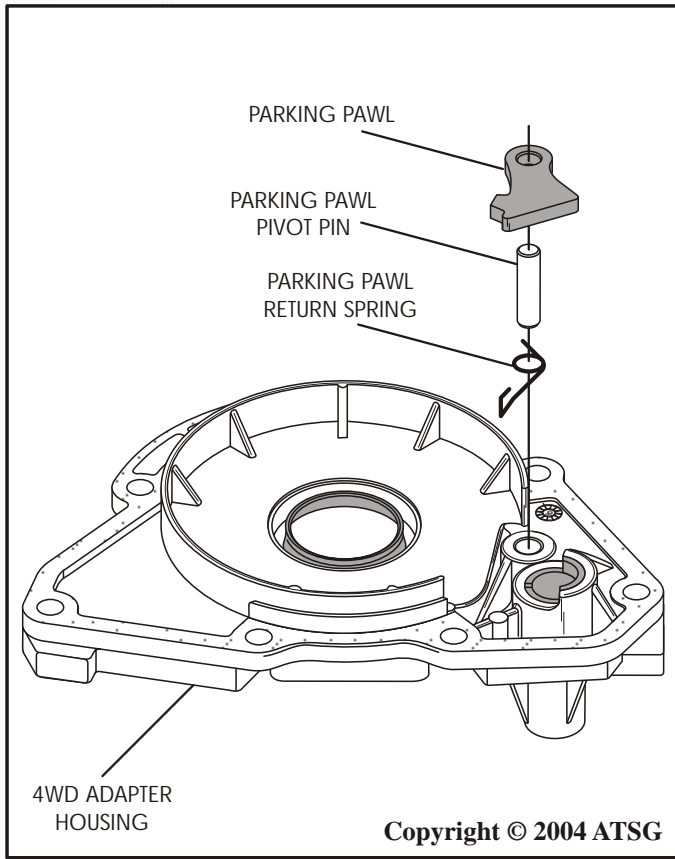

Figure 125

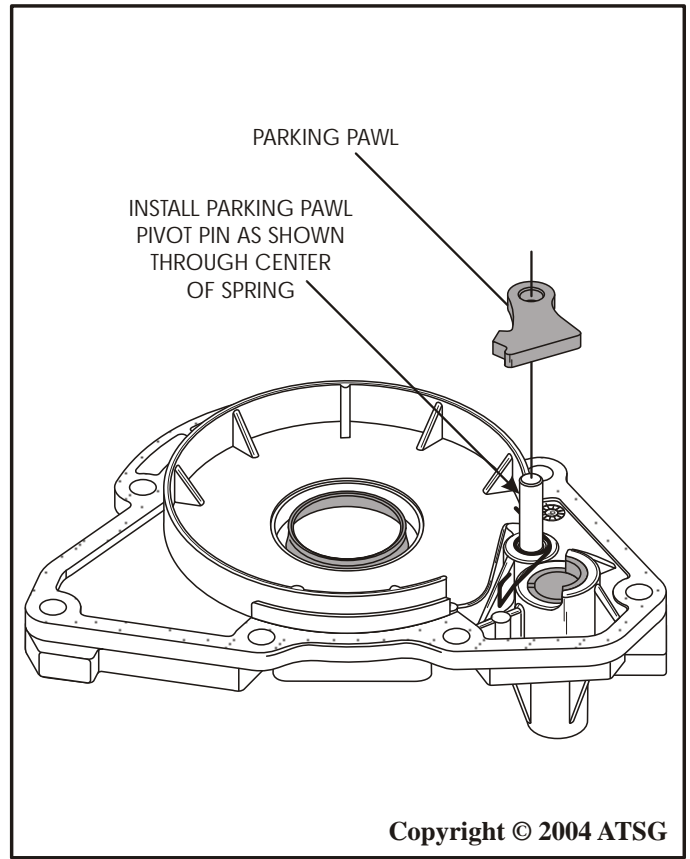

Figure 127

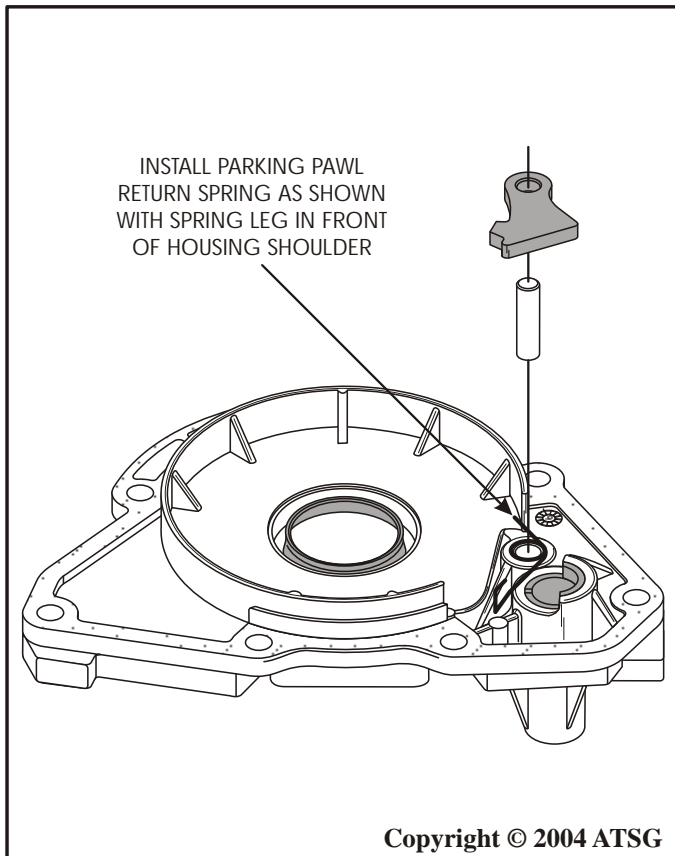

Figure 126

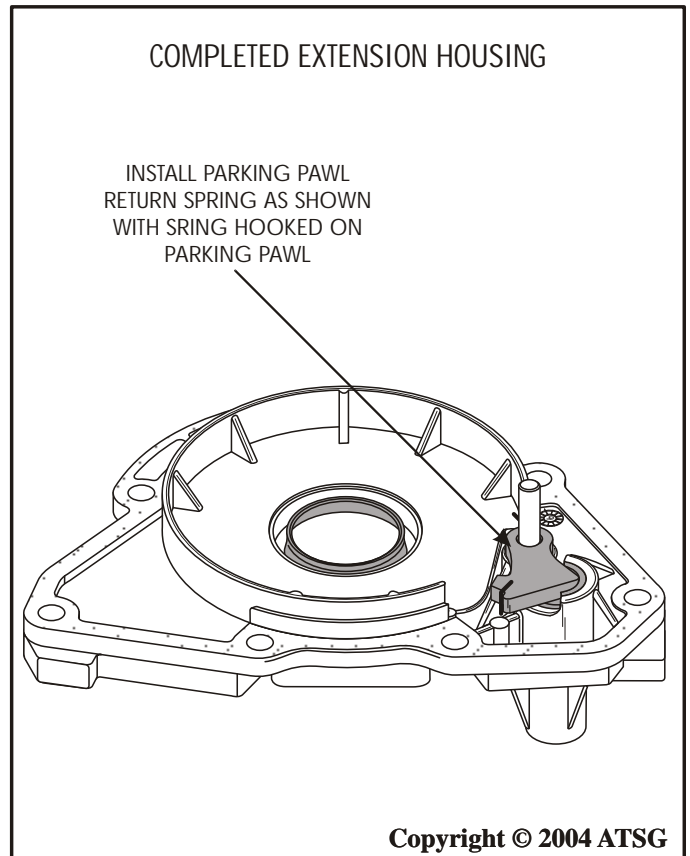

Figure 128

TRANSMISSION CASE ASSEMBLY

1. Inspect the transmission case thoroughly for wear, damaged surfaces, or stripped threads.
2. Inspect the rear case caged needle bearing and replace as necessary using the appropriate tools to remove and install (See Figure 131).

Note: *If replacement is necessary ensure that the sealing ring end of the bearing faces rear, as shown in Figure 131.*

3. Install new manual lever seal into case using the appropriate seal driver (See Figure 129).
4. There are two different styles of manual lever design, as shown in Figure 129.
5. Install the manual lever, inside detent lever and park rod assembly, manual lever retaining pin and torque nut to 48Nm (35 ft.lb.). Refer to Figure 130.

Note: *Do Not allow the wrench to strike the manual valve inner detent lever pin.*

6. Install the number 11 thrust washer into rear of case, as shown in Figure 131, and retain with a small amount of Trans-Jel®.

Continued on Page 78

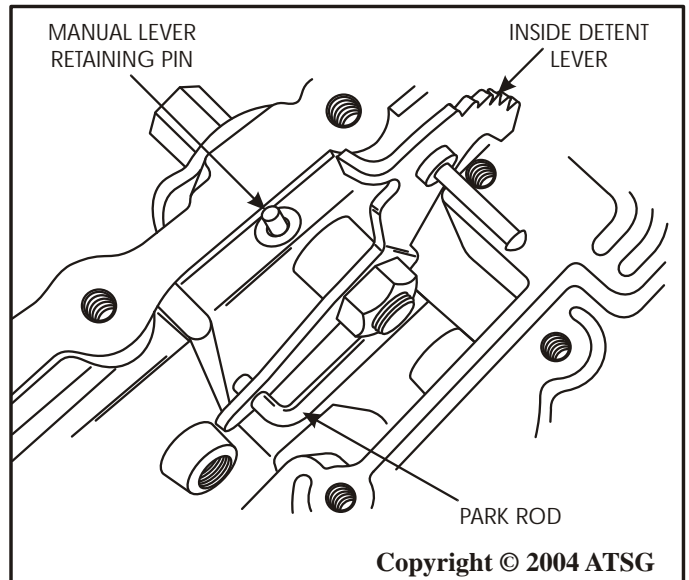

Copyright © 2004 ATSG

Figure 130

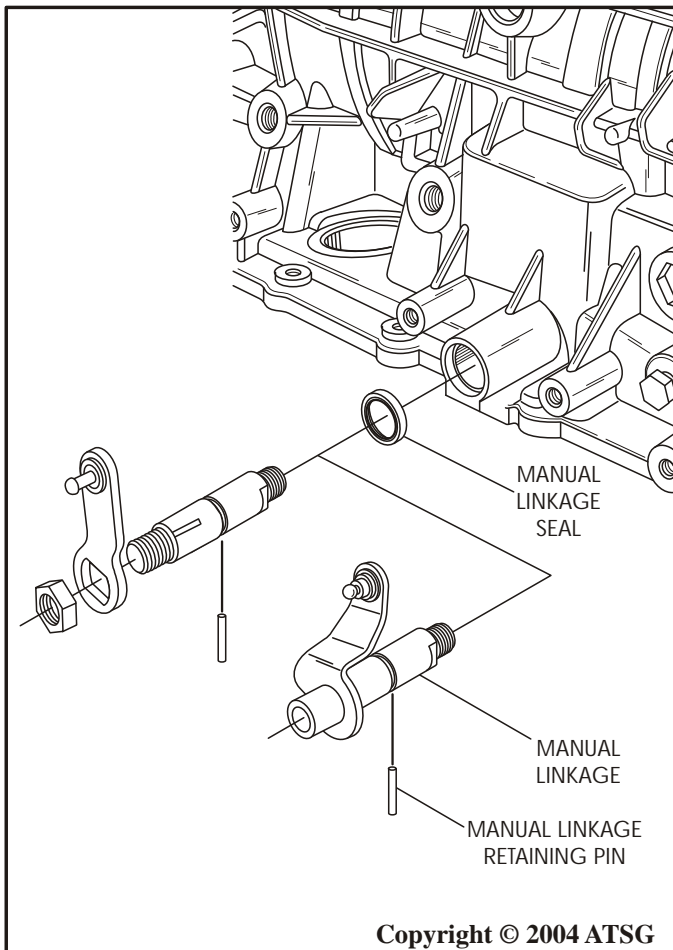

Copyright © 2004 ATSG

Figure 129

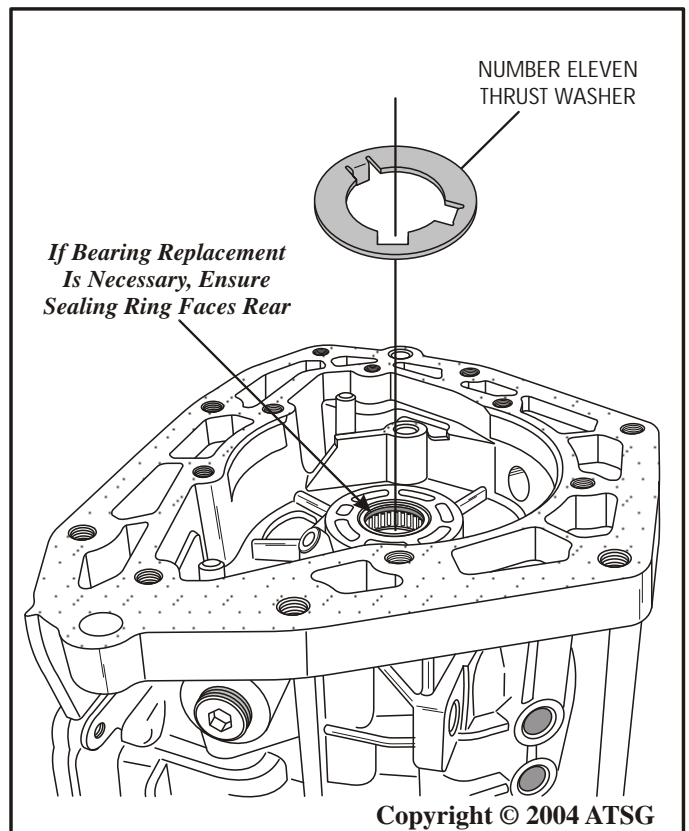

Copyright © 2004 ATSG

Figure 131

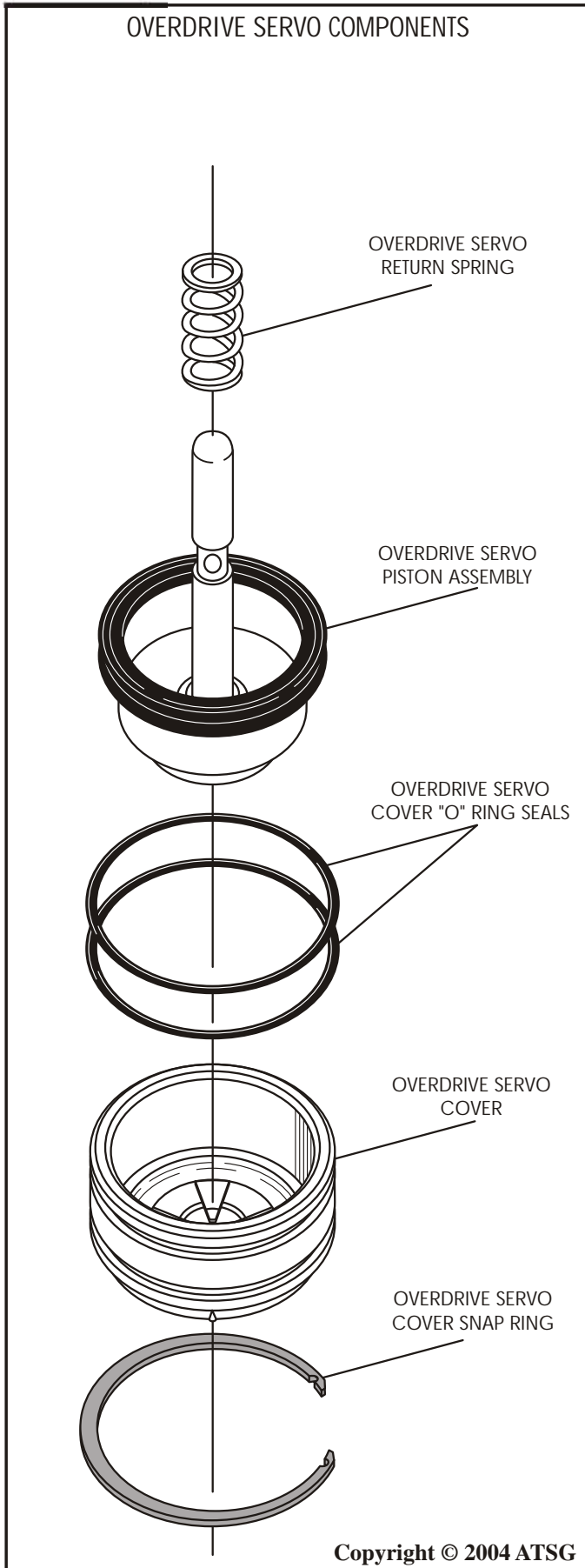

Figure 132

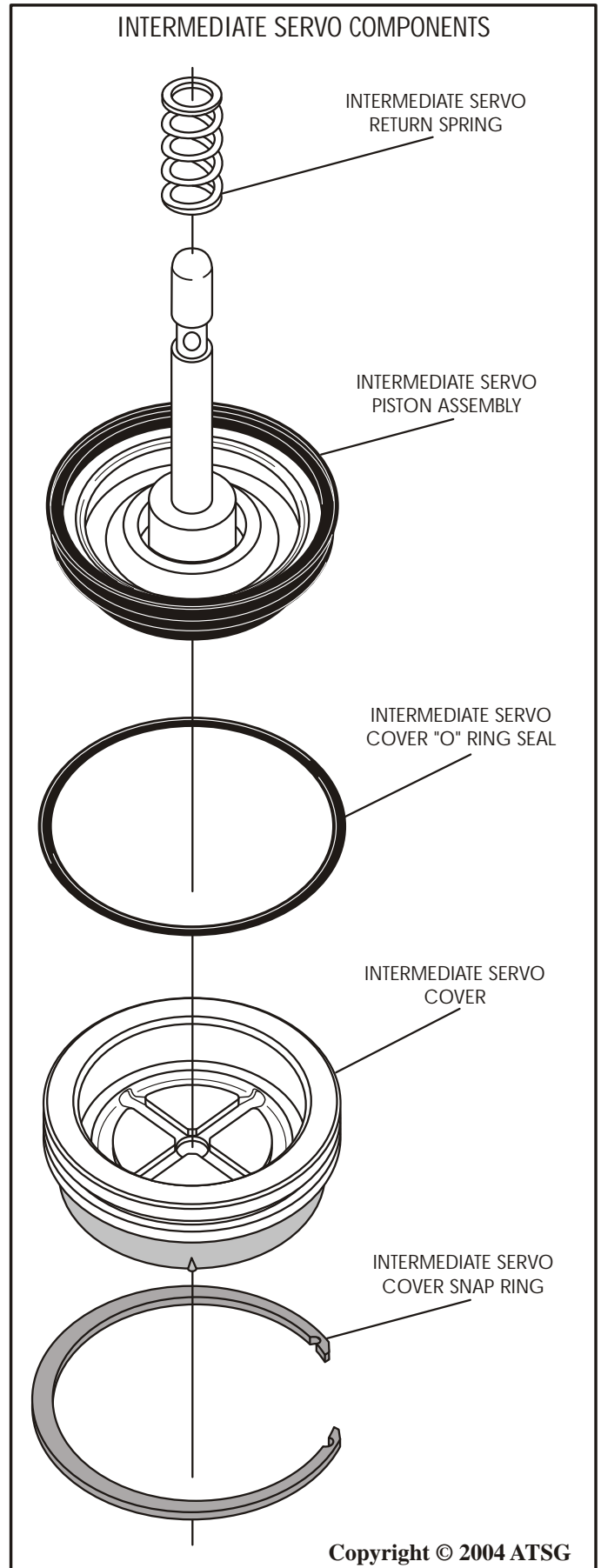

Figure 133

TRANSMISSION CASE ASSEMBLY (Cont'd)

7. Install the transmission case into the fixture and rotate so that pan surface is facing up, as shown in Figure 134.
8. Install new "O" ring seals into the overdrive servo cover grooves, as shown in Figure 132, and lubricate with small amount of Trans-Jel®.
9. Inspect the molded lip seal on the overdrive servo piston for any wear and/or damage and replace piston assembly as necessary.
10. Lubricate molded seal and the overdrive servo case bore with a small amount of Trans-Jel®, and install return spring on back side, as shown in Figure 132.
11. Install the overdrive servo cover assembly into the case bore, compress the return spring and install the snap ring (See Figure 134).
12. Install new "O" ring seals into the intermediate servo cover grooves, as shown in Figure 133, and lubricate with small amount of Trans-Jel®.
13. Inspect the molded lip seals on the intermediate servo piston for any wear and/or damage and replace piston assembly as necessary.
14. Lubricate molded seals and both intermediate servo cover bores with a small amount of Trans-Jel®.
15. Install the intermediate servo piston into the cover with a twisting motion, until it is fully seated (See Figure 133).
16. Install the servo return spring over the pin on the back side as shown in Figure 133.
17. Install the intermediate servo assembly into the case bore, compress the return spring and install the snap ring (See Figure 134).
18. With these two servo assemblies installed, you are now ready for the final assembly process.

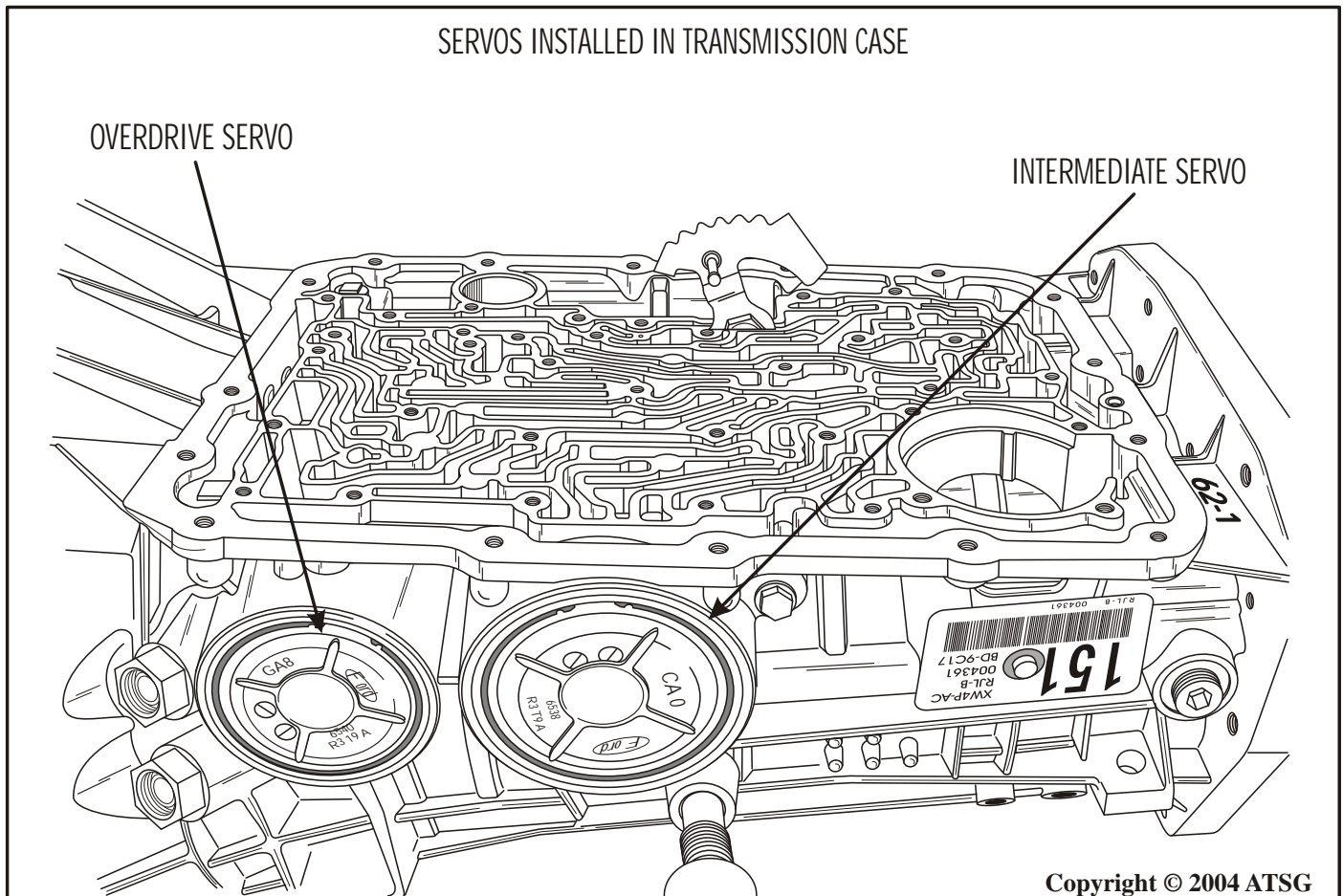

Figure 134

FINAL TRANSMISSION ASSEMBLY

INTERNAL COMPONENTS

1. Rotate transmission in fixture so that rear of the case is facing up, as shown in Figure 135.
2. Ensure that the number 11 thrust washer is still in place, as shown in Figure 135.
3. Install the park gear and output shaft, as shown in Figure 135.
4. Install the extension housing gasket, as shown in Figure 136, and retain with a small amount of Trans-Jel®.

Continued on Page 80

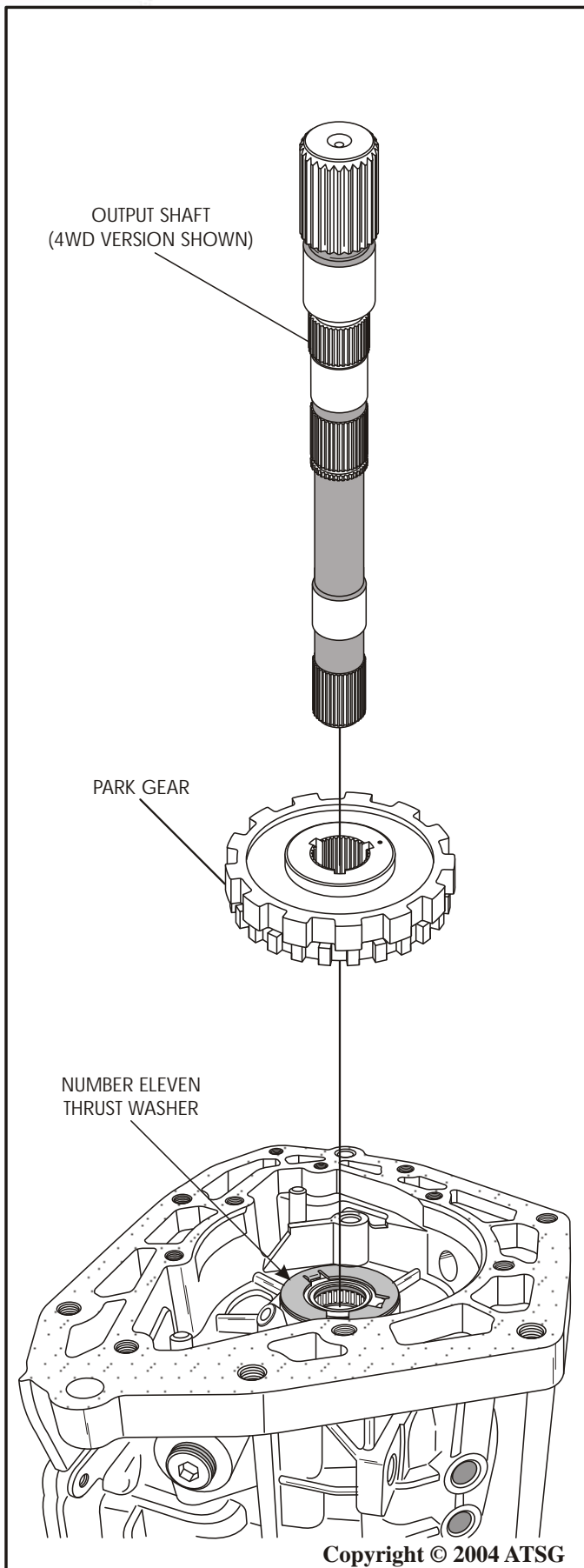

Figure 135

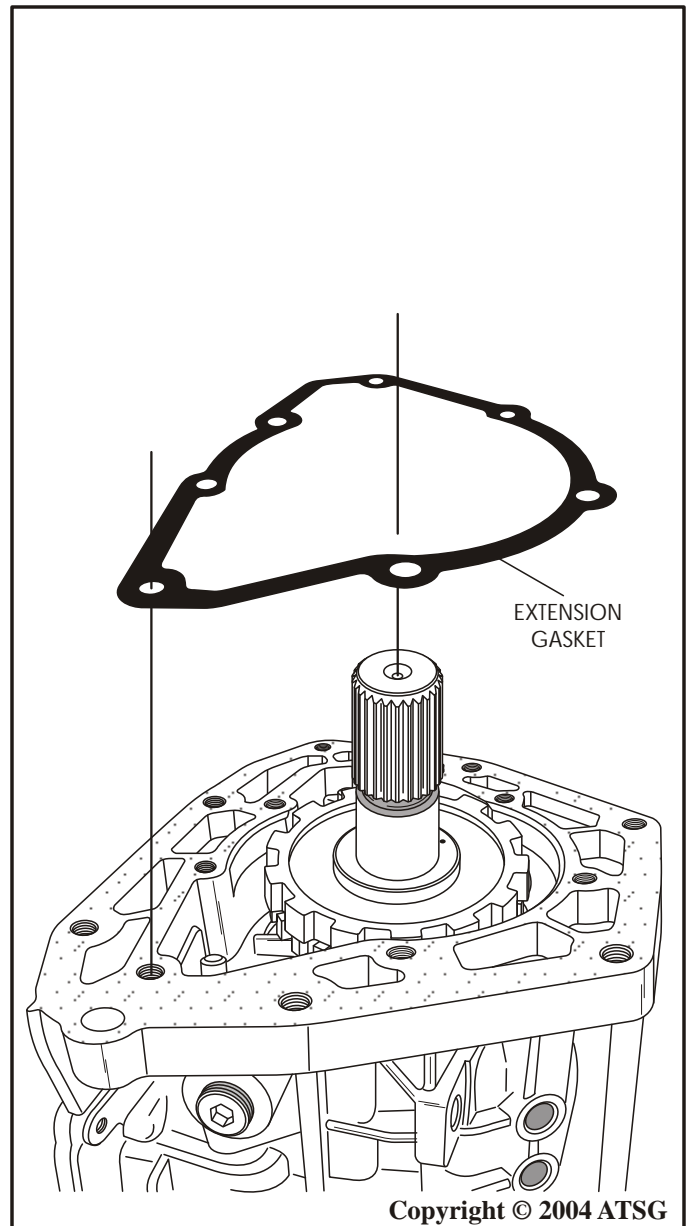

Figure 136

INTERNAL COMPONENTS (Cont'd)

5. Install the preassembled 4WD adapter housing ensuring that the parking pawl is engaged on the park rod properly (See Figure 137).
6. Install the seven 4WD adapter housing bolts and torque bolts to 39 N•m (29 ft.lb.), as shown in Figure 138.

7. Install the temporary holding strap, as shown in Figure 139, to retain the output shaft in the transmission until snap ring is installed.

Continued on Page 81

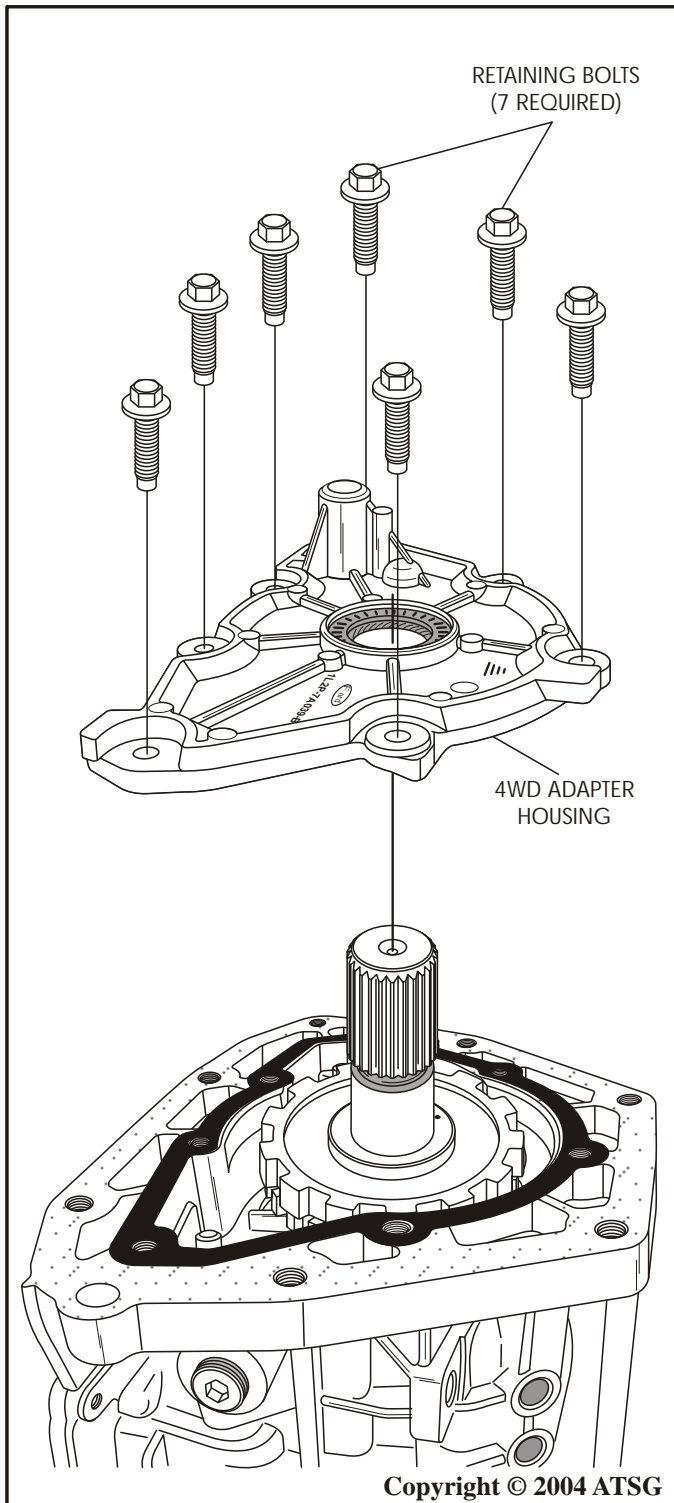

Figure 137

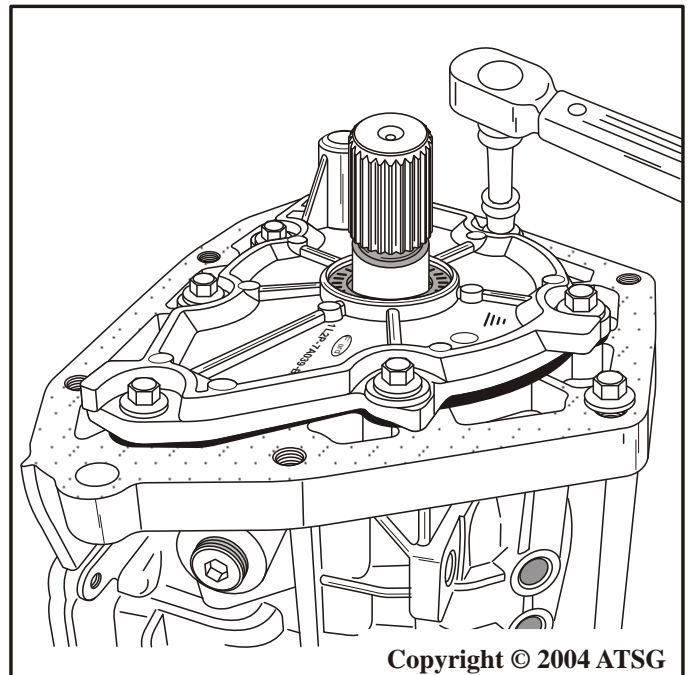

Figure 138

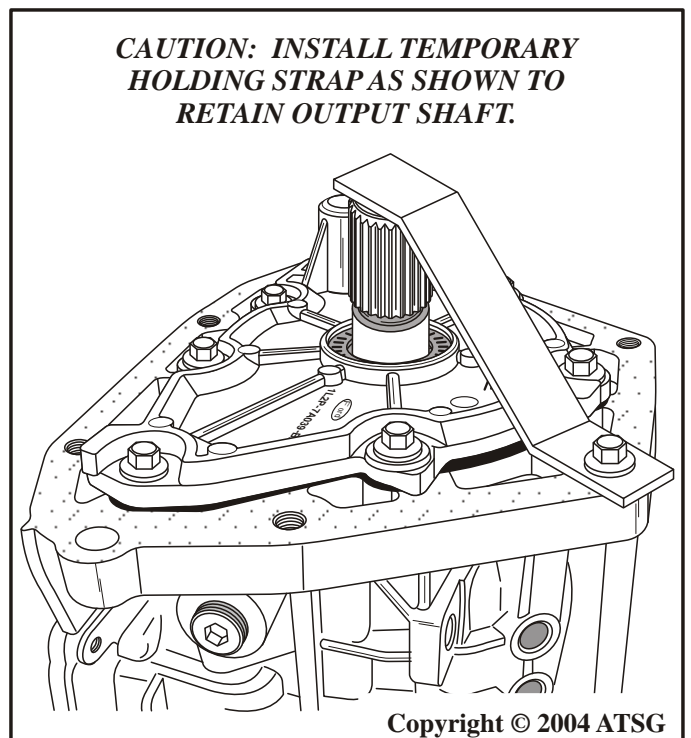

Figure 139

INTERNAL COMPONENTS (Cont'd)

8. Rotate transmission in fixture so that front of case is facing up, as shown in Figure 140.
9. Install the reverse band into transmission, as shown in Figure 140, ensuring that it engages on the band anchor lugs in the case.
10. Compress the reverse band enough to engage the reverse band louver into the notches in the reverse band.
11. Install reverse drum and low sprag assembly into the reverse band, as shown in Figure 140, by rotating in a clock-wise direction until it falls into position.
12. Install rear planetary ring gear thrust bearing (No. 10) into the case in the direction that is shown in Figure 140.
13. Install the pre-assembled rear planetary ring gear that has the seal ring with the notches in it, as shown in Figure 141, and ensure that it is fully seated against bearing.

Continued on Page 82

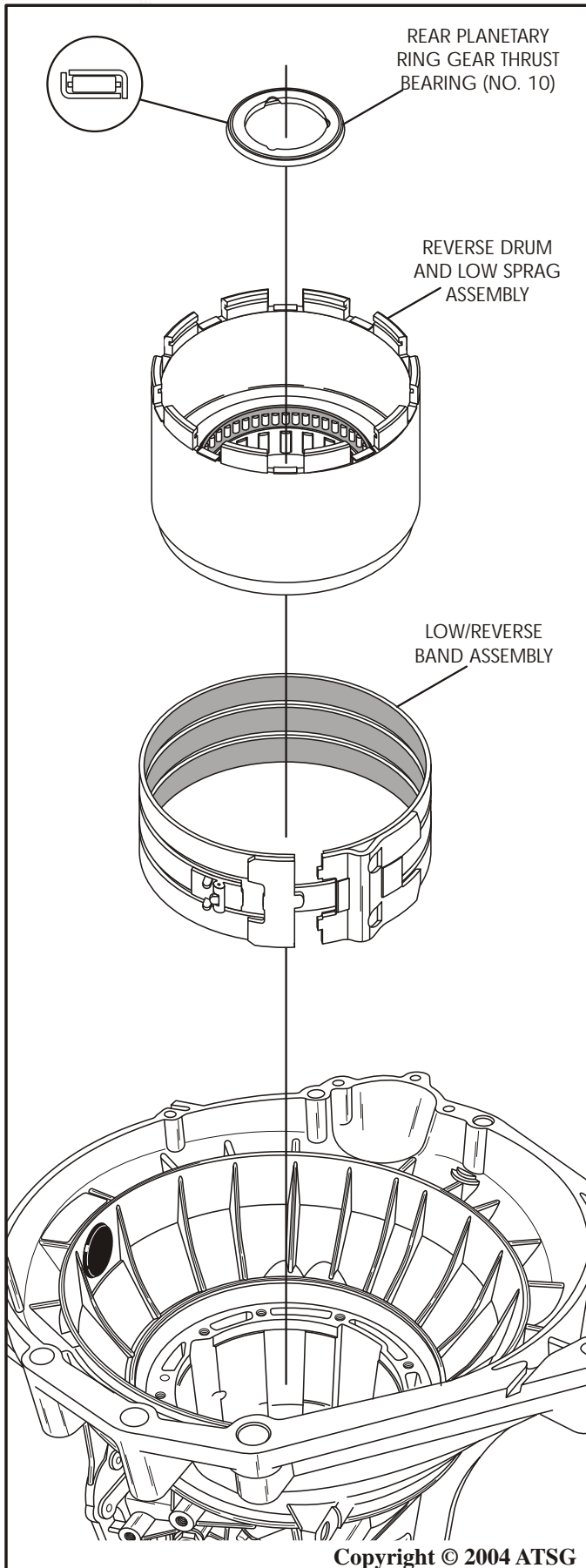

Figure 140

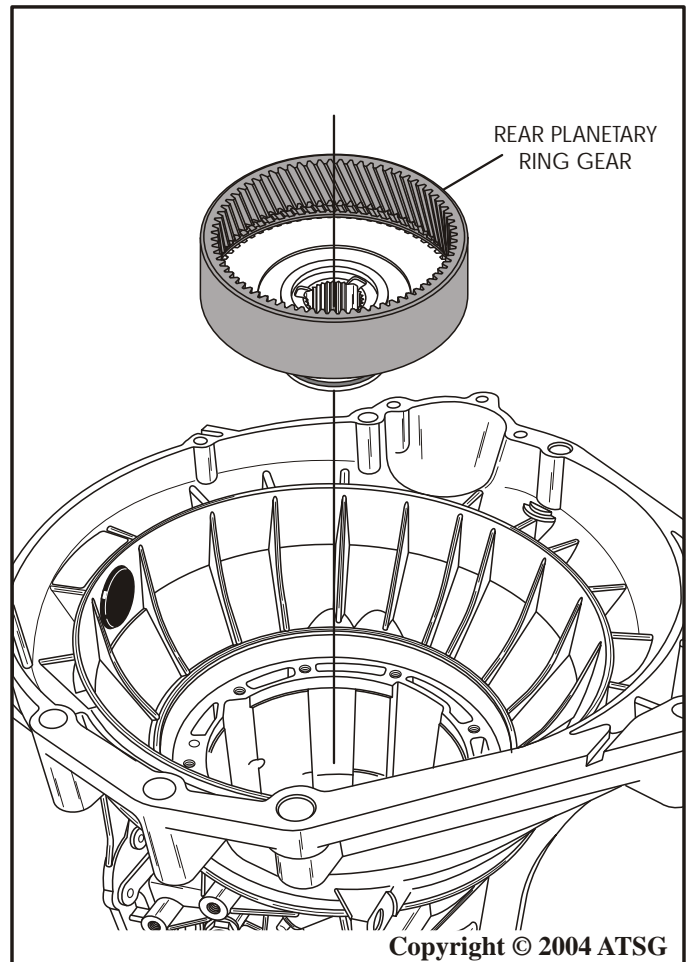

Figure 141

INTERNAL COMPONENTS (Cont'd)

14. Install a **new** output shaft snap ring onto output shaft, as shown in Figure 142, and ensure that it is fully seated.

Note: Ford Motor Company recommends a new snap ring in this location "every time", and after this ring is installed you may now remove the temporary strap.

15. Install the plastic rear lube dam into the ring gear in the direction shown in Figure 142.
16. Install the rear planetary thrust bearing (No. 9) on top of rear ring, in the direction shown in Figure 143, and retain with small amount of Trans-Jel®.
17. Install the rear planetary carrier assembly, as shown in Figure 143, by rotating into position until fully seated.
18. Install the rear planetary carrier snap ring into groove in the reverse drum and ensure that it is fully seated (See Figure 143).
Note: Reverse drum must be lifted up to install the snap ring.

19. Install the rear planetary thrust bearing (No. 8) on top of the rear planetary carrier, in direction shown in Figure 143, and retain with a small amount of Trans-Jel®.

Continued on Page 83

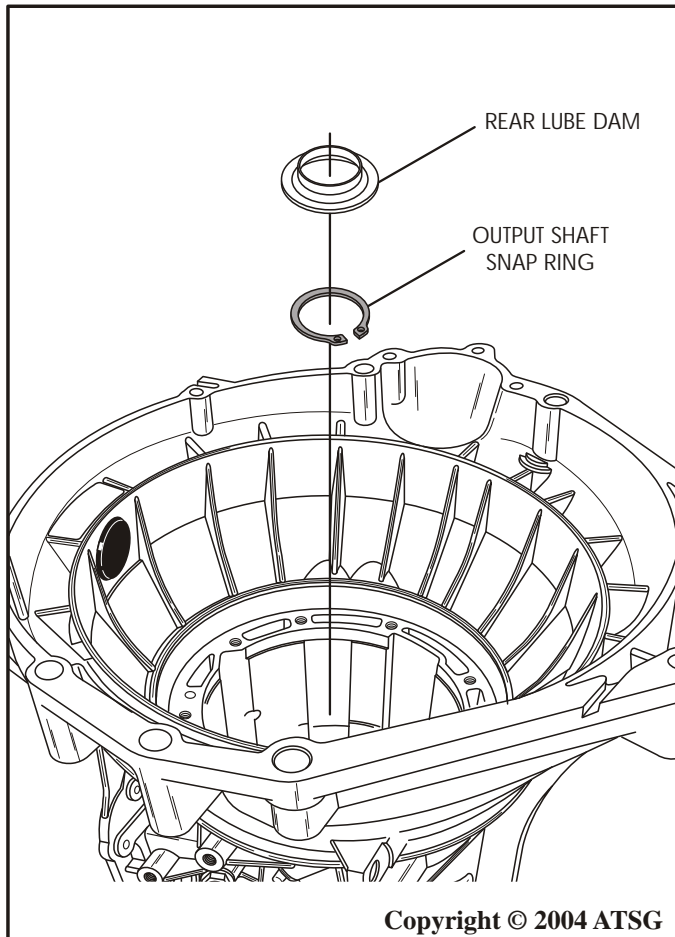

Figure 142

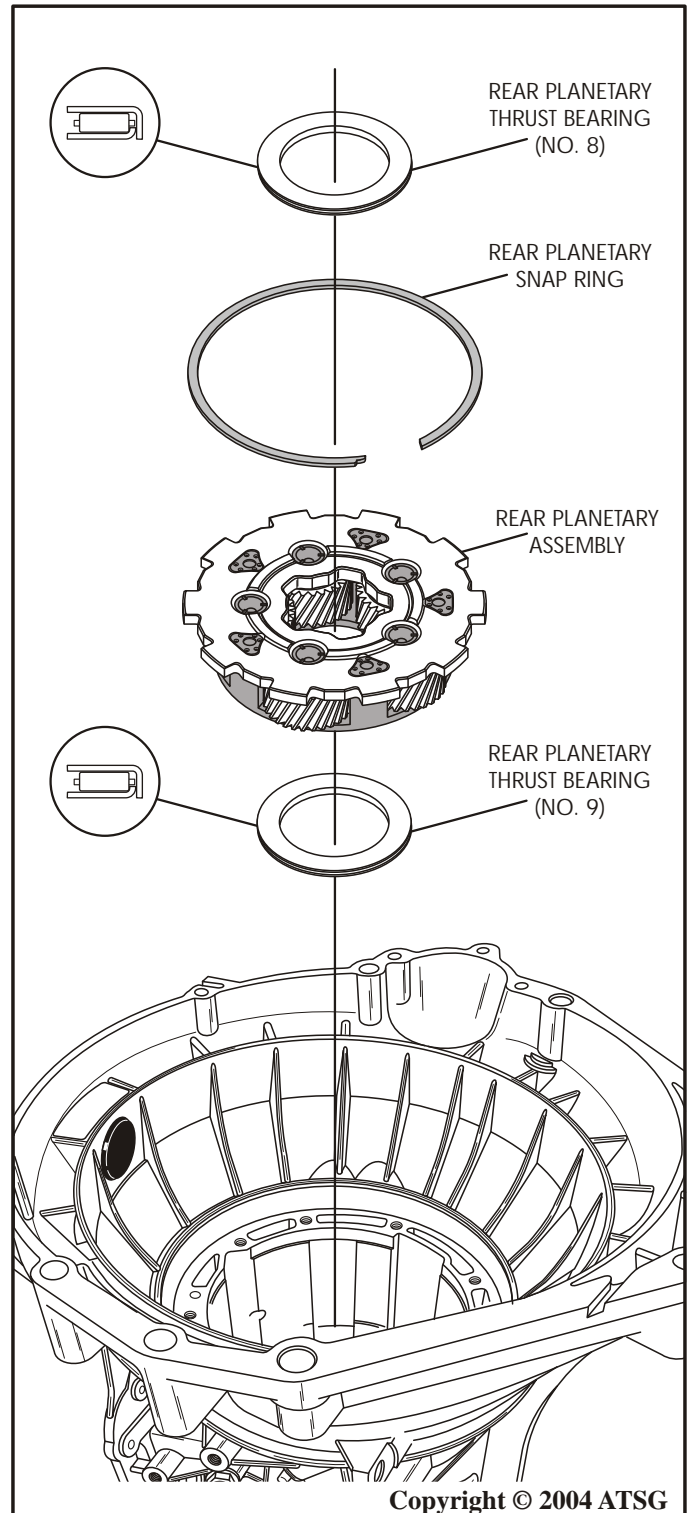

Figure 143

INTERNAL COMPONENTS (Cont'd)

20. Install the "Tall" low/reverse spacer on top of the No. 8 thrust bearing, in the direction shown in Figure 144.
21. Install the input sun gear and shell assembly, as shown in Figure 144.
22. Install the forward planetary carrier with the No. 6 thrust washer, as shown in Figure 145, by rotating into position.

Caution: *Ensure that snapped in thrust washer is still in position.*

23. Install forward planetary carrier thrust bearing (No. 7) in the direction shown in Figure 145, and retain with small amount of Trans-Jel®.
24. Install the forward ring gear and hub, as shown in Figure 145, by rotating into position.
25. Install forward clutch thrust washer (No. 6B), as shown in Figure 145.

Continued on Page 84

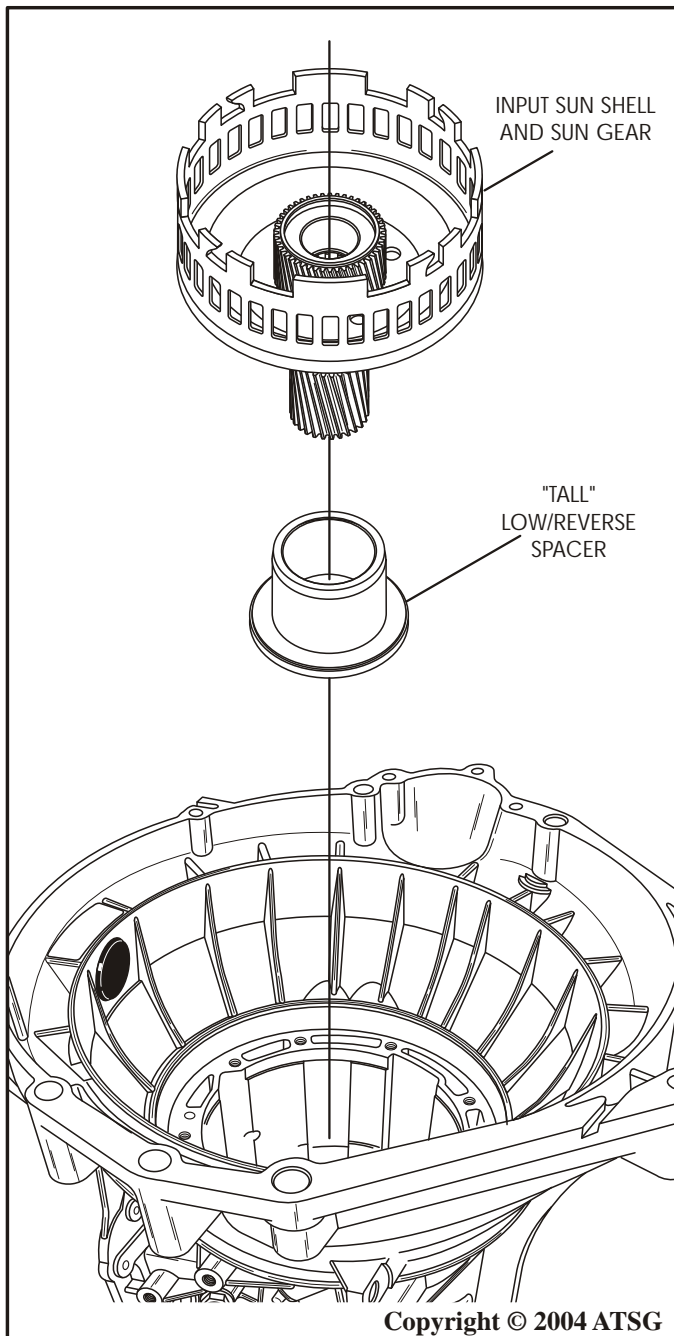

Figure 144

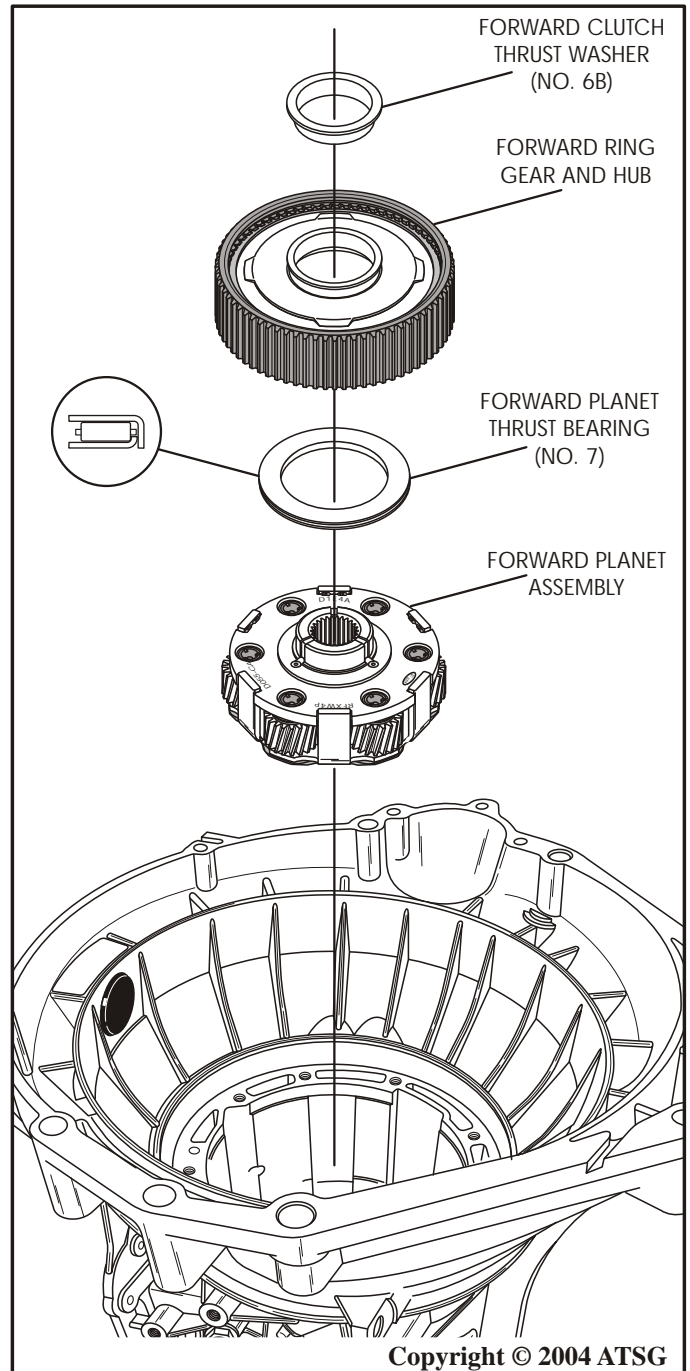

Figure 145

INTERNAL COMPONENTS (Cont'd)

26. Install forward clutch thrust bearing (No 6A) onto the back side of pre-assembled forward clutch drum, in direction shown in Figure 146, and retain with a small amount of Trans-Jel®.
27. Install forward clutch thrust bearing (No 5) on front side of forward clutch drum, in direction shown in Figure 146, and retain with a small amount of Trans-Jel®.
28. Install forward clutch housing, with bearings, as an assembly, as shown in Figure 146.
29. **Caution: The thrust bearing (No 4) that goes between direct clutch drum and center support is "Selective" and a measurement must be made before installation.**

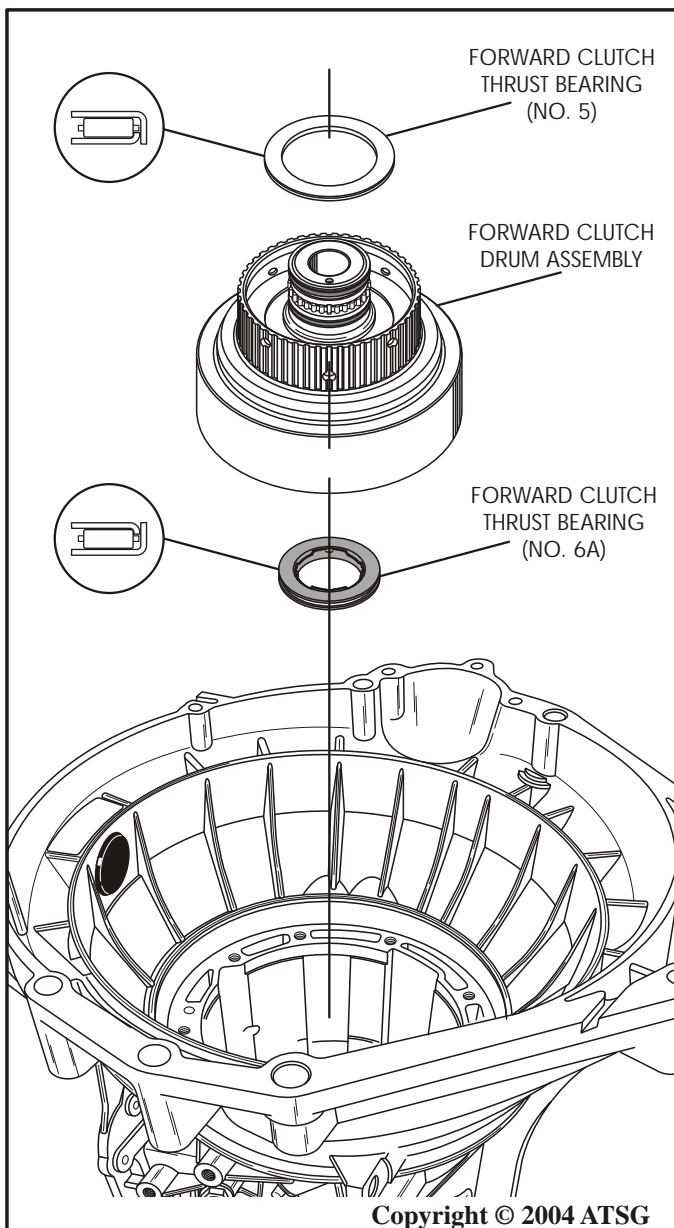

Figure 146

30. Assemble the selective bearing, direct clutch housing and center support, **on the bench**, as shown in Figure 147.
31. Measure with a dial caliper through the speed sensor hole down to the surface of the direct clutch housing, as shown in Figure 147, and record this as dimension "A".
32. After you have recorded the first measurement, install the pre-assembled direct clutch housing, as shown in Figure 148.
33. Install the number 4 thrust bearing in position on the direct clutch drum, in the direction that is shown in Figure 148.
34. Install the intermediate band into transmission and around the direct clutch housing, as shown in Figure 149.
35. Install the intermediate band struts on each side of the band **exactly** as shown in Figure 150.

Continued on Page 86

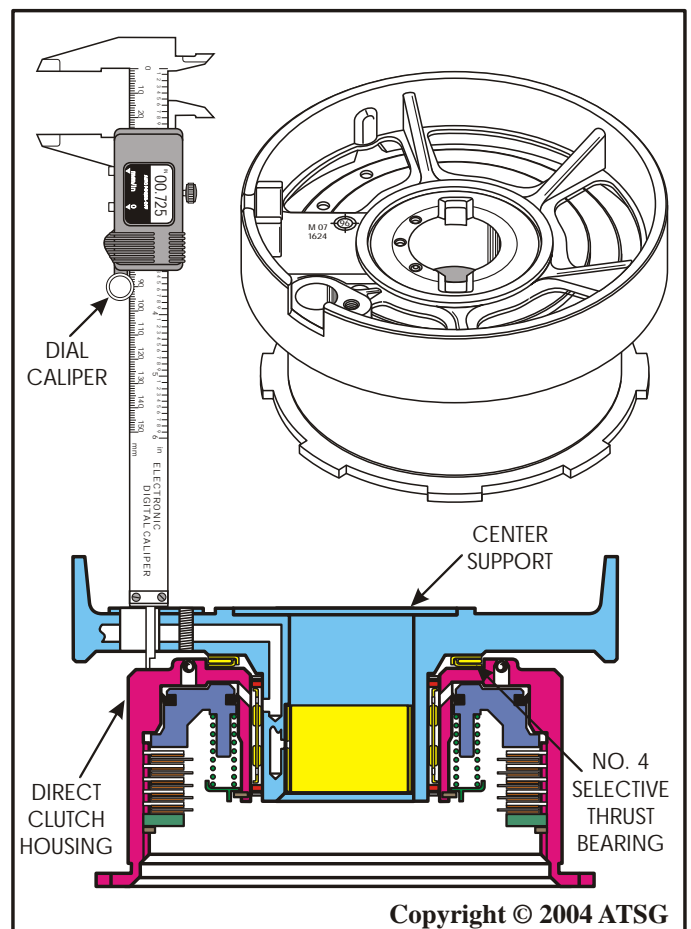

Figure 147

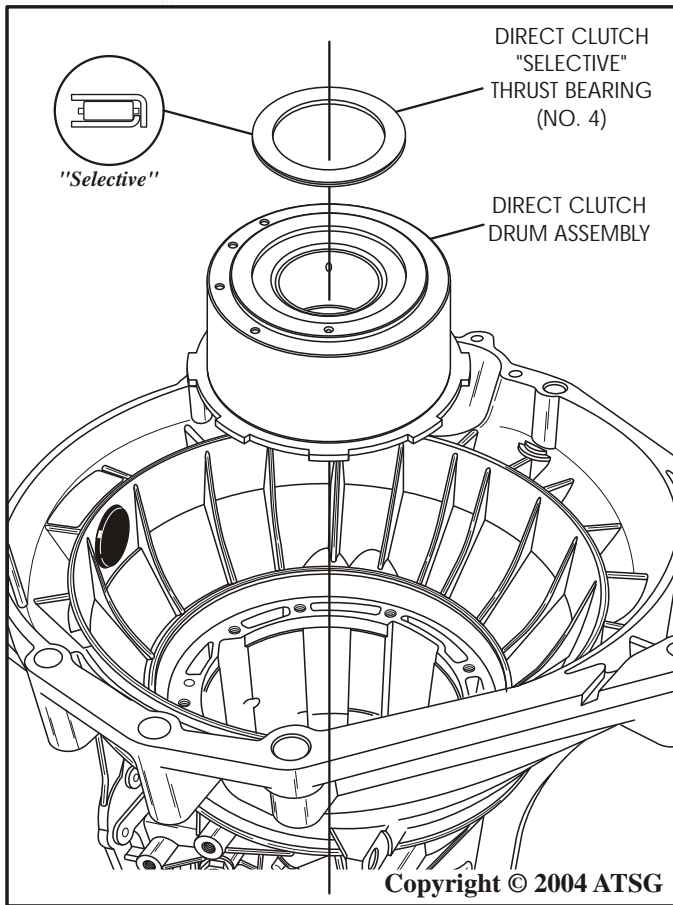

Figure 148

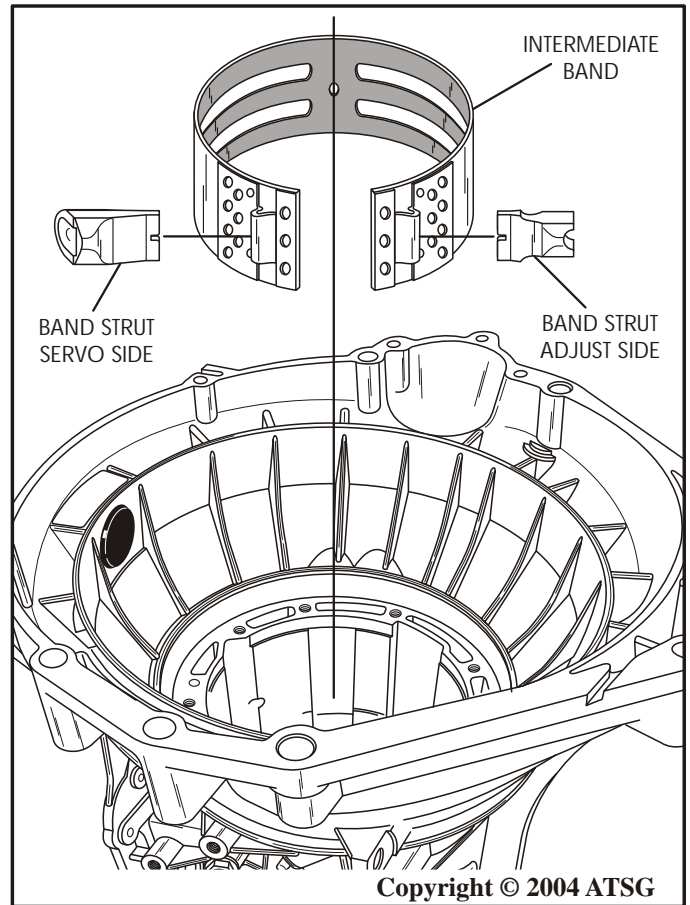

Figure 149

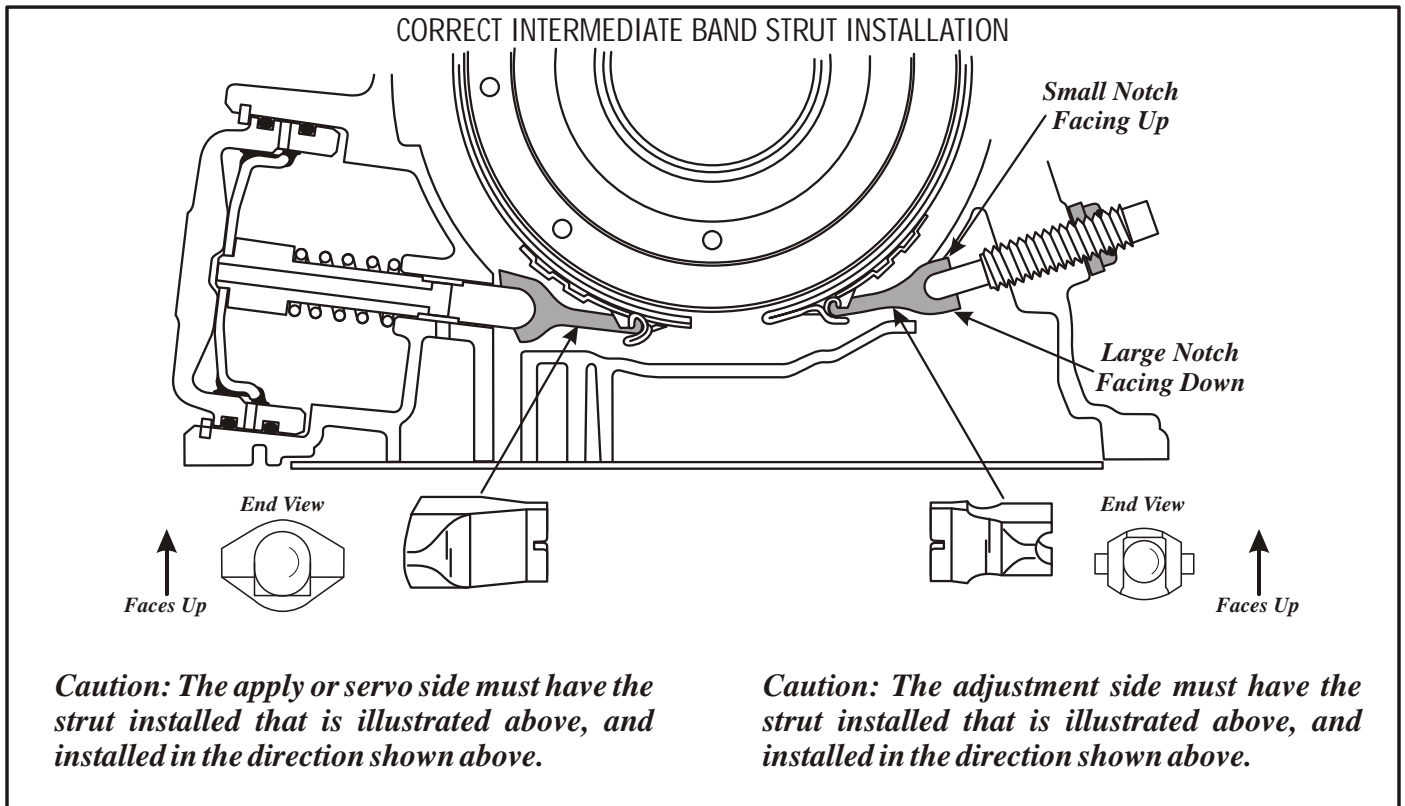

Figure 150

INTERNAL COMPONENTS (Cont'd)

36. Install the center support assembly, ensuring that you align the hole for the center support with the proper passage (See Figure 151).
37. Loosely install the center support retaining bolt as shown in Figure 152.

Continued on Page 87

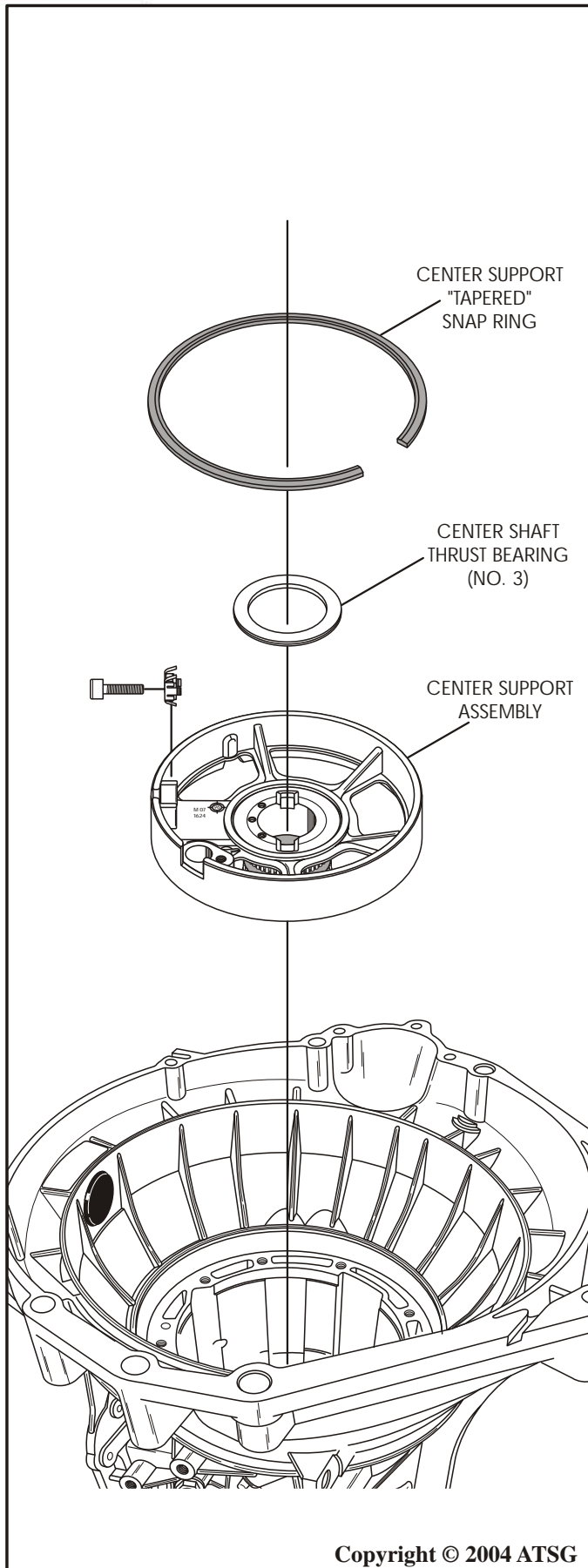

Figure 151

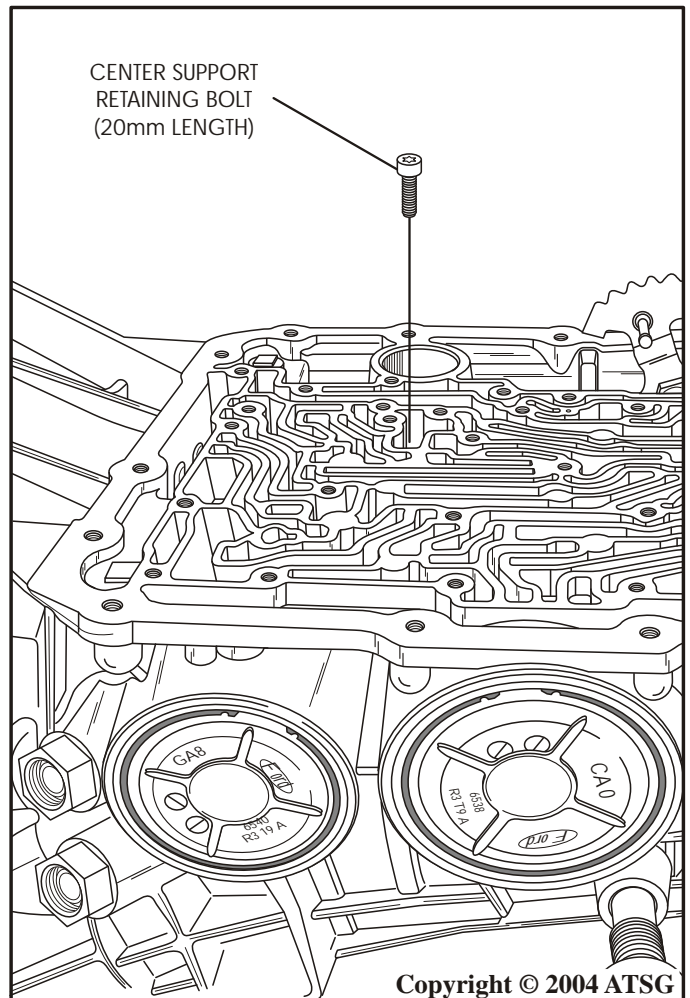

Figure 152

INTERNAL COMPONENTS (Cont'd)

38. Install the center support snap ring with the opening in the snap ring to the opening in the center support, as shown in Figure 153.
39. Now we must once again measure with the dial caliper through the speed sensor hole down to the surface of the direct clutch housing with all of the parts installed in the case, as shown in Figure 155, **and record this as dimension "B"**.
40. Subtract previously recorded dimension "A" from now recorded dimension "B", and this will give you the rear end clearance.
Example: Dimension "B" = .735"
Dimension "A" = .725"
Difference = .010"
41. Rear end clearance should be .008" to .012". Change the selective No. 4 thrust bearing using the chart in Figure 154, as necessary to arrive at the proper end play.

Continued on Page 88

SELECTIVE NO. 4 THRUST BEARING CHART		
THICKNESS	PART NO.	I.D. NOTCHES
.104" - .110"	XW4Z-7D014-CA	None
.111" - .117"	XW4Z-7D014-DA	One
.118" - .125"	XW4Z-7D014-EA	Two
.126" - .132"	XW4Z-7D014-FA	Three

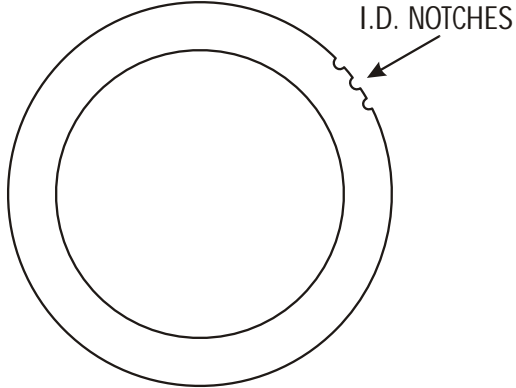

Figure 154

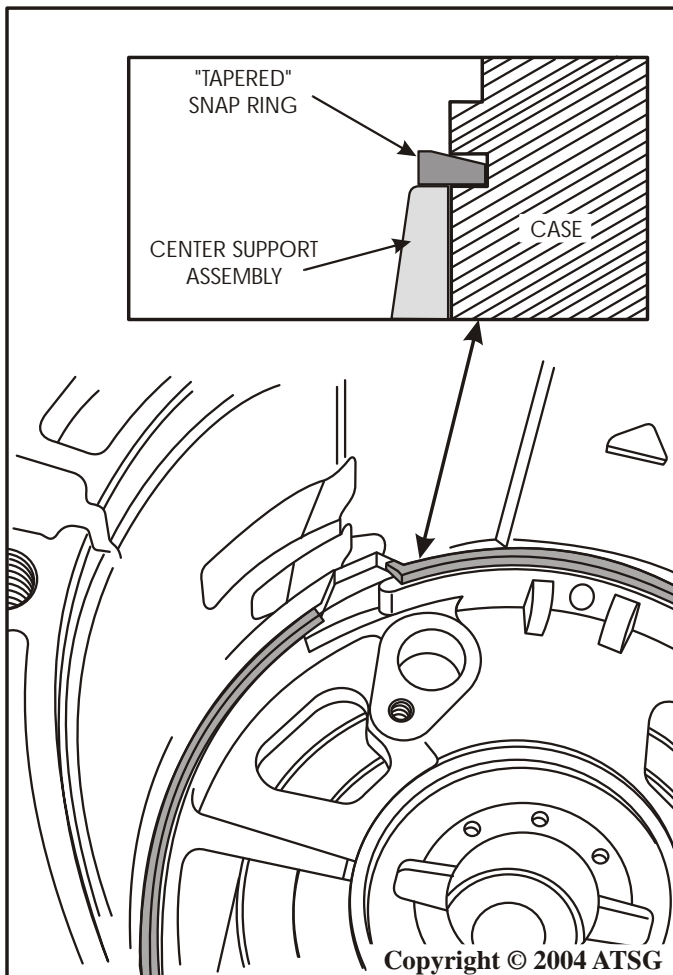

Figure 153

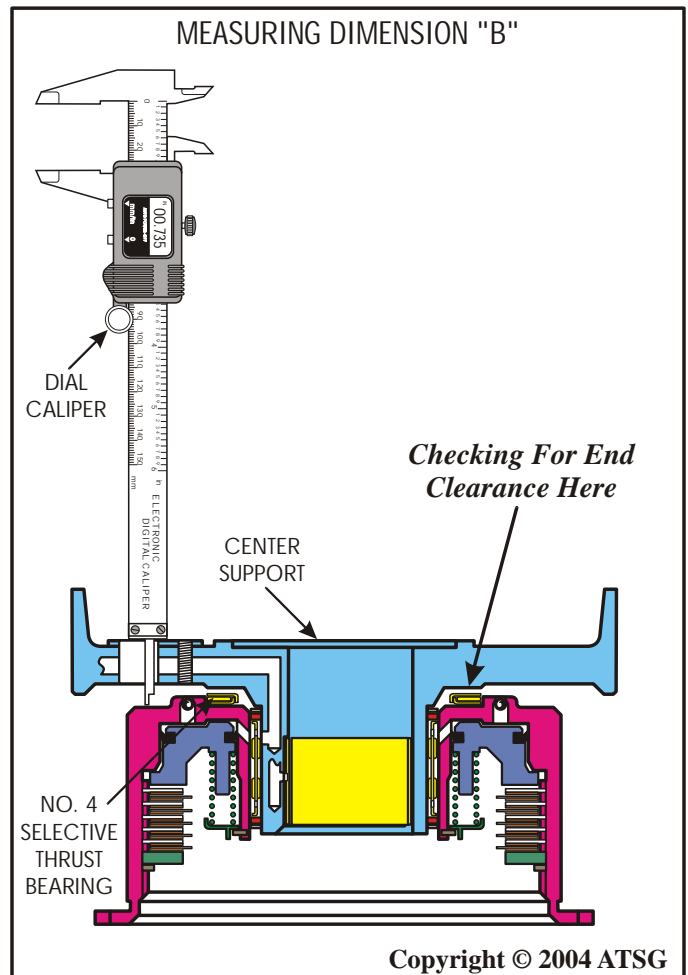

Figure 155

INTERNAL COMPONENTS (Cont'd)

42. Install the center shaft to center support thrust bearing (No. 3) onto the center support, as shown in Figure 156.
43. Install the pre-assembled overdrive carrier and center shaft assembly, as shown in Figure 157, ensuring that it is splined into the forward clutch housing and fully seated.

Caution: There are two different overdrive ratios for this unit, 0.75 and 0.71. This will affect the overdrive carrier, overdrive ring gear, overdrive sun gear, overdrive sun gear adapter plate and the coast clutch housing.

For overdrive planetary carrier identification refer to Figure 158.

For overdrive planetary ring gear identification refer to Figure 159.

For overdrive sun gear and sun gear adapter plate identification refer to Figure 160.

For the coast clutch housing identification refer to Figure 161.

NONE OF THE PARTS LISTED ABOVE ARE COMPATABLE WITH ONE ANOTHER

44. Install the overdrive sun gear into overdrive carrier, as shown in Figure 157, by rotating into position.
45. Install the coast clutch housing adapter plate on overdrive sun gear, as shown in Figure 157, and ensure that it is fully seated.

Continued on Page 92

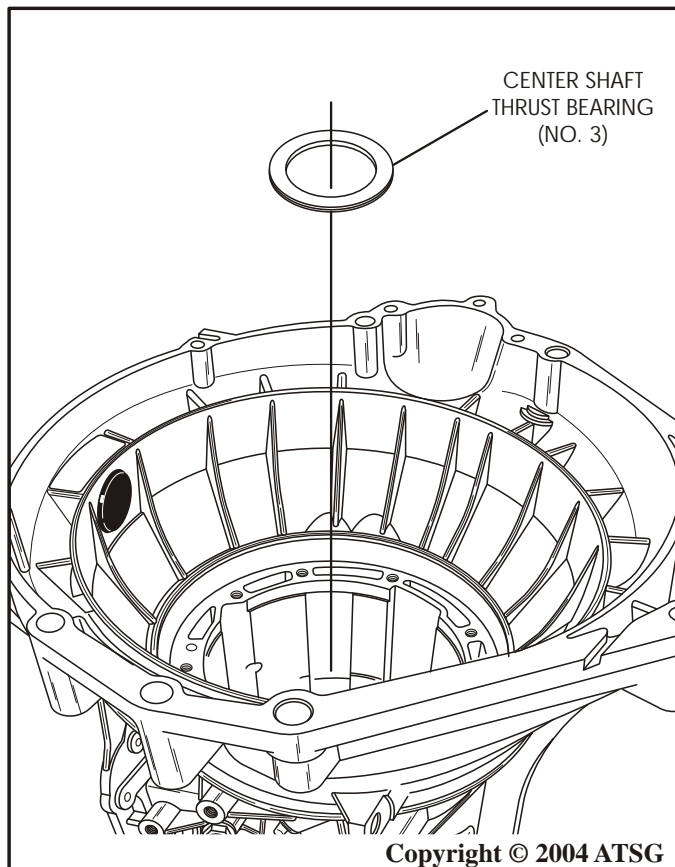

Figure 156

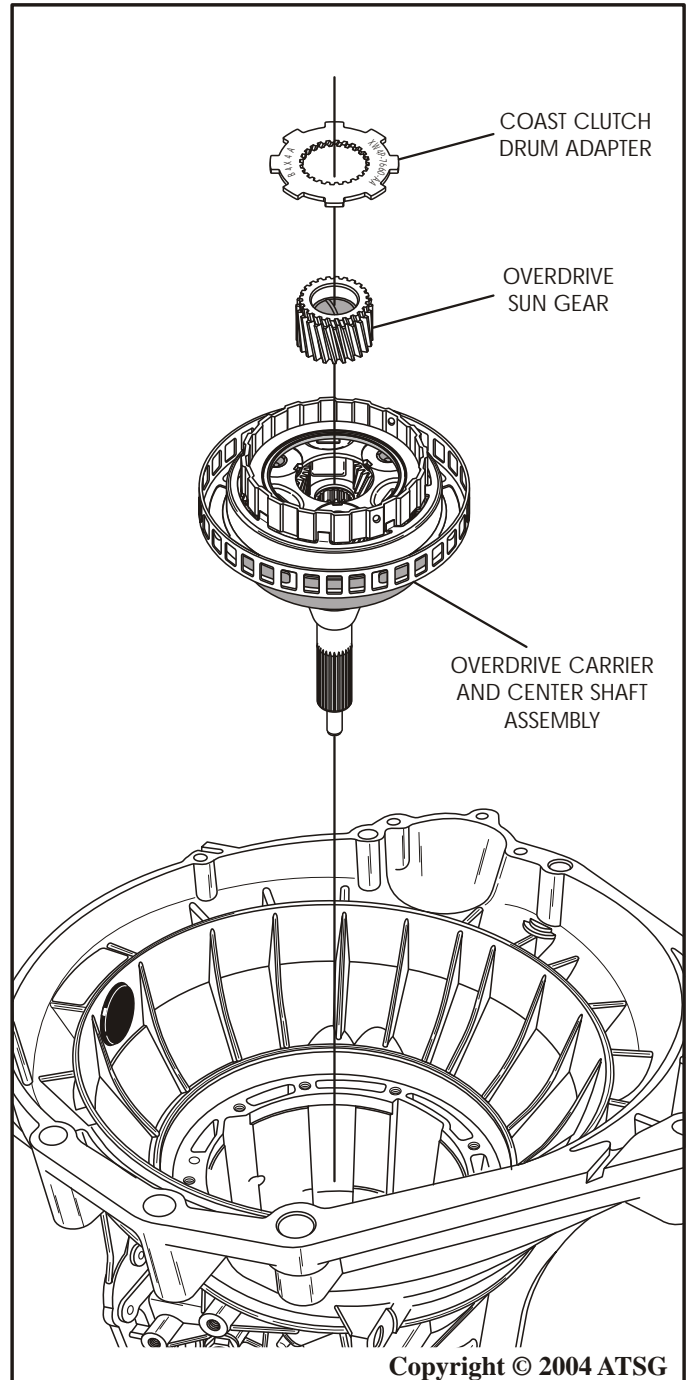
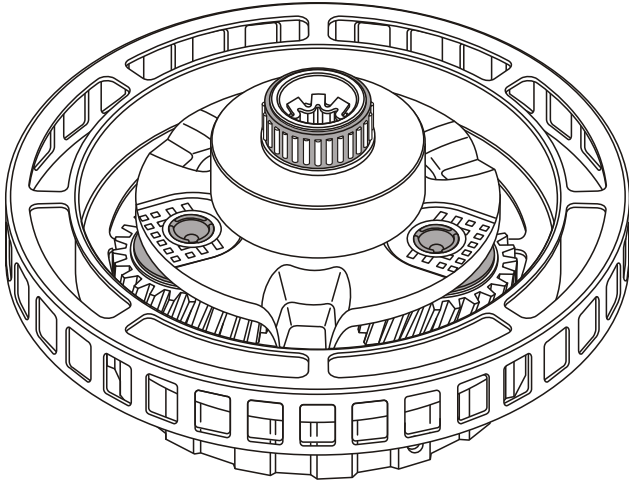

Figure 157

OVERDRIVE PLANETARY CARRIER

*0.75 Ratio Overdrive Carrier
25 Tooth Pinion Gears*



*0.71 Ratio Overdrive Carrier
28 Tooth Pinion Gears*

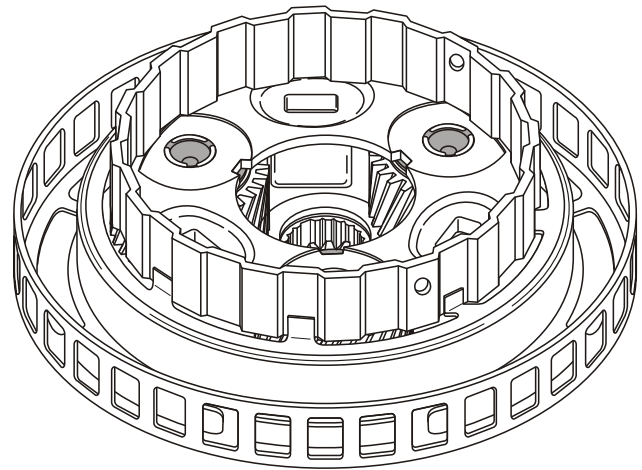
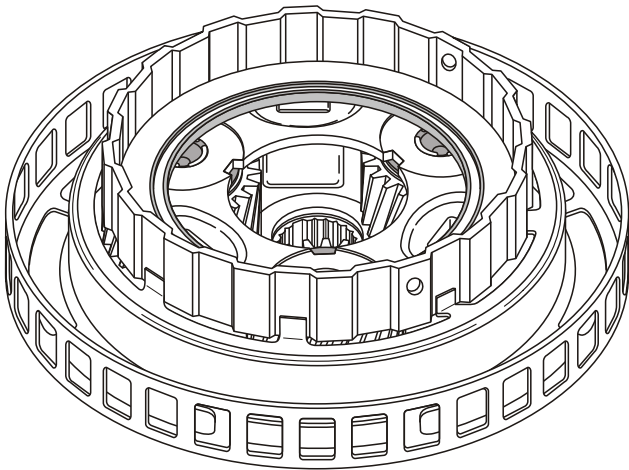
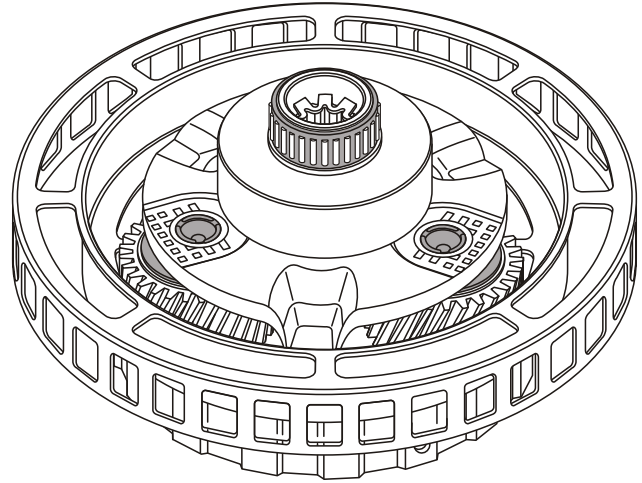

Copyright © 2004 ATSG

Figure 158

OVERDRIVE INTERNAL RING GEAR

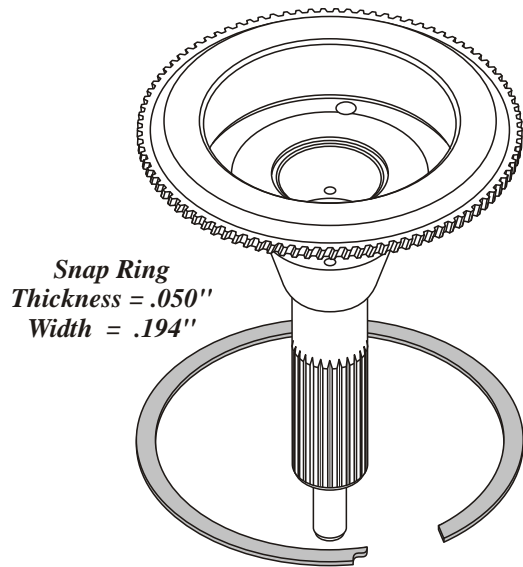
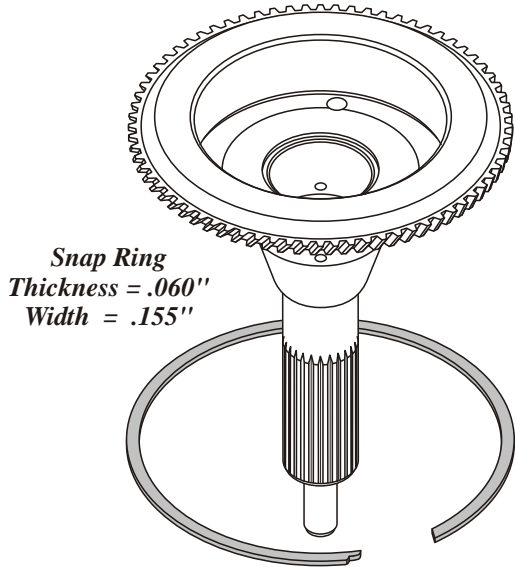
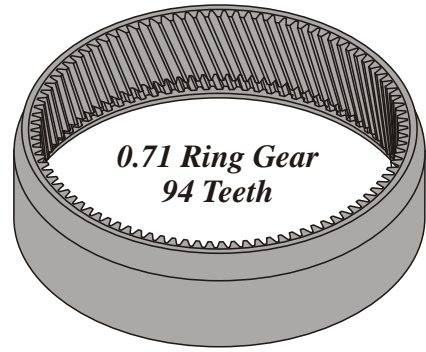

Copyright © 2004 ATSG

Figure 159

OVERDRIVE SUN GEAR AND ADAPTER PLATE

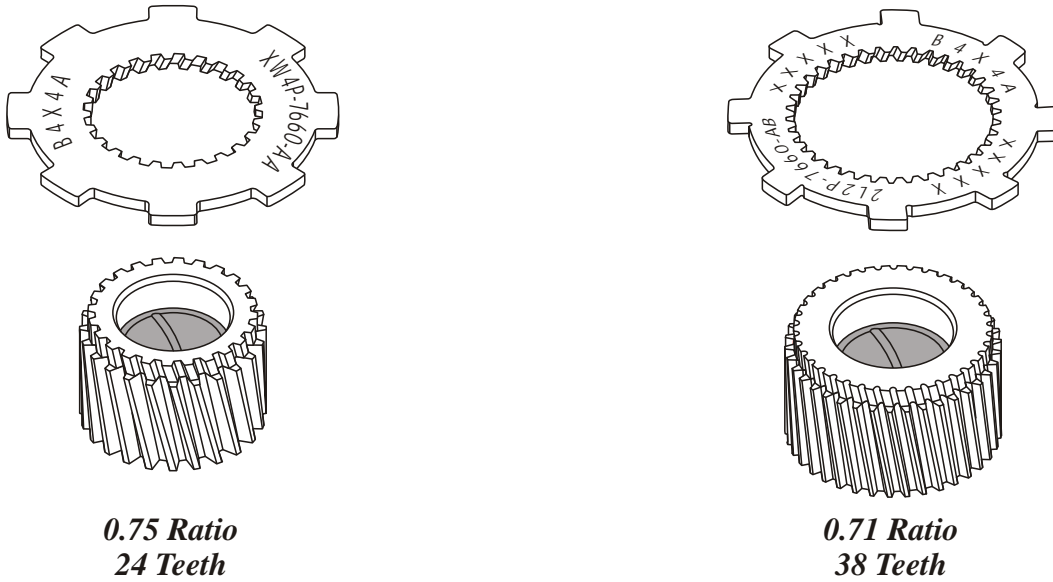

Copyright © 2004 ATSG

Figure 160

OVERDRIVE SUN GEAR ADAPTER PLATE AND COAST CLUTCH HOUSING

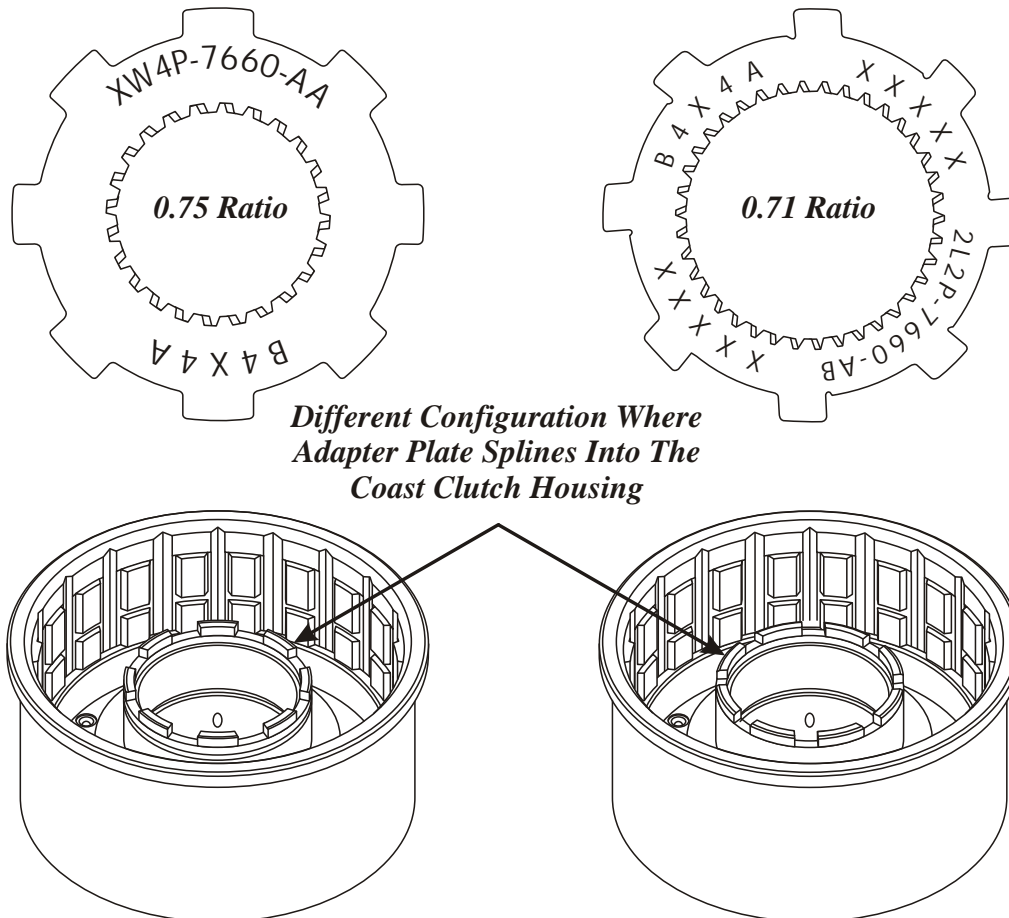

Copyright © 2004 ATSG

Figure 161

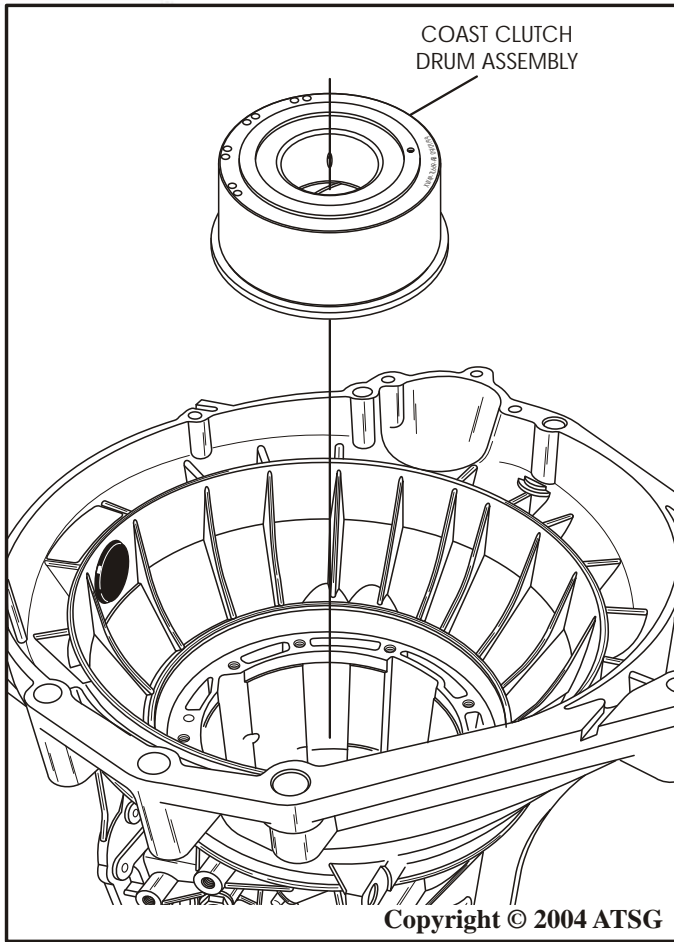

Figure 162

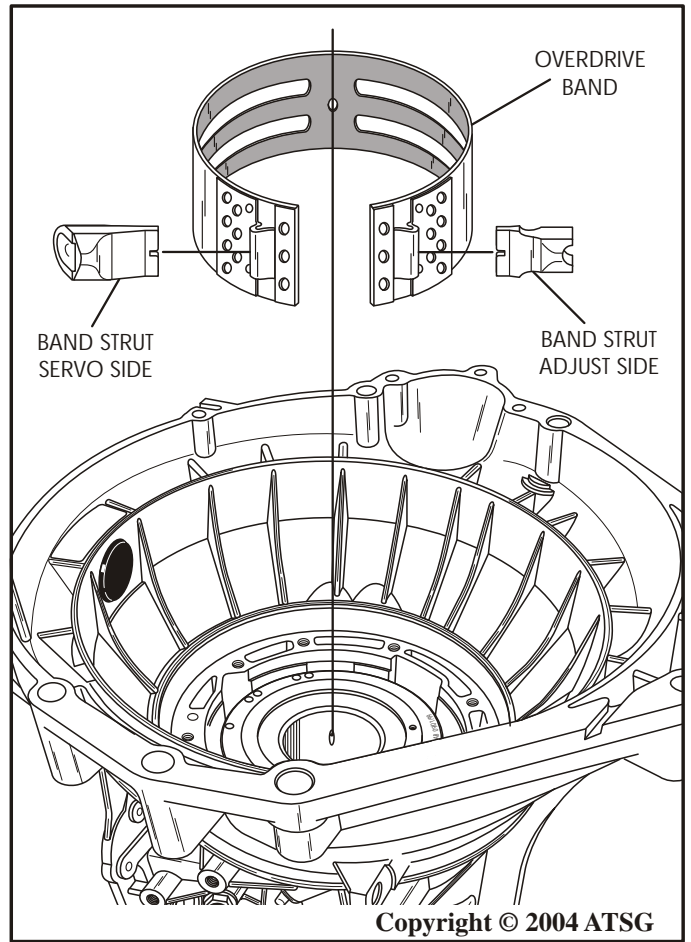

Figure 163

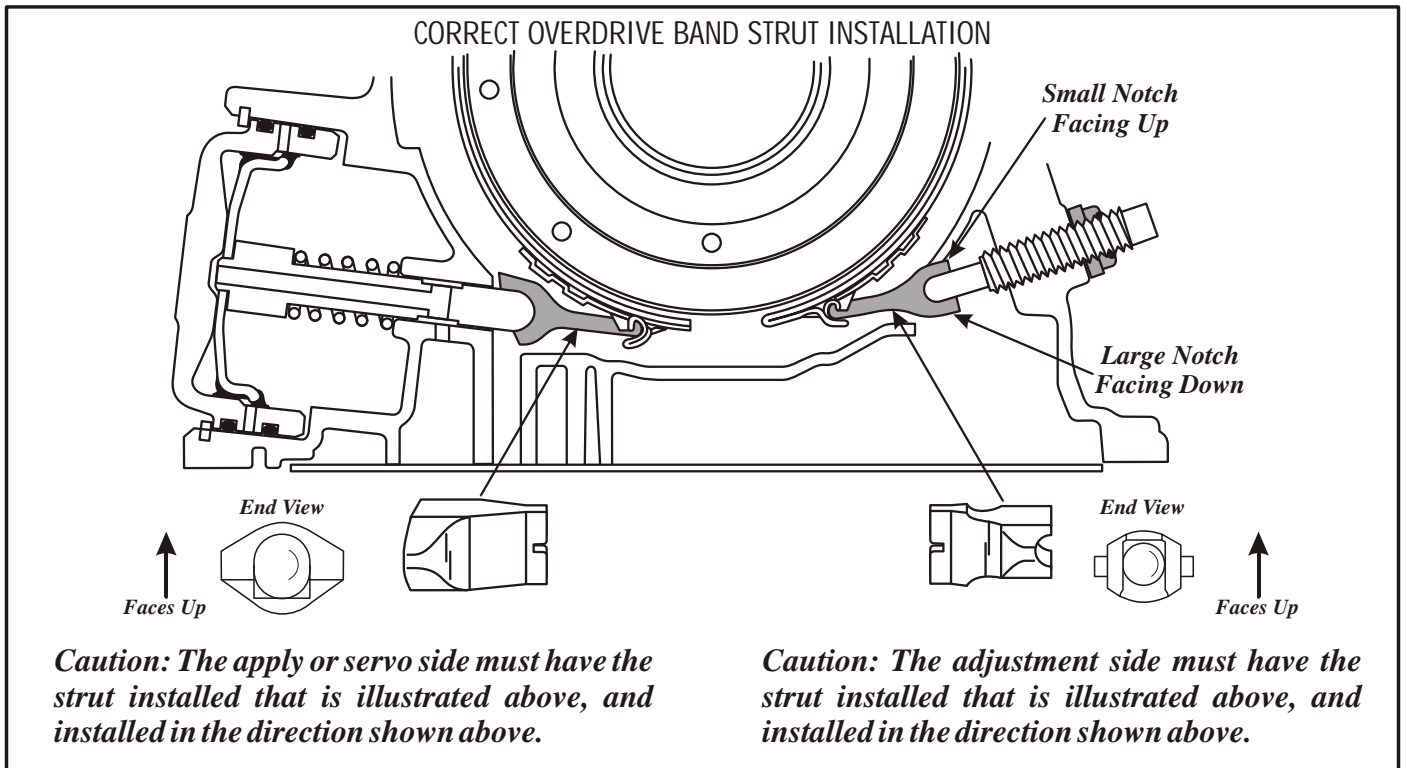

Figure 164

INTERNAL COMPONENTS (Cont'd)

46. Install the pre-assembled coast clutch housing, as shown in Figure 162, by rotating back and forth to engage clutches on hub, until fully seated.
47. Install the overdrive band into transmission and around the coast clutch housing, as shown in Figure 163.
48. Install the overdrive band struts on each side of the band, *exactly* as shown in Figure 163.
Caution: The anchor or adjustment side must have strut installed that is illustrated in Figure 164 and must be installed with the small notch facing the top of transmission. The apply or servo side must also be installed, as shown in Figure 164.
49. Install "H" gauge onto case pump surface and move center rod down to surface on the coast clutch where selective thrust washer rides, as shown in Figure 165.

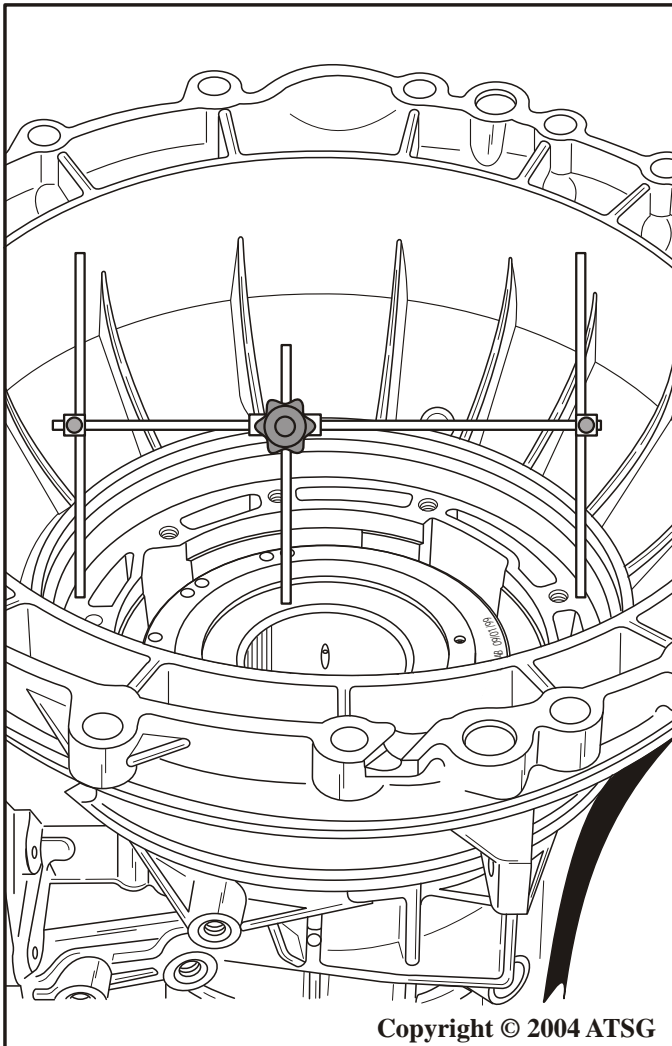

Figure 165

50. Install pump gasket onto the pre-assembled oil pump, as shown in Figure 166.
51. Place the "H" gauge with the previously set center rod onto the oil pump in the opposite direction, with the center rod placed over the selective washer, as shown in Figure 166.
52. Measure with a feeler gage between the center rod and selective thrust washer, as shown in Figure 166.
53. Front end clearance should be .012" - .018". Change the selective oil pump thrust washer from the chart below, as necessary, to achieve proper front end clearance.

Continued on Page 94

SELECTIVE OIL PUMP THRUST WASHER CHART		
THICKNESS	PART NO.	I.D. COLOR/NO.
.066" - .069"	XW4Z-7D014-XA	Brown/"8"
.073" - .075"	XW4Z-7D014-NA	Red/"4"
.080" - .082"	XW4Z-7D014-RA	Black/"6"
.087" - .089"	XW4Z-7D014-YA	Orange/"9"
.094" - .096"	XW4Z-7D014-ZA	Purple/"10"

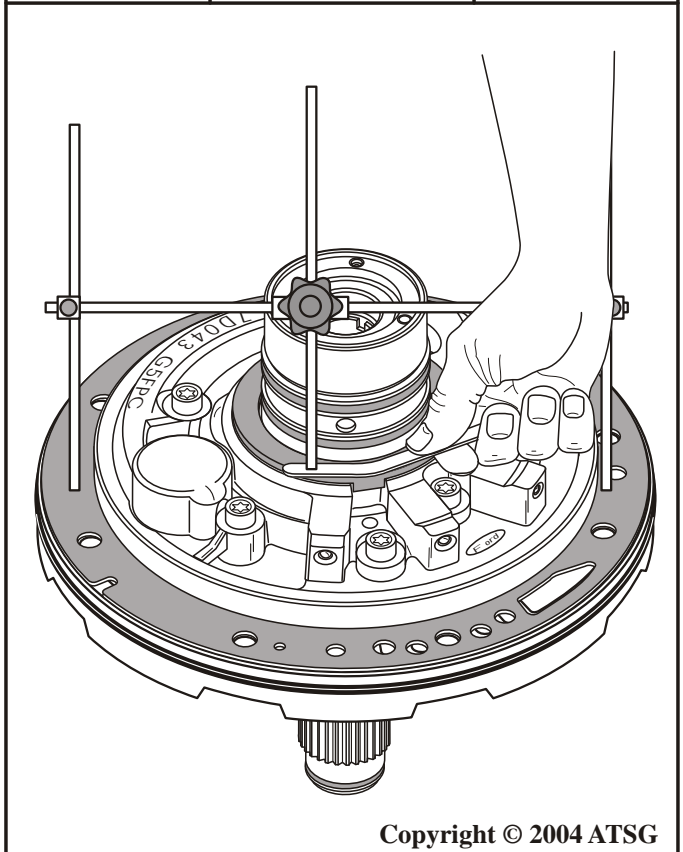

Figure 166

INTERNAL COMPONENTS (Cont'd)

54. Install the oil pump to case gasket into case, as shown in Figure 167, and align holes.
55. Lubricate the case bore where the "O" ring rides with a small amount of Trans-Jel®.
56. Install the pre-assembled oil pump assembly into the case, as shown in Figure 167, using care not to damage the pump "O" ring.
57. Install the eight oil pump assembly retaining bolts, and torque to 25Nm (18 ft.lb.), as shown in Figure 168.
58. Rotate the transmission so that the valve body surface is facing up, as shown in Figure 169.
59. Torque the center support retaining bolt down to 11 Nm (100 in.lb.), (See Figure 169).

Continued on Page 95

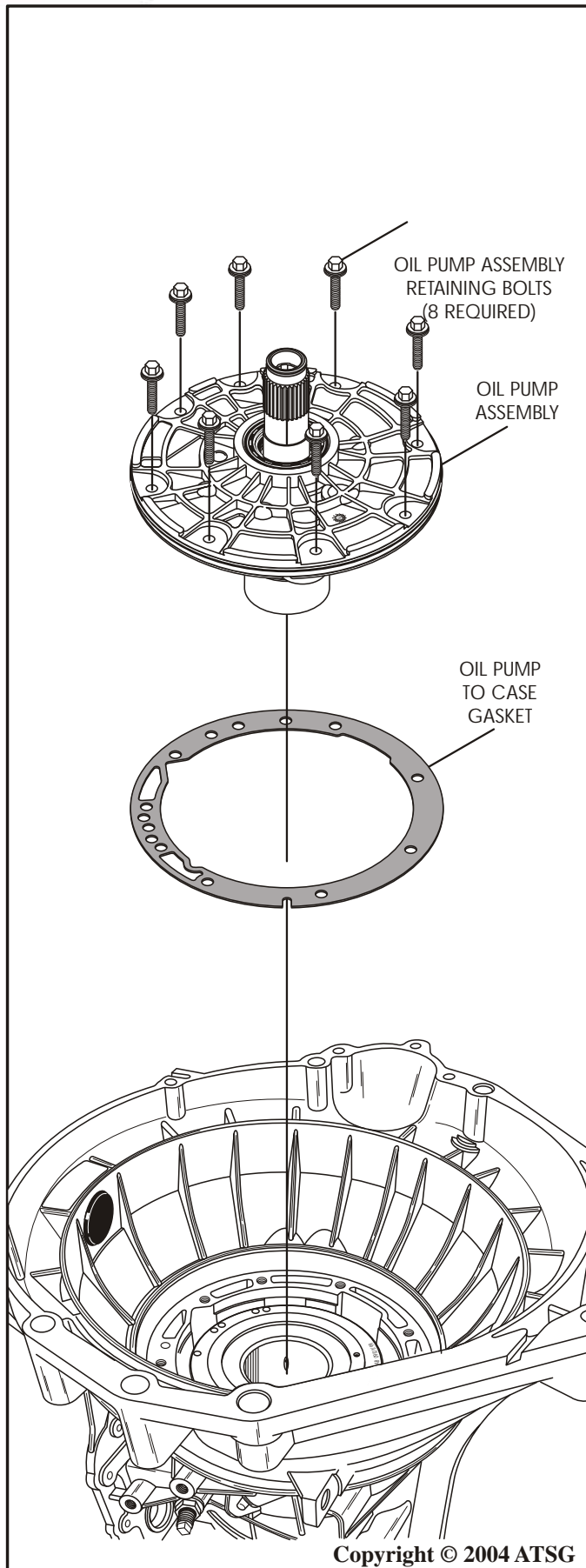

Figure 167

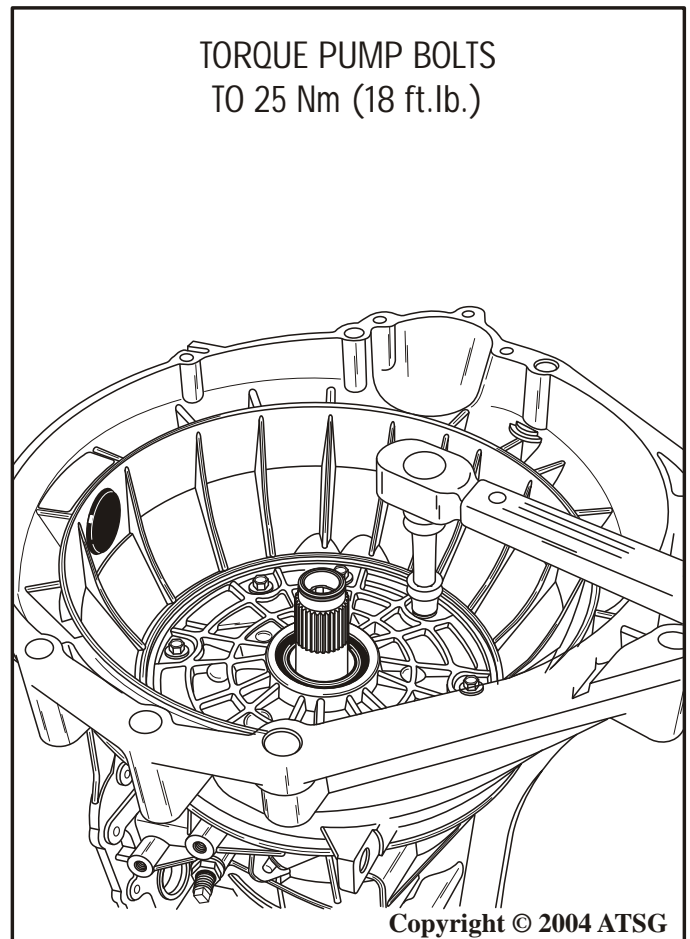

Figure 168

INTERNAL COMPONENTS (Cont'd)

63. Install new locking nuts on both band adjusting screws, using care not to let the adjusting screw come out, so that the band anchors will not fall out and into transmission (See Figure 170).
64. Adjust the overdrive band by turning adjusting screw in while holding the lock nut. Torque the adjusting screw to 14 Nm (10 ft.lb.) and then back out **exactly** 2 full turns for W/S models in trucks and 1-1/2 turns for S models in cars. Refer to Figure 170.
65. Adjust intermediate band by turning adjusting screw in while holding the lock nut. Torque the adjusting screw to 14 Nm (10 ft.lb.) and then back out **exactly** 2 full turns for W/S models in trucks and 1-1/2 turns for S models in cars. Refer to Figure 170.
66. Torque both locking nuts to 54 N•m (40 ft.lb.), while holding adjusting screw.

Continued on Page 97

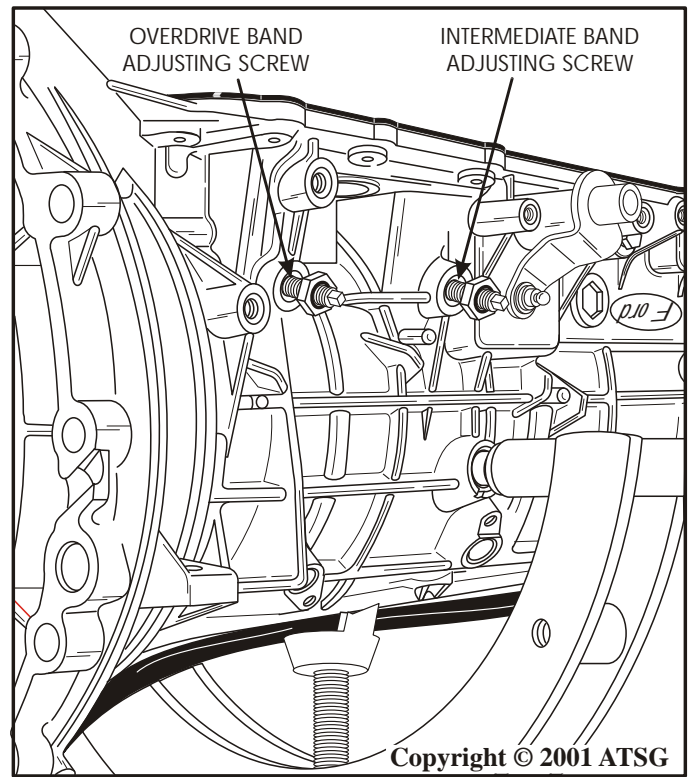

Figure 170

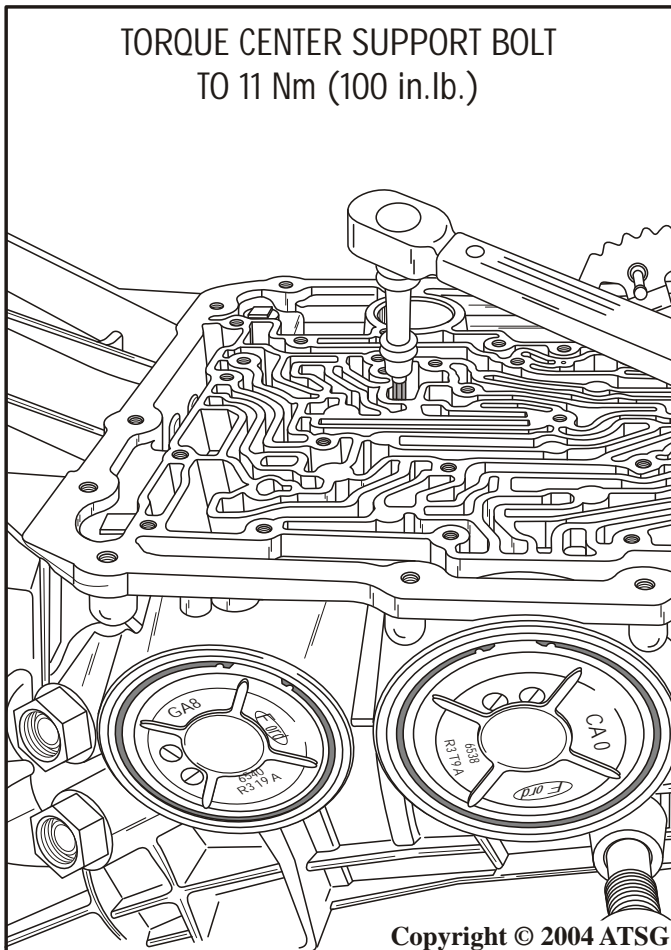
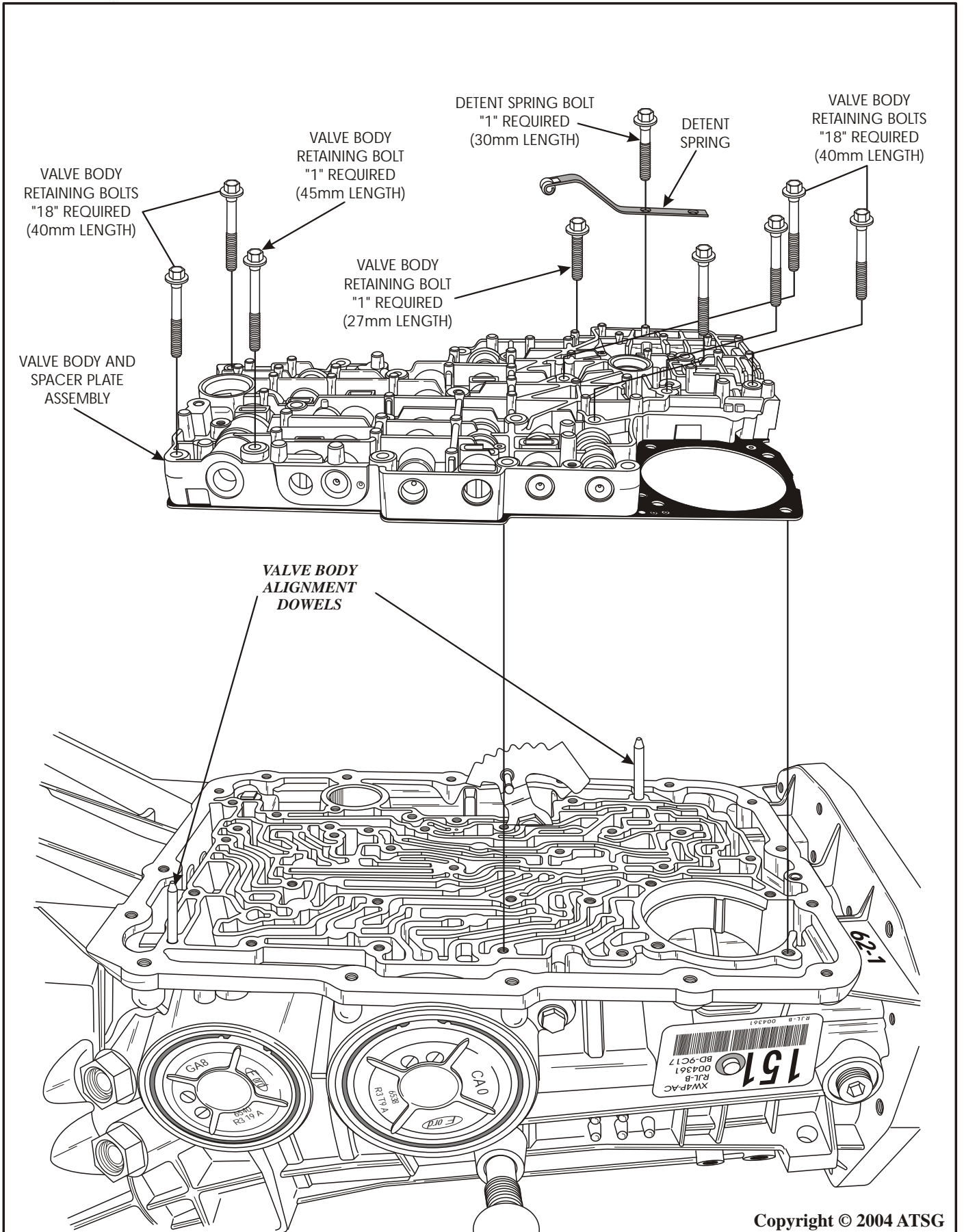

Figure 169



Copyright © 2004 ATSG

Figure 171

INTERNAL COMPONENTS (Cont'd)

67. Install the two valve body alignment dowels in the locations shown in Figure 171.
68. Install the pre-assembled valve body and spacer plate, as shown in Figure 171.

Caution: Ensure that manual valve is engaged on the inside detent lever properly.
69. There are four different lengths of valve body bolts, as shown in Figure 172.
70. Install the 27mm length bolt finger tight only, in the location shown in Figure 173.
71. Install the 45mm length bolt finger tight only, in the location shown in Figure 173.
72. Install the remaining 18, 40mm length valve body bolts, in locations shown in Figure 173, and finger tighten only at this time.
73. Install the detent spring assembly, as shown in Figure 171, using the only 30mm length bolt, and finger tighten only at this time.

Continued on Page 99

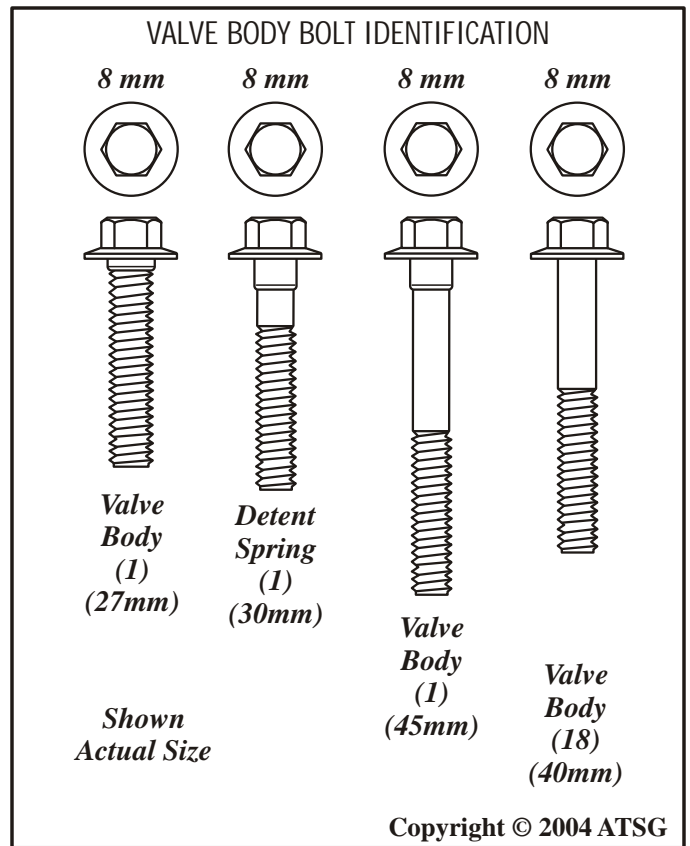

Figure 172

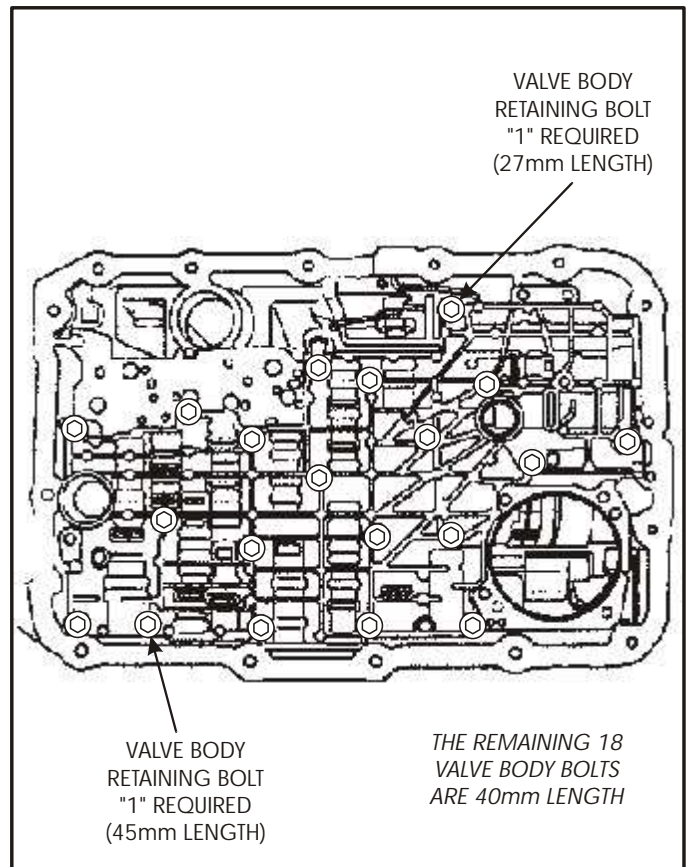
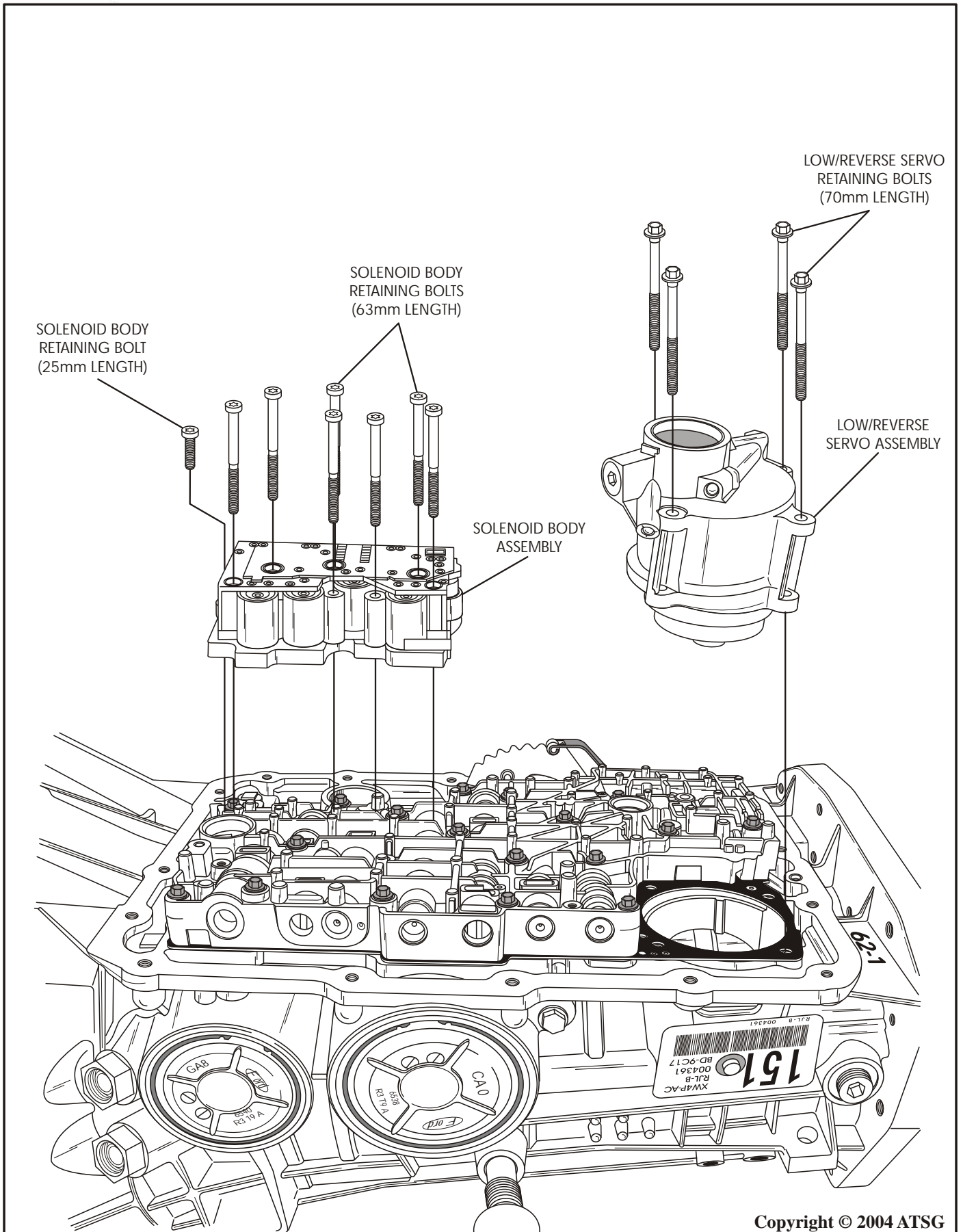

Figure 173



Copyright © 2004 ATSG

Figure 174

INTERNAL COMPONENTS (Cont'd)

74. Install the pre-checked solenoid body assembly onto transmission, as shown in Figure 174, and finger tighten only at this time.

Caution: Use small amount of *Trans-Jel®* on solenoid body connector "O" rings to help prevent damage.

75. Install pre-assembled reverse servo assembly onto spacer plate, as shown in Figure 174, and finger tighten only at this time.

76. Torque all of the valve body bolts to 10 N•m (89 in.lb.), beginning in the center and working outward in a circle.

77. Torque all of the solenoid body bolts to 8 N•m (71 in.lb.), using a criss-cross pattern.

78. Torque all of the reverse servo bolts to 10 N•m (89 in.lb.), using a criss-cross pattern.

79. Install new filter seals on new filter and install filter assembly, as shown in Figure 175.

80. Torque both filter bolts to 10 N•m (89 in.lb.).

81. Install new pan gasket onto transmission case, as shown in Figure 176.

Note: The bottom pan gasket is reusable. Clean and inspect the gasket for damage, and if it is not damaged, it may be re-used.

82. Install the bottom pan assembly and the sixteen bottom pan bolts, as shown in Figure 176, and torque pan bolts to 11 N•m (8 ft.lb.) using the criss-cross pattern.

83. Rotate transmission in fixture so that the rear is facing up, as shown in Figure 177.

84. Remove the output shaft holding strap if you have not already done so (See Figure 177).

Continued on Page 100

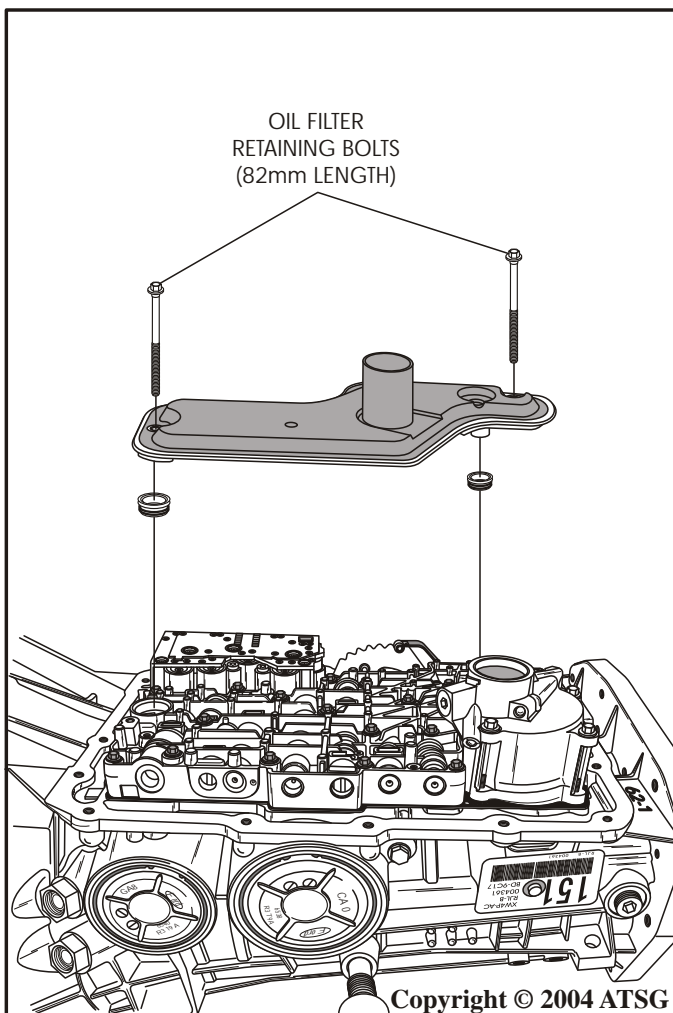

Figure 175

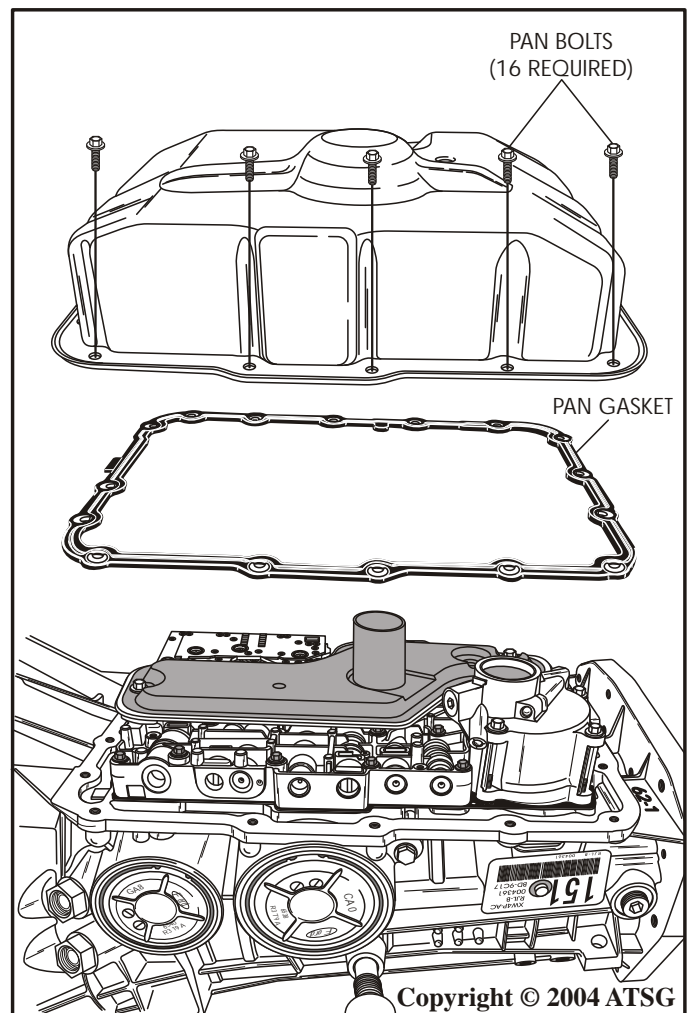

Figure 176

TWO WHEEL DRIVE ASSEMBLY

1. Inspect and replace extension housing bushing as necessary using the proper removal tool and bushing driver (See Figure 178).
2. Install a new extension housing yoke seal, as shown in Figure 178, using the proper driver.
3. Install a new extension housing gasket onto the case, as shown in Figure 179.
4. Install the completed extension housing onto the transmission, as shown in Figure 179.
5. Install the seven extension housing bolts, as shown in Figure 179.

Note: *The extension housing bolts for the 2WD version are longer than the 4WD adapter housing bolts (See Figure 180).*

6. Torque the extension housing bolts down to 26 N•m (19 ft.lb.), as shown in Figure 181.

Continued on Page 102

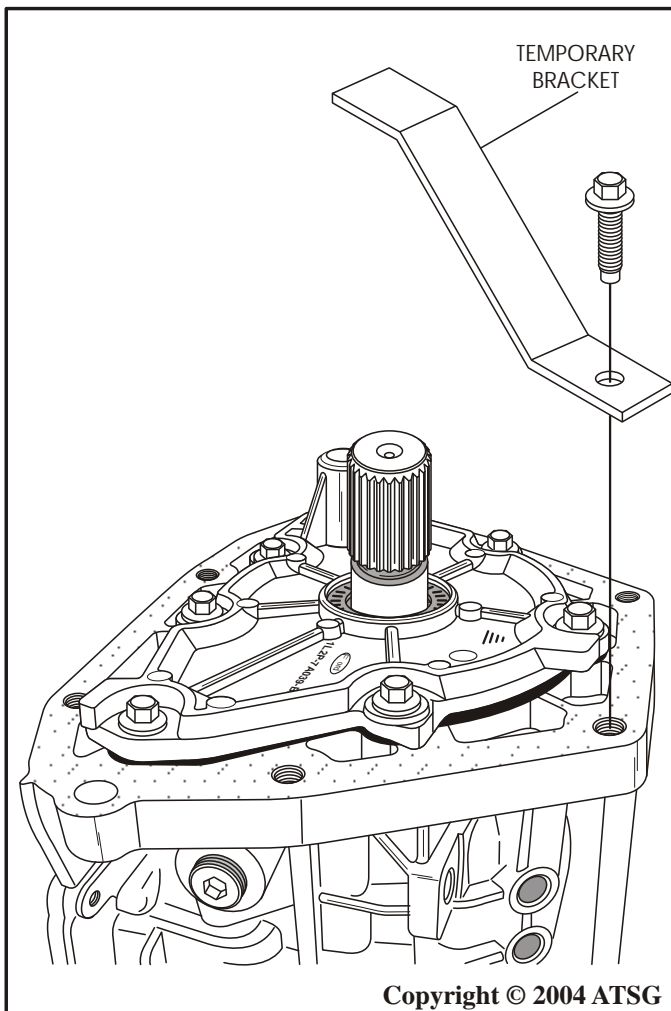

Figure 177

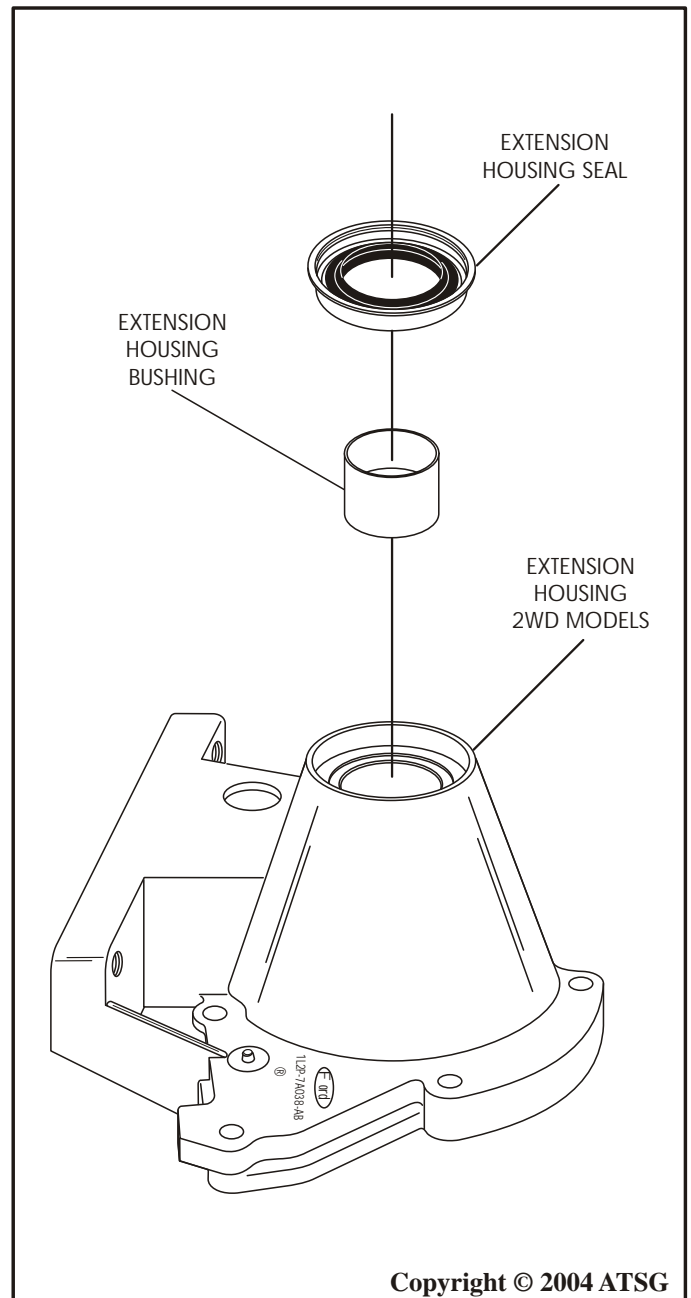

Figure 178

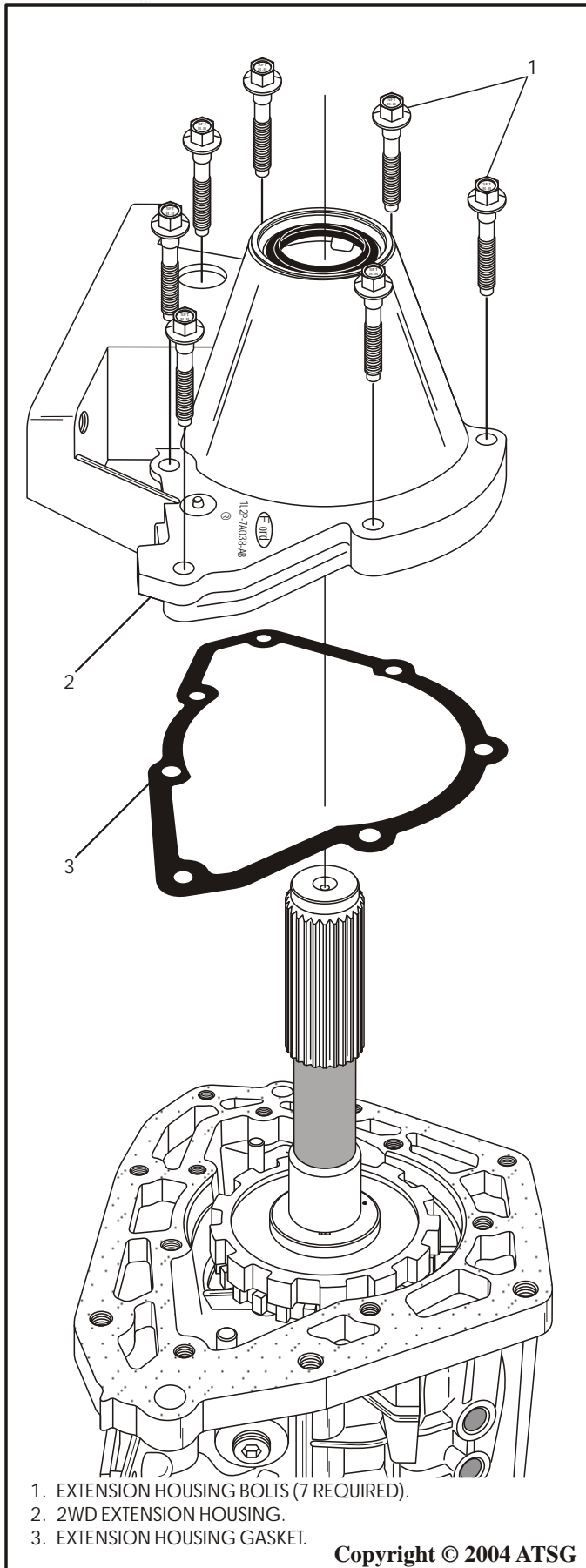

Figure 179

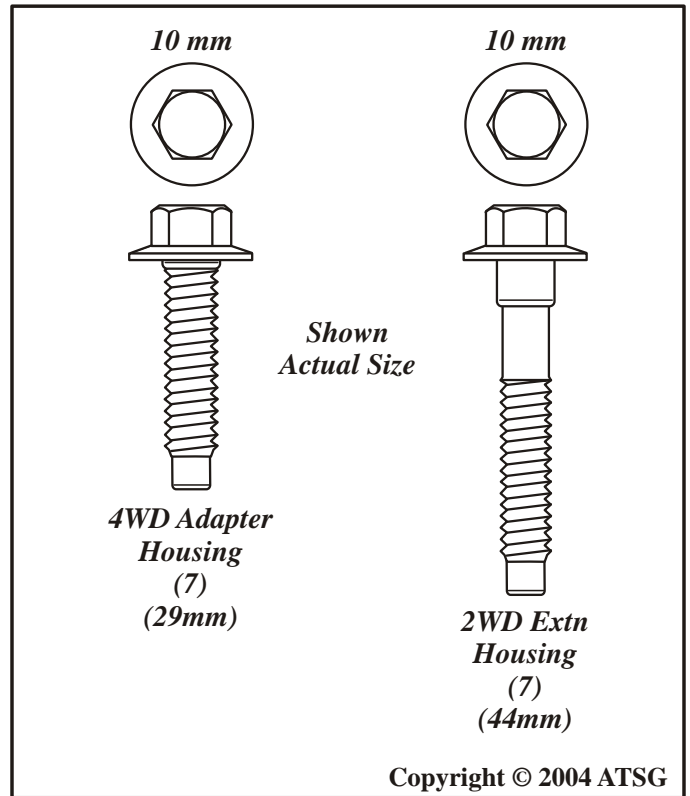

Figure 180

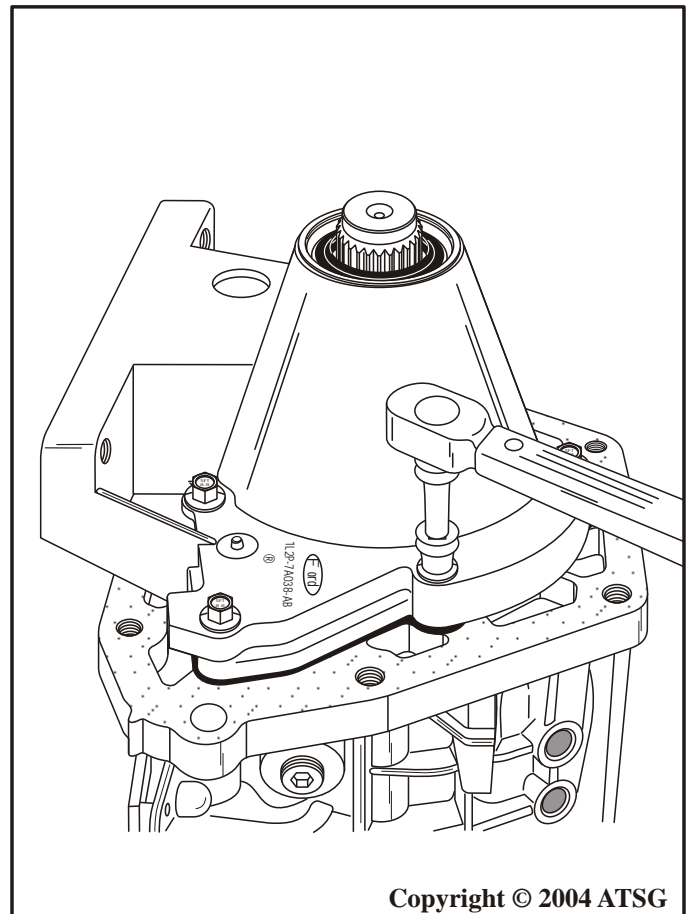

Figure 181

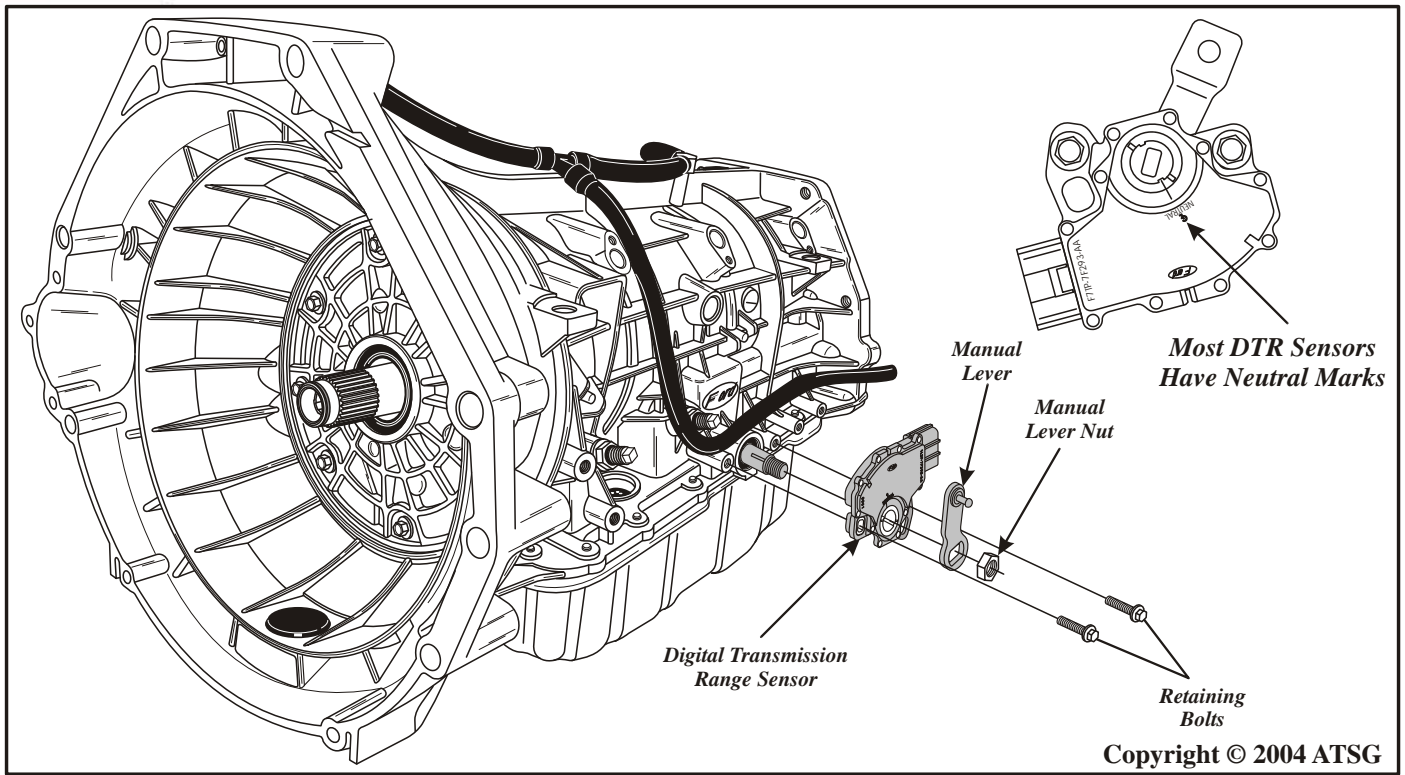

Figure 182

EXTERNAL COMPONENTS

1. Place the manual lever in the neutral position and install the Digital Transmission Range sensor, as shown in Figure 182.
2. Install the two DTR retaining bolts finger tight at this time (See Figure 182).
3. Install the adjustment gage and tighten the two DTR bolts by alternating from side to side, and torque to 10 Nm (89 in.lb.).

Continued on Page 103

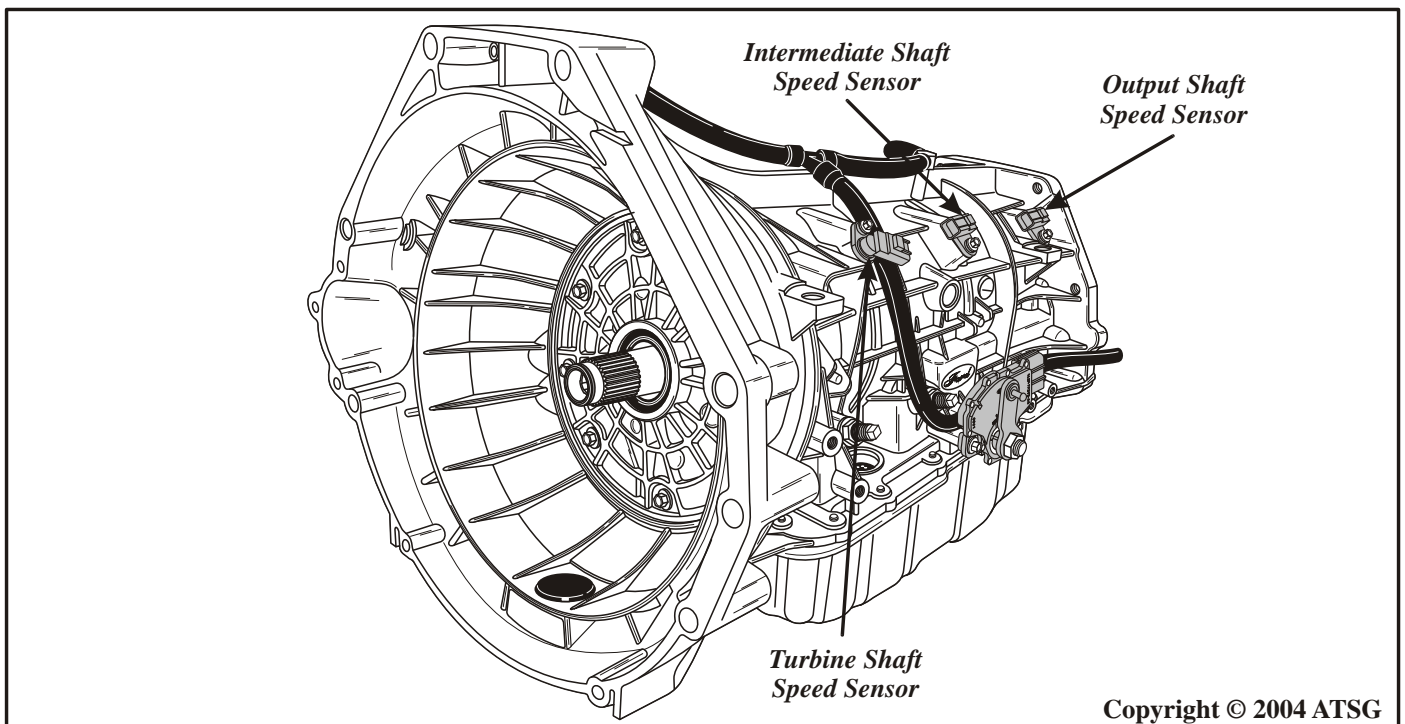

Figure 183

EXTERNAL COMPONENTS (Cont'd)

4. Install the outer manual control lever and nut, torque nut to 48 N•m (35 ft.lb.).
5. Install a new "O" ring on turbine speed sensor and install into case in the location, as shown in Figure 183.
Note: Use Figure 184 to identify the three speed sensor assemblies, and use the chart on Page 17 for proper Ohms readings.
6. Install a new "O" ring on the intermediate shaft speed sensor and install into case in the location shown in Figure 183.
Note: Use Figure 184 to identify the three speed sensor assemblies, and use the chart on Page 17 for proper Ohms readings.
7. Install a new "O" ring on output shaft speed sensor and install in case in the location shown in Figure 183.
Note: Use Figure 184 to identify the three speed sensor assemblies, and use the chart on Page 17 for proper Ohms readings.
8. Torque all three speed sensor retaining bolts to 10 Nm (89 in.lb.).

9. Check and ensure that both oil pressure plugs are tight, as shown in Figure 185.

Continued on Page 104

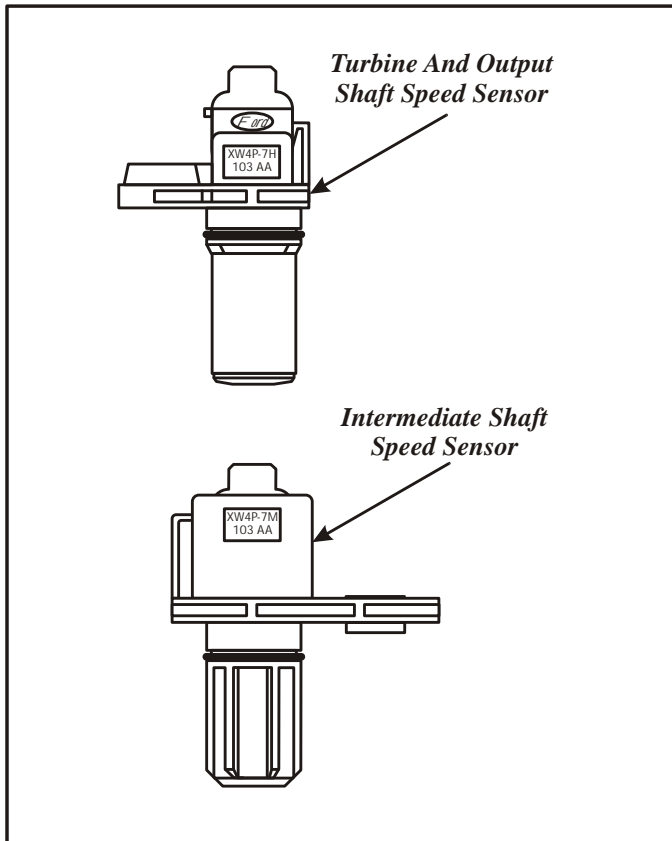
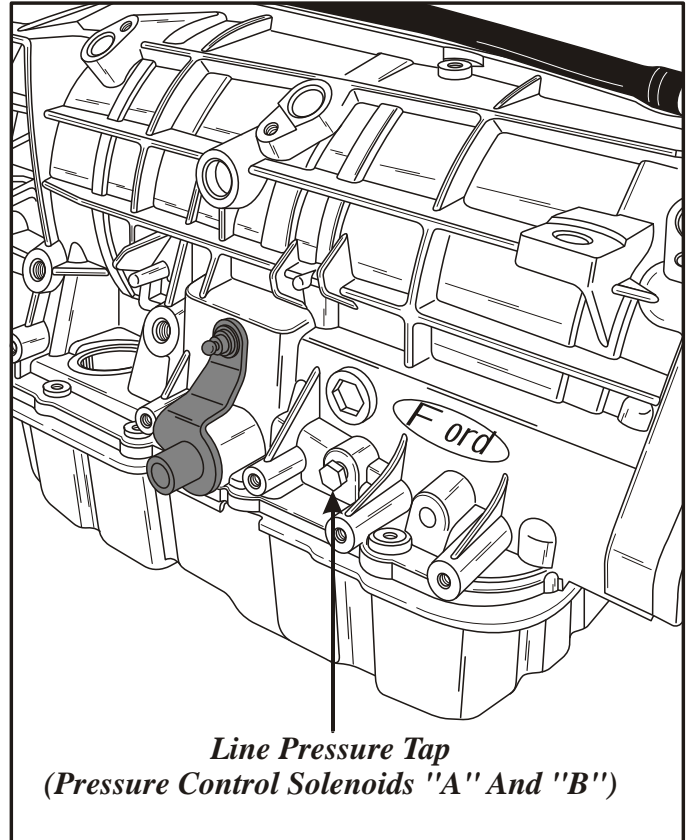
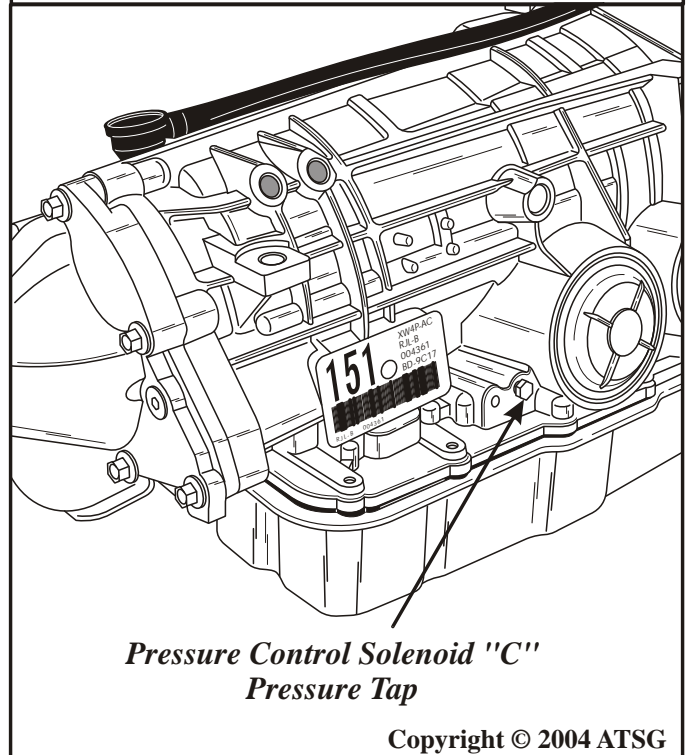

Figure 184



**Line Pressure Tap
(Pressure Control Solenoids "A" And "B")**



**Pressure Control Solenoid "C"
Pressure Tap**

Copyright © 2004 ATSG

Figure 185

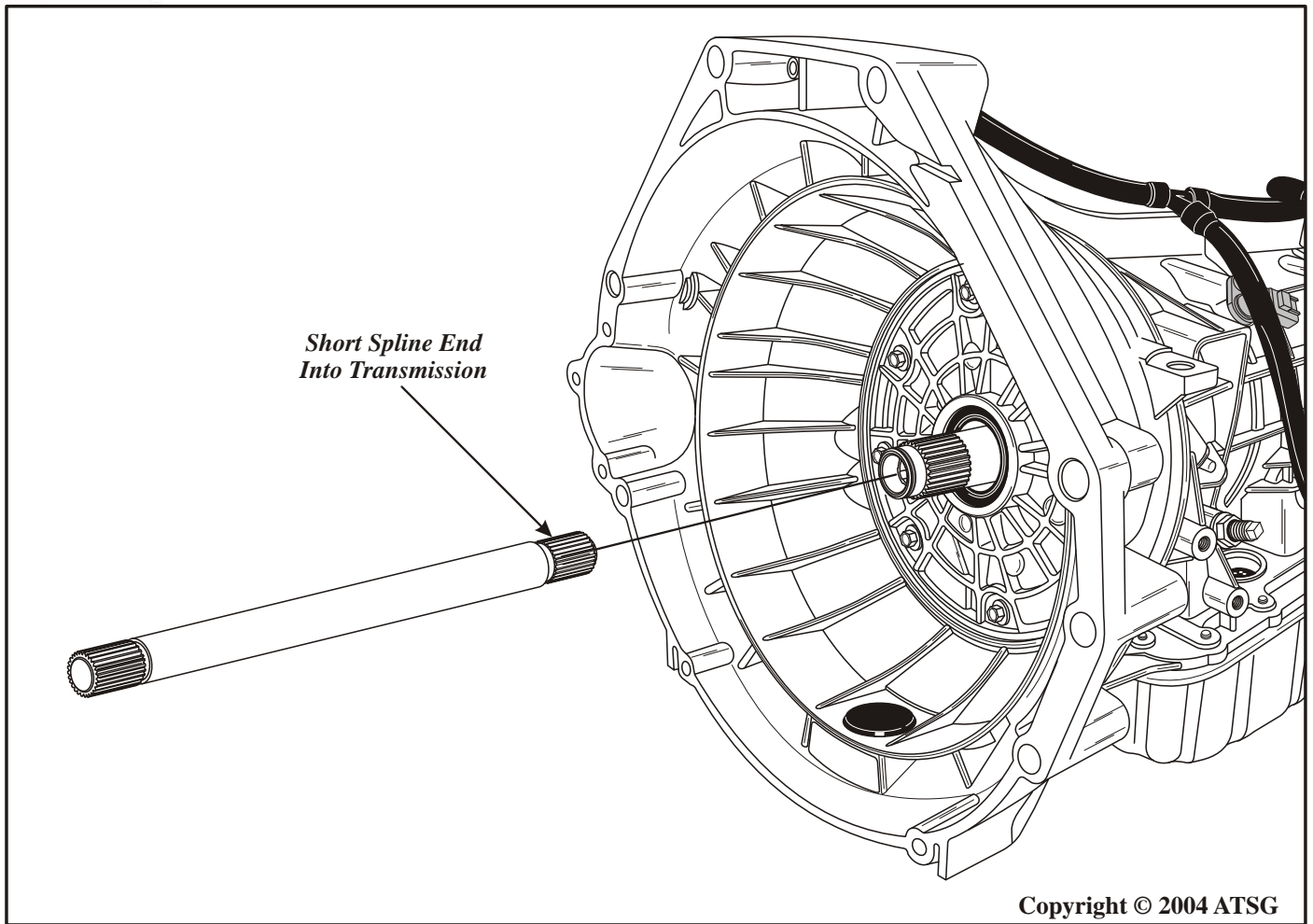

Copyright © 2004 ATSG

Figure 186

EXTERNAL COMPONENTS

9. Install the input shaft into the transmission, as shown in Figure 186.

Caution: *The splines on input shaft are not the same length on both ends. The end with the shorter splines goes into transmission, as shown in Figure 186.*

10. Remove form bench fixture and remove the universal transmission fixture.

CONGRATULATIONS!
YOU ARE FINISHED.

SPECIAL NOTE:
THIS UNIT REQUIRES MERCON® V.

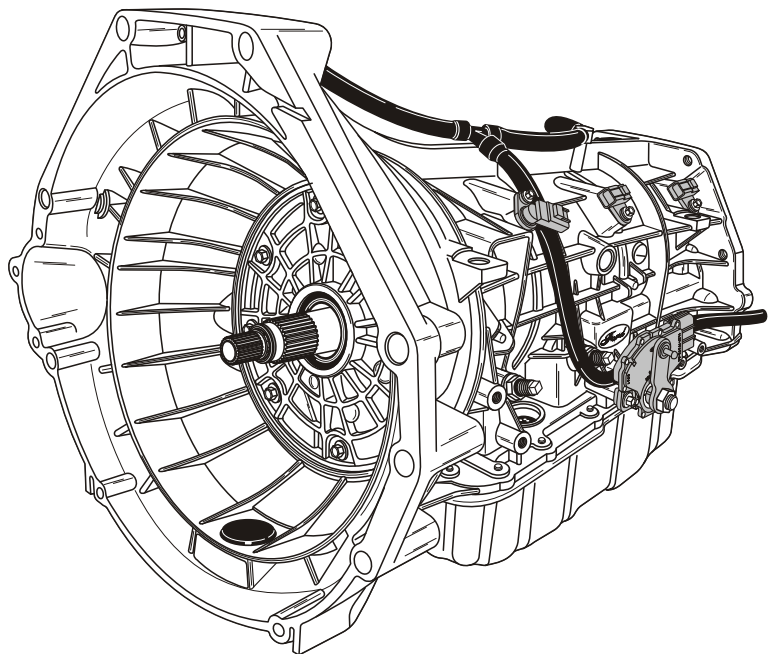

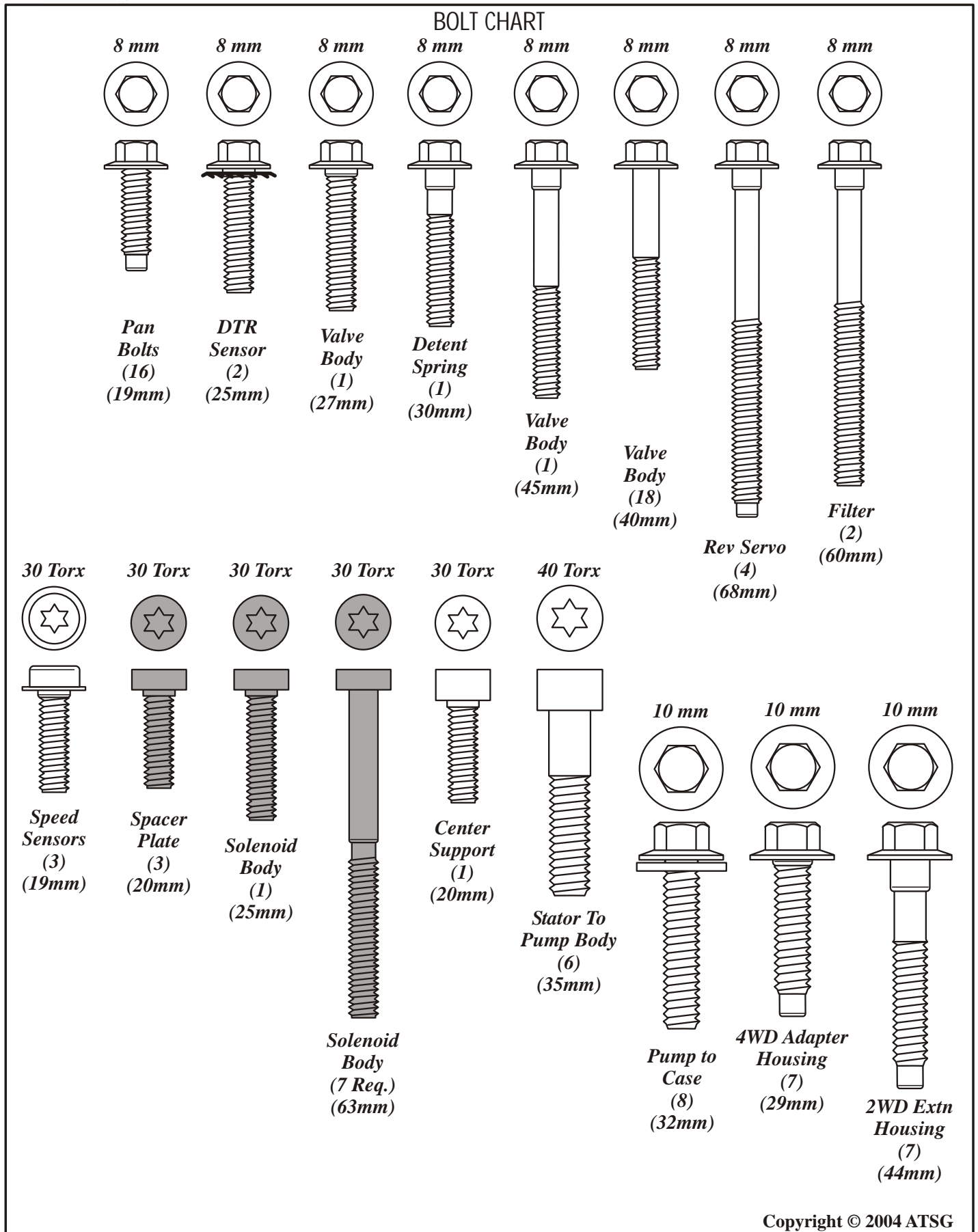

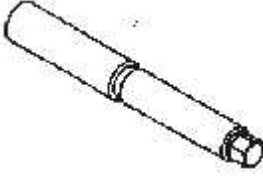
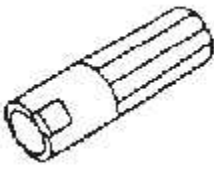
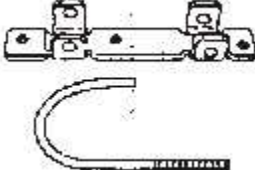
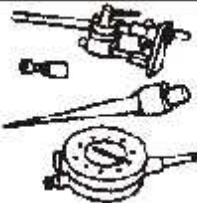
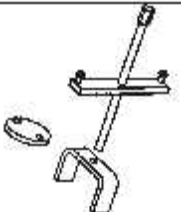

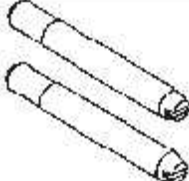
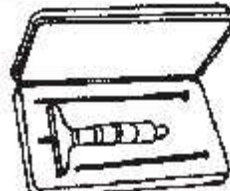

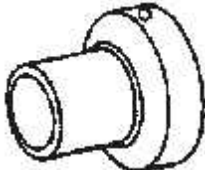

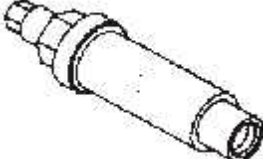



Figure 187

Technical Service Information

SPECIAL SERVICE TOOLS FORD OR "ROTUNDA" PART NUMBERS ARE REFERENCED

	<p>IMPACT SLIDE HAMMER 100-001 (T50T-100-A)</p>		<p>OIL PUMP ALIGNMENT TOOL 307-S039 (T74P-77103-X)</p>
	<p>OUTPUT SHAFT FLANGE INSTALLER 307-404</p>		<p>PUMP GEAR "O" RING SIZER 307-338 (T95L-700-10-G)</p>
	<p>SERVO COVER COMPRESSOR 307-402</p>		<p>DIAL INDICATOR 100-002 (TOOL-4201-C)</p>
	<p>INT CUSHION SPRING COMPRESSOR 307-401</p>		<p>TRS ALIGNMENT TOOL 307-351 (T97L-70010-A)</p>
	<p>OIL PUMP ALIGNMENT DOWELS 307-399</p>		<p>DEPTH MICROMETER 303-D206 (D8OP-4201-A)</p>
	<p>RETAINING RING PLIERS 307-343 (T95P-77001-AHR)</p>		<p>OUTPUT SHAFT BEARING INSTALLER 307-348 (T97T-77110-A)</p>
	<p>VALVE BODY GUIDE PIN (.248") 307-334 (T95L-70010-C) (2 REQUIRED)</p>		<p>BEARING REMOVER 308-047 (T77F-1102-A)</p>
	<p>OUTPUT FLANGE INSTALLER 205-479</p>		<p>BAND ADJUSTMENT TOOL 307-S022 (T71P-77370-A)</p>

Copyright © 2004 ATSG

Figure 188

SPECIAL SERVICE TOOLS FORD OR "ROTUNDA" PART NUMBERS ARE REFERENCED

	<p>EXTENSION HOUSING SEAL INSTALLER 307-038 (T74P-77052-A)</p>		<p>FORWARD CLUTCH INNER LIP SEAL PROTECTOR 307-051 (T74P-77548-A)</p>
	<p>COAST AND DIRECT CLUTCH INNER LIP SEAL PROTECTOR 307-049 (T74P-77404-A)</p>		<p>FORWARD CLUTCH OUTER LIP SEAL PROTECTOR 307-052 (T74P-77548-B)</p>
	<p>FRONT PUMP SEAL INSTALLER 307-349 (T97T-77000-A)</p>		<p>AIR TEST PLATE 307-405</p>
 <p><i>A very acceptable alternative for this tool is available from Trans-Tool in San Antonio and is universal so it works on many other models. Their part number is T-0033.</i></p>			<p>UNIVERSAL PULLER 307-001 (TOOL-1175-AC)</p>
			<p>OUTPUT FLANGE REMOVAL TOOL 307-408</p>
			<p>Copyright © 2004 ATSG</p>

Figure 189

TORQUE SPECIFICATIONS			
Description	Nm	In.Lb.	Ft.Lb.
Pump Stator To Pump Cover	25		18
Spacer Plate Retaining Bolts	10	89	
Inside Detent Lever Nut	48		35
Oil Pump To Case Bolts	25		18
Center Support Bolt	11	100	
Valve Body Bolts	10	89	
Valve Body Cover Bolts	10	89	
Solenoid Body Bolts	8	71	
Reverse Servo Bolts	10	89	
Filter Bolts	10	89	
Bottom Pan Bolts	11	100	
Extension Housing Bolts	39		29
Output Flange Retaining Nut	131		97
Transmission Range Sensor	10	89	
Outer Manual Shift Lever Nut	48		35
Speed Sensors	10	89	

Figure 190

FORD 5R55N VERSUS 5R55W TRANSMISSION DIFFERENCES

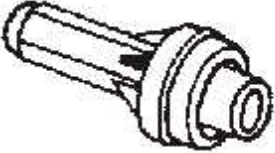
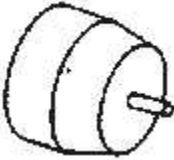
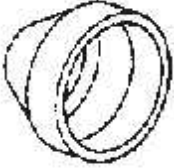
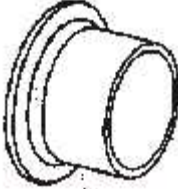
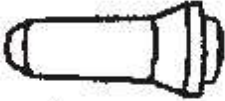
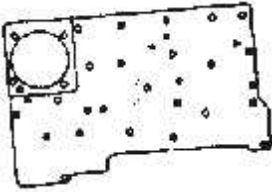
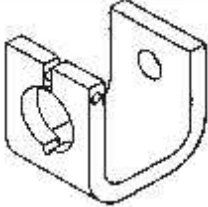
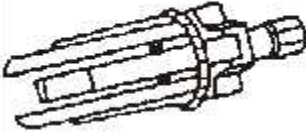
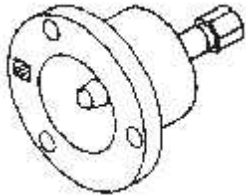
The Ford Motor Company's 5R55N (Non Sync.) transmission first appeared in the 2000 Lincoln "LS" and some of the Jaguar Models, which we are already somewhat familiar with. Beginning at the start of production for model year 2002, Ford has introduced the 5R55W (Wide Ratio) transmission into the some 4WD models of the Ranger and Explorer, and the 5R55S (Sync) transmission into some of the 2WD Ranger/Explorer and the 2004 Thunderbird. The internal parts look almost identical, but will not interchange with their look-alikes in the 5R55N transmission. The information in this bulletin will help you in getting the proper replacement parts back into the proper unit. Externally these transmissions are easy to identify and we have provided illustrations of both transmissions in Figure 191.

Figure 192 is an illustration of the two different turbine shafts. They are identical in every respect except for the overall length.

Figures 193 and 194 show you the differences in the overdrive sun gear and drive plate. Notice the differences in the tooth count on the sun gear.

Figures 195 and 196 are illustrations of the two different coast clutch housings. Notice that the slots to accept the tabs on the adapter plate are narrower and angled to the left at a very slight angle. This means that it will engage into the coast clutch housing in only one direction.

Continued on next Page 109

Copyright © 2004 ATSG



Technical Service Information

Figure 197 illustrates the internal components of the forward clutch housing for the 5R55N. Figure 198 illustrates the internal components of the forward clutch housing for the 5R55W/S. The only difference in the empty forward clutch housings is the chamfer in the 5R55W/S is wider.

Figure 199 is illustrations of the two different, completed forward clutch housing assemblies. Notice that the only visible difference is the piston and the return spring retainer.

Figure 200 and 201 are illustrations of the two different forward planetary carriers and the two different forward planetary internal ring gears. Notice the different tooth count on the planetary carrier pinions and the different tooth counts on the forward internal ring gear.

Figure 202 and 203 are illustrations of the two different sun gear and shell assemblies. Notice that the 5R55N uses an intermediate sprag and the 5R55W/S does not. This required a taller spacer as shown in Figure 203. Notice also the difference in tooth count of the forward sun gear, but the rear sun gear remains the same.

Figure 204 shows 3 dimensional illustrations of the two different valve body assemblies. The most noticeable difference is the 5R55W/S does not use a cover plate. The bolt pattern however, is exactly the same as the 5R55N transmission.

Figure 205 shows illustrations of the two different valve body assemblies in the worm track area, different amount of checkballs and the locations, and the retainer locations for both valve bodies.

Figure 206 is illustrations of the two different valve body spacer plates. One hole location for the spacer plate retaining bolts has changed to help prevent you from a mis-match.

Figure 207 and 208 are illustrations of the two different reverse servo housings. Notice that the 5R55W/S transmission has two feed holes in the housing, has a larger diameter for the inner piston seal, and has a different reverse servo check valve.

Figure 209 is illustrations of the two different reverse servo return springs. Notice the difference in the spring dimensions.

Figure 210 is illustrations of the two different of the two different reverse servo pistons. Notice the difference in the outside diameter of the body, to accommodate the larger diameter in the housing.

Figures 211 and 212 are illustrations of the two different intermediate servo covers and the intermediate servo pistons.

CAUTION:

**NONE OF THE COMPONENTS LISTED ABOVE WILL
INTERCHANGE BETWEEN THESE TWO SIMILAR TRANSMISSIONS**

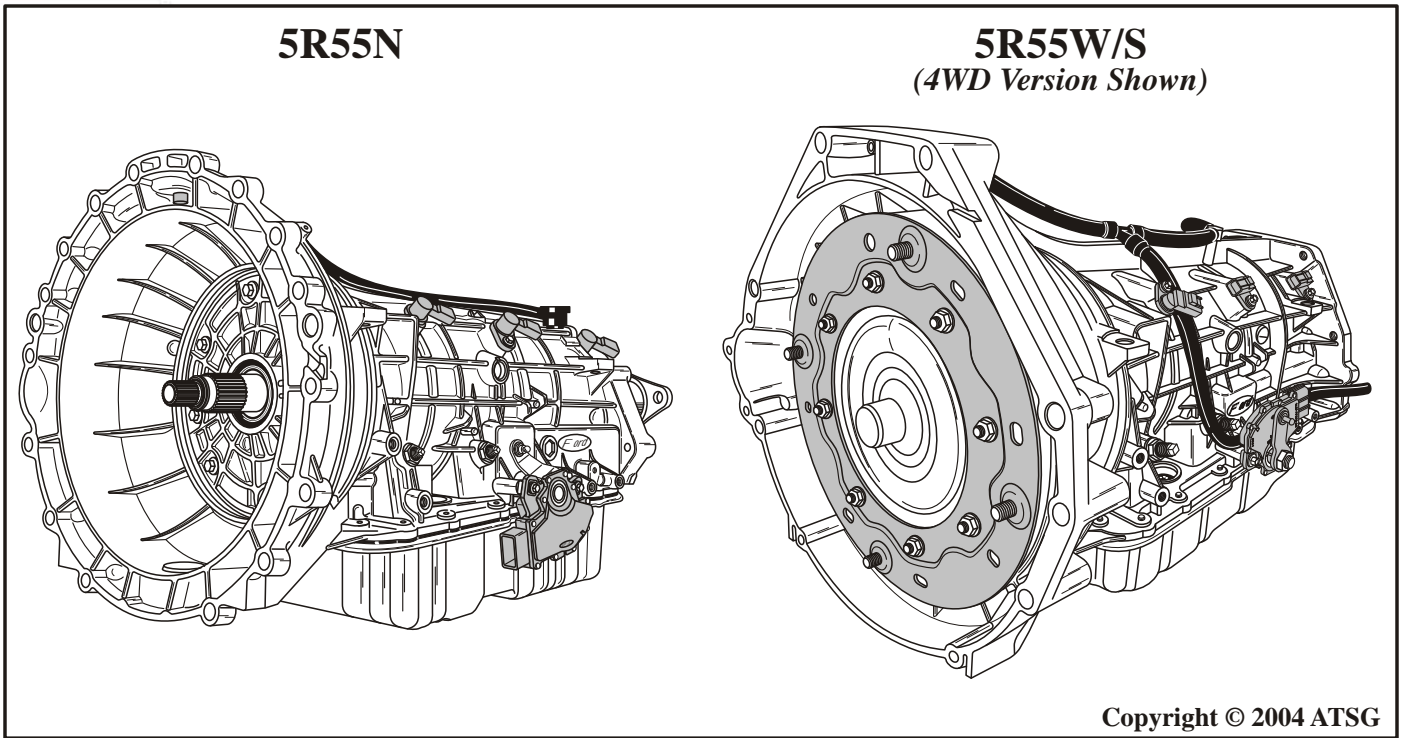

Figure 191

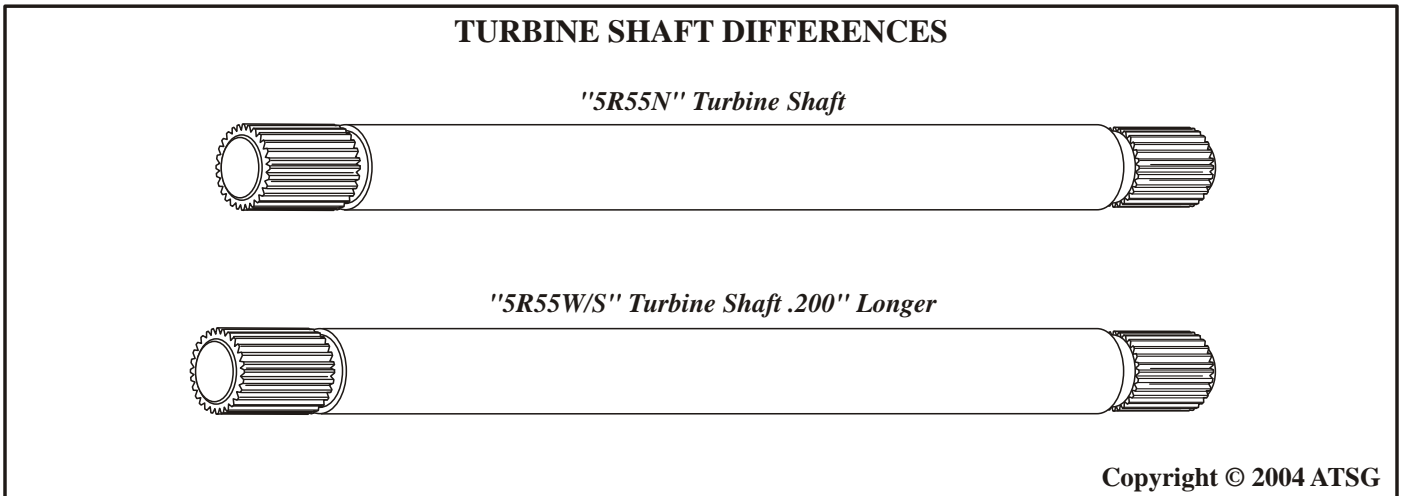

Figure 192

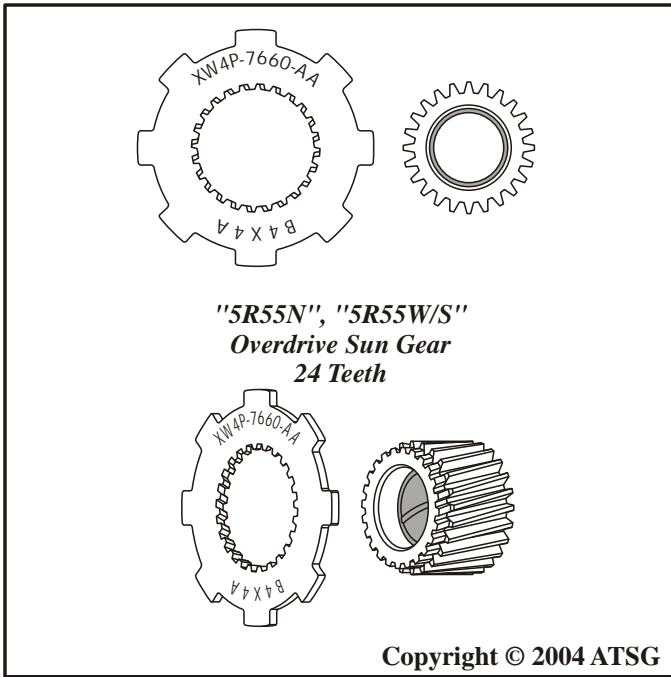

Figure 193

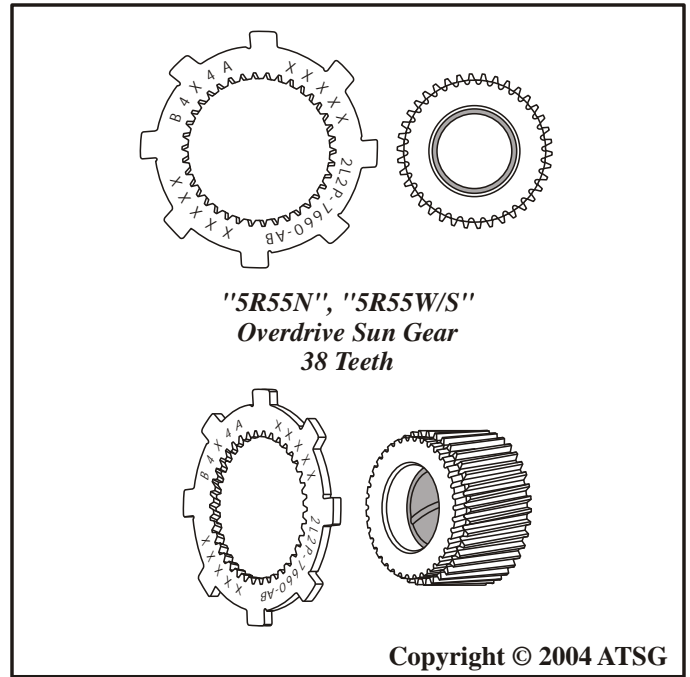

Figure 194

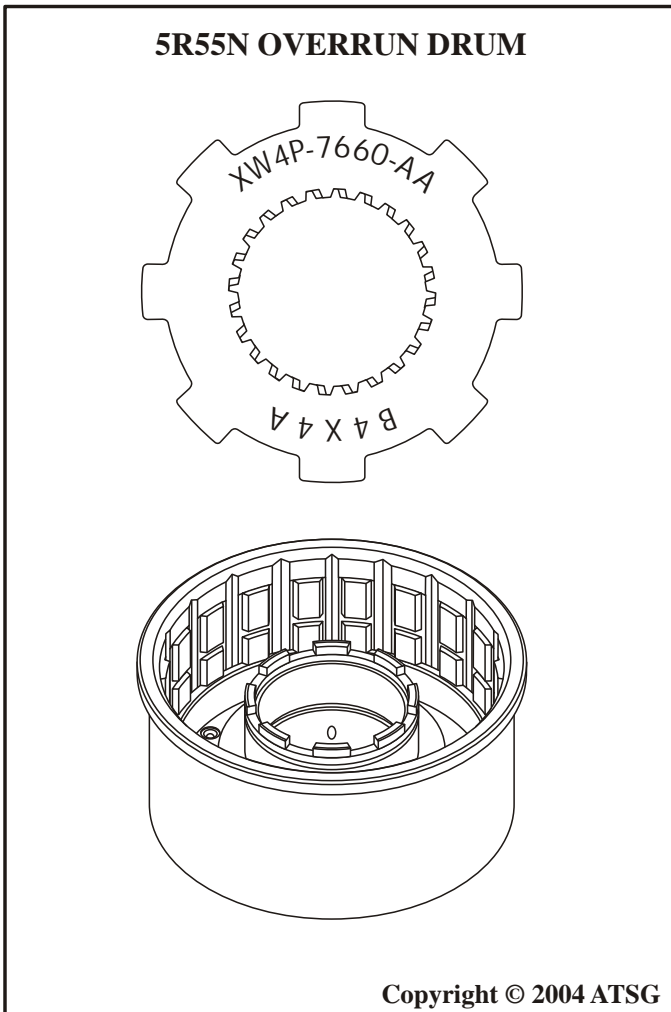

Figure 195

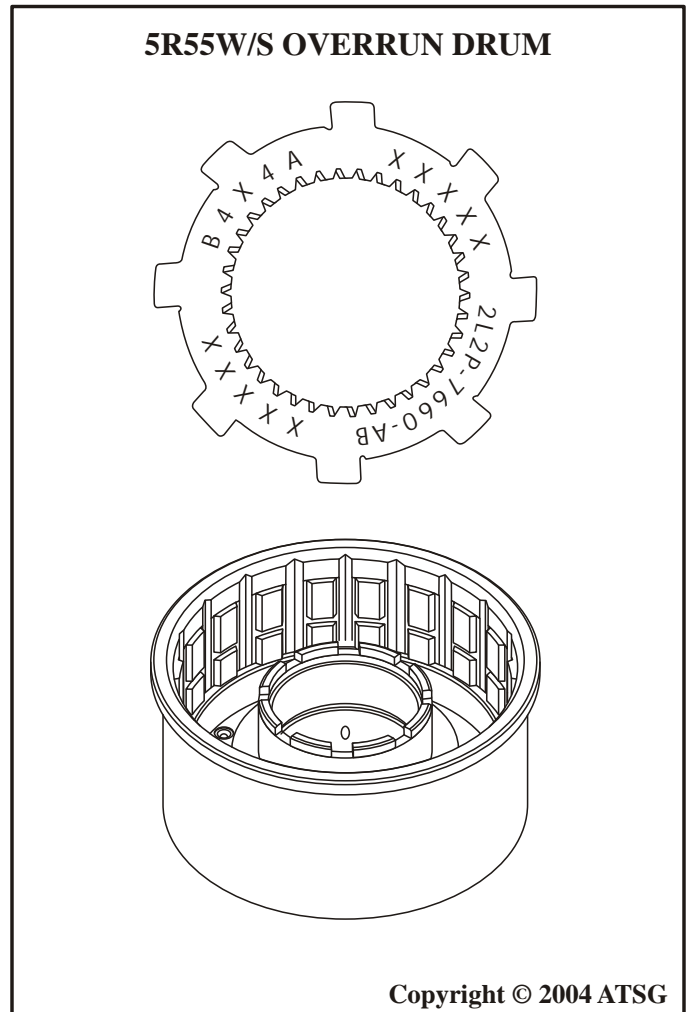

Figure 196

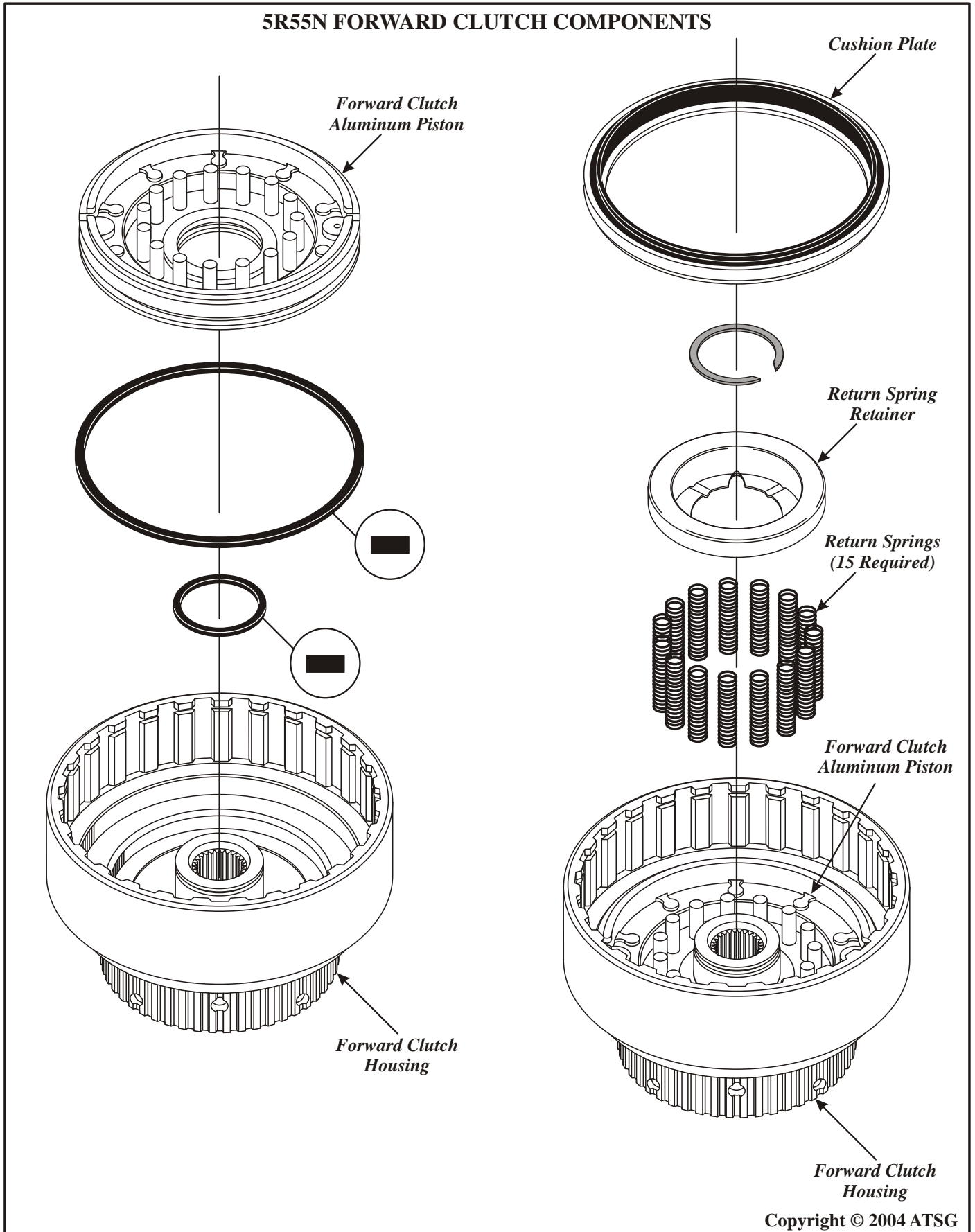

Figure 197

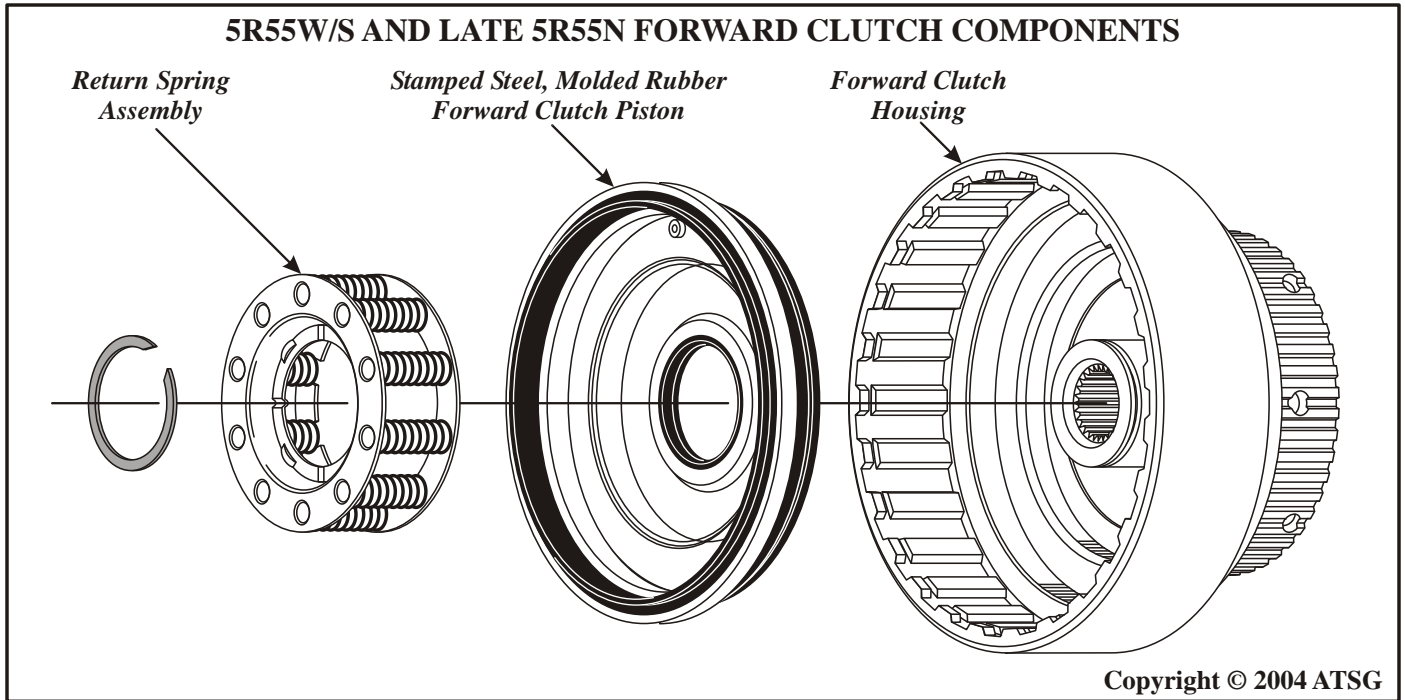

Figure 198

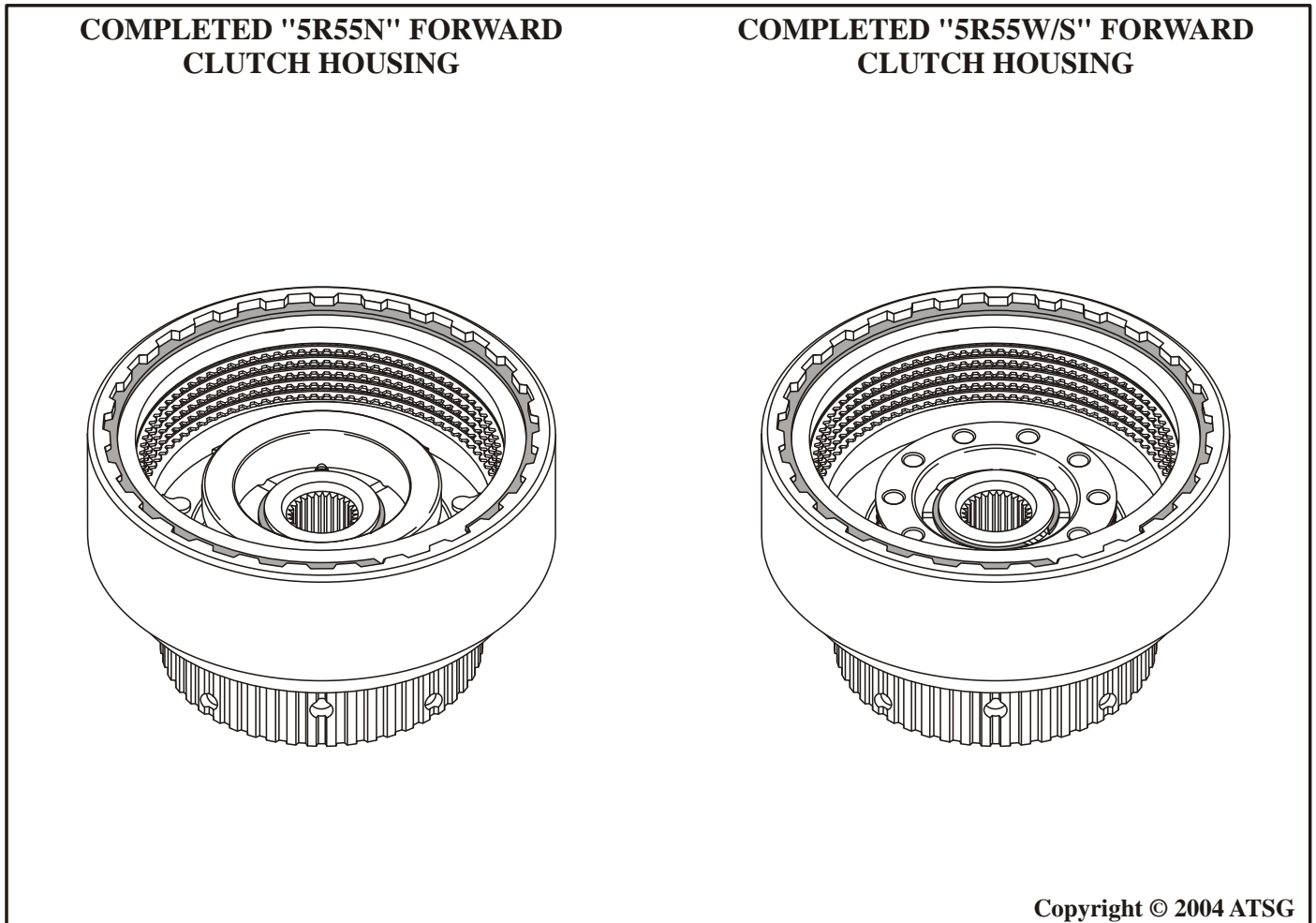

Figure 199

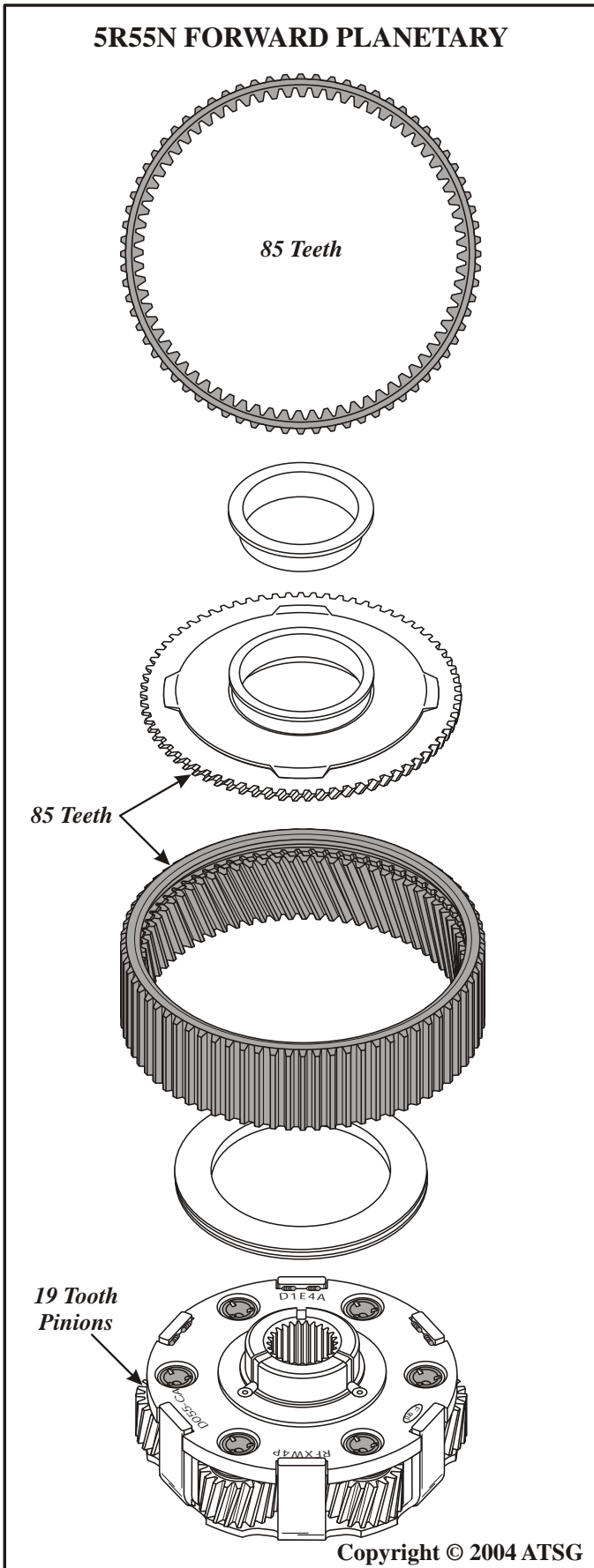

Figure 200

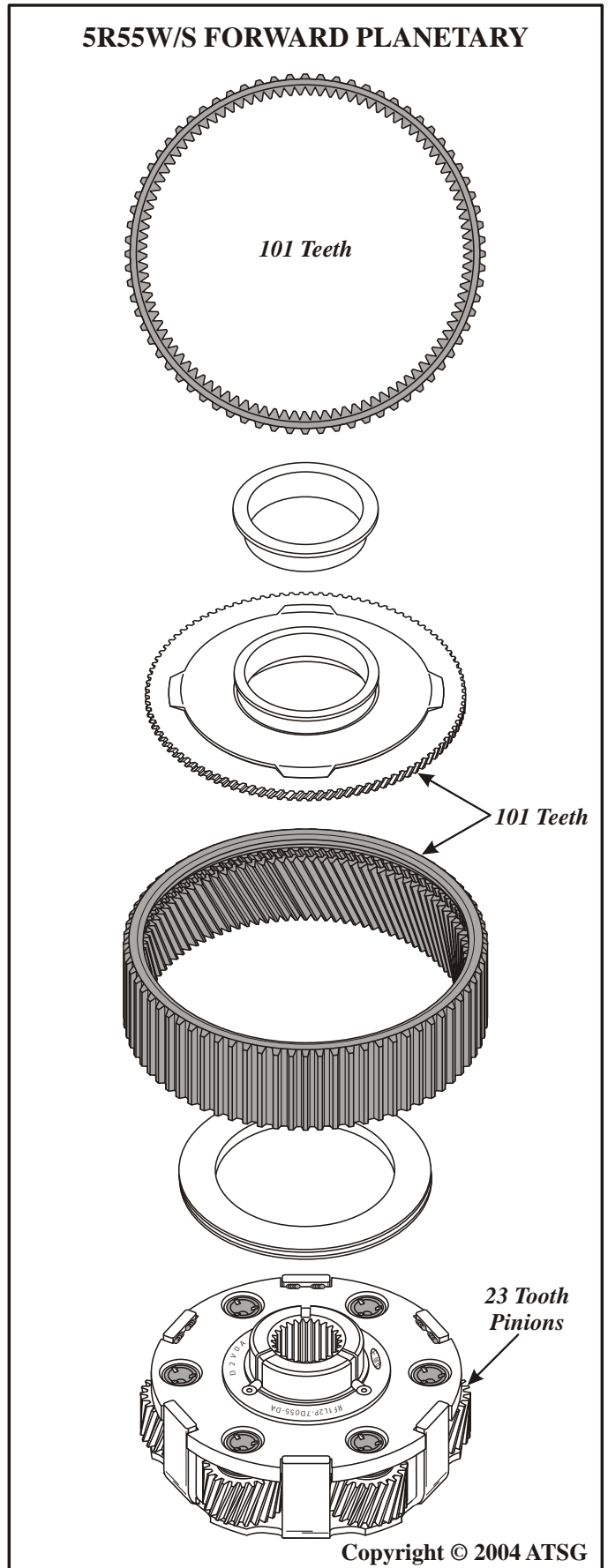

Figure 201

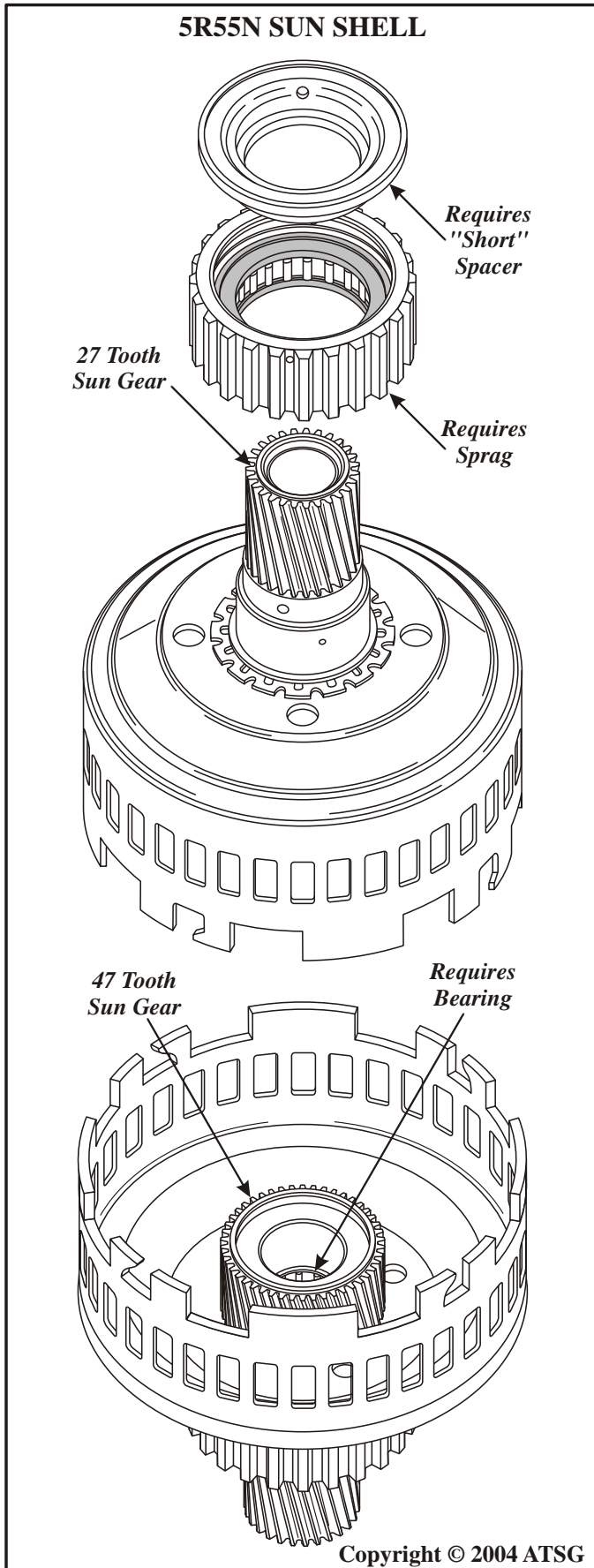

Figure 202

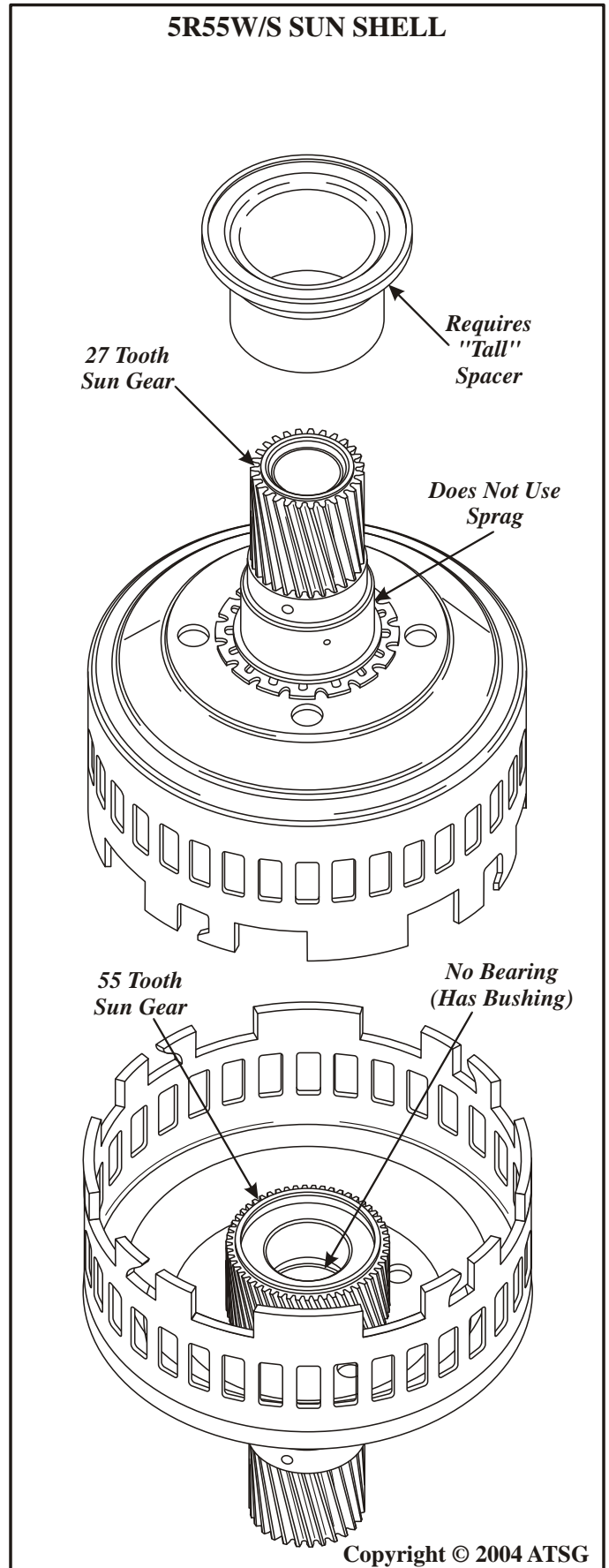

Figure 203

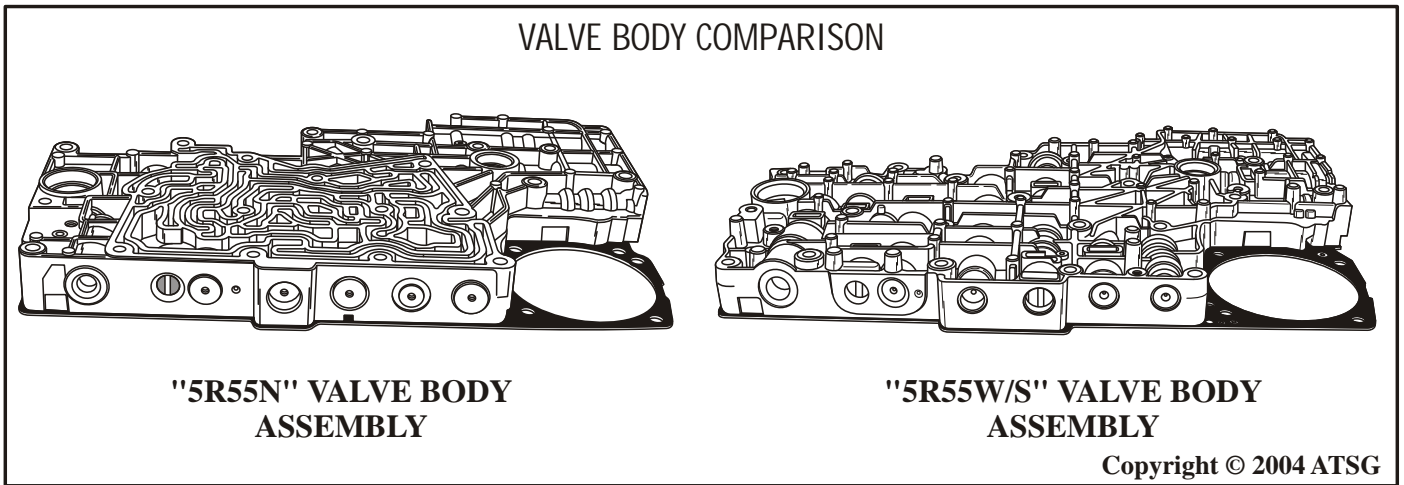

Figure 204

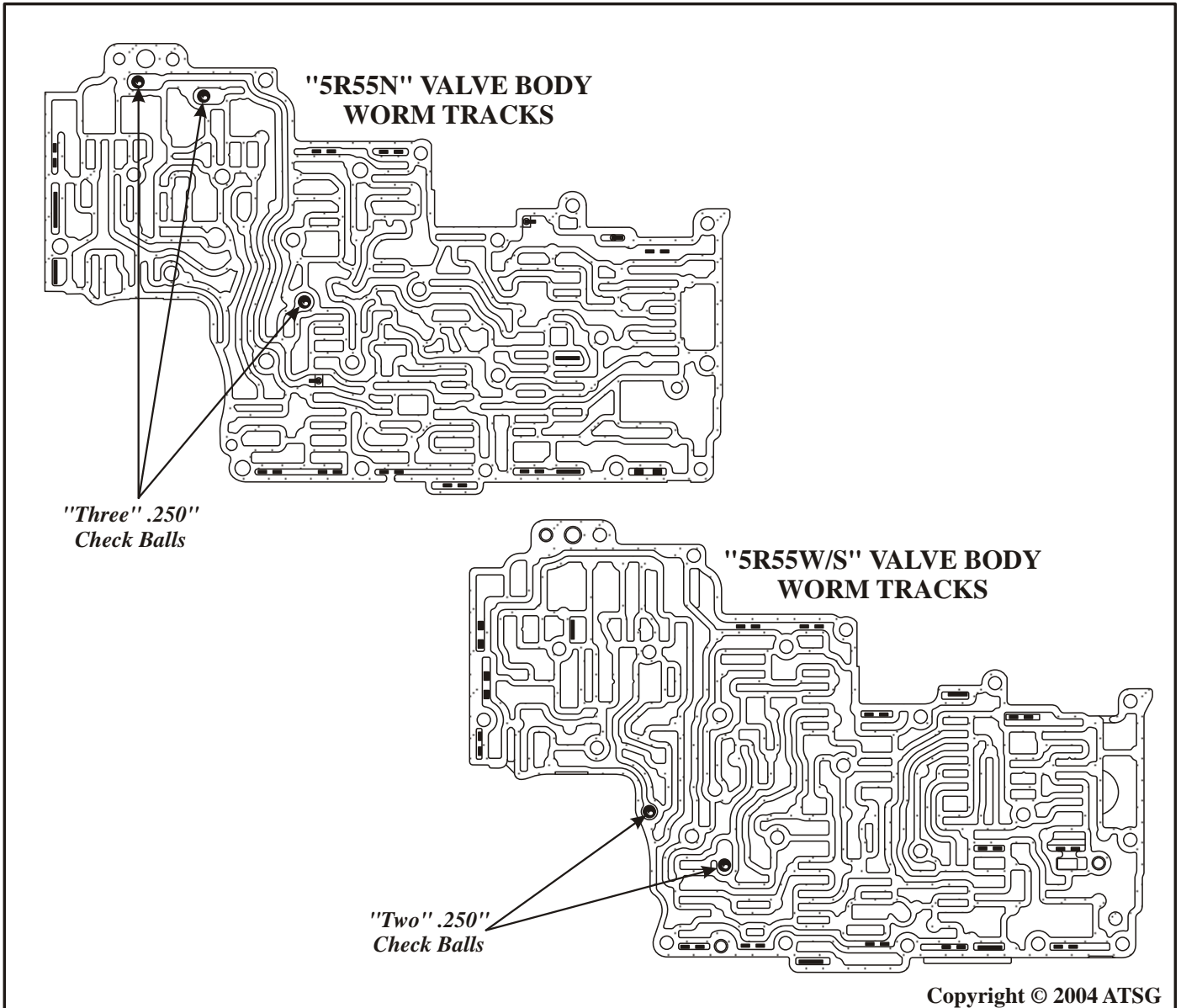
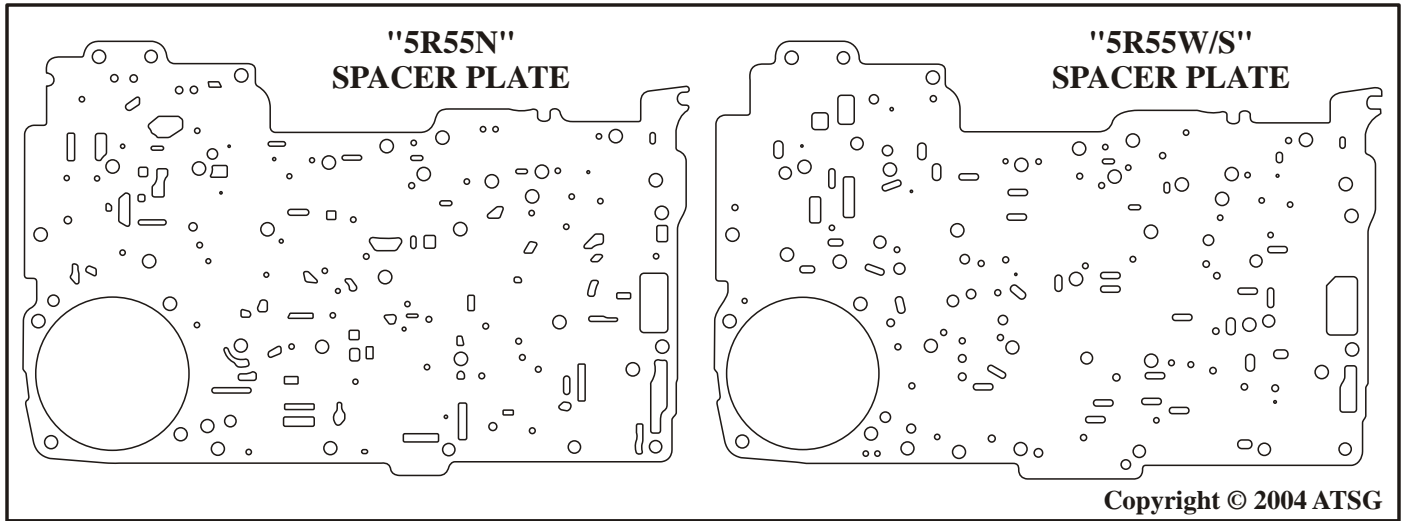
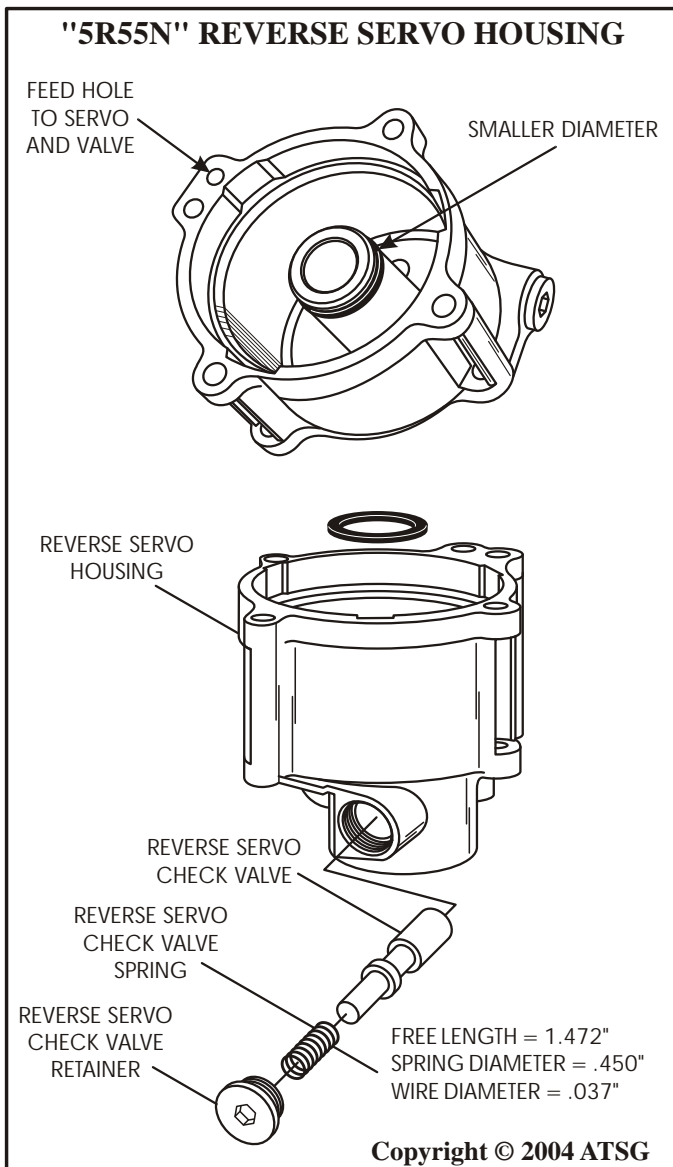

Figure 205



Copyright © 2004 ATSG

Figure 206



Copyright © 2004 ATSG

Figure 207

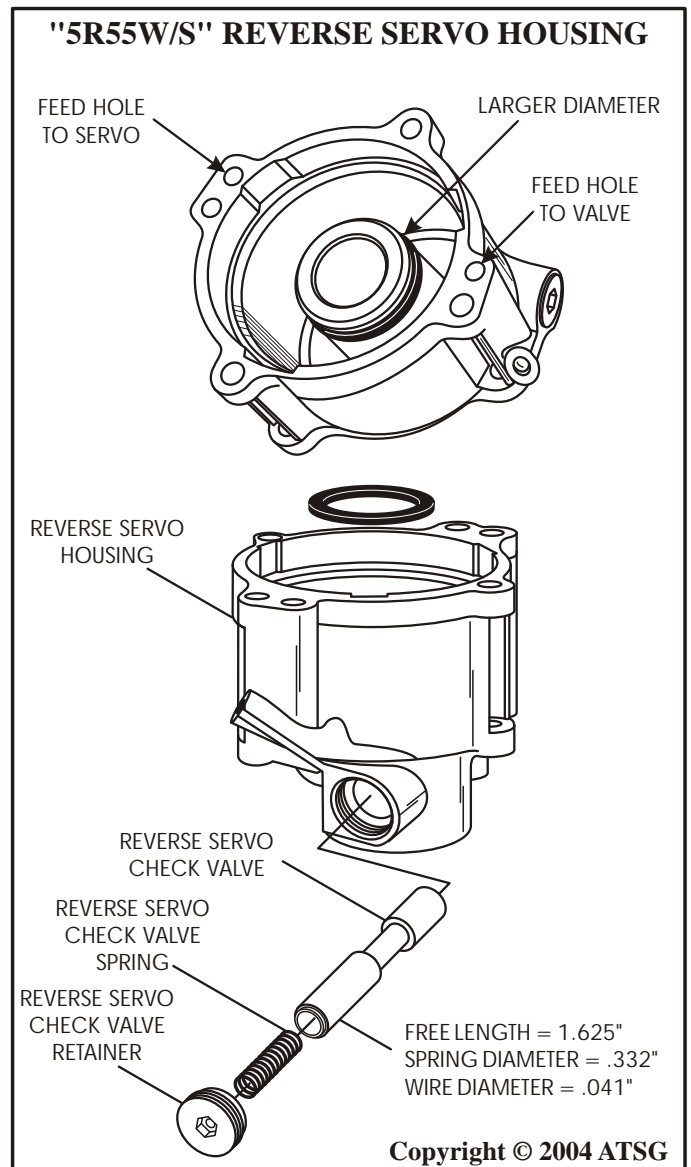

Copyright © 2004 ATSG

Figure 208

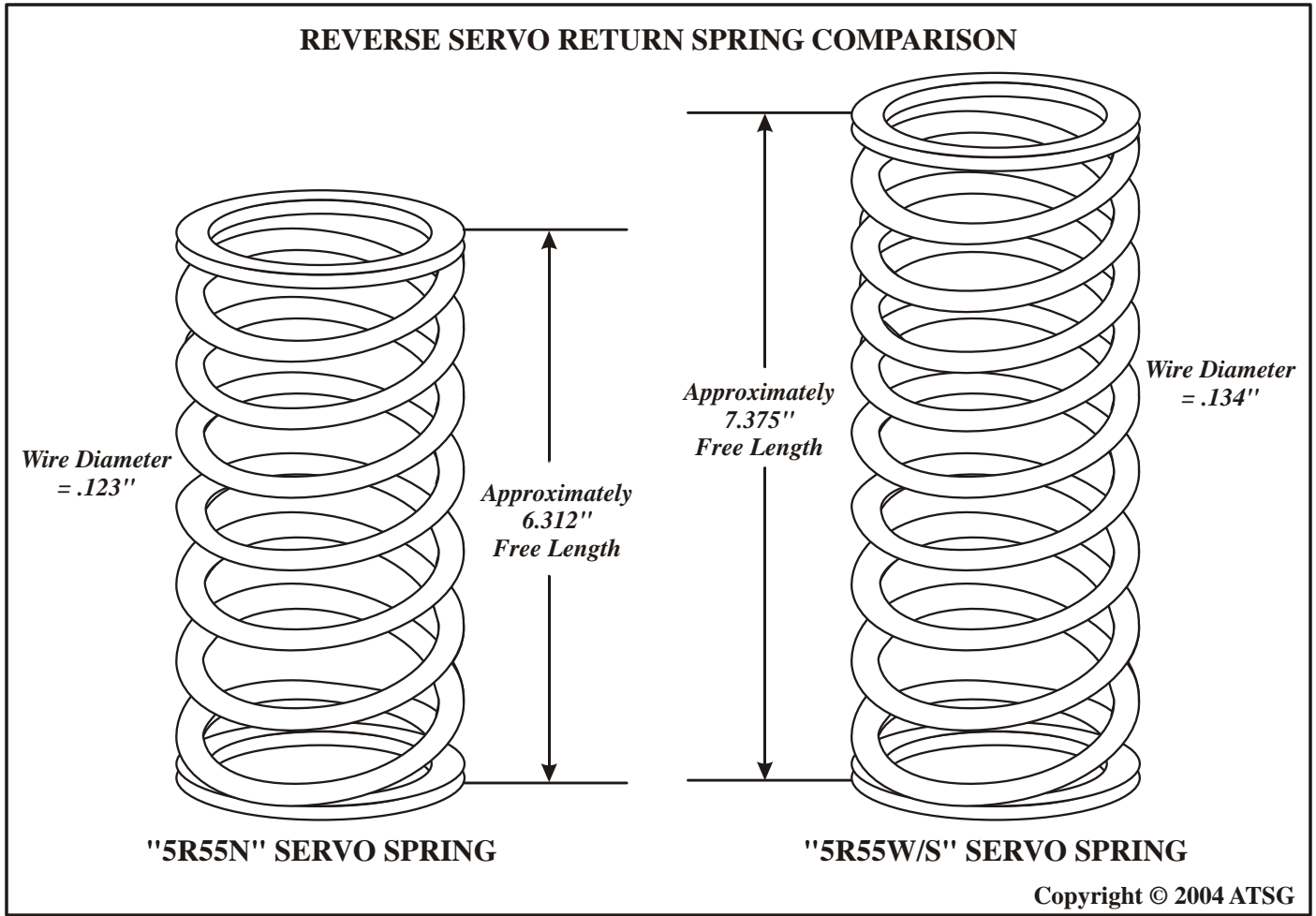

Figure 209

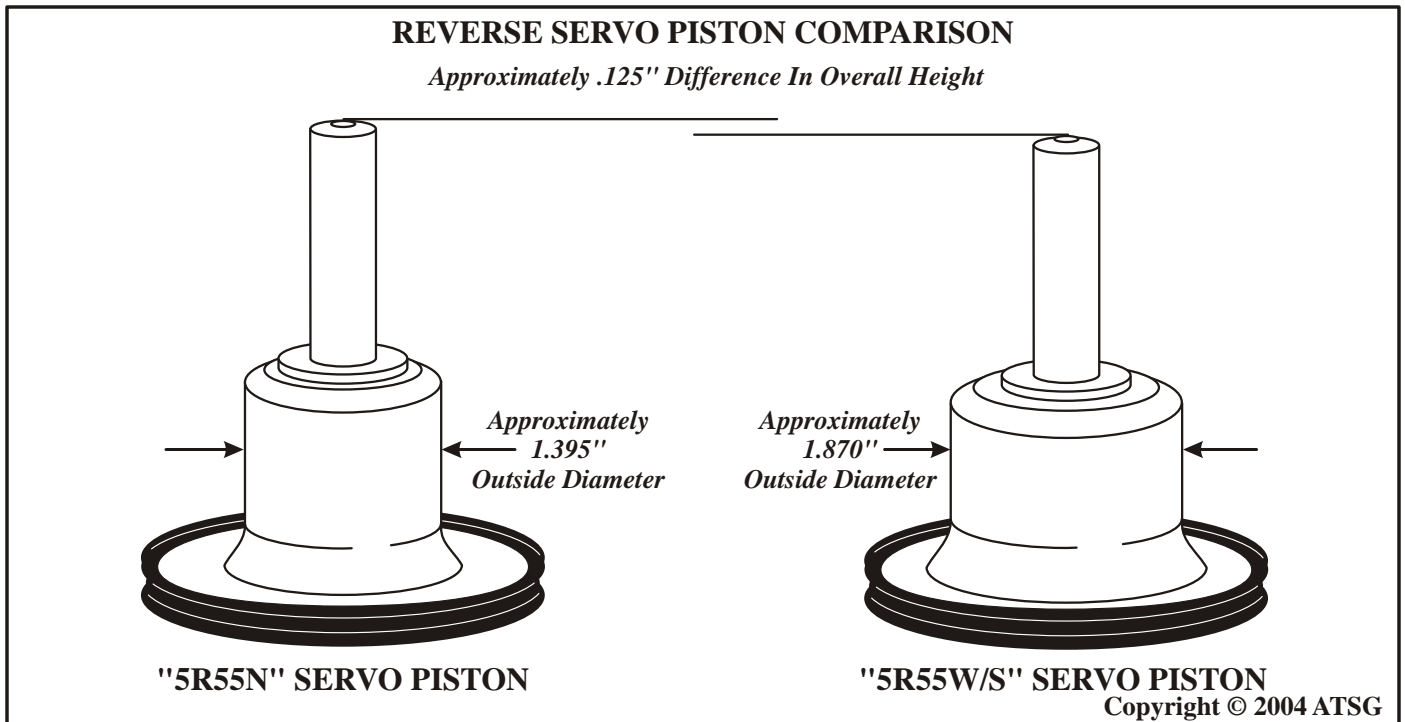

Figure 210

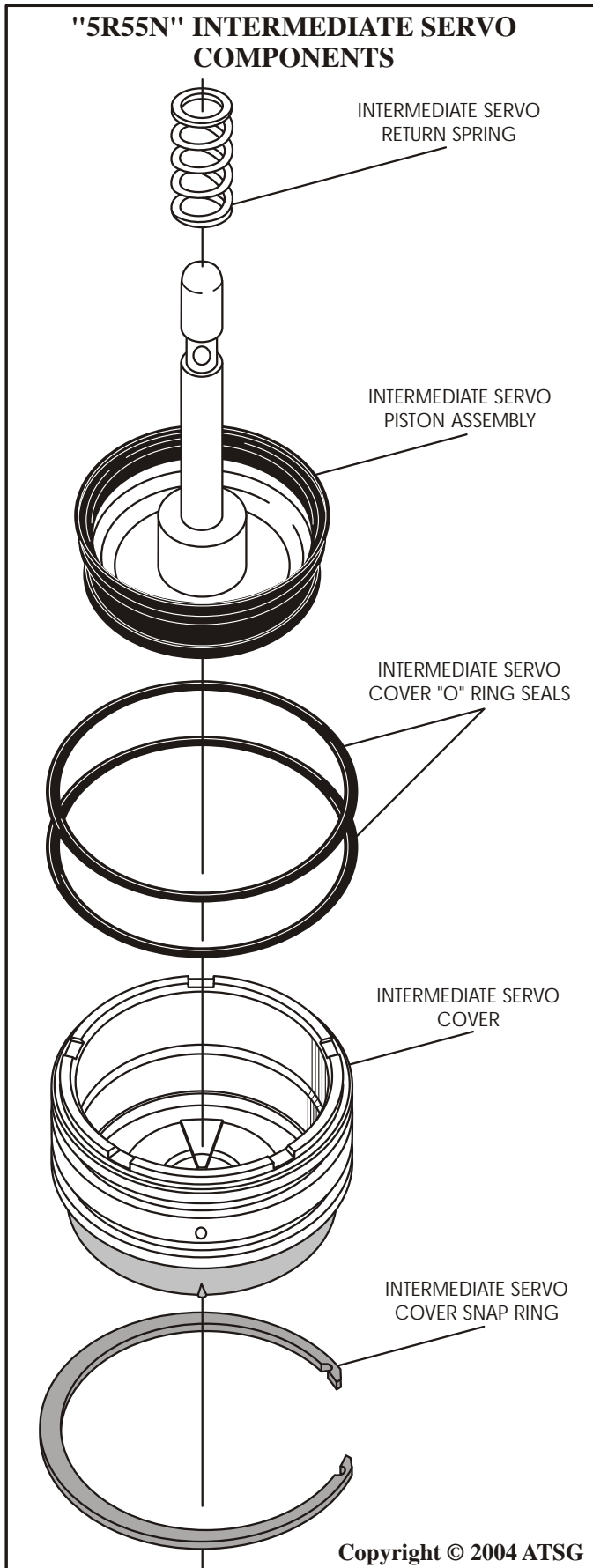

Figure 211

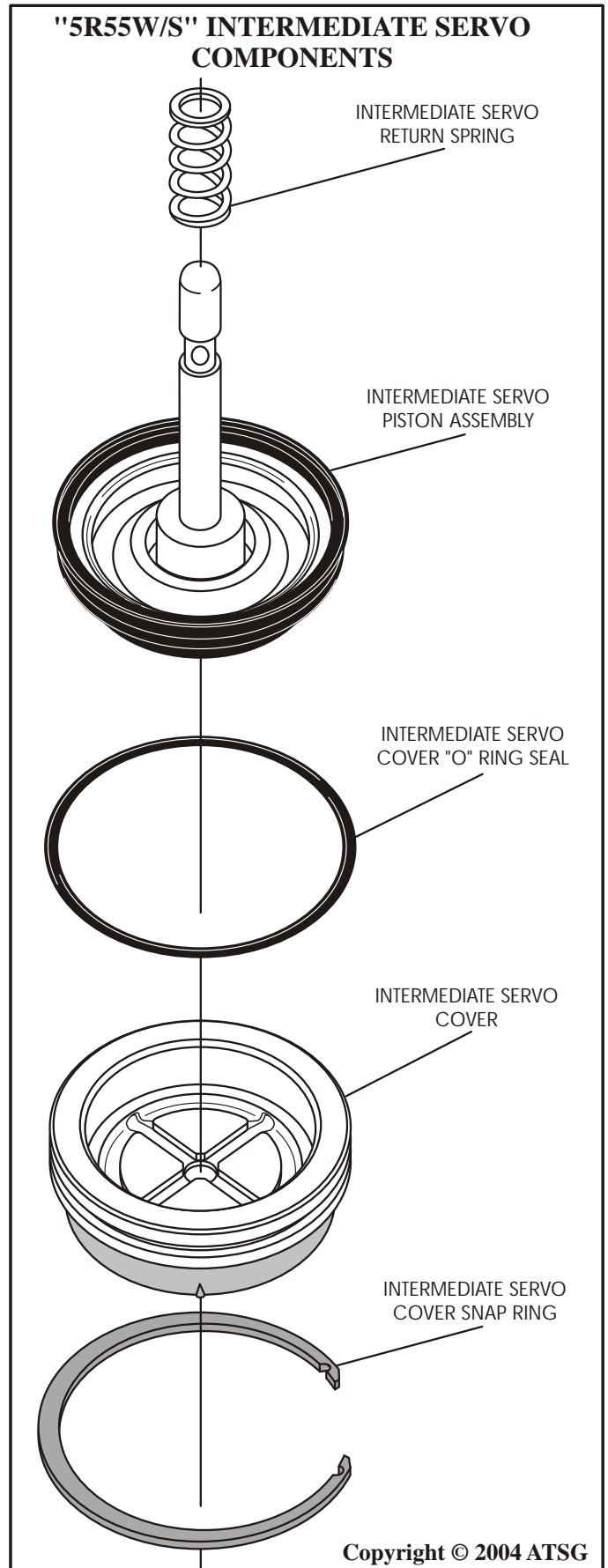

Figure 212



Technical Service Information

Notes